



Installation Manual

Cummins **Onan**

Performance you rely on.™



Hybrid Quiet Diesel Power System HQDSA

Power Unit HQDPC
Inverter Charger HQDVA
Transfer Switch HQDTA

California

Proposition 65 Warning

Diesel engine exhaust and some of its constituents are known to the State of California to cause cancer, birth defects, and other reproductive harm.



WARNING



**Do not use this genset on a boat
Such use may violate U. S. Coast Guard
regulations and can result in
severe personal injury or death from
fire, electrocution, or
carbon monoxide poisoning**

Table of Contents

SAFETY PRECAUTIONS	iv
1. INTRODUCTION	1-1
About this Manual	1-1
About The Hybrid Power System	1-1
Installation Codes and Standards for Safety	1-2
2. POWER UNIT INSTALLATION	2-1
Outline Drawing	2-1
Mounting	2-1
Location	2-2
Enclosure	2-3
Cooling and Ventilation	2-3
Exhaust Connections	2-4
Fuel Connections	2-7
Coolant Connections	2-7
Communications Connections	2-7
Battery Connections	2-7
AC Output Connections	2-7
3. INVERTER/CHARGER INSTALLATION	3-1
Location, Mounting and Enclosure	3-1
Coolant Connections	3-3
Electrical Connections	3-3
4. TRANSFER SWITCH INSTALLATION	4-1
Mounting	4-1
Electrical Connections	4-1
5. ACCESSORY KIT INSTALLATIONS	5-1
Shunt/Fuse Block	5-1
Operator Panel	5-1
6. AC CONNECTIONS	6-1
General	6-1
AC Wire Strip Lengths and Terminal Torques	6-2
Shore Power Fuses	6-3
Shore Pass-Through Circuits	6-3

Connections at Transfer Switch	6-3
Connections at Inverter/Charger	6-5
Connections at Power Unit	6-6
7. COMMUNICATIONS AND INPUT CABLES	7-1
General	7-1
Power Unit Connections	7-2
Load Demand Input	7-3
Auto Safety Input	7-3
Battery Saver Signal	7-4
Shunt Input	7-5
Battery Temperature Sensor	7-6
8. COACH BATTERY INSTALLATION	8-1
General	8-1
Battery Type	8-1
Battery Enclosure	8-1
Battery Voltage	8-1
Battery Capacity	8-1
Connections to Coach Batteries	8-1
9. COACH BATTERY CONNECTIONS	9-1
General	9-1
Inverter/Charger Connections	9-2
Power Unit Connections	9-4
DC Load Connections and Disconnect Switch	9-6
10. INSTALLATION REVIEW AND STARTUP	10-1
Installation Review	10-1
Startup	10-3
APPENDIX A. OPERATOR PANEL	A-1
About the Operator Panel	A-1
Home Screen	A-2
AUTO Button	A-3
Clock Button	A-6
Manual Button	A-7
Status Menu	A-8
Batt Status	A-9
Auto Status	A-10
Gen Status	A-11

Inv Status	A-12
Shore Status	A-13
Fault Information	A-14
Setup Menu	A-15
Auto Setup	A-16
Shore Breaker	A-17
Screen Setup	A-18
Service Menu	A-19
Input Setup	A-20
Battery Setup	A-21
Equalize	A-22
About	A-24
Warning and Prompt Screens	A-25
APPENDIX B. BATTERY INTERCONNECTIONS	B-1
APPENDIX C. HOT AIR RECIRCULATION TEST	C-1
APPENDIX D. SPECIFICATIONS	D-1
APPENDIX E. OUTLINE AND SYSTEM DRAWINGS	E-1



SAFETY PRECAUTIONS

Thoroughly read the OPERATOR'S MANUAL before operating the Hybrid Quiet Diesel Power System (Hybrid Power System). Safe operation and top performance can only be obtained when equipment is properly operated and maintained.

The following symbols in this manual alert you to potential hazards to the operator, service person and equipment.

⚠ DANGER alerts you to an immediate hazard that will result in severe personal injury or death.

⚠ WARNING alerts you to a hazard or unsafe practice that can result in severe personal injury or death.

⚠ CAUTION alerts you to a hazard or unsafe practice that can result in personal injury or equipment damage.

For quick reference the potential hazards of this type of equipment and the precautions to take are listed below in this section.

GENERAL PRECAUTIONS

- Keep children away from Hybrid Power System components.
- Do not use evaporative starting fluids. They are highly explosive.
- Let the engine cool down before removing the coolant pressure cap or opening the coolant drain. Releasing hot coolant under pressure can lead to severe burns.

- Keep the Hybrid Power System components and their enclosures clean. Oil collects dirt that can restrict cooling. Oily rags can catch fire. Stowed gear can block cooling air.
- Make sure all fasteners are secure and torqued properly.
- Do not perform Hybrid Power System maintenance or service when mentally or physically tired or after consuming alcohol or drugs.
- You must be trained and experienced to make adjustments while the Hybrid Power System is in operation—hot, moving or electrically live parts can cause severe personal injury or death.
- Used engine oil has been identified by some U. S. state and federal agencies as causing cancer or reproductive toxicity. Do not ingest, inhale, or contact used oil or its vapors.
- Ethylene glycol, used as engine antifreeze, is toxic to humans and animals. Clean up spills and dispose of used engine coolant in accordance with local environmental regulations.
- Keep a multi-class ABC fire extinguisher in the vehicle. Class A fires involve ordinary combustible materials such as wood and cloth. Class B fires involve combustible and flammable liquids and gaseous fuels. Class C fires involve live electrical equipment. (ref. NFPA No. 10)
- The Hybrid Power System installation must comply with all applicable local, state and federal codes and regulations.



ENGINE EXHAUST IS DEADLY

Engine exhaust gases include CARBON MON-OXIDE (CO), an odorless, colorless, poisonous gas that can cause severe personal injury or death. Symptoms of CO poisoning include:

- Dizziness, Headache or Throbbing Temples
- Weakness or Muscular Twitching
- Sleepiness or Confusion
- Nausea or Vomiting

If you or anyone else experiences any of these symptoms, get out into fresh air immediately. Get advice from 911, poison control or a medical center. Do not enable AUTO or start Generator Mode until the exhaust system has been repaired.

To reduce the risk of CO poisoning from engine exhaust:

- Check for exhaust leaks every day and after every eight hours of operation.
- Do not enable AUTO or start Generator Mode before going to sleep unless the coach has working CO detectors.
- Disable AUTO and stop Generator Mode when parking the coach in a garage or other confined space.
- Do not use engine cooling air to heat the coach. It may contain exhaust gases.
- The exhaust system must be installed in accordance with the Hybrid Power System Installation Manual.

POWER SYSTEM VOLTAGES ARE DEADLY

- Before servicing the coach or Hybrid Power System, disconnect Shore Power, push the Power Unit circuit breaker OFF and turn the Coach DC Disconnect Switch to Disconnect (to power down the Hybrid Power System).

- Electrical connections must be made by a trained and experienced electrician in accordance with the Hybrid Power System Installation Manual and applicable codes.
- Do not connect the Power Unit to the Coach AC circuits. Its high output voltages can damage equipment and cause death or severe personal injury.
- Improper transfer of loads between the Hybrid Power System and Shore Power can lead to electrocution of utility line workers and damage to equipment. Connections must be made by a trained and experienced electrician in accordance with the Hybrid Power System Installation Manual and applicable codes.
- Use caution when working on live electrical equipment. Remove jewelry, make sure clothing and shoes are dry, stand on a dry wooden platform or rubber insulating mat and use tools with insulated handles.
- Upon completing service, secure housing panels and covers to protect from electrical parts.

MOVING PARTS CAN CAUSE SEVERE PERSONAL INJURY OR DEATH

- Disconnect the 10-Pin and 4-Pin remote control connectors and battery cables from the Power Unit to prevent unintended starting while servicing. Insulate the end of the positive (+) battery cable to keep it from touching chassis ground.
- Keep hands away from fans, belts, pulleys and other moving parts.
- Remove loose clothing and jewelry.
- Upon completing service, secure housing panels and covers to protect from moving parts.



BATTERY GAS IS EXPLOSIVE

- Before servicing the batteries, disconnect Shore Power, push the Power Unit circuit breaker OFF and turn the Coach DC Disconnect Switch to Disconnect (to power down the Hybrid Power System).
- Wear safety glasses.
- Do not smoke.
- Remove jewelry.
- Observe proper battery cable connect/disconnect sequences.
- Secure DC terminal protective covers to prevent accidental shorting with metal tools.

IMPROPER CHARGING CAN OVERHEAT COACH BATTERIES AND CAUSE FIRE

Do not mix old and new batteries or different types of batteries. Reconfigure the Hybrid Power System for proper charging if battery type and bank capacity have changed.

DIESEL FUEL IS COMBUSTIBLE

- Do not smoke or turn electrical switches ON or OFF where fuel fumes are present or in areas sharing ventilation with fuel tanks or

equipment. Keep flames, sparks, pilot lights, arc-producing equipment and all other sources of ignition well away.

- Fuel lines must be secured, free of leaks and separated or shielded from electrical wiring.

COACH ELECTRICAL SYSTEMS CAN IGNITE FLAMMABLE VAPORS

- Disable AUTO and stop Generator Mode before fueling the coach to reduce the risk of igniting flammable vapors.
- Do not store liquid or gaseous fuel containers in the same enclosures as the Inverter/Chargers, Transfer Switch, batteries or other spark-producing equipment.

FLAMMABLE VAPORS CAN CAUSE DIESEL ENGINES TO OVERSPEED

Do not operate the diesel-powered Hybrid Power System where there are or can be flammable vapors created by fuel spills, gas leaks, etc. Flammable vapors drawn into a diesel engine air intake system can cause the engine to overspeed, which can result in fire, explosion and equipment damage. The owners and operators of the Hybrid Power System are solely responsible for safe operation.



1. Introduction

ABOUT THIS MANUAL

⚠WARNING *Improper installation can result in severe personal injury, death and equipment damage. The installer must be qualified to perform the installation of electrical and mechanical equipment.*

This is the installation manual for the Model HQDSA Hybrid Quiet Diesel Power System (Hybrid Power System), comprising:

- Model HQDPC Power Unit
- Model HQDVA Inverter/Charger
- Model HQDTA Transfer Switch
- Accessory Kits

For specific information about the system and its components, see *Appendix D. Specifications*.

Note: The Hybrid Power System will not work without these components, nor with substitutes.

Proper installation is essential for top performance, safety and compliance. Read through this manual before starting the installation.

See the Operator's Manual for operation and maintenance instructions.

Note: Manuals are updated from time to time to reflect changes in the equipment and its specifications. See an authorized Cummins Onan representative for current manuals.

ABOUT THE HYBRID POWER SYSTEM

⚠WARNING *This power system is not for life support. It can stop without warning. Children, persons with physical or mental limitations, and pets could suffer personal injury or death. A personal attendant, redundant power or an alarm system must be used if operation is critical.*

The Hybrid Power System components are integrated with Shore Power and Coach Batteries to comprise a complete Coach AC power supply system. The Operator Panel is used to monitor, control and configure the integrated power supply system.

⚠CAUTION *Unauthorized modifications or replacement of fuel, exhaust, air intake or speed control system components that affect engine emissions are prohibited by law in the State of California.*



INSTALLATION CODES AND STANDARDS FOR SAFETY

The installer bears sole responsibility for the selection of appropriate equipment, for its proper installation and for obtaining approvals from the authorities (if any) having jurisdiction over the installation. The Hybrid Power System is suitable for installation in accordance with:

- NFPA No. 1192—Recreational Vehicles
- NFPA No. 70, Article 551—Recreational Vehicles and RV Parks
- ANSI/RVIA-12V—Standard for Low Voltage Systems in Conversion and Recreational Vehicles

Federal, State and local codes, such as the California Administrative Code—Title 25 (RV installation), could apply. Installation codes and recommendations can change from time to time and are different in different countries, states and municipalities. It is recommended that the standards in Table 1-1 be obtained for reference.

TABLE 1-1. REFERENCE CODES AND STANDARDS

Code of Federal Regulations, Title 49: Chapter III and Chapter V	Superintendent of Documents P. O. Box 371954 Pittsburgh, PA 15250-7954
NFPA No 70, 1192	National Fire Protection Association 470 Atlantic Avenue Boston, MA 02210
ANSI/RVIA-12V	Recreational Vehicle Industry Association 14650 Lee Road Chantilly, VA 22021
California Administrative Code—Title 25, Chapter 3	State of California Documents Section P.O. Box 1015 North Highlands, CA 95660
CAN/CSA-Z240 Recreational Vehicles & CSA C22.1, Part 1 Canadian Electric Code	Canadian Standards Association Housing and Construction Materials Section 178 Rexdale Blvd. Rexdale, Ontario, Canada M9W 1R3
UL 1248, 458, 1008, 1004B	Underwriters Laboratories Inc 333 Pfingsten Road Northbrook, IL 60062

2. Power Unit Installation

OUTLINE DRAWING

Refer to the Power Unit Outline Drawing (p. E-3) for installation details: mounting bolt hole locations, connection points (fuel, battery, exhaust, coolant, remote control, AC output), sizes and types of fittings, cooling air openings, weight, service access points and overall dimensions. See your Onan dealer for a large-scale Outline Drawing and full-size floor cutout template.

MOUNTING

⚠WARNING *The Power Unit support structure must be designed and installed to support and restrain the dynamic weight of the Power Unit. Failure to do so can result in the Power Unit dropping onto the roadway causing property damage, severe personal injury and death.*

Supporting Structure

Support the Power Unit on a structure able to resist the dynamic weight of the Power Unit. Dynamic vertical weight (up and down) is defined as 3 times static weight and dynamic horizontal weight is defined as 1 times static weight. The power unit has a static weight of 391 lbs (177 kg). Vertical dynamic weight is therefore plus/minus 1173 lbs (531 kg) and horizontal dynamic weight is 391 lbs (177 kg).

Mounting Hardware

The Power Unit is shipped with four 3/8-16 by 1-1/2 inch thread-forming screws to secure it to the supporting frame or floor. Torque the mounting screws to 31 lb-ft (42 N-m).



LOCATION

Typical Power Unit locations on a vehicle are illustrated in Figure 2-1.

1. Provide access to the control panel so that the Power Unit can be started with the control switch, the circuit breakers can be reset and coolant and oil can be added.
2. Provide access underneath the Power Unit to change the air, oil and fuel filters and drain oil and coolant. The oil and fuel filter access door must be able to swing wide open. See PERIODIC MAINTENANCE in the Operator's Manual.
3. Provide access for connecting and disconnecting fuel lines, battery cables, remote control wiring and AC wiring.
4. Make sure that frame cross members, exhaust tail pipes and other equipment do not cross underneath the oil drain plug or air intake and discharge openings or the oil and fuel filter access door.
5. Provide access for removing the two fuel pump mounting screws so that the Power Unit does not have to be removed to replace the fuel pump.
6. Make sure the Power Unit clears the ground by at least 12 inches (305 mm) to provide adequate ventilation and reduce the amount of dust pulled in by the cooling fan.
7. The Power Unit must be located so that the inlet to the Power Unit is protected from direct exposure to rain and road splash. Compliance with this protection requirement for road splash is assumed whenever no line of sight can be projected from the Coach tire's contact with the road into the inlet of the Power Unit. Consideration may also need to be given to splash from vehicles sharing the road with the Coach. It is generally preferable to mount the Power Unit in front of, rather than behind, the Coach tires.
8. Locate or shield the Power Unit such that condensate from air conditioners will not drip on it.

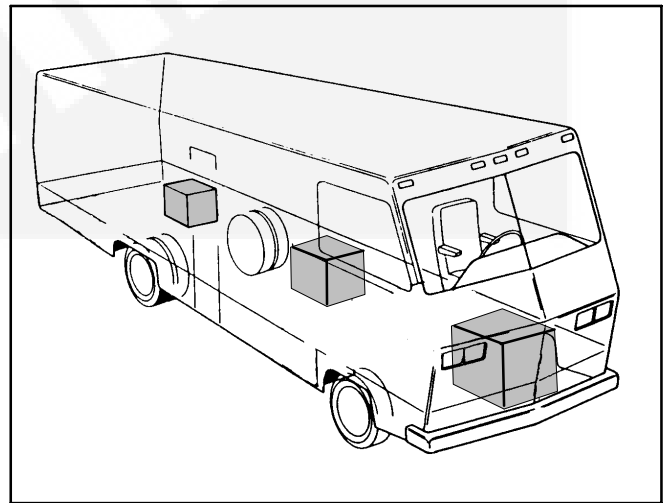

FIGURE 2-1. TYPICAL POWER UNIT LOCATIONS

ENCLOSURE

1. Provide a vapor and fire resistant barrier between the Power Unit and the interior of the vehicle. Use approved materials (26 gauge galvanized steel). See NFPA 1192 for details.

⚠WARNING **EXHAUST GAS IS DEADLY.** Construct a suitable vapor barrier of approved materials between the Power Unit and vehicle interior to keep out exhaust gas.

2. The enclosure must be large enough to provide at least 1/2 inch (12.7 mm) clearance at the top of the Power Unit and 1/4 inch (6.4 mm) clearance at the sides. These minimum clearances apply to the thermal or acoustic insulation with which the compartment may be lined. Minimum compartment dimensions are:
 - A. Height: 22.78 inches (578.6 mm)
 - B. Width: 24.73 inches (628.1 mm)
 - C. Length: 36.85 inches (936 mm)
3. Acoustic/thermal insulation and adhesive must be rated as "Self-Extinguishing." Do not line the

bottom of the compartment with insulation, which can absorb spilled fuel and oil.

COOLING AND VENTILATION

⚠WARNING **EXHAUST GAS IS DEADLY!** Do not duct air discharged from the Power Unit into the vehicle.

The air intake and discharge openings are in the bottom of the Power Unit (Figure 2-2). Unrestricted air flow for cooling, ventilation and combustion is essential for proper Power Unit performance and service life. Refer to *Appendix C. Hot Air Recirculation Test*.

If the Power Unit is installed on a floor, cut out openings in the floor that are at least as large as the openings in the Power Unit.

Make sure frame cross members, exhaust tail pipes and other equipment do not cross underneath the air intake and discharge openings. *Do not block the air inlet and outlet openings with screens, expanded metal or the like; they restrict air flow and could cause the Power Unit to overheat.*

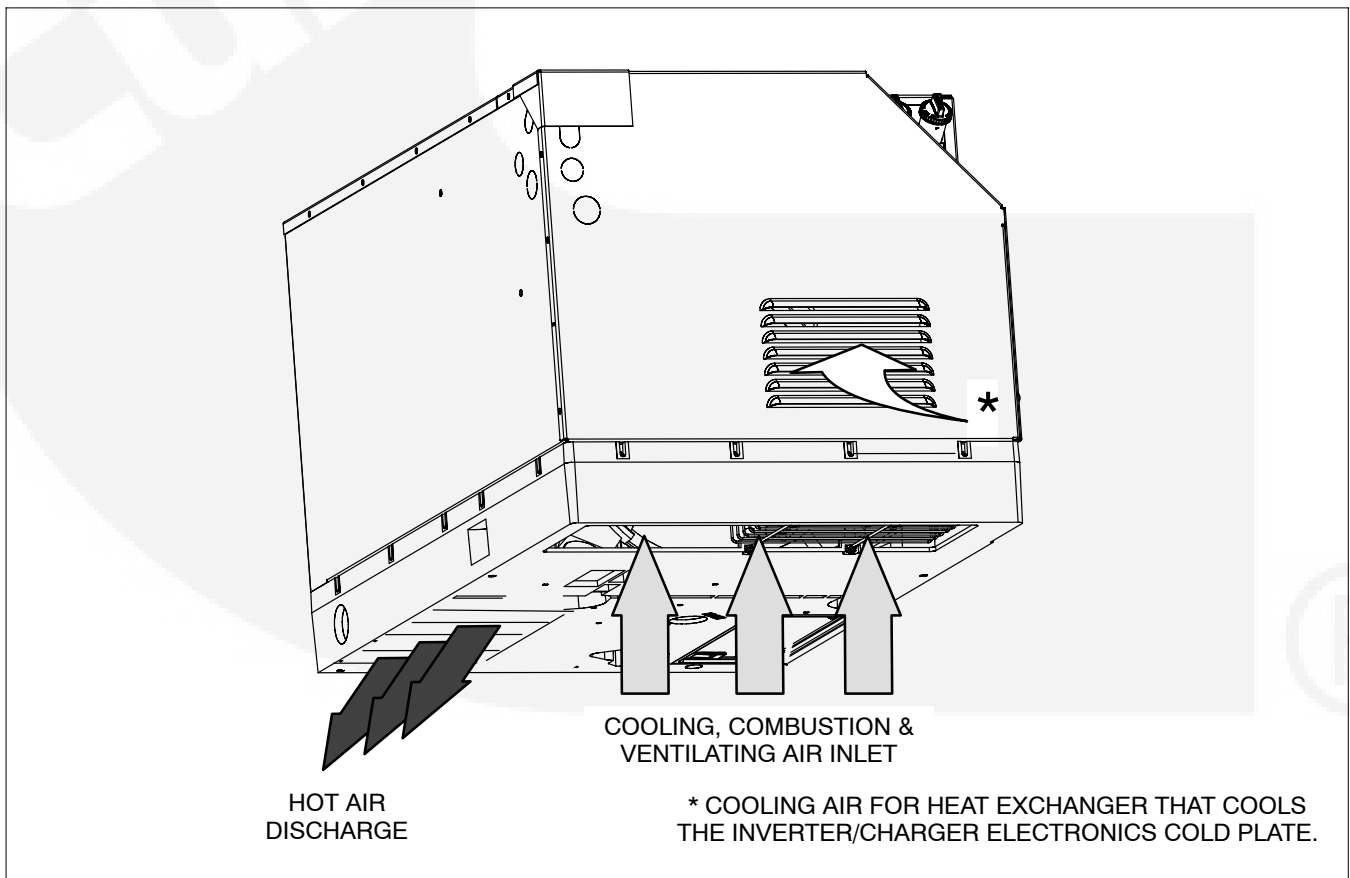

FIGURE 2-2. COOLING, VENTILATING AND COMBUSTION AIR FLOWS

EXHAUST CONNECTIONS

⚠ WARNING *EXHAUST GAS IS DEADLY! Keep exhaust gases from entering the vehicle. Do not terminate the exhaust tailpipe underneath the vehicle or closer than specified to openings into the vehicle or route it such that it is likely to be damaged. Use approved materials and parts only.*

⚠ CAUTION *Modifications or replacements of fuel, exhaust, air intake or speed control system components that affect engine emissions are prohibited by law in the State of California.*

Muffler

The muffler is mounted inside the Power Unit housing (Figure 2-3). It has been qualified as a USDA (Forest Service) spark arrester. See the Power Unit Outline Drawing for the exhaust outlet flange dimensions.

A Power Unit without a properly installed and maintained spark arresting exhaust system can cause a forest fire. It is illegal on federal lands. Liability for damage, injury and warranty expense due to the modification of the exhaust system or to the use of unapproved parts is the responsibility of the person performing the modification or installing the unapproved parts. Contact an Onan distributor for approved exhaust system parts.

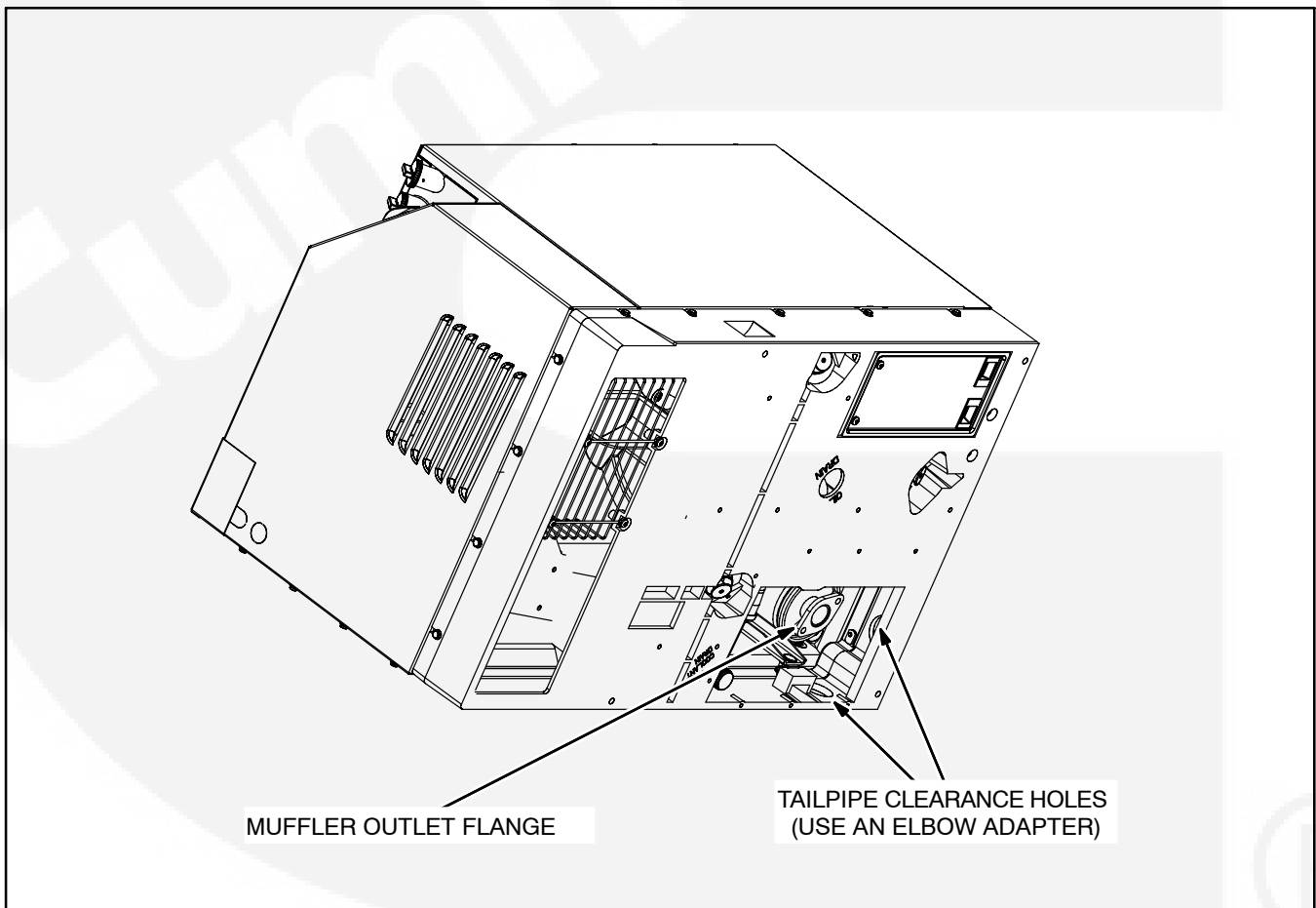

FIGURE 2-3. EXHAUST CONNECTION AT POWER UNIT

Tailpipe

Tailpipe adapter kits are separately available. Use a straight adapter for a tailpipe routed up from below the Power Unit. Use an elbow adapter for a tailpipe routed through the clearance hole in the right or back side of the base of the Power Unit. When connecting and routing the tailpipe:

1. Use 1-3/8 inch ID aluminized steel tubing or equivalent for the tailpipe. (Do not use flexible pipe. Flexible pipe is not gas tight or durable.)
2. Secure the tailpipe or adapter flange to the muffler flange with a gasket and two 5/16-18 bolts.
3. Use U-bolt muffler clamps to connect sections of tailpipe. It is recommended that the overlapping pipe be slotted as shown in Figure 2-4.
4. Use automotive-type tailpipe hangers every 2 to 3 feet (610 to 914 mm). Attach the hangers to steel framework, not to wood or other combustible material.
5. Do not terminate the tailpipe underneath the vehicle. Extend it a minimum of 1 inch (25 mm) beyond the perimeter of the vehicle (Figure 2-5). Support the end of the tailpipe such that it cannot be pushed inward and up under the skirt of the vehicle by backing up into a curb or other obstacle.

Note: Do not terminate the tailpipe underneath a slide-out room (Figure 2-7), unless the bottom of the slide-out, including skirts and moldings, is at least 3 feet above the end of the tailpipe.

6. Do not route the tailpipe such that it will interfere with opening the Power Unit maintenance door or draining engine oil or coolant or restrict the air inlet.
7. Do not route the tailpipe closer than 3 inches (76 mm) to combustible material (wood, felt, cotton, organic fibers, etc.) unless it is insulated or shielded. The temperature of adjacent combustible material must not exceed 194°F (90°C).
8. Do not route the tail pipe near fuel lines or fuel tanks or terminate it below or near a fuel fill opening.
9. Do not terminate the tailpipe such that it is closer than 6 inches (153 mm) to any opening into the vehicle interior (door, window, vent). See Figure 2-6.

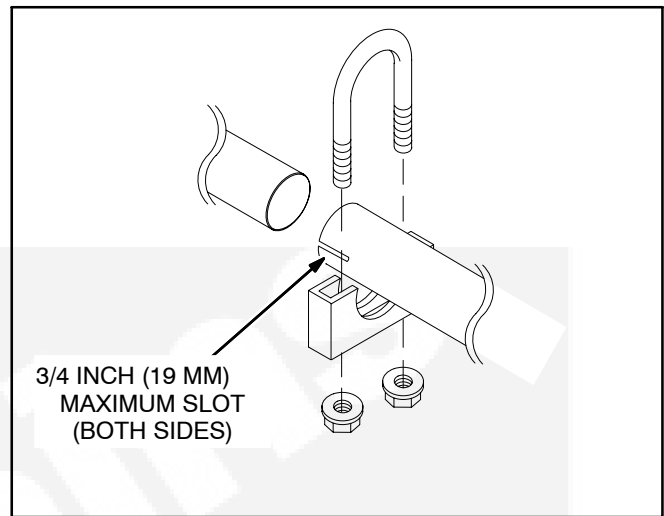

FIGURE 2-4. EXHAUST TAILPIPE CONNECTIONS

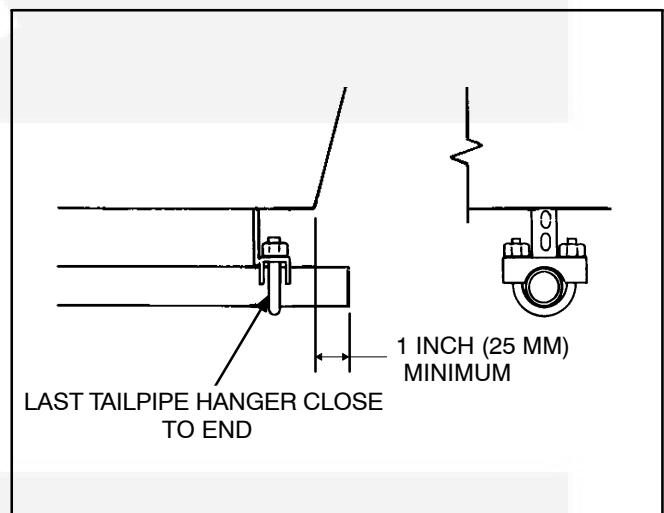

FIGURE 2-5. EXHAUST TAILPIPE TERMINATION

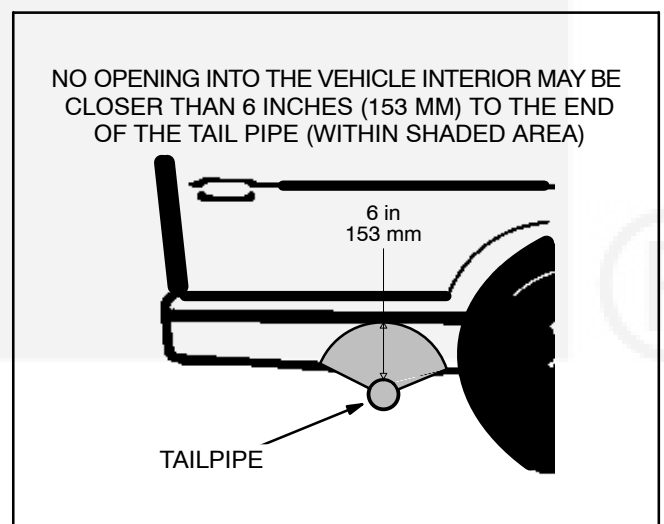

FIGURE 2-6. MINIMUM DISTANCES TO OPENINGS

10. The tail pipe must be visible and accessible along its entire length for inspection and replacement.
11. Route the tailpipe such that it will not likely be struck when the vehicle is moving. Keep it out of the approach and departure angles of the vehicle and above the axle clearance line (Figure 2-7).
12. Do not connect Power Unit exhaust to the vehicle engine exhaust system.

⚠ CAUTION *Interconnecting the engine exhaust systems will allow exhaust condensates and soot to migrate into the engine that is idle, causing engine damage.*

13. *Exhaust back pressure under full load must not exceed 2 inches (51 mm) water column (WC) as measured within 6 inches (154 mm) of the muffler outlet flange.*

⚠ CAUTION *Excessive back pressure can cause loss of performance and engine damage.*

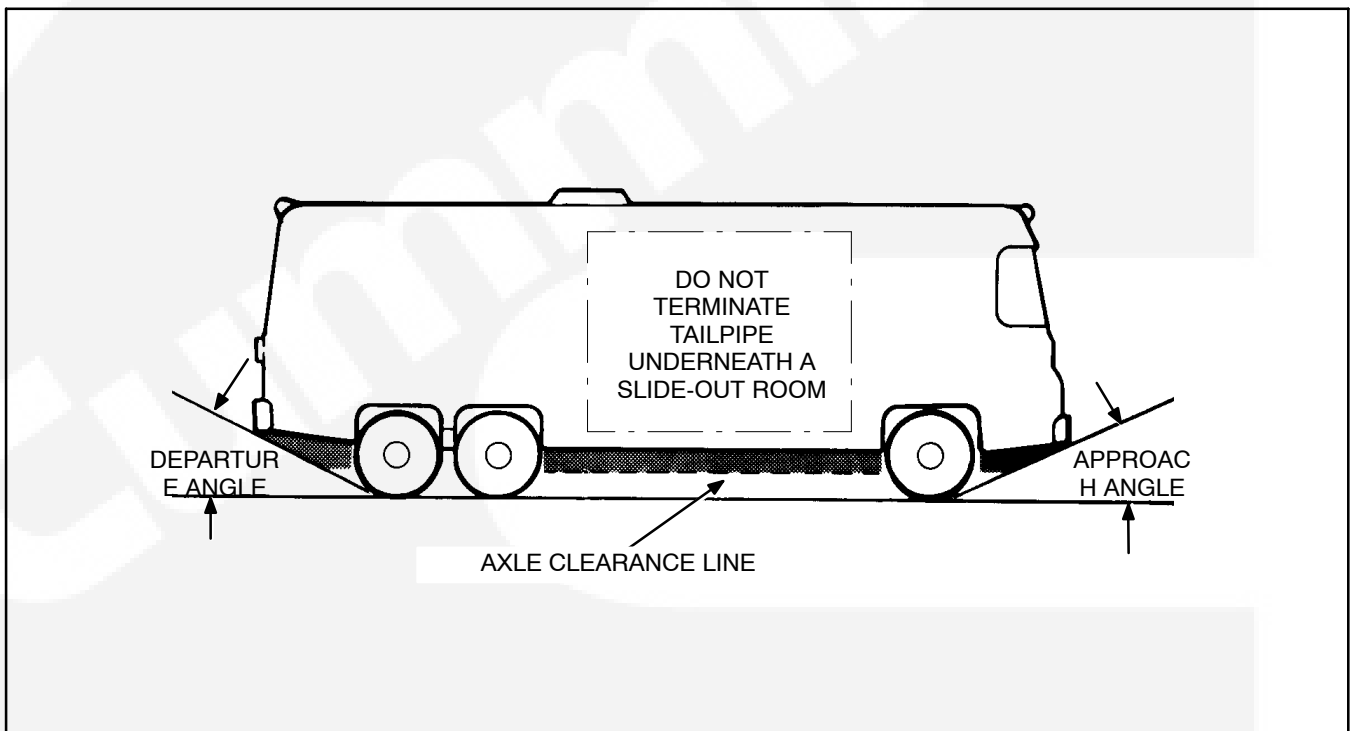

FIGURE 2-7. APPROACH AND DEPARTURE ANGLES AND AXLE CLEARANCE LINE

FUEL CONNECTIONS

⚠ WARNING *Diesel fuel is a combustible and can cause severe personal injury or death. Do not smoke or allow any flame, spark, pilot light, arc-producing equipment, electrical switch or other ignition source around fuel or fuel components, or in areas sharing ventilation. Keep a type ABC fire extinguisher handy.*

Do not interconnect Power Unit and vehicle engine fuel lines. Follow the vehicle chassis manufacturer's instructions when making connections to the vehicle engine fuel tank.

⚠ CAUTION *Either or both engines could starve for fuel if the Power Unit and vehicle engine fuel lines are interconnected. Always use separate fuel lines or a separate fuel tank for the Power Unit.*

To prevent the Power Unit from running the vehicle out of fuel, do not extend the Power Unit fuel pickup tube down into the fuel tank as far as the pickup tube for the vehicle engine.

Fuel lines (supply and return) must have at least a 1/4 inch (6.4 mm) ID. The Power Unit has 1/8 inch NPT fittings for fuel supply and return.

Run the fuel line at or above the top of the fuel tank to reduce the risk of siphoning fuel out of the tank if the

line should break. The maximum fuel pump lift is 36 inches (914 mm).

Route fuel lines away from electrical wiring and hot engine exhaust components. Fuel lines should be accessible for inspection and replacement, protected from damage and secured to prevent kinking, contact with sharp edges and chafing due to vibration.

COOLANT CONNECTIONS

The liquid-cooled electronics cold plate in the Inverter/Charger is cooled by a heat exchanger housed in the Power Unit. For coolant hose connections between the Inverter/Charger and Power Unit refer to *Section 3. Inverter/Charger Installation*.

COMMUNICATIONS CONNECTIONS

Refer to *Section 7. Communications and Input Cables* for Inverter/Charger communications and remote control connections.

BATTERY CONNECTIONS

Refer to *Section 9. Coach Battery Connections*.

AC OUTPUT CONNECTIONS

Refer to *Section 6. AC Connections*.

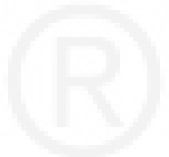

Cummins

This side is intended to be blank



3. Inverter/Charger Installation

LOCATION, MOUNTING AND ENCLOSURE

Refer to the Inverter/Charger Outline Drawing for dimensions (p. E-4).

1. The Inverter/Charger must be located close enough to the Coach Batteries so that the battery cables do not exceed 10 ft (3 meters) in length.
2. In order to fill and prime the Inverter/Charger cooling system, the Inverter/Charger must not be located more than 3 feet (1 meter) higher than the Power Unit.
3. The Inverter/Charger must be located in an enclosure that is dry and affords protection from dust, rain, snow and road splash.
4. The Inverter/Charger must be isolated from batteries, fuel tanks and other sources of flammable or explosive gases.
5. The Inverter/Charger base has six mounting holes. Four 1/4 inch (6 mm) screws must be used to mount it to the floor, wall or roof of the enclosure. Two mounting screws must be in front (terminal side) and two in back.
6. When secured to a wall, the Inverter/Charger must be level and the coolant hose fittings must point to either side, not up or down. This is to prevent coolant from entering the electronic components inside the Inverter/Charger if there is a hose leak. Figure 3-1 illustrates acceptable mounting positions and orientations.
7. There must be a minimum of 1 inch (25.4 mm) clearance on all sides and top of the Inverter/Charger cover and room for making wiring and coolant hose connections.
8. The Inverter/Charger has an internal cooling fan. Air must flow freely from left to right through and out of the enclosure. The size and location of the enclosure and flow of air through it must be such that the Inverter/Charger does not overheat and shut down during normal operation. Refer to *Appendix C. Hot Air Recirculation Test*.

⚠ CAUTION *Inadequate cooling air flow or recirculation of warm air back into the Inverter/Charger can result in shutdowns due to overheating.*



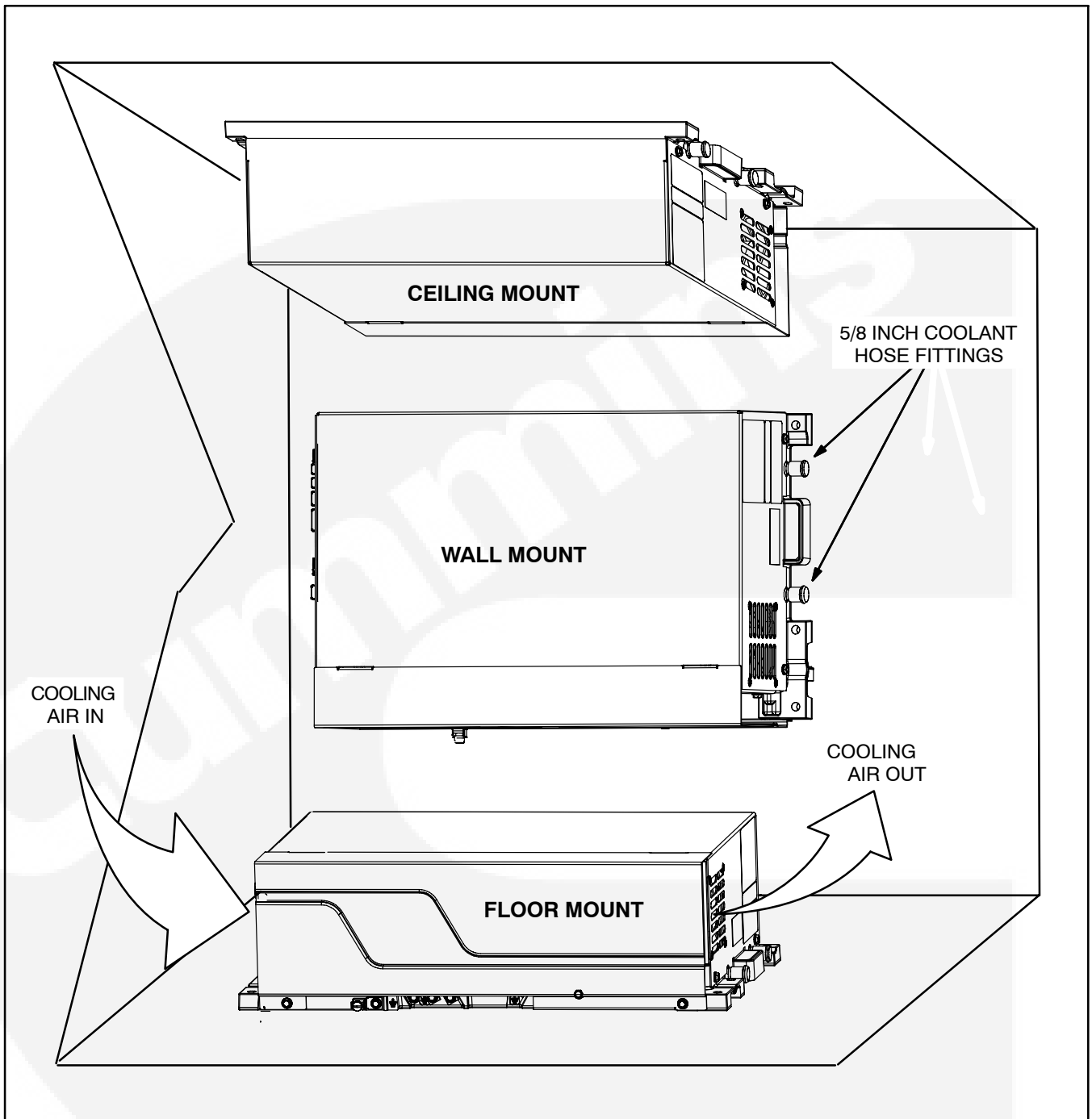

FIGURE 3-1. INVERTER/CHARGER—ACCEPTABLE MOUNTING POSITIONS AND ORIENTATIONS

COOLANT CONNECTIONS

The liquid-cooled electronics cold plate in the Inverter/Charger is cooled by a heat exchanger housed in the Power Unit. Figure 3-2 illustrates the connections.

1. Install two straight or elbowed 3/8 NPT by 5/8 inch ID hose fittings (not provided) into the threaded coolant fittings on the end of the Power Unit. Use thread sealant.
2. Connect two 5/8 inch ID SAE 20R3 coolant hoses between the hose fittings on the Inverter/Charger and the Power Unit. Secure the hoses using the spring hose clamps in the bag pack-

aged with the Inverter/Charger. Refer also to the System Diagram on Page E-2.

3. Route, shield, protect and secure the coolant hoses so that they will not be kinked, cut, abraded, exposed to hot surfaces or damaged by road debris. *Note also that the coolant hoses should be shielded from picking up heat from sources such as exhaust tailpipes.*
4. See the Operator's Manual for instructions on how to fill and prime the cooling system.

ELECTRICAL CONNECTIONS

Refer to *Section 6. AC Connections*, *Section 9. Coach Battery Connections* and *Section 7. Communications and Input Cables*.



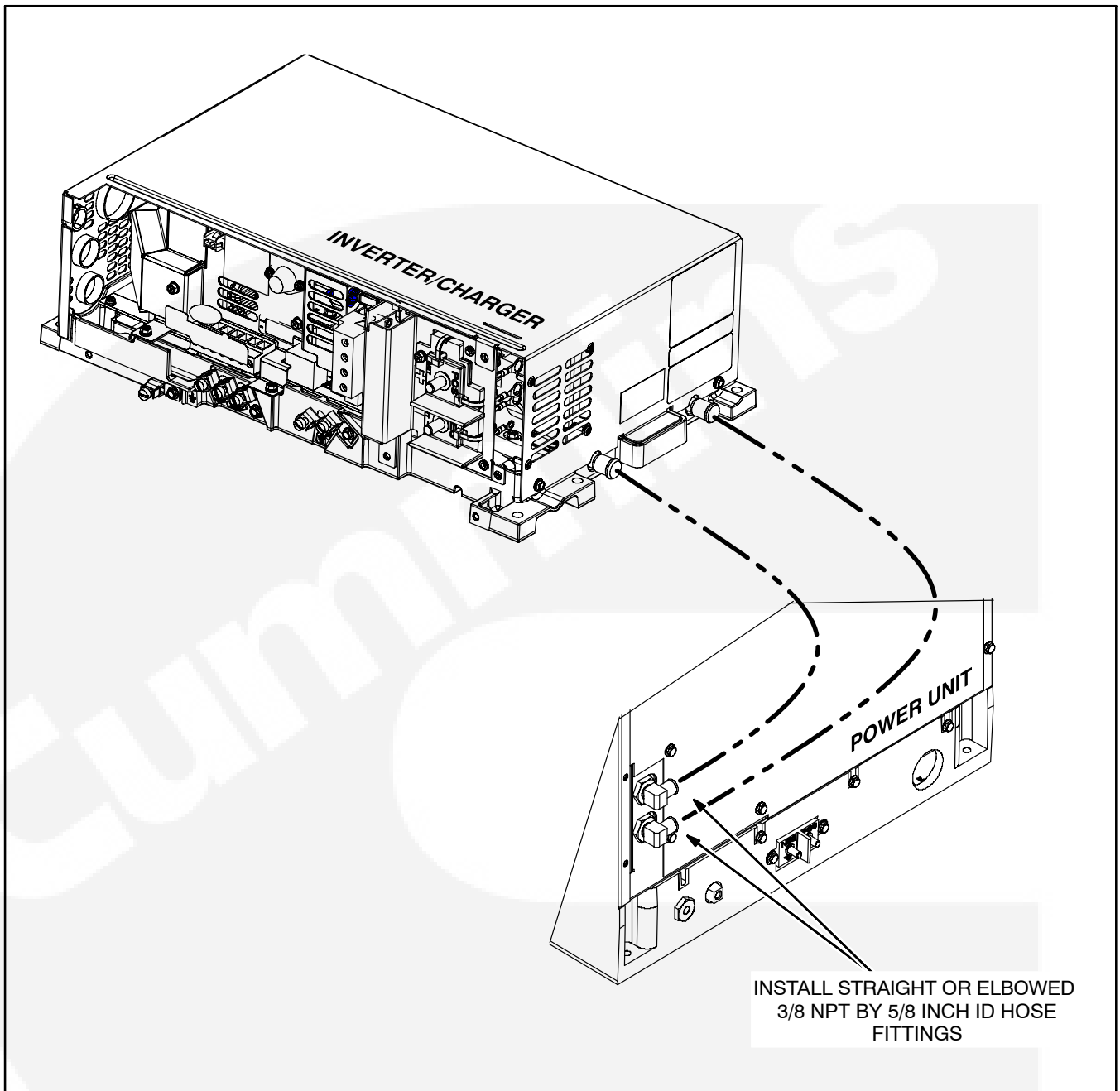

FIGURE 3-2. COOLANT HOSE FITTINGS



4. Transfer Switch Installation

MOUNTING

Refer to the Transfer Switch Outline Drawing (p. E-5) for dimensions.

1. The Transfer Switch must be located in an enclosure that is dry and affords protection from dust, rain, snow and road splash.
2. It must be isolated from batteries, fuel tanks and other sources of flammable or explosive gases.
3. *The Transfer Switch must be wall mounted. Ceiling or floor mounting may cause it to mal-*

function. Secure it to the enclosure wall with four 1/4 inch (6 mm) screws. Any side may be up. Figure 4-1 illustrates wall mounting of the Transfer Switch.

4. There must be a minimum of 1/2 inch (13 mm) clearance on all sides of the Transfer Switch and clearance for removing the cover and making wiring connections.

ELECTRICAL CONNECTIONS

Refer to *Section 6. AC Connections* and *Section 7. Communications and Input Cables* .

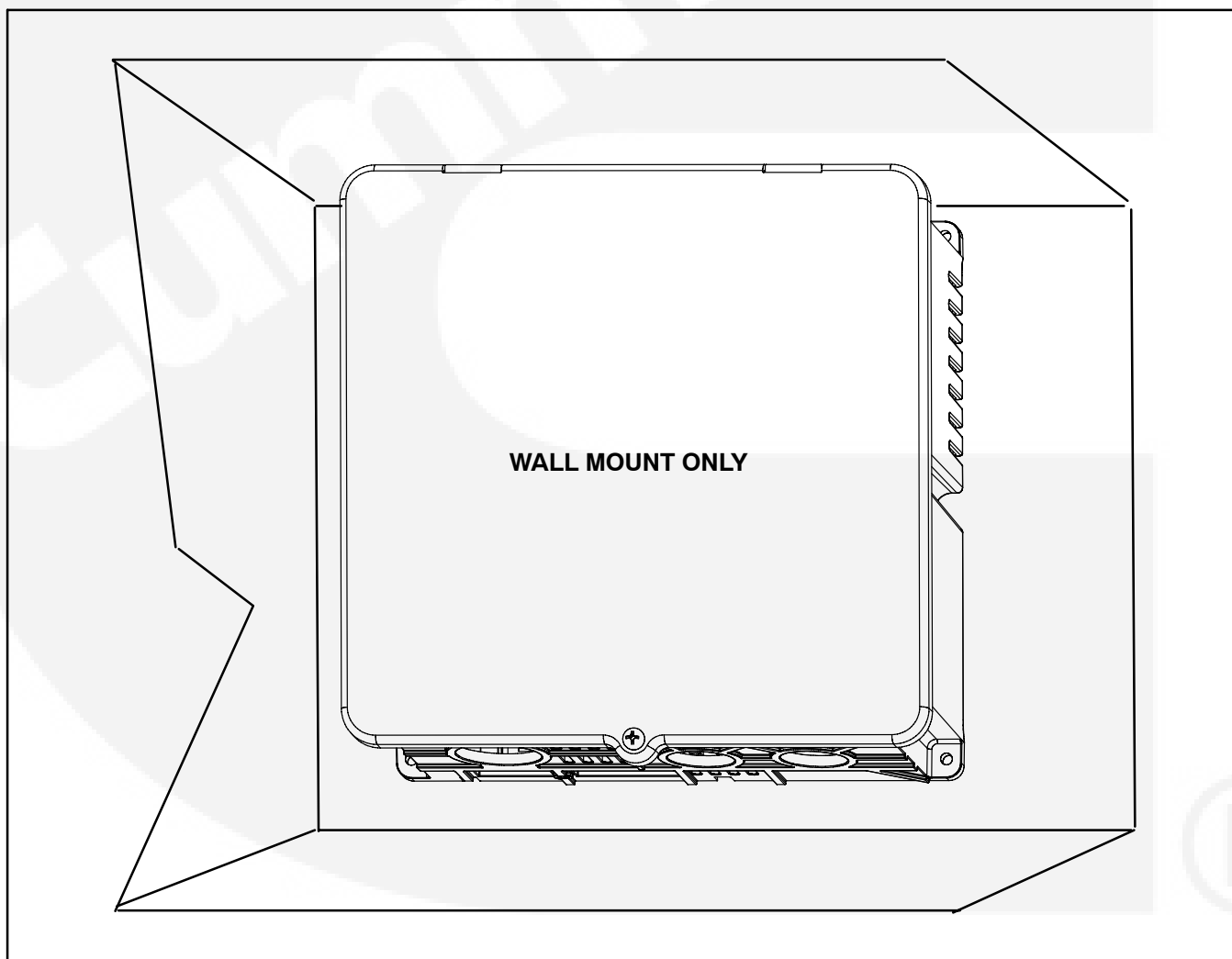

FIGURE 4-1. TRANSFER SWITCH WALL MOUNT

Cummins

This side is intended to be blank



5. Accessory Kit Installations

SHUNT/FUSE BLOCK

The Shunt/Fuse Block (Figure 5-1) is available as Kit 541-1330. Install the assembly in accordance with the Kit Instructions. For connections refer to *Section 9. Coach Battery Connections and Section 7. Communications and Input Cables*.

The shunt is used by the Hybrid Power System to continuously track current to and from the Coach Batteries to determine the State of Charge. The fuse protects the Inverter/Charger if the cables are misconnected.

OPERATOR PANEL

The Operator Panel (Figure 5-2) is available as Kit 541-1333. Install the Operator Panel in accordance with the Kit Instructions. One or two Operator Panels must be connected to the Hybrid Power System for control, configuration and monitoring. For connections refer to *Section 7. Communications and Input Cables*.

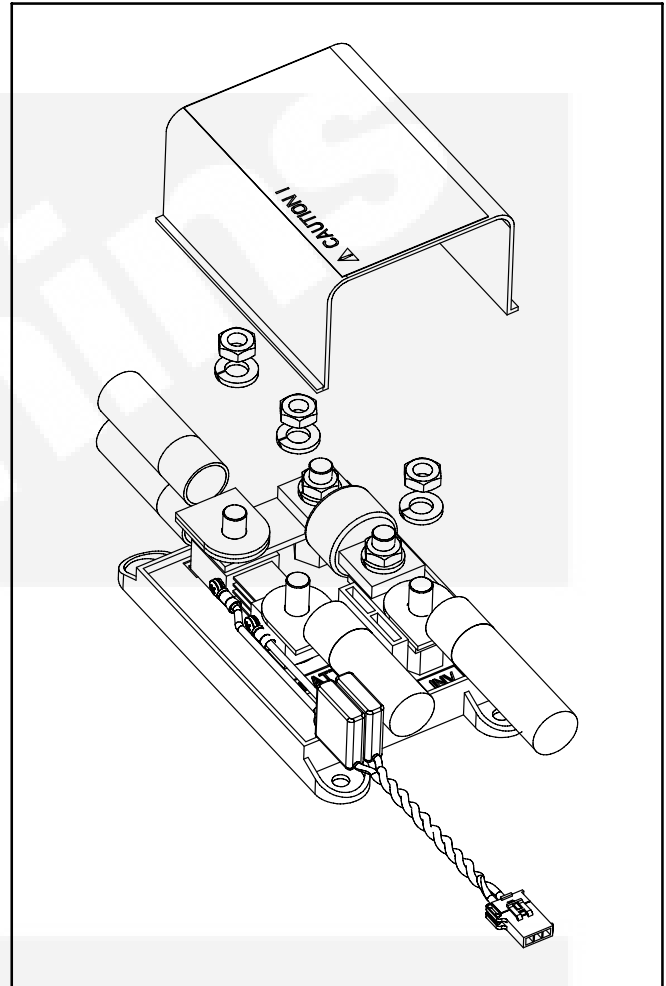

FIGURE 5-1. SHUNT/FUSE BLOCK

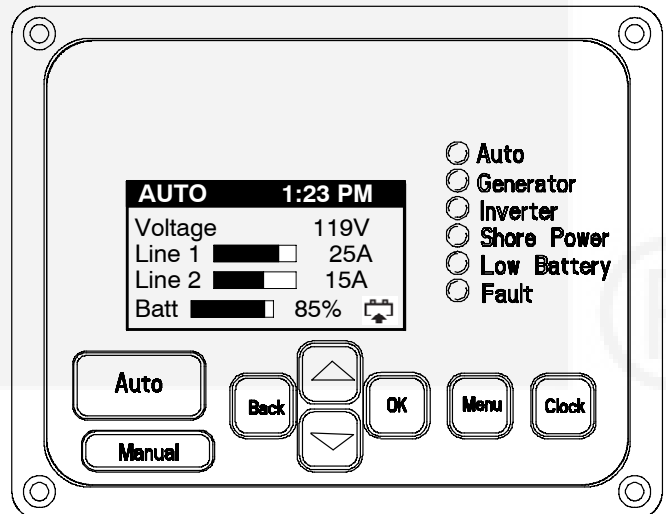

FIGURE 5-2. OPERATOR PANEL

Cummins

This side is intended to be blank



6. AC Connections

GENERAL

⚠️WARNING *Accidental starting of the Power Unit or electrocution by shore power can cause severe personal injury or death. Until ready to startup the Hybrid Power System, make sure that:*

The Power Unit's two remote control connectors (10-Pin and 4-Pin) and the negative (-) battery cable are disconnected and that the circuit breaker is OFF.

The Coach DC Disconnect Switch is in its DISCONNECT position.

Shore Power is not connected.

All AC connections must be performed or supervised by a trained and experienced electrician in accordance with Article 551 of the National Electrical Code (NEC).

For connections refer to the AC System Diagram (p. E-8) and to the Typical Hybrid Power System Diagram on Page E-10.

See Table 6-1 regarding Ground Fault Circuit Interrupters (GFCIs) that are acceptable for use with the Hybrid Power System.

⚠️CAUTION *Risk of electric shock. Only use the GFCIs listed in Table 6-1 . Other types may not function properly with this equipment.*

TABLE 6-1. ACCEPTABLE GFCI MODELS

PASS & SEYMOUR	2094
PASS & SEYMOUR	1594
LEVITON	8599
LEVITON	8899
COOPER WIRING DEVICES	XFG20
COOPER WIRING DEVICES	XFG15

Use vibration-proof switches and controls to prevent the opening and closing of circuits while the vehicle is in motion.

Seal all conduit openings into the vehicle interior to keep out exhaust gas. Apply silicone rubber or equivalent sealant inside and outside each conduit connector. (Flexible conduit is not vapor-tight and will allow exhaust gas to enter along the wires if not sealed.)

⚠️WARNING *EXHAUST GAS IS DEADLY! Seal all wiring openings into the vehicle interior to keep out exhaust gas.*

Route, shield, protect and secure AC wiring so that it will not be cut, abraded, exposed to hot surfaces or damaged by road debris. Keep AC wiring away from fuel lines, battery cables and control wiring.

⚠️WARNING *Routing AC wiring with fuel lines can lead to fire. Keep AC wiring away from fuel lines.*

Routing AC wiring with battery cables or control wiring can lead to electric shock unless each conductor is insulated for the highest voltage.



AC WIRE STRIP LENGTHS AND TERMINAL TORQUES

Refer to Table 6-2 for required wire strip lengths and terminal torques.

When stranded conductors are used, it is recommended that copper ferrules, available for the various wire gauges, be crimped on the stripped ends of the conductors to facilitate terminal connections. Otherwise, re-torque the terminals after a few minutes in case individual strands have spread out, loosening the connection.

**TABLE 6-2. AC WIRE STRIP LENGTHS AND
TERMINAL TORQUES**

Terminal	Strip Length	Torque
Power Unit Terminals	5/8 inch (16 mm)	22 in-lbs (2.5 N-m)
Transfer Switch Terminals	7/8 inch (22 mm)	25 in-lbs (2.8 N-m)
Transfer Switch Ground Terminals	-	20 in-lbs (2.3 N-m)
Inverter/Charger 4-Wire Terminal Block	7/8 inch (22 mm)	25 in-lbs (2.8 N-m)
Inverter/Charger 7-Wire Terminal Block	9/16 inch (14 mm)	20 in-lbs (2.3 N-m)
Inverter/Charger Ground Terminals	-	20 in-lbs (2.3 N-m)

SHORE POWER FUSES

Install 60 Amp Class RK1 or K5 fuses between the Transfer Switch and the shore connector.

SHORE PASS-THROUGH CIRCUITS

The main AC distribution panel must provide a 30 amp branch circuit protective device for the circuit to the Inverter/Charger for battery charging and pass through to the AC sub-distribution panel.

CONNECTIONS AT TRANSFER SWITCH

Install wiring and wiring system components in accordance with NEC requirements.

The Transfer Switch has three terminal blocks and three cable openings for connections to shore pow-

er, Inverter/Charger and AC distribution panel (Figure 6-1).

Use approved 1-3/8 inch and 1-3/4 inch trade-size conduit fittings, strain relief bushings or NM cable clamps that will not interfere with the Transfer Switch structure, that are compatible with the wiring type and size used and that provide strain relief and protection for the cables passing through.

Wiring gauges must be as specified on the System Diagram (p. E-2). Refer to Page E-5 to make connections at the designated terminals on the Transfer Switch. Strip the ends of the wires and torque the terminals in accordance with Table 6-2.

Secure the cover.



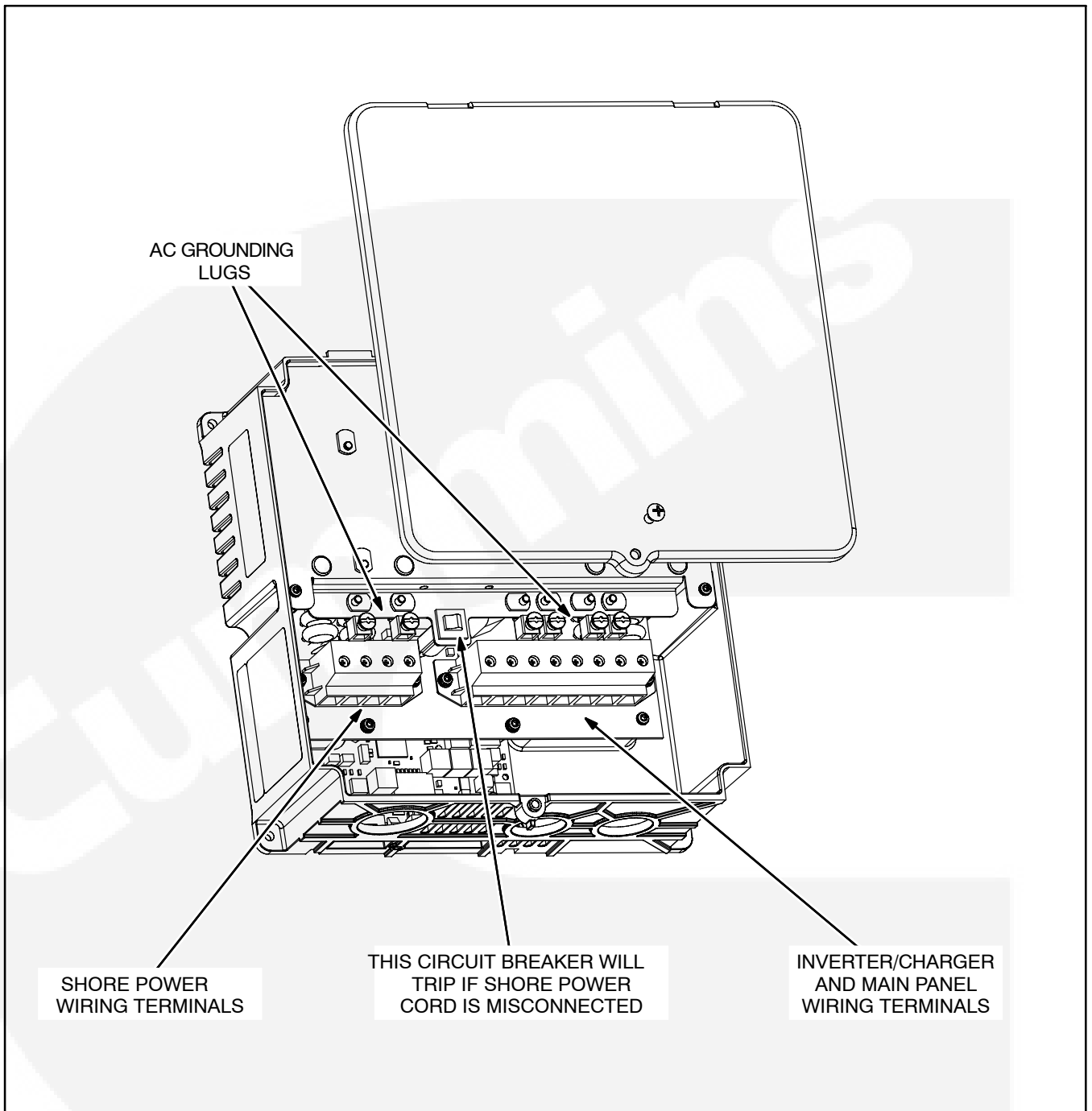
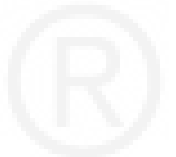

FIGURE 6-1. AC WIRING TERMINALS ON TRANSFER SWITCH



CONNECTIONS AT INVERTER/CHARGER

Install wiring and wiring system components in accordance with NEC requirements.

The Inverter/Charger has four terminal blocks and four cable openings for connections to the Power Unit, Transfer Switch, main distribution panel and sub distribution panel (Figure 6-2). Use the 1-1/4 inch and 3/4 inch trade-size NM cable clamps or conduit connectors packaged with the Inverter/Charger to provide strain relief or protection for the cables passing through.

Wiring gauges must be as specified on the System Diagram (p. E-2). Refer to Pages E-4 and E-8 to make connections at the designated terminals on the Inverter/Charger. Strip the ends of the wires and torque the terminals in accordance with Table 6-2.

The Inverter/Charger must also be grounded to the coach chassis with a No. 8 AWG cable. Use the chassis grounding lug on the frame of the Inverter/Charger.

Secure the cover over the terminals when all connections have been made.

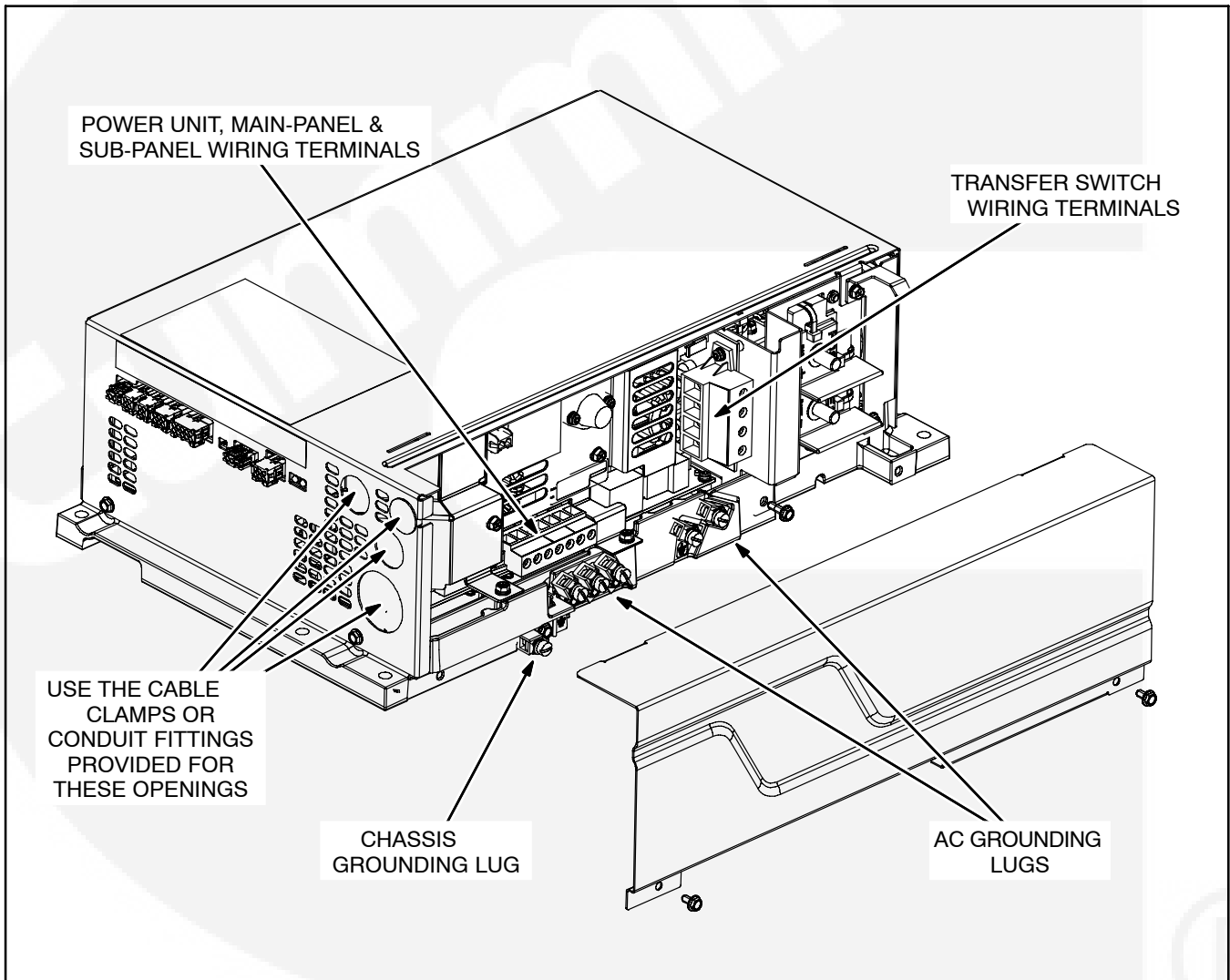

FIGURE 6-2. AC WIRING TERMINALS ON INVERTER/CHARGER

CONNECTIONS AT POWER UNIT

⚠WARNING *Do not connect the Power Unit to the Coach AC circuits. Its high output voltages can damage equipment and cause death or severe personal injury.*

The Power Unit has a terminal block (Figure 6-3) for power output connections to the Inverter/Charger. Its output is 3-Phase and varies in frequency and voltage as load varies.

Install wiring and wiring system components in accordance with NEC requirements. Use approved conduit fittings or strain relief bushings that will not interfere with the Power Unit structure, that are compatible with the wiring type and size used, and that protect wiring passing through the sheet metal openings. Provide strain relief.

Wiring gauges must be as specified on the System Diagram (p. E-2). Refer to Page E-3 to make connections at the designated terminals on the Power Unit. Strip the ends of the wires and torque the terminals in accordance with Table 6-2.

Secure the cover over the terminals when all connections have been made.

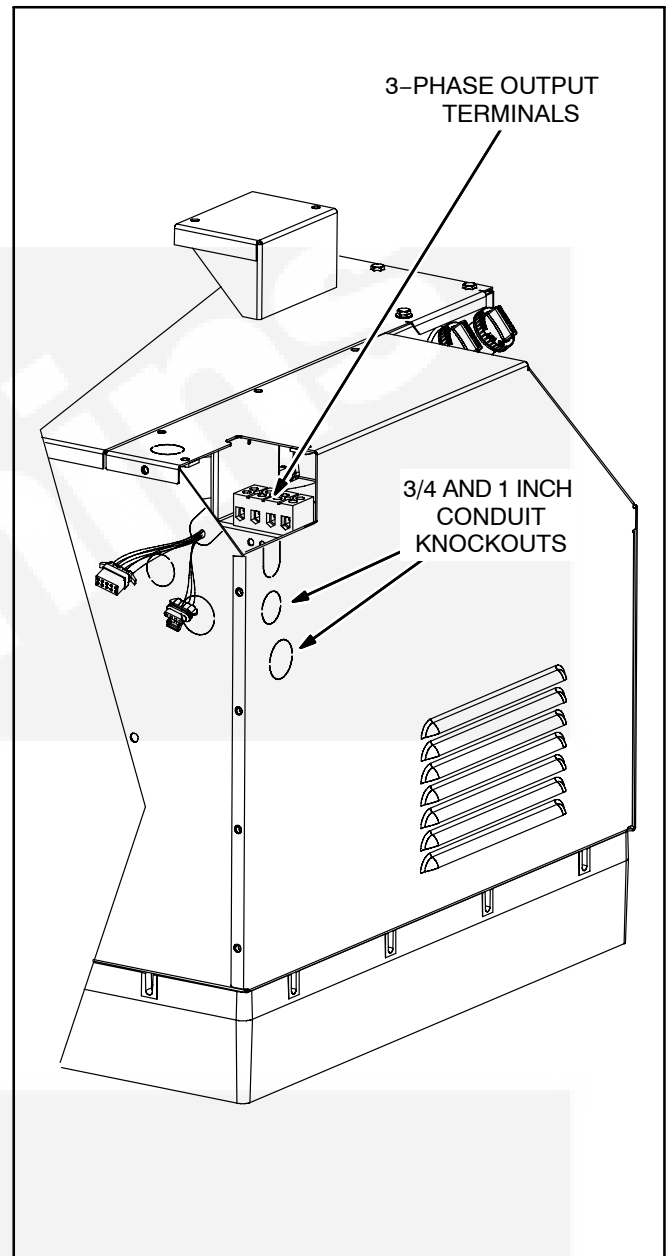

FIGURE 6-3. OUTPUT WIRING TERMINALS

7. Communications and Input Cables

GENERAL

⚠️WARNING *Unexpected starting of the Power Unit or connection to Shore Power during installation or service can lead to severe personal injury or death. Until ready to start up the Hybrid Power System, make sure to:*

Push the Power Unit circuit breaker OFF and disconnect the 10-Pin and 4-Pin remote control connectors and battery cables from the Power Unit. Insulate the end of the positive (+) battery cable to keep it from touching chassis ground.

Turn the Coach DC Disconnect Switch to its DISCONNECT position.

Disconnect Shore Power.

For connections refer to the Communications Cable System Diagram (p. E-9) and to the Typical Hybrid Power System Installation Diagram on Page E-10.

Seal all wiring openings into the vehicle interior with silicone rubber or equivalent sealant to keep out exhaust gas.

⚠️WARNING **EXHAUST GAS IS DEADLY!** *Seal all wiring openings into the vehicle interior to keep out exhaust gas.*

Route or protect all communications and input cables so that they will not be cut or abraded, exposed to hot surfaces or damaged by road debris. Keep communications cables away from AC wiring.

Table 7-1 lists the communications and input cable harnesses that are available for interconnecting the components of the Hybrid Power System. Refer also to the harness drawings on Page E-11.

Note: The ends of a harness may have different connectors. Try the connector on the other end if the first does not connect.

TABLE 7-1. AVAILABLE COMMUNICATIONS AND INPUT CABLE HARNESSSES

CABLE	PART NUMBER
Inverter/Charger J12 to Power Unit P2 (CAN)	541-1344 (30 ft), 541-1345 (50 ft) or 541-1427 (60 ft)
Inverter/Charger J13 to Transfer Switch J2 (CAN)	541-1346 (15 ft) or 541-1347 (30 ft)
Inverter/Charger J15 to Shunt Input	541-1350 (15 ft)
Transfer Switch J4 to Safety Signal and Load Demand	541-1351 (6 inches)
Inverter/Charger J15 to Wakeup Input	541-1378 (6 inches)
Transfer Switch J5 to Operator Panel	541-0919 (25 ft) or 541-0932 (50 ft)



POWER UNIT CONNECTIONS

⚠WARNING *Unexpected starting of the Power Unit or connection to Shore Power during installation or service can lead to severe personal injury or death. Until ready to start up the Hybrid Power System, make sure to:*

Push the Power Unit circuit breaker OFF and disconnect the 10-Pin and 4-Pin remote control connectors and battery cables from the Power Unit. Insulate the end of the positive (+) battery cable to keep it from touching chassis ground.

Turn the Coach DC Disconnect Switch to its DISCONNECT position.

Disconnect Shore Power.

General

Power Unit connectors **P2** and **P8** are stowed in the output junction box (Figure 7-1). Remove the cover and pull out the harnesses. Remove either of the two slotted knockouts, insert the harness bushing and secure the cover.

To Inverter/Charger

Connect Power Unit connector **P2** to Inverter/Charger connector **J12** using an appropriate cable harness. Refer to Table 7-1.

To Remote Control Switch

Connect Power Unit connector **P8** to the remote control switch. Refer to Table 7-1.

Refer to the Power Unit outline drawing on Page E-3 for connector pinouts and mating parts.

Use insulate 18 AWG conductors for remote control switch connections.

The remote control switch should be a two-pole, momentary-contact, center-return/center-off type of switch. It may include a status light.

The total load connected to **P8-B** (Status Light) or to **P8-F** (Switched B+) must not exceed 2 amps.

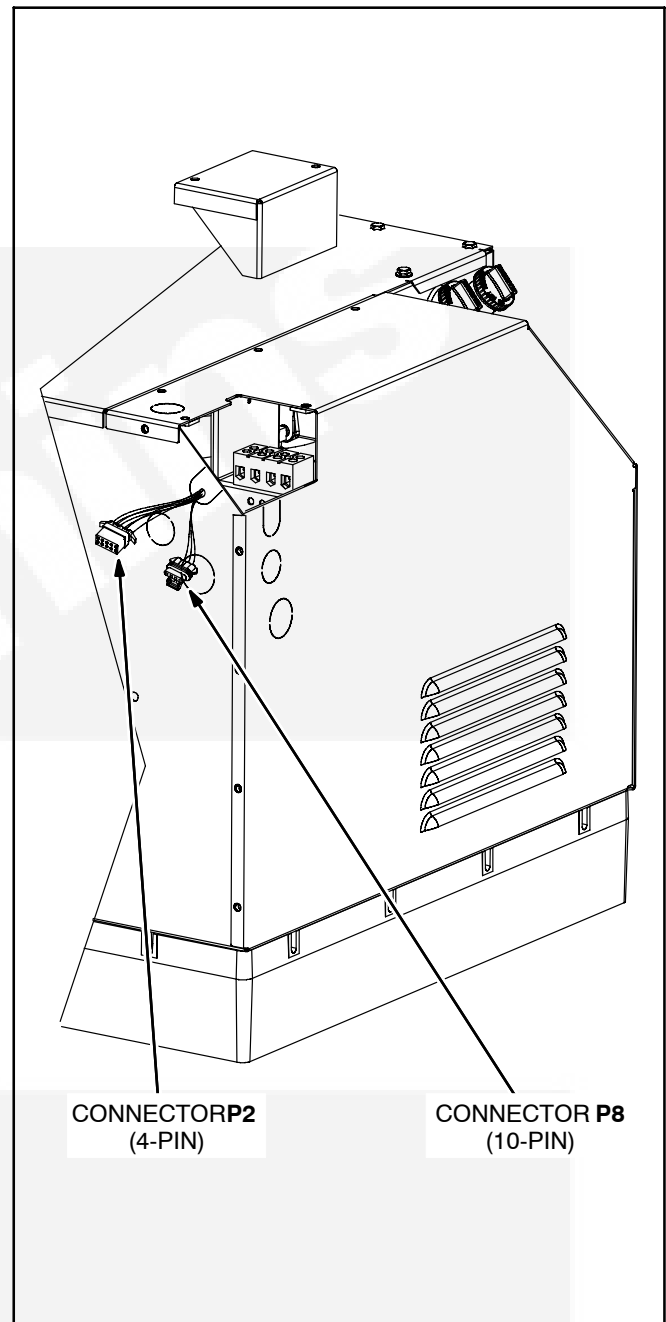

FIGURE 7-1. POWER UNIT CONNECTORS

LOAD DEMAND INPUT

The Hybrid Power System can be connected to receive a load signal from different kinds of AC equipment, such as air conditioners, to automatically start Generator Mode when AUTO has been enabled.

Provide for a 12 VDC signal to Transfer Switch connector **J4** (Figure 7-2). Polarity must be correct. The switching contacts may be in either the positive (+) or negative (-) side of the circuit. The Hybrid Power System will accept either an active HIGH or active LOW signal.

When using 6 inch pigtail wiring harness 541-1351 to connect the signal to Transfer Switch connector **J4**, butt-splice insulated 18 AWG wiring to the pigtails to complete the circuit. Refer to Table 7-1.

See INPUT SETUP (p. A-20) to configure the Hybrid Power System for the type of signal used.

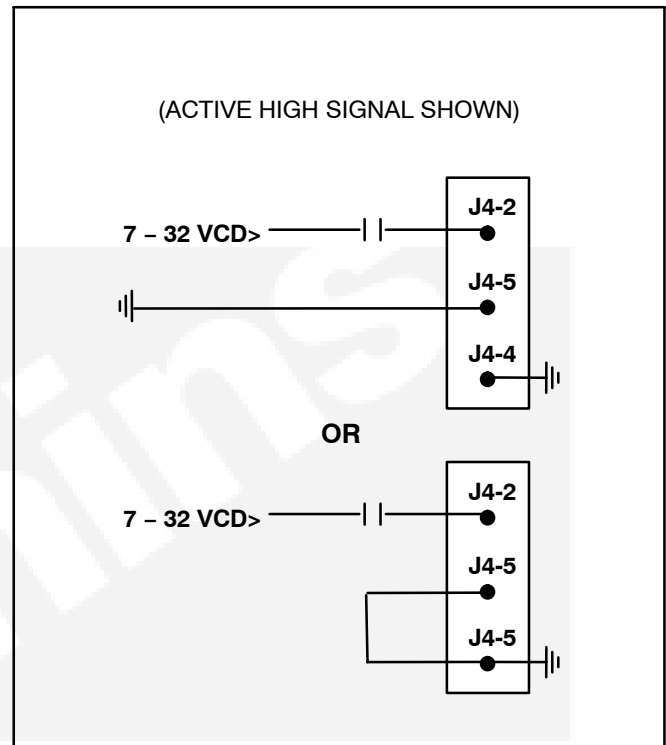

FIGURE 7-2. TYPICAL LOAD DEMAND SIGNAL

AUTO SAFETY INPUT

A safety input signal must be connected to disable AUTO each time the coach is moved. The coach's ignition switch, parking brake or transmission Park/Neutral switch are recommended inputs for this signal.

Provide for a 12 VDC signal to Transfer Switch connector **J4** (Figure 7-3). Polarity must be correct. The switching contacts may be in either the positive (+) or negative (-) side of the circuit.

When using 6 inch pigtail wiring harness 541-1351 to connect the signal to Transfer Switch connector **J4**, butt-splice insulated 18 AWG wiring to the pigtails to complete the circuit. Refer to Table 7-1.

See INPUT SETUP (p. A-20) to configure the Hybrid Power System for the type of signal used.

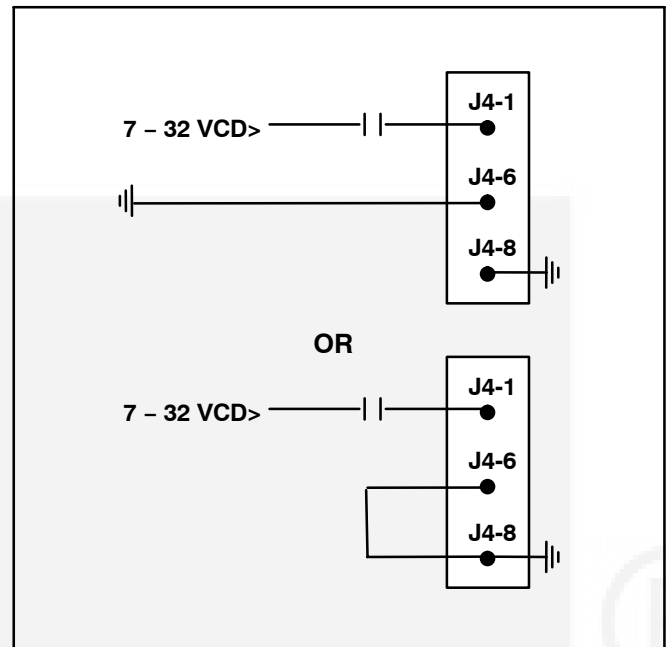

FIGURE 7-3. TYPICAL AUTO SAFETY SIGNAL

BATTERY SAVER SIGNAL

The Hybrid Power System requires installation of a customer-provided (wakeup) signal at Inverter/Charger connector **J15**.

Figure 7-4 illustrates connections with the Coach DC Disconnect Switch to provide the signal. Connect **J15-1** to the load side of the DC Disconnect Switch. Connect pin **J15-3** to ground.

cal Hybrid Power System Installation Diagram on Page E-10.

Note: The Coach DC Disconnect Switch and all DC loads must be connected to the LOAD terminal of the Shunt/Fuse Block.

When using 6 inch pigtail wiring harness 541-1182, butt-splice insulated 18 AWG wiring to the pigtails to complete the circuit. Refer to Table 7-1.

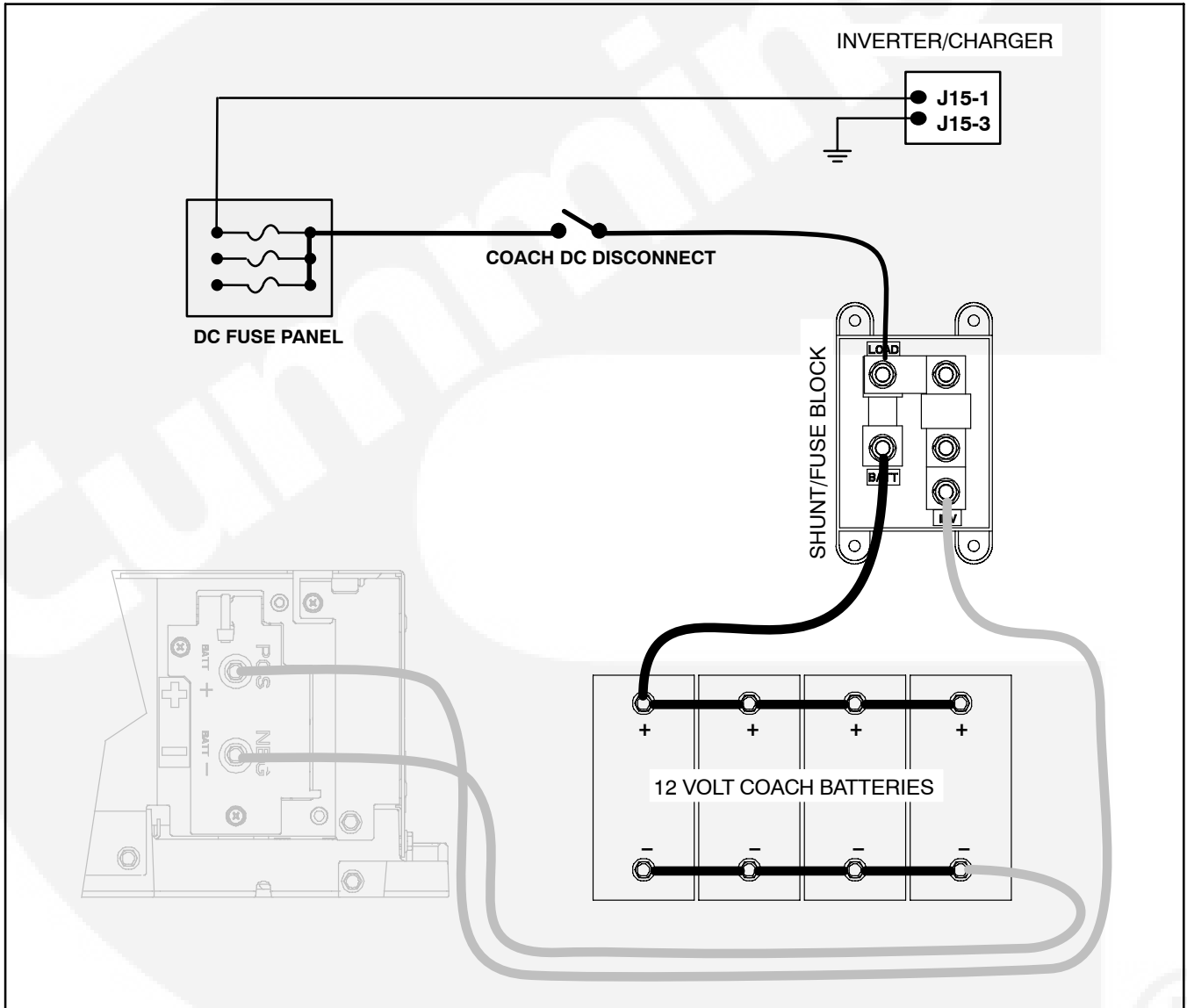

FIGURE 7-4. TYPICAL COACH DC DISCONNECT SWITCH AND BATTERY SAVER SIGNAL CONNECTIONS

SHUNT INPUT

Connect the shunt input connector to Inverter/Charger connector **J24** using an appropriate cable harness. Refer to Table 7-1.

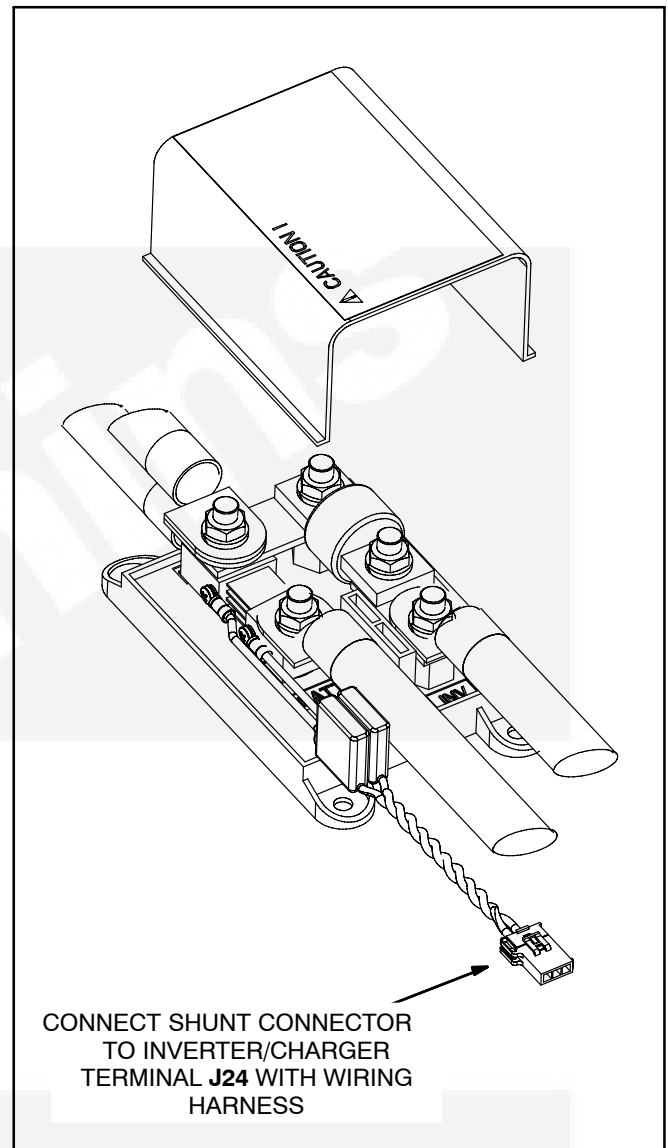

FIGURE 7-5. CONNECTIONS AT SHUNT/FUSE BLOCK

BATTERY TEMPERATURE SENSOR

The battery temperature sensor (Figure 7-6) is packaged with the Inverter/Charger. It is a thermistor in the shank of a 3/8 inch ring terminal for bolting to a battery terminal. The sensor has a 15 foot lead with a connector for plugging into Inverter/Charger connector **J11**.

Bolt the battery temperature sensor to a centrally located positive (+) terminal for representative Battery Bank temperature sensing. See *Appendix B. Battery Connections*.

The battery temperature sensor must be installed for optimum Inverter/Charger performance and battery use.

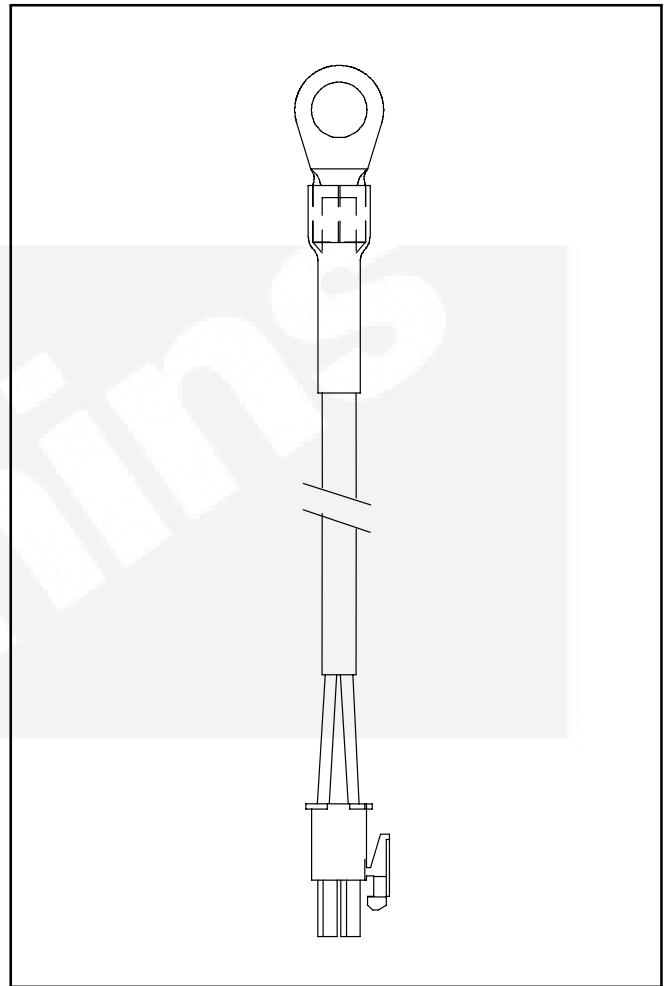

FIGURE 7-6. BATTERY TEMPERATURE SENSOR



8. Coach Battery Installation

GENERAL

The coach manufacturer is responsible for the selection and installation of the coach batteries.

⚠WARNING *Battery acid can cause severe burns. Always wear safety glasses and protective clothing when working with batteries. If acid gets in your eyes or on your skin, flush with water for 15 minutes and get medical attention.*

Remove hanging jewelry, rings and bracelets before working on batteries. They can short and weld to battery terminals causing severe burns.

Lead-Acid Batteries produce explosive hydrogen gas that can lead to severe personal injury—Do not smoke near batteries—Disconnect all loads and inputs and observe the proper Battery Connect / Disconnect Sequences.

Secure DC terminal protective covers to prevent accidental shorting with metal tools.

BATTERY TYPE

⚠WARNING *Do not use batteries of other types than specified for use with the Hybrid Power System. They can explode, causing severe personal injury.*

⚠CAUTION *Engine starting batteries are not suitable for deep-cycle service. They have thin plates designed for brief, high-current service that warp and become unserviceable as a result of the heat generated in deep-cycle service.*

The Hybrid Power System is designed for use only with deep-cycle batteries of the Wet Cell, Gel Cell (GEL) or Absorbed Glass Mat (AGM) types. Other types of batteries can explode when subjected to the charging/inverting duty cycle of this application.

The installer must configure the Hybrid Power System for the type of batteries installed, unless Wet Cell (default). This is done at the Operator Panel. See BATTERY SETUP (p. A-21).

BATTERY ENCLOSURE

⚠WARNING *Arcing can ignite the explosive hydrogen gas given off by the batteries, causing severe personal injury. The battery enclosure must be ventilated and must isolate the battery from spark-producing equipment.*

Batteries must be mounted in an enclosure isolated from spark-producing equipment such as the Inverter/Charger or Power Unit. The compartment must have openings of at least 1.7 square inches (11 square centimeters) per battery at the top and bottom for ventilation of battery gasses. It should be located such that spills and leaks will not drip acid on fuel lines, wiring and other equipment that could be damaged.

BATTERY VOLTAGE

The Coach Batteries must be interconnected for 12 Volt output. See *Appendix B. Battery Interconnections* on how to connect batteries to obtain 12 Volts.

BATTERY CAPACITY

Deep cycle battery capacity is rated in terms of Amp-Hours (AHRS). Use the “20 Hour Battery Rating” to determine the capacity of the coach battery bank. This rating is the maximum AHRS a battery can deliver in 20 hours before its output drops to 10.5 volts.

The Coach Batteries must have a capacity of not less than 400 AHRS, otherwise battery boost performance may not be acceptable. More capacity may be required depending on coach design. Battery AHRS should be twice the estimated AHRS of power consumption. That way the batteries are less likely to operate below half charge, which reduces battery life.

See *Appendix B. Battery Interconnections* on how to interconnect batteries to obtain the required Coach Battery Capacity (AHRS).

CONNECTIONS TO COACH BATTERIES

For connections to the Coach Batteries refer to *Section 9. Coach Battery Connections*.

Cummins

This side is intended to be blank



9. Coach Battery Connections

GENERAL

General

All connections must be performed or supervised by a trained and experienced electrician in accordance with ANSI/RVIA-12V—Standard for Low Voltage Systems in Conversion and Recreational Vehicles.

⚠WARNING *Battery acid can cause severe burns. Always wear safety glasses and protective clothing when working with batteries. If acid gets in your eyes or on your skin, flush with water for 15 minutes and get medical attention.*

Remove hanging jewelry, rings and bracelets before working on batteries. They can short and weld to battery terminals causing severe burns.

Lead-Acid Batteries produce explosive hydrogen gas that can lead to severe personal injury—Do not smoke near batteries—Disconnect all loads and inputs and observe the proper Battery Connect / Disconnect Sequences.

Secure DC terminal protective covers to prevent accidental shorting with metal tools.

Battery Cable Routing

⚠WARNING *Routing battery cables with fuel lines can lead to fire and severe personal injury or death. Keep battery cables away from fuel lines.*

Routing AC wiring with battery cables or control wiring can lead to electric shock unless each conductor is insulated for the highest voltage.

Route battery cables away from fuel lines, AC wiring and hot engine exhaust components. Battery cables must be accessible for inspection and replacement, protected from damage and secured to prevent chafing due to vibration.

It is recommended that the positive (+) and negative (–) cables be run side by side and tied to chassis

members to reduce cable movement due to the magnetic forces induced by the large cable currents.

Terminal Torques

Refer to Table 9-1 for required DC terminal torques. A lock washer must be used with each terminal nut at each DC terminal.

TABLE 9-1. THREADED-STUD TERMINAL TORQUES

Terminal	Torque
Shunt/Fuse Block Terminals	19 ft-lbs (26 N-m)
Inverter/Charger Terminals	12 ft-lbs (16 N-m)
Power Unit Terminals	7.5 ft-lbs (10 N-m)
Battery Terminals	Manufacturer's Recommendations

Connect/Disconnect Sequences

The high capacitance of the Inverter/Charger can cause sparking that can ignite the explosive battery gases when the cables are connected or disconnected. To reduce sparking at the batteries:

1. Disconnect Shore Power (to discontinue charging)
2. Turn the Coach DC Disconnect Switch to its Disconnect position (to disconnect DC loads and power down the Hybrid Power System)
3. Observe this **Connect Sequence**:
 - A. Connect positive (+) cable at Batteries and then at Inverter/Charger.
 - B. Connect negative (–) cable at Batteries and then at Inverter/Charger.
4. Or this **Disconnect Sequence**:
 - A. Disconnect negative (–) cable from Inverter/Charger and then from Batteries.
 - B. Disconnect positive (+) cable from Inverter/Charger and then from Batteries.

INVERTER/CHARGER CONNECTIONS

Figure 9-1 illustrates how to connect the Inverter/Charger to the batteries. The cable from the Shunt/Fuse Block should be the only cable connected to the positive (+) terminal of the Coach Batteries.

⚠ WARNING *Accidental starting, sparks and high voltage can cause severe personal injury or death. Do not connect to the Coach Batteries or to Shore Power until so instructed in “Appendix C. Installation Review and Startup.”*

Shunt/Fuse Block

Install the Shunt/Fuse Block (p. 5-1) in accordance with its kit instructions.

Battery Cables

Refer to Table 9-2 for the required gauge and maximum permitted length of each cable in the Inverter/Charger DC circuit.

TABLE 9-2. BATTERY CABLE LENGTH & GAUGE

Cable	Required Gauge	Maximum Length
Shunt (INV) to Inverter/Charger (+)	4/0 AWG	10 feet (3 meters)
Inverter/Charger (-) to Battery (-)	4/0 AWG	10 feet (3 meters)
Battery (+) to Shunt (BATT)	4/0 AWG	18 inches (45 cm)
Inter-Battery Connecting Cables	4/0 AWG	As Short as Practical

⚠ CAUTION *Use of cables not meeting these minimum specifications can result in excessive voltage drop and consequent loss of Inverter/Charger performance.*

Cable Terminals

Battery cable lugs must be UL Recognized and crimped using approved tools. See Table 9-3 for

recommended ring cable lugs and associated crimping tools. Insulate the lug shanks with shrink-wrap insulation to prevent stray wire strands from shorting to other conductors.

Use 3/8 inch ring cable lugs at the Inverter/Charger and Shunt/Fuse Block and appropriately sized ring cable lugs at the batteries.

TABLE 9-3. RECOMMENDED CABLE LUGS AND CRIMPING DIES

Terminal Size	Thomas & Betts	Amp
4/0 AWG Ring Terminal	BAL 4038	321878
Crimp Tool/Dies	TBM5-SV or TBM5V	45445(4/0)*
*These crimping nest and indent dies are recommended for use only with AMP Hydraulic Foot Pump (AMP PN 69325-3), and with Dyna-Crimp Hydraulic Power Units (Amp PNs: 69120-1 [115 VAC] and 69120-2 [230 VAC]), and are to be used with the “C” style head.		

Connections

Route the cables from the Inverter/Charger and connect the positive (+) cable to the Shunt/Fuse **INV** terminal. Do not connect the other end or the negative (-) cable at this time. Connect the positive (+) cable from the batteries to the Shunt/Fuse **BATT** terminal. Do not connect the other end to the batteries at this time.

Make sure battery polarity is correct.

⚠ CAUTION *Damage as a result of reverse polarity is not covered under Warranty.*

Torque the terminal nuts in accordance with Table 9-1. (The terminal lock washers and nuts are in the bag packaged with the Inverter/Charger.)

Secure terminal covers when all connections have been made.

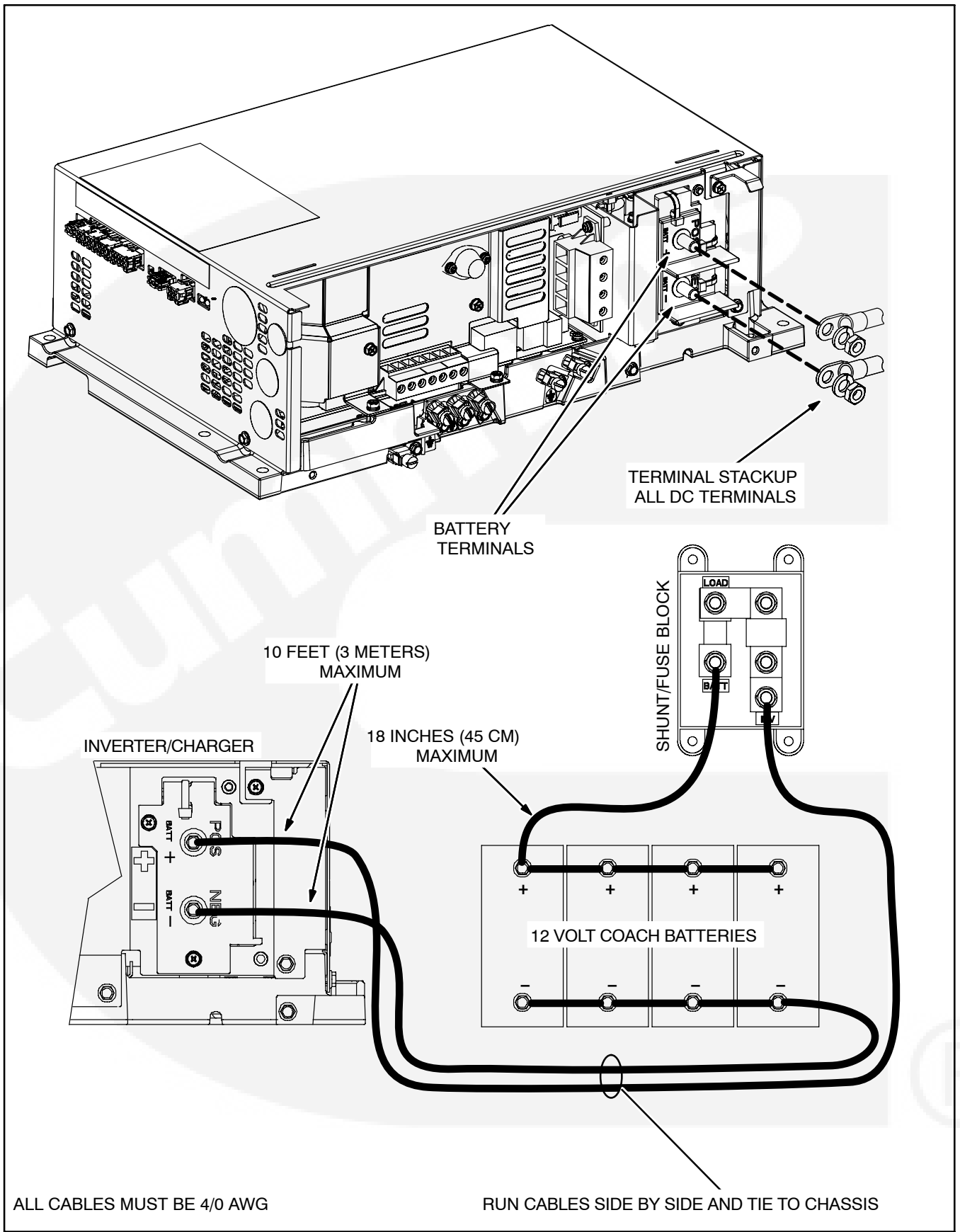

FIGURE 9-1. INVERTER/CHARGER BATTERY CONNECTIONS

POWER UNIT CONNECTIONS

See Figure 9-2 for an illustration of connections.

⚠WARNING *Accidental starting, sparks and high voltage can cause severe personal injury or death. Do not connect to the Coach Batteries or to Shore Power until so instructed in “Appendix C. Installation Review and Startup.”*

Battery Cables

Refer to Table 9-4 for the minimum gauge required for the Power Unit battery cables, as it depends on total cable length (round trip).

TABLE 9-4. MINIMUM BATTERY CABLE GAUGE

Round Trip Cable Length Feet (Meters)	Minimum Gauge
25 (7.6)	2 AWG
40 (12.2)	1/0 AWG
60 (18.3)	3/0 AWG

If the coach chassis is used for the negative (–) side of the circuit, the cable lugs must bolt to the same chassis rail to avoid the potentially high resistance of riveted or bolted joints and small cross members. For good electrical connections, remove the paint on the chassis frame under the cable lugs.

Power Unit Grounding Terminal

The negative (–) battery cable terminal is also the grounding terminal for the Power Unit. Use a

No. 8 AWG or heavier gauge cable for grounding to the coach chassis. The grounding cable must have the same gauge as the battery cables if it also carries cranking current.

Note: The Power Unit’s mounting bolts are not considered adequate means for bonding the Power Unit to the coach frame, either for the purpose of carrying cranking currents or for complying with grounding requirements.

Cable Terminals

Use 5/16 inch ring cable lugs at the Power Unit, 3/8 inch ring cable lugs at the Shunt/Fuse Block, and appropriately sized ring cable lugs at the batteries.

Connections

Route the battery cables and connect the Power Unit positive (+) cable to the Shunt/Fuse **LOAD** terminal. Do not connect the negative (–) cable at this time.

Note: Connect the DC Load circuit cable at the same time to the Shunt/Fuse **LOAD** terminal, stacking the ring terminals back-to-back. See **DC LOAD CONNECTIONS AND DISCONNECT SWITCH** (p. 9-6).

Torque the terminal nuts in accordance with Table 9-1.

Secure terminal covers when all connections have been made.



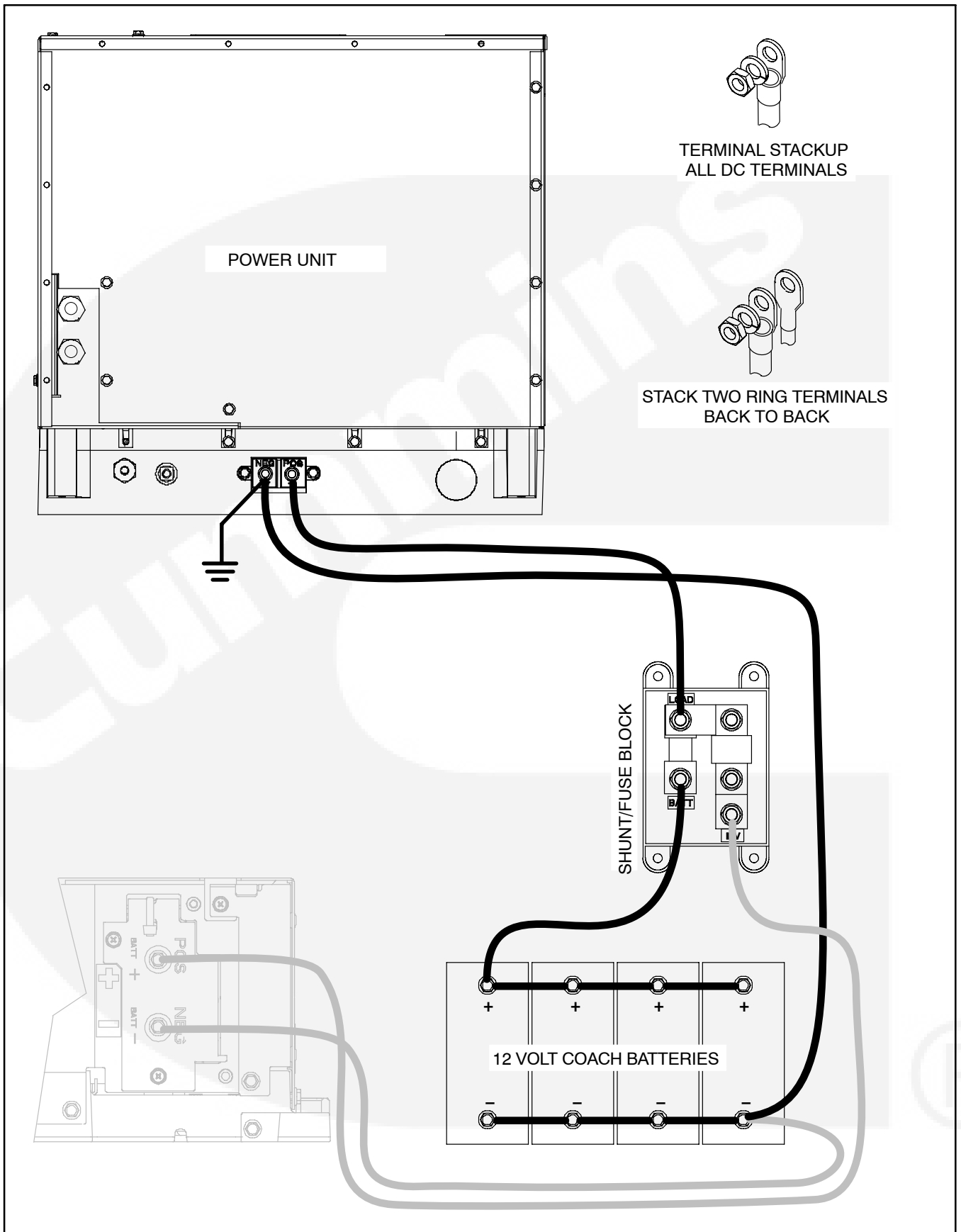

FIGURE 9-2. BATTERY CONNECTIONS

DC LOAD CONNECTIONS AND DISCONNECT SWITCH

See Figure 9-3 for an illustration of connections.

⚠WARNING *Accidental starting, sparks and high voltage can cause severe personal injury or death. Do not connect to the Coach Batteries or to Shore Power until so instructed in “Appendix C. Installation Review and Startup.”*

Connections

Route the cable from the DC Coach Disconnect

Switch to the Shunt/Fuse **LOAD** terminal and use a 3/8 inch ring cable lug at the Shunt/Fuse Block.

Note: Connect the Power Unit cable at the same time to the Shunt/Fuse **LOAD** terminal, stacking the ring terminals back-to-back. See **POWER UNIT CONNECTIONS** (p. 9-4).

Torque the shunt terminal nut in accordance with Table 9-1.

Secure terminal covers when all connections have been made.

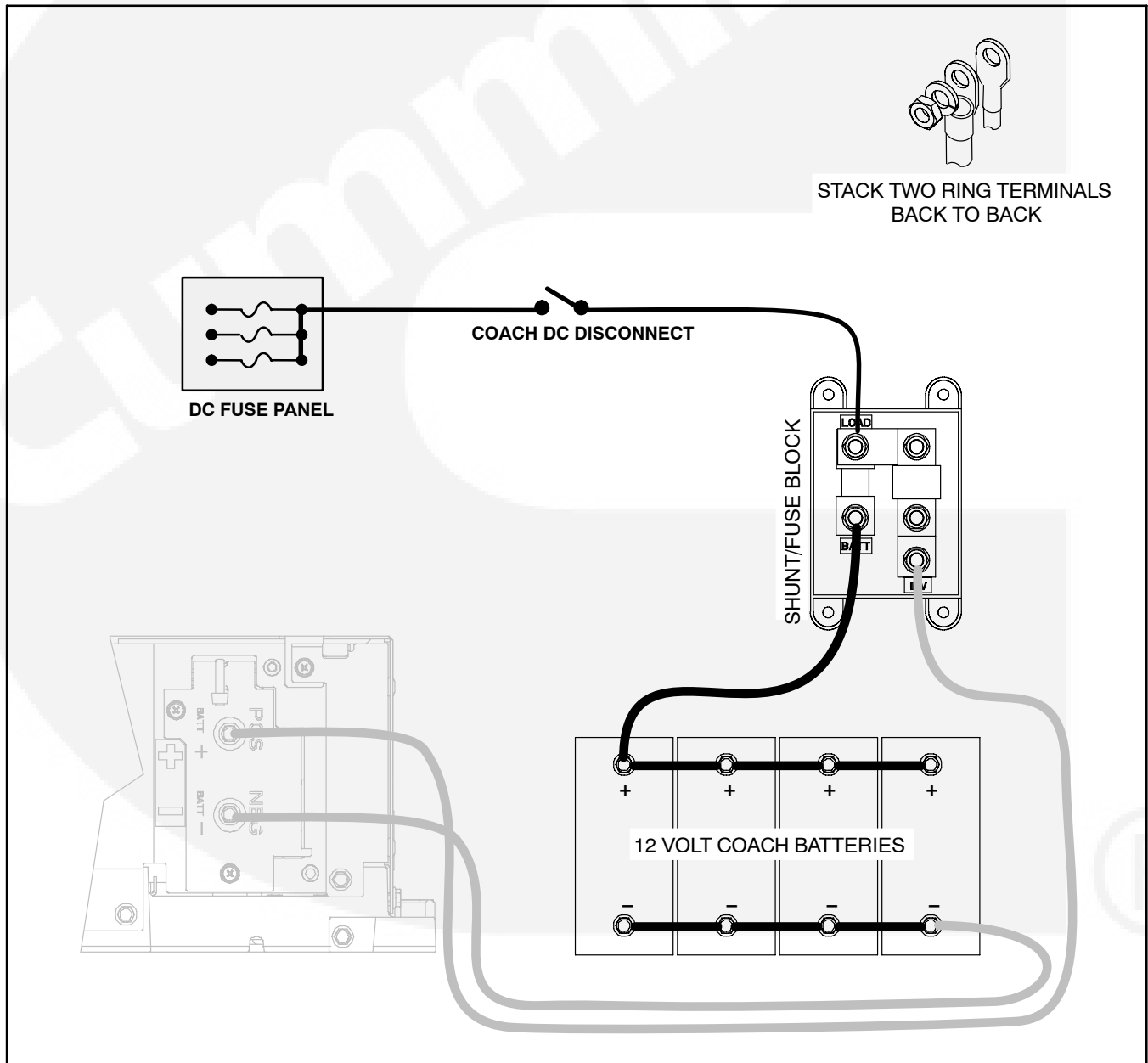

FIGURE 9-3. TYPICAL COACH DC DISCONNECT SWITCH AND BATTERY SAVER SIGNAL CONNECTIONS

10. Installation Review and Startup

INSTALLATION REVIEW

⚠WARNING *Unexpected starting of the Power Unit or connection to Shore Power during installation or service can lead to severe personal injury or death. Until ready to start up the Hybrid Power System, make sure to:*

Push the Power Unit circuit breaker OFF and disconnect the 10-Pin and 4-Pin remote control connectors and battery cables from the Power Unit. Insulate the end of the positive (+) battery cable to keep it from touching chassis ground.

Turn the Coach DC Disconnect Switch to its DISCONNECT position (to power down the Hybrid Power System).

Disconnect Shore Power.

Review the following items for proper installation. Make necessary repairs and reconnections before starting up the Hybrid Power System (p. 10-3).

Power Unit Location and Mounting

- [] The control panel is accessible for starting and stopping the Power Unit, resetting the circuit breakers and adding oil and coolant.
- [] All specified clearances have been provided.
- [] The air inlet and outlet openings are free of obstructions.
- [] The bottom access door swings all the way open for fuel and oil filter replacement.
- [] Access for draining oil and coolant is not obstructed.
- [] The air inlet is protected from direct road splash.
- [] The Power Unit clears the ground by at least 12 inches (305 mm).
- [] The Power Unit is securely bolted in place.
- [] The Power Unit is isolated from the interior of the coach by approved vapor and fire resistant materials.

- [] The Power Unit is located or shielded such that air conditioner condensate will not drip on the Power Unit.
- [] All tailpipe connections are tight and all hangers and support straps are secure.
- [] The tailpipe terminates at least 1 inch (25 mm) beyond the perimeter of the vehicle and at least 6 inches (153 mm) away from any opening into the vehicle.
- [] The tailpipe is not terminated under a slide-out room or near a fuel fill opening.
- [] The tailpipe is routed such that it is not likely to be struck while the coach is moving.
- [] Fuel lines have been secured at sufficient intervals to prevent chaffing and contact with sharp edges, electrical wiring and hot exhaust parts.

Inverter/Charger and Transfer Switch Location and Mounting

- [] The Inverter/Charger and Transfer Switch have been securely mounted in their proper orientations in dry, cool and adequately vented enclosures. The Inverter/Charger is properly grounded to the coach chassis.
- [] The Inverter/Charger coolant hoses have been routed, shielded, protected and secured such that they will not be kinked, cut, abraded, exposed to hot surfaces or damaged by road debris.

AC Connections

- [] The Transfer Switch is connected to the Shore Power Cord through a 60 Amp Class RK1 or K5 fuse in each line (L1 and L2).
- [] The coach has a Main AC distribution panel and a 30 amp sub-panel.
- [] A 30 amp branch circuit in the Main Coach AC Panel is provided for connection to the Inverter/Charger for Shore Power battery charging and pass-through power to the AC sub-panel.
- [] All AC wiring has been routed and secured away from sharp edges, fuel lines and exhaust pipes and is fastened with properly sized strain reliefs.

- [] All openings into the vehicle for wiring to pass through are sealed to keep out engine exhaust. AC conduit connectors are sealed inside and outside.
- [] All AC terminals have been torqued as specified and the covers are in place and secure.

Coach Batteries and Cables

- [] The Coach Batteries are mounted in a properly ventilated enclosure isolated from spark-producing equipment and located so as not to drip acid on other equipment.
- [] The Shunt/Fuse Block is located close enough to the positive (+) battery terminal that the cable does not exceed 18 inches (45 cm) in length. The battery cable is connected to the Shunt/Fuse **BATT** terminal. It is the only wire or cable to be connected to the positive (+) terminals of the Coach Battery bank. **Do not connect to the batteries at this time. The proper connection sequence must be followed during startup.**
- [] The Inverter/Charger's positive (+) cable is connected to the Shunt/Fuse **INV** terminal. The other end is insulated to keep it from touching chassis ground before it is connected. **Do not connect to the Inverter/Charger at this time. The proper connection sequence must be followed during startup.**
- [] A Coach DC Disconnect Switch has been installed and is connected to the Shunt/Fuse **LOAD** terminal. All coach DC loads are connected to pass through the Shunt/Fuse **LOAD** terminal.
- [] The Power Unit's positive (+) battery cable is connected to the Shunt/Fuse **LOAD** terminal. The other end is insulated to keep it from touching chassis ground before it is connected.

- [] The negative [-] terminal of the Coach Batteries is ready to be properly grounded to the vehicle chassis.
- [] All DC cables meet gauge and length specifications and are properly terminated with ring cable lugs.
- [] All DC cables have been routed and secured away from sharp edges, fuel lines and exhaust pipes and are accessible for replacement.

Communications Cables

- [] The Operator Panel is properly mounted and connected to Transfer Switch connector **J5**.
- [] The AUTO safety input signal is connected to Transfer Switch connector **J4**.
- [] The Load demand input signal is connected to Transfer Switch connector **J4**.
- [] Transfer Switch connector **J2** is connected to Inverter/Charger connector **J13**.
- [] The wakeup signal from the load side of the Coach DC Disconnect Switch is connected to Inverter/Charger connector **J15**.
- [] The Shunt sensor lead harness is connected to Inverter/Charger connector **J24**.
- [] The battery temperature sensor is bolted to an inter-battery positive (+) terminal in the Coach Battery bank and its lead is connected to Inverter/Charger connector **J11**.
- [] Power Unit connector **P2** is connected to Inverter/Charger connector **J12**.
- [] The remote control switch is connected to Power Unit connector **P8**.
- [] All communications cables have been routed and secured away from sharp edges, fuel lines and exhaust pipes.
- [] All openings into the vehicle for cables to pass through are sealed to keep out engine exhaust.



STARTUP

Inverter/Charger Battery Connections

Observe this **Connect Sequence**:

1. Connect the positive (+) cable at the Coach Batteries and then the positive (+) cables at the Power Unit and Inverter/Charger.
2. Connect the negative (-) cables at the Coach Batteries and then at the Power Unit and Inverter/Charger.
3. Torque all terminals as specified and secure the protective covers.

Pre-Start Checks

⚠WARNING ***EXHAUST GAS IS DEADLY! Do not operate the Hybrid Power System in Generator Mode when the Coach is indoors unless there is ample fresh air ventilation.***

Refer to the Operator's Manual and perform the maintenance and pre-start checks as instructed. The Power Unit is shipped from the factory with the proper levels of engine oil and coolant.

Fill and prime the Inverter/Charger cooling circuit as instructed.

Turn the Power Unit and AC Distribution Panel (Main and Sub) AC circuit breakers ON.

Wake the Hybrid Power System by turning the Coach DC Disconnect switch to it Connect position. The green lights on the Transfer Switch and Inverter/Charger should start flashing.

Hybrid Power System Set-Up

Push any button to turn on the Operator Panel display screen.

On first power up the Hybrid Power System checks whether the Safety and Load Demand signal types and Charger Line have been configured. If they have not, the "Service:Inputs" screen pops up (p. A-20). Enter the correct device or type in each field. (If you press Back the setup is aborted until the next time the display is powered up.)

Next, the Hybrid Power System checks whether Battery Capacity has been configured. If it has not, the "Service:Battery" screen pops up (p. A-21). Enter the correct value. (If you press Back the setup is aborted until the next time the display is powered up.)

Test Inverter Mode Operation

Push MANUAL on the Operator Panel and TURN INVERTER ON (p. A-7).

Check for AC power by turning on lights, a microwave and other appliances.

Test Shore Power Operation (50amp)

Connect Shore Power.

Check for power by turning on lights, an air conditioner and other appliances.

Check Battery Charger Line

When the charger is charging, identify which AC Line is feeding the Charger (Line 1 or 2). Go the "Service: Inputs" screen (p. A-20) and change the value if not correct.

Disconnect Shore Power.



Test Power Unit Operation

Push MANUAL on the Operator Panel and TURN GENSET ON (p. A-7). After the Power Unit starts, wait for the transfer switch to close (30 seconds).

Check for power by turning on lights, an air conditioner and other appliances.

Check for unusual noises and for fuel, coolant, oil and exhaust leaks and make necessary repairs.

Push MANUAL on the Operator Panel and TURN GENSET OFF (p. A-7).

Press and hold START on the Power Unit control panel until the engine starts. Touch STOP to stop the Power Unit. Start and Stop the Power Unit also from the remote control switch.

Test AUTO

Push AUTO on the Operator Panel (p. A-1).

Cycle the Safety Signal by turning it On and Off to verify the signal.

Push OK.

Turn on an air conditioner to check whether the Hybrid Power System will respond to the power demand.

Hot Air Recirculation Test

A representative installation of the Hybrid Power System must be tested to determine that neither Power Unit nor Inverter/Charger will overheat due to recirculation of hot air. Refer to *Appendix C. Hot Air Recirculation Test*.



Appendix A. Operator Panel

ABOUT THE OPERATOR PANEL

Use the Operator Panel (Figure A-1) to control and monitor the Hybrid Power System. The panel has eight function buttons, a digital display screen and six status lights.

Function Buttons

Press **Auto** to confirm and enable AUTO operation (p. A-3).

Press **Manual** for manual control of Inverter Mode and/or Generator Mode (p. A-7).

Press **Menu** to go to the Menu screens (p. A-8).

Press **Clock** to reset the current time (p. A-6).

Press the **Up** or **Down** arrow button to select items on a menu screen or increment the values.

Press **Back** to return to the previous screen.

Press **OK** to accept the selected value or enable the action.

Display Screen

Press any function button to turn on the display screen. See Page A-18 to adjust screen brightness, contrast and duration.

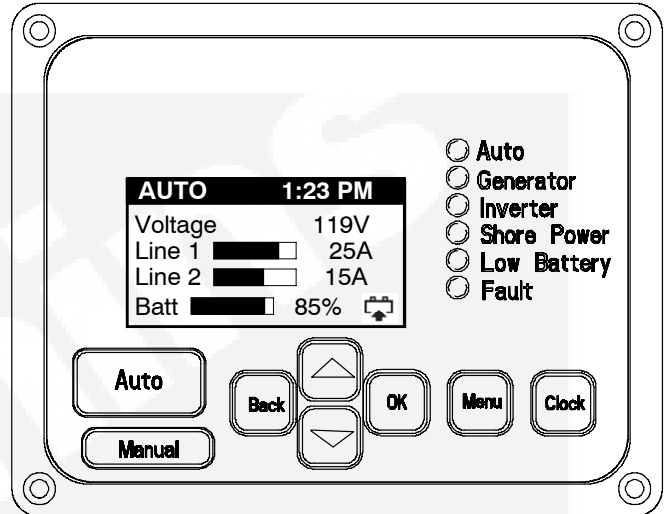

FIGURE A-1. OPERATOR PANEL

Status Lights

TABLE A-1. STATUS LIGHTS

LED Name	Color	Status Indicated
Auto	Green	AUTO is enabled to supply power in Generator, Inverter or Shore Power Mode
Generator	Green	Power is being supplied in Generator Mode.
Inverter	Green	Power is being supplied in Inverter Mode.
Shore Power	Green	Power is being supplied in Shore Power Mode.
Low Battery	Yellow	Coach Battery Charge is getting low.
Fault	Red	A Hybrid Power System fault has occurred.

HOME SCREEN

Press **Menu** one or more times to go to the Home Screen (Figure A-2). The Home Screen displays:

- Whether the Hybrid Power System is in Auto, Auto when Quiet Time (QT) is in effect, or Manual
- The current time
- The AC Voltage and Amperage in each line (Line 1, Line 2) (The bar graphs illustrate how much of the available current is being used in each line.)
- The percentage of useable battery charge remaining, also illustrated by the bar graph
- Whether the batteries are being charged or discharged, as illustrated by the battery icon with an up arrow (charging) or down arrow (discharging)

Note: The Status Light indicates which Mode is providing power: Generator Mode, Inverter Mode or Shore Power Mode.

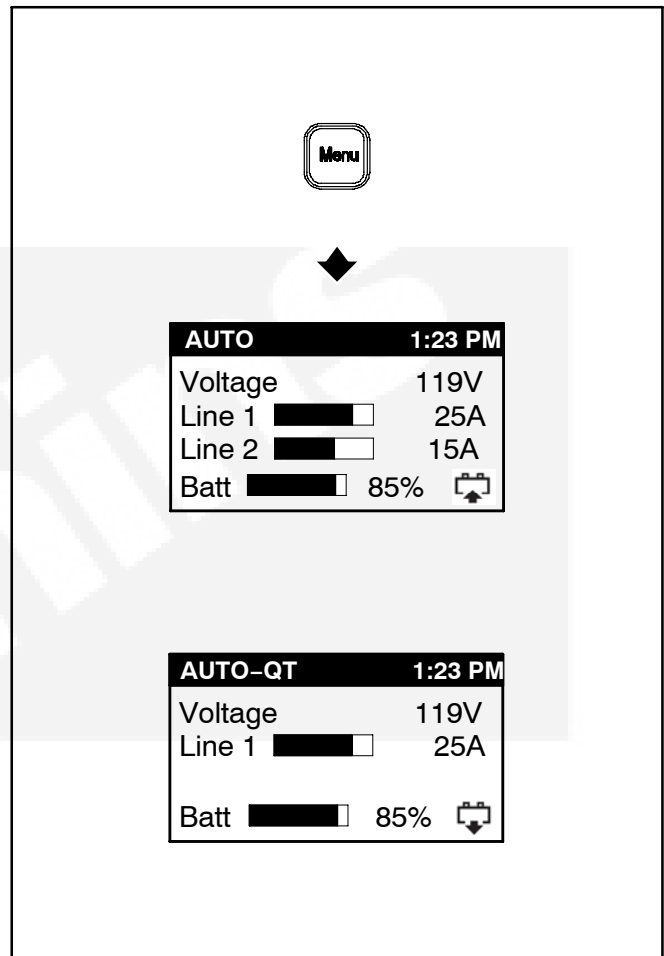

FIGURE A-2. TYPICAL HOME SCREENS



AUTO BUTTON

⚠WARNING **ENGINE EXHAUST IS DEADLY.** Engine exhaust gases include **CARBON MONOXIDE (CO)**, an odorless, colorless, poisonous gas that can cause severe personal injury or death. Symptoms of CO poisoning include:

- Dizziness, Headache or Throbbing Temples
- Weakness or Muscular Twitching
- Sleepiness or Confusion
- Nausea or Vomiting

IF YOU OR ANYONE ELSE EXPERIENCES ANY OF THESE SYMPTOMS, GET OUT INTO FRESH AIR IMMEDIATELY. Get advice from 911, poison control or a medical center. Do not enable AUTO or start Generator Mode until the exhaust system has been repaired. Exhaust system installation must be in accordance with the Hybrid Power System Installation Manual.

Do not enable AUTO or start Generator Mode be-

fore going to sleep unless the coach has working CO detectors.

Do not enable AUTO or start Generator Mode unless the coach is out in fresh, open air.

Disable AUTO and stop Generator Mode when parking the coach in a garage or other confined space.

⚠WARNING **Disable AUTO and stop Generator Mode before fueling the coach to prevent ignition of flammable vapors.**

The Hybrid Power System is intended for AUTO operation in daily use. It should be noted that AUTO is disabled each time you park or move the coach. This gives YOU the opportunity to confirm that AUTO operation is safe under the conditions.

Note: See Page A-27 if either of these two prompts appear: “Auto Mode Expires in (5, 4, 3, 2, or 1) days” or “Safety Input Expired.”



To Enable AUTO

Confirm that it is safe to operate in Generator Mode and press **Auto**. Note the Quiet Times displayed on the CONFIRM AUTO screen (Figure A-3).

If the Quiet Times are okay, press **OK** to enable AUTO.

If the Quiet Times need be reset, see Page A-5 to reset the Quiet Times before enabling AUTO.

AUTO Operation

When AUTO is enabled, the Auto and Inverter lights come on and you will have power available right away for most coach appliances, lights and power outlets.

From time to time the Inverter light will go out and the Generator light will come on, indicating that AUTO has switched to Generator Mode to recharge the coach batteries when charge drops to the preset START State of Charge (p. A-16) or to power the air conditioners when AUTO receives a power demand signal.

You should hear the Power Unit engine crank, start and run when AUTO switches to Generator Mode. AUTO will make up to three attempts to start the engine, allowing 60 second rest periods.

AUTO switches back to Inverter Mode 15 minutes after the air conditioner demand signal has stopped, unless it is recharging the batteries.

If Quiet Time has been enabled, AUTO will switch to Generator Mode as far ahead of time as necessary (could be several hours) to fully charge the batteries for the upcoming Quiet Time.

If AUTO is enabled while Generator Mode is under manual control, AUTO will turn off Generator Mode in 15 minutes unless the coach batteries are being charged or the air conditioners are running.

If Generator Mode is on and you do not want to disrupt operation when turning the ignition key or releasing the brake to move the coach, first exit AUTO. To do this, press **Manual**, select EXIT AUTO MODE (Figure A-7) and press **OK**. Generator Mode will stay on while driving until manually turned OFF.

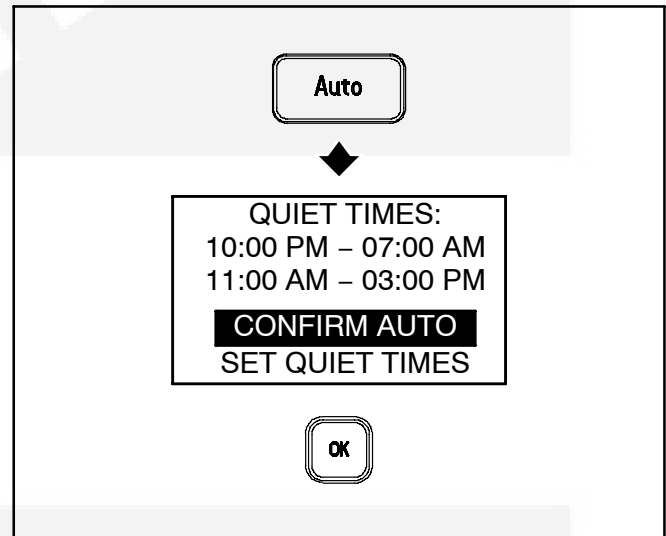

FIGURE A-3. ENABLE AUTO—QUIET TIMES OKAY

To Set Quiet Times Before Enabling AUTO

Note: Reset Current Time (p. A-6) if the time zone has changed, otherwise the Quiet Times will occur an hour earlier or later than expected.

Two QUIET TIME periods can be set for each 24 hour period. The Quiet Time 1 default time period is 10:00 PM to 7:00 AM. Quiet Time 2 does not have a default time period.

Press **OK** with SET QUIET TIME selected.

Press **Up** or **Down** to select QUIET TIME 1.

Press **OK**.

Press **Up** or **Down** to toggle between ENABLE and DISABLE.

Press **OK** to accept ENABLE or DISABLE.

Press **Up** or **Down** to increment the Start and End times. Hold down the button for fast scroll. The time increment is 15 minutes.

Repeat the procedure for QUIET TIME 2.

Press **OK** to accept the settings and go back to the QUIET TIME screen.

Press **Up** or **Down** to select DONE.

Press **OK** to go back to CONFIRM AUTO screen.

Press **OK** to enable AUTO.

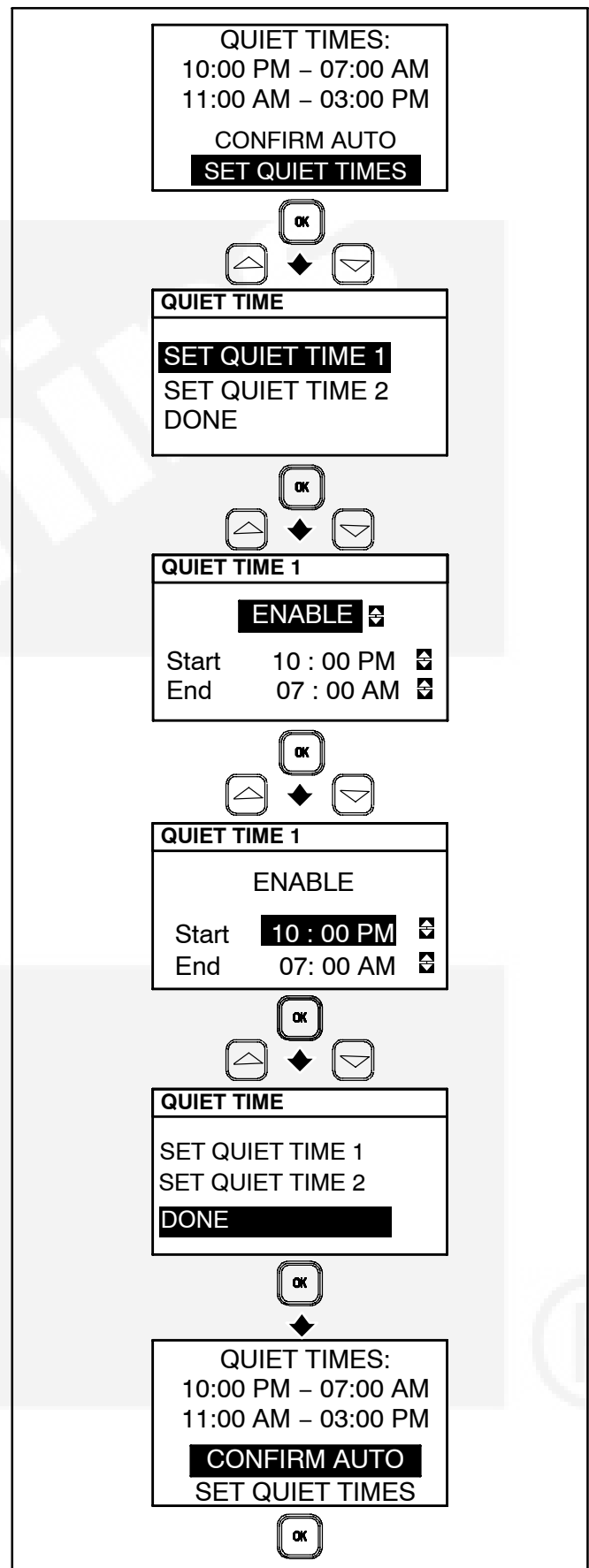

FIGURE A-4. ENABLE AUTO—RESET QUIET TIMES

CLOCK BUTTON

Set Current Time

Press **Clock**.

Press **Up** or **Down** to select SET CURRENT TIME.

Press **OK**.

Press **Up** or **Down** to increment the hour, minute and AM/PM. Hold down the button for fast scroll.

Press **OK** one or more times to accept the setting and go back to the home screen.

Set Quiet Times

If the Hybrid Power System is in AUTO, use the Clock button and select SET QUIET TIMES to get to the Quiet Time screen (p. A-5).

On the Quiet Time screen select DONE to accept the Quiet Time settings and press the OK button.

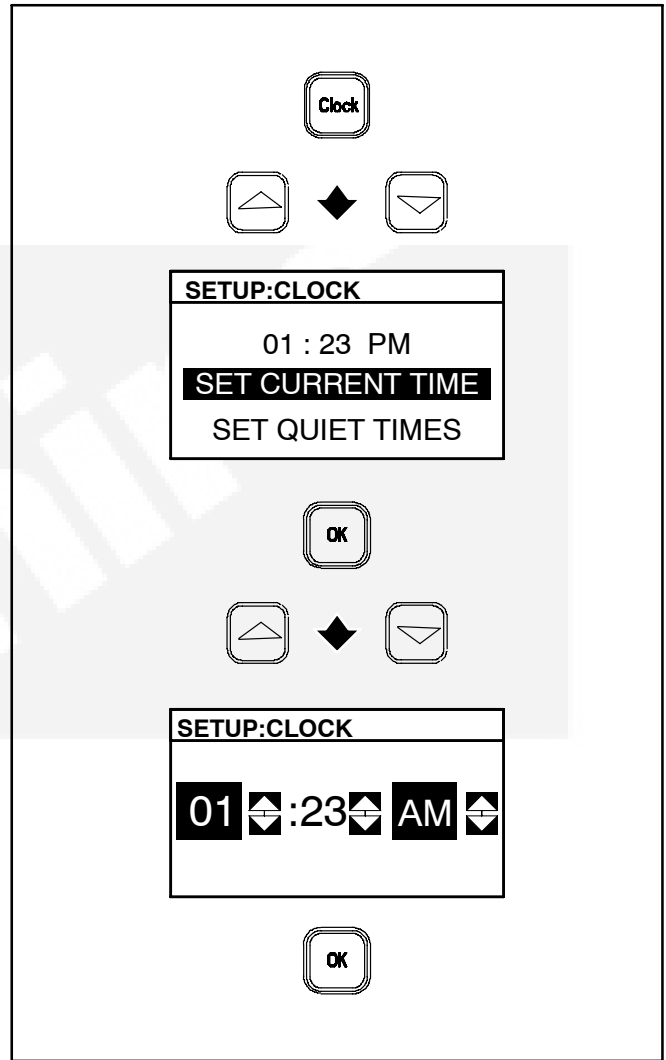

FIGURE A-5. CURRENT TIME SETUP

MANUAL BUTTON

Press **Manual**.

Press **Up** or **Down** to select the desired action.

Press **OK** to enable the action.

TURN ALL ON/OFF

TURN ALL ON if you want Inverter Mode to come on when you turn off Generator Mode.

TURN ALL OFF when it is necessary to save battery charge or fuel or perform maintenance.

TURN INVERTER ON/OFF

TURN INVERTER ON when neither Generator Mode nor Shore Power Mode is available.

TURN INVERTER OFF when it is necessary to save battery charge or perform maintenance.

TURN GENSET ON/OFF

Confirm that it is safe to operate in Generator Mode and TURN GENSET ON for manual control of Generator Mode. You will not hear or see any indication of the starting process for up to 15 seconds while the engine glow plugs pre-heat the combustion chambers.

The Generator light will come on after the Power Unit has warmed up for 30 seconds and you will have power available for to all coach appliances, lights, power outlets and air conditioners.

TURN GENSET OFF to stop Generator Mode and disable AUTO.

EXIT AUTO MODE

EXIT AUTO MODE if the Hybrid Power System is in Generator Mode and you do not want to disrupt operation when turning the ignition key or releasing the brake to move the coach. Generator Mode will stay on while driving until manually turned off.

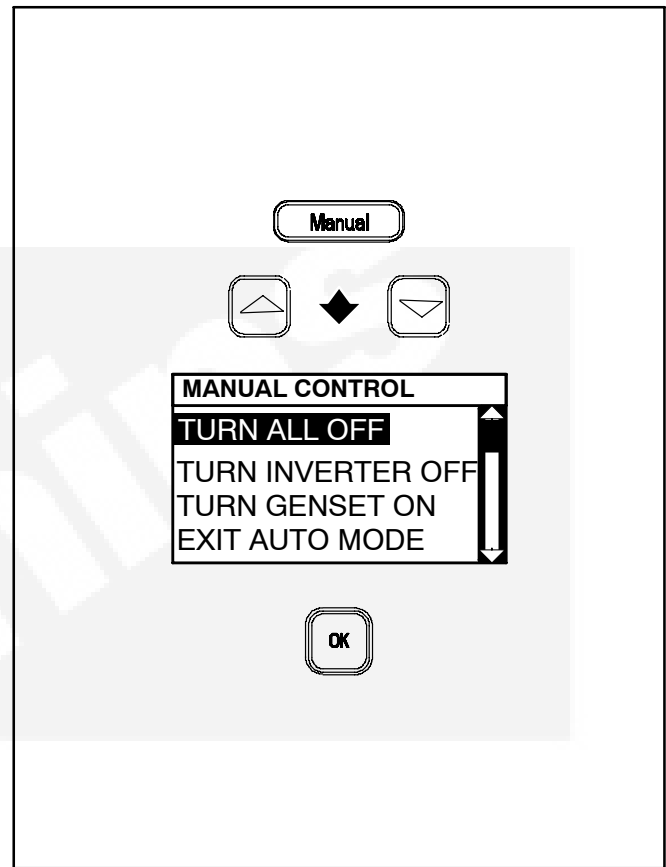

FIGURE A-6. MANUAL CONTROL SCREEN

STATUS MENU

Press **Menu** to enter the top level Menu. There are three menu levels:

- Status – Top level Menu
- Setup – Last Item in the Status Menu (p. A-15)
- Service – Last Item in the Setup Menu (p. A-19)

Press **Up** or **Down** to select one of the following from the Status Menu:

- BATT STATUS
- AUTO STATUS
- GEN STATUS
- INV STATUS
- SHORE STATUS
- FAULT INFO
- SETUP (SUB-MENU)

Press **OK** to accept the selection.

Press **Menu** one or more times to go back to the home screen.

See the following pages for details about each menu item.

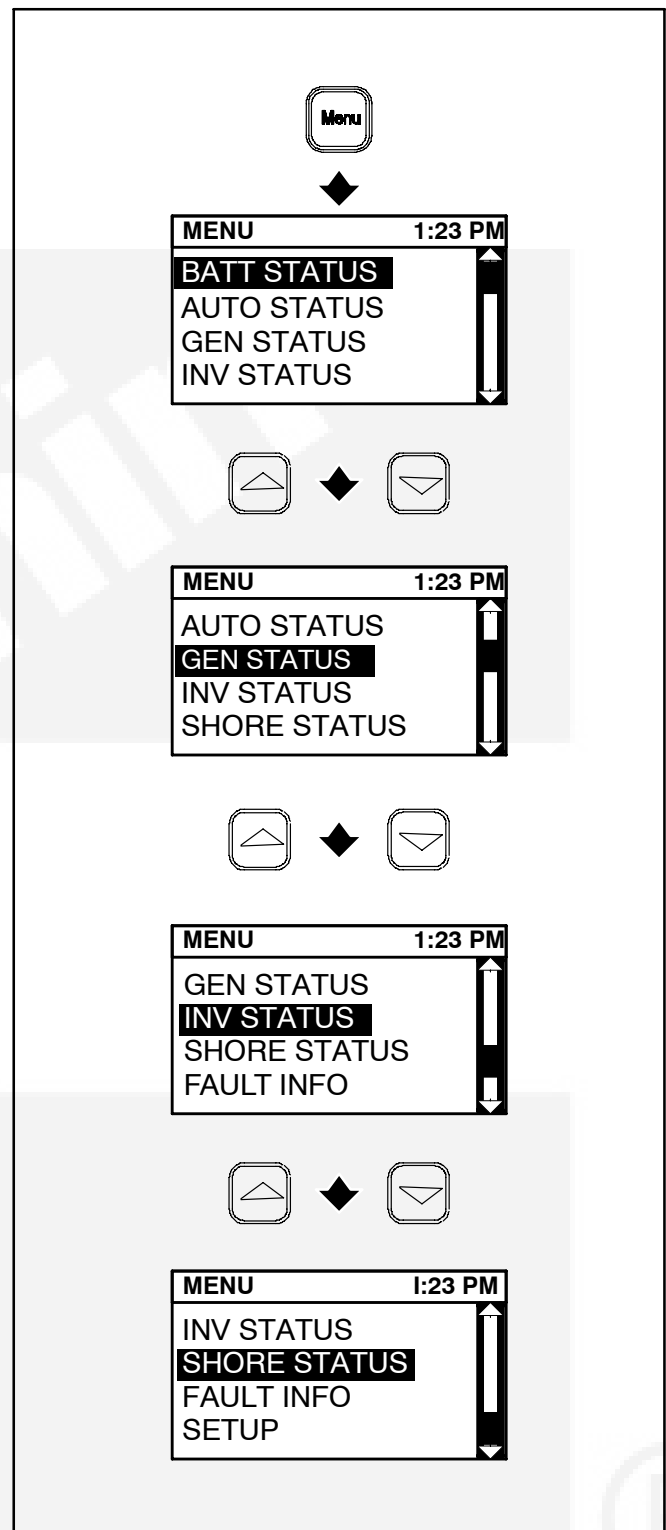

FIGURE A-7. STATUS MENU ITEMS

BATT STATUS

Press **Menu**.

Press **Up** or **Down** to select BATT STATUS.

Press **OK**. The BATTERY(DC) screen displays the following information:

- Battery voltage
- If the batteries are being charged, the DC current (amperage) they are “Charging At”
- If the batteries are being discharged, the DC current (amperage) they are “Discharging At”
- The percentage of useable battery charge remaining, as also illustrated by the bar graph.
- “Life Available” in hours if discharging, or “Charge Time” if charging

Battery Life Available indicates the number of hours remaining at current power usage in Inverter Mode. Life available is recalculated every 4 minutes on the basis of the average usage over that period. The battery State of Charge is calculated on the basis of the continuously tracked current to and from the Coach Batteries and on various other factors such as battery type, battery bank capacity and battery temperature.

Note: A full charge cycle is required after batteries have been reconnected to get an accurate Life Available indication.

Press **Menu** one or more times to go back to the home screen.

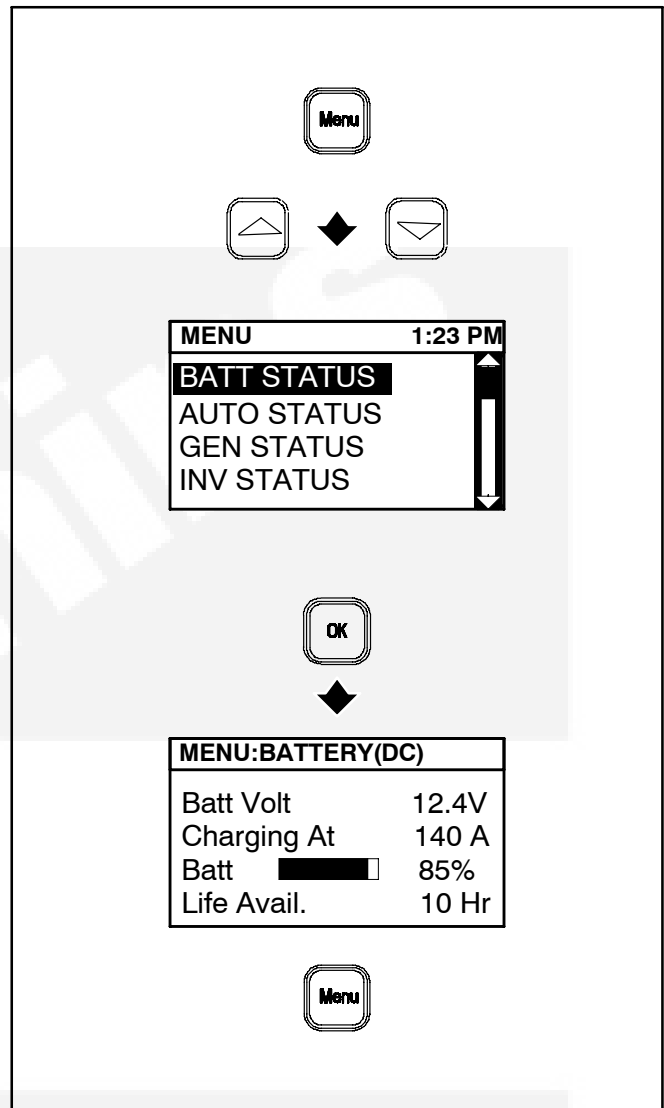

FIGURE A-8. BATTERY STATUS

AUTO STATUS

The purpose of this status screen is to let you know why AUTO is or is not in Generator Mode.

Press **Menu**.

Press **Up** or **Down** to select AUTO STATUS.

Press **OK**. The AUTO screen will display one of the following as Auto Status:

- Standby – There is no load demand or need for Generator Mode to charge the batteries.
- Quiet Time – Quiet Time is in effect. Generator Mode will not respond to load demand or low batteries.
- Disabled – Auto was disabled manually or by the safety signal when the coach was parked or moved.
- Low Battery – Generator Mode is on to re-charge low batteries.
- Battery Overload – Generator Mode came on during Inverting Mode due to battery overload.
- Load Demand – Generator Mode is responding to a load demand.

Note: AUTO switches from Generator Mode back to Inverter Mode 15 minutes after the air conditioner demand signal has stopped, unless it is recharging the batteries. This reduces the number of Power Unit starts and stops when there are cycling load demands, such as for air conditioning.

The “Days Left” field indicates the number of days left before the AUTO safety signal must be cycled. See Page A-27.

Press **Menu** one or more times to go back to the home screen.

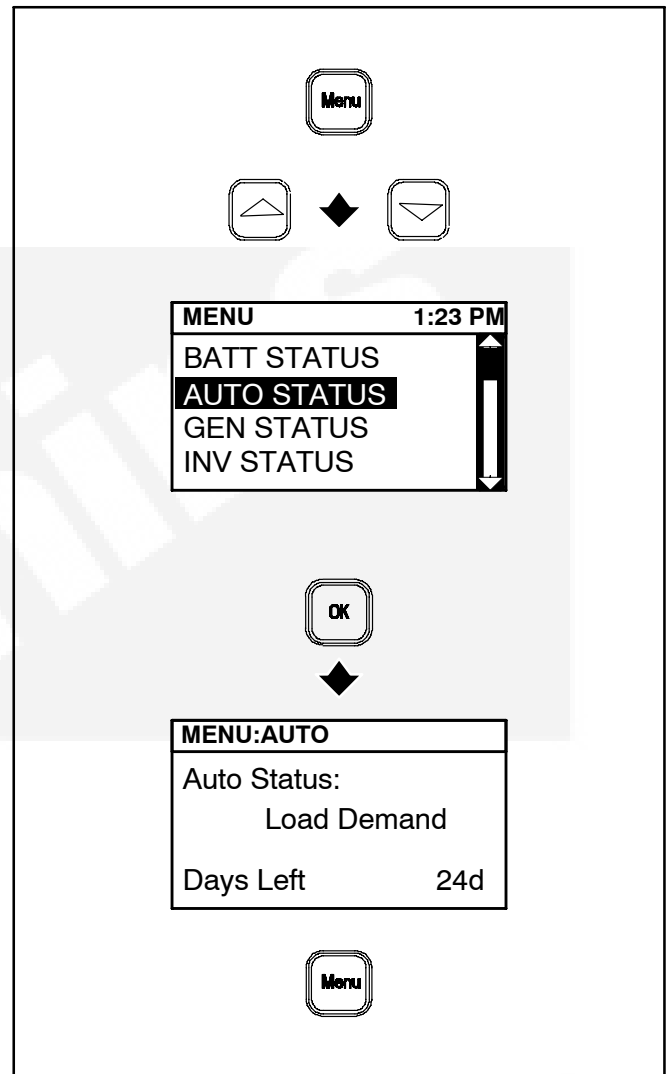

FIGURE A-9. AUTO STATUS

GEN STATUS

Press **Menu**.

Press **Up** or **Down** to select GEN STATUS.

Press **OK**. The GENSET screen displays the following information:

- Engine RPM (load dependent, ranging from 1400 to 2600 RPM)
- Engine coolant temperature
- Hours (total running time)
- Line 1 Voltage and Amperage (AC)
- Line 2 Voltage and Amperage (AC)

Press **Menu** one or more times to go back to the home screen.

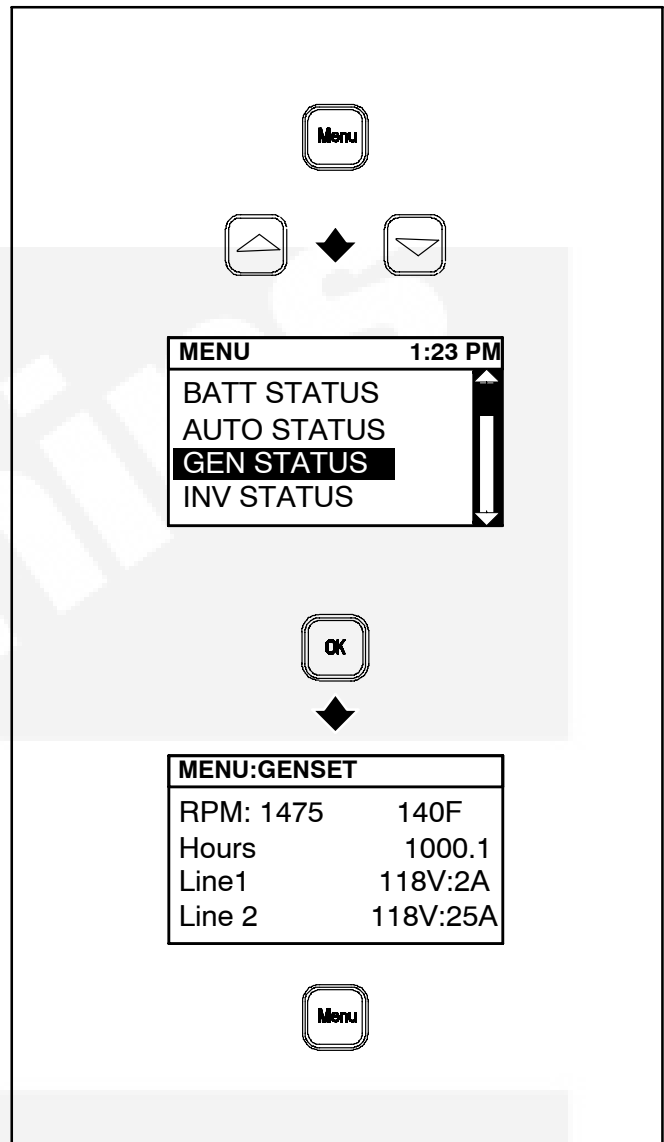

FIGURE A-10. GENSET STATUS

INV STATUS

Press **Menu**.

Press **Up** or **Down** to select INV STATUS.

Press **OK**.

The INVERTER screen indicates whether or not Inverter Mode has been turned on. See Page A-7. If Inverter is "ON," Inverter Mode will resume operation when shore power is disconnected or Generator Mode is turned off. Disable Inverter Mode if you do not want it to resume operation.

During Inverter Mode this screen shows the voltage and amperage of the Inverter/Charger output to the AC sub-distribution panel.

Press **Menu** one or more times to go back to the home screen.

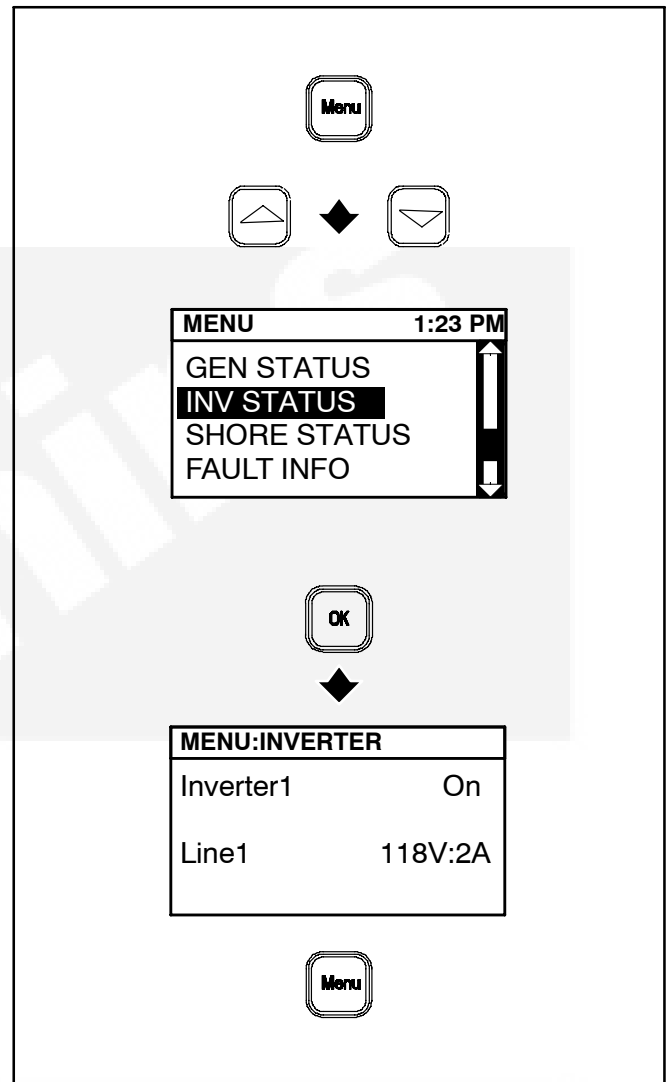

FIGURE A-11. INVERTER STATUS

SHORE STATUS

Press **Menu**.

Press **Up** or **Down** to select SHORE STATUS.

Press **OK**. The SHORE screen displays one of the following in the “Shore Quality” field:

- Good
- Not Detected
- Over Frequency
- Under Frequency
- Reverse Polarity
- High Voltage
- Low Voltage
- Loss of Neutral
- Loss of L1
- Loss of L2

See *Appendix D. Specifications* regarding acceptable shore power.

This screen also shows the voltage and amperage in each shore supply line (Line 1, Line 2).

Press **Menu** one or more times to go back to the home screen.

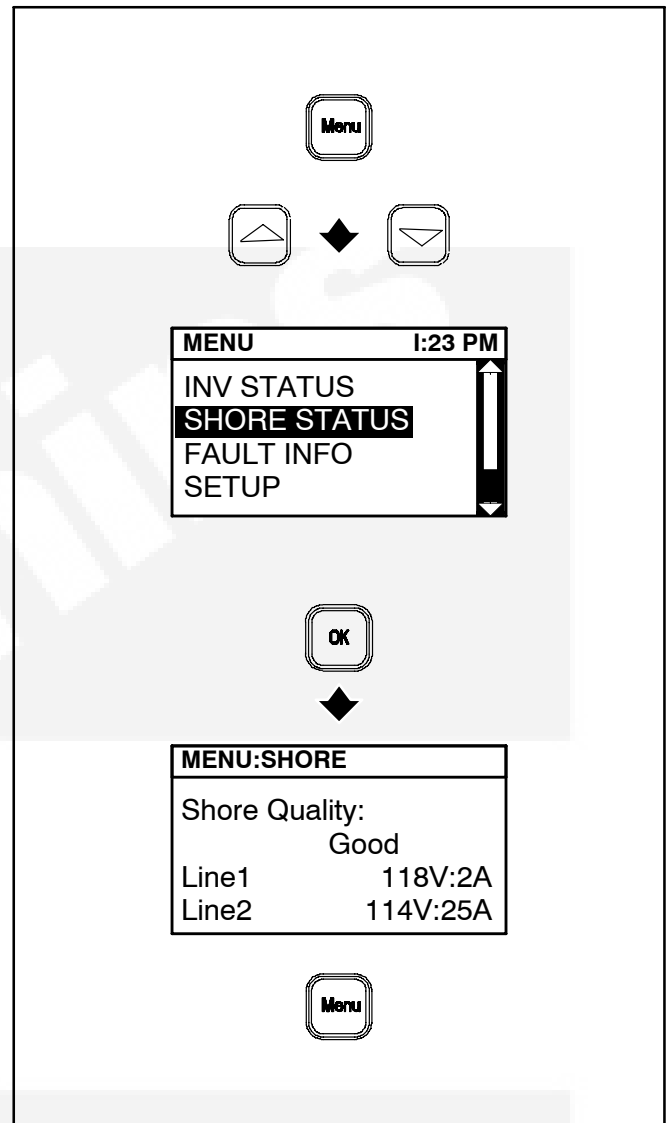

FIGURE A-12. SHORE STATUS



FAULT INFORMATION

Press **Menu**.

Press **Up** or **Down** to select FAULT INFO.

Press **OK**. The FAULT screen displays the following information on up to 15 of the most recent faults:

- The Fault Code Number
- A brief description of the fault
- The accumulated time in hours that the Hybrid Power System had been powered up when the fault occurred.

See *Troubleshooting Fault Codes* in the Service Manual.

Press **Up** or **Down** to scroll through the list of faults.

Press **Menu** one or more times to go back to the home screen.

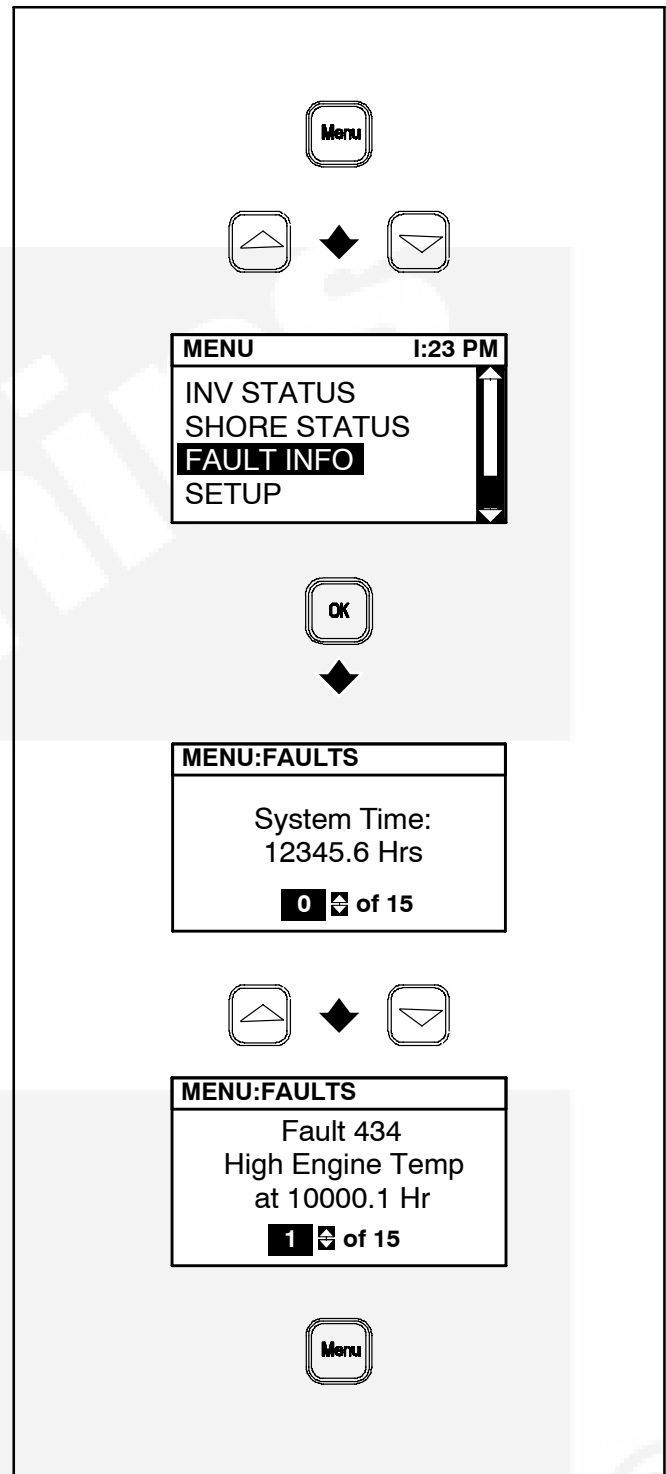

FIGURE A-13. FAULT INFORMATION

SETUP MENU

Selecting **SETUP** takes you to a second-level menu.

Press **Menu**.

Press **Up** or **Down** to select **SETUP**.

Press **OK**.

Press **Up** or **Down** to select one of the following from the **SETUP** sub-menu:

- **AUTO SETUP**
- **SHORE BREAKER**
- **SCREEN SETUP**
- **SERVICE** (Selecting **SERVICE** takes you to a third-level menu.)

Press **OK** to accept the selection. See the following pages for details about each menu item.

Or, press **Menu** one or more times to go back to the home screen.

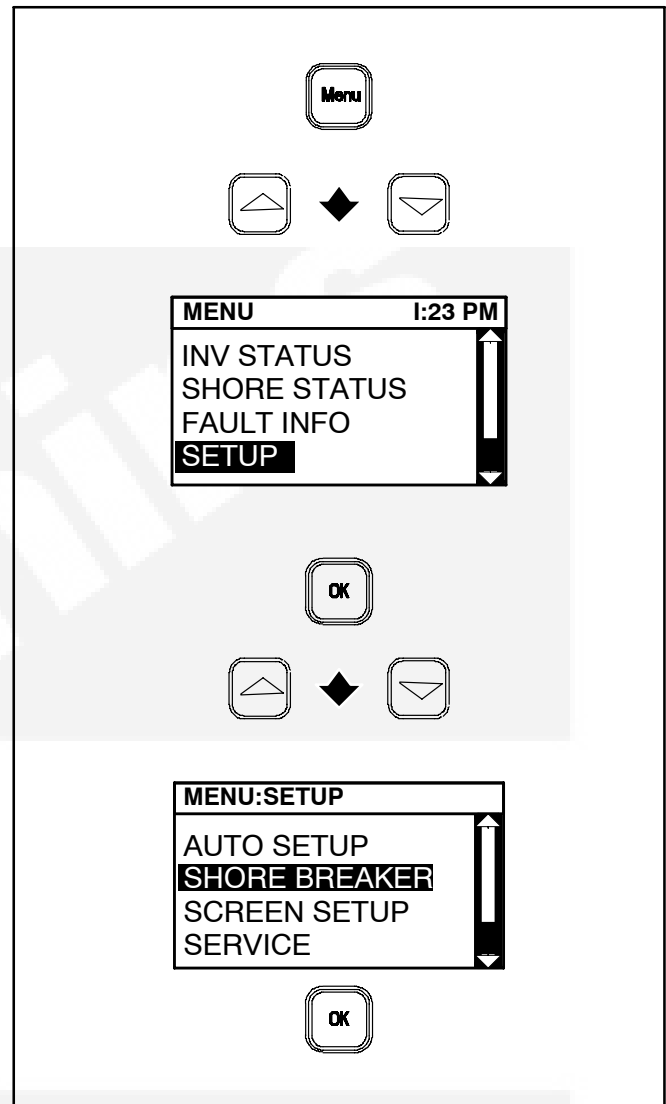

FIGURE A-14. SETUP MENU ITEMS

AUTO SETUP

This feature enables the user to set the minimum battery state of charge when Auto switches to Generator Mode to recharge the batteries and the maximum state of charge when it switches back to Inverter Mode.

Press **Menu**.

Press **Up** or **Down** to select SETUP.

Press **OK**.

Press **Up** or **Down** to select AUTO SETUP.

Press **OK**.

Press **Up** or **Down** to increment to the Start State of Charge at which to automatically start the Power Unit. Selections are: 40%, 50%, 60% and 70%.

Press **OK** to accept the Start value.

Press **Up** or **Down** to increment to the End State of Charge at which to automatically stop the Power Unit. Selections are 80%, 90% and 100%.

Press **OK** to accept the End value.

Press **OK** to accept the settings and go back to the home screen.

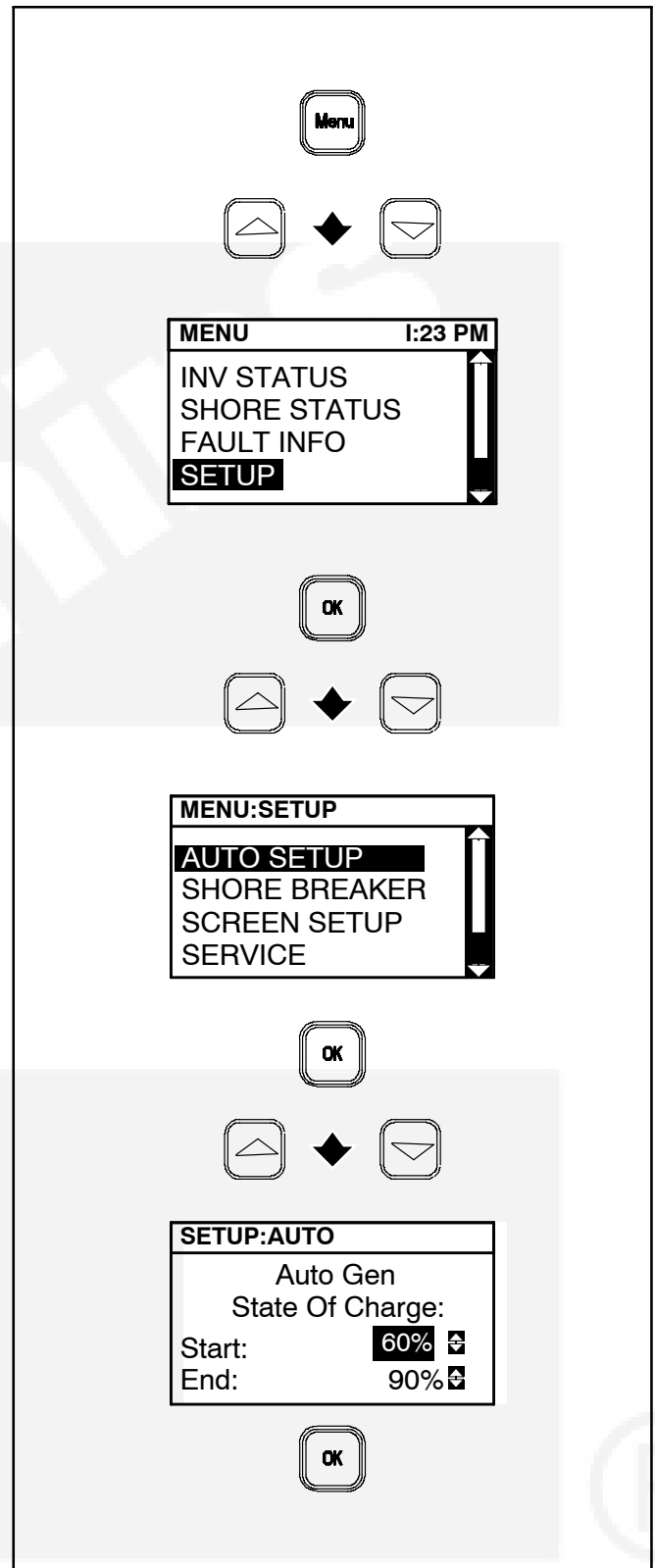

FIGURE A-15. AUTO SETUP

SHORE BREAKER

The Hybrid Power System senses whether the coach has been connected to a 50 amp shore power receptacle or to a 30 amp or smaller shore power receptacle through an adapter plug. See the SHORE POWER DETECTED prompt on Page A-25.

Because the Hybrid Power System can draw up to 21 amps of AC during heavy battery charging, shore power circuit breaker tripping at the pole could become a nuisance, especially if you connected the coach to a shore power service of less than 30 amps. By entering a smaller Breaker Size on the SHORE setup screen, maximum battery charging is reduced, resulting in less overall AC current draw through the shore power breaker on the pole. This could reduce the frequency of tripping.

Press **Menu**.

Press **Up** or **Down** to select SETUP.

Press **OK**.

Press **Up** or **Down** to select SHORE BREAKER.

Press **OK**.

Press **Up** or **Down** to increment the breaker size. Choices are 15A, 20A, 30A and 50A.

Note: The smaller the breaker size selected the longer it will take to recharge the Coach Batteries.

Press **OK** to accept the selection and go back to the home screen.

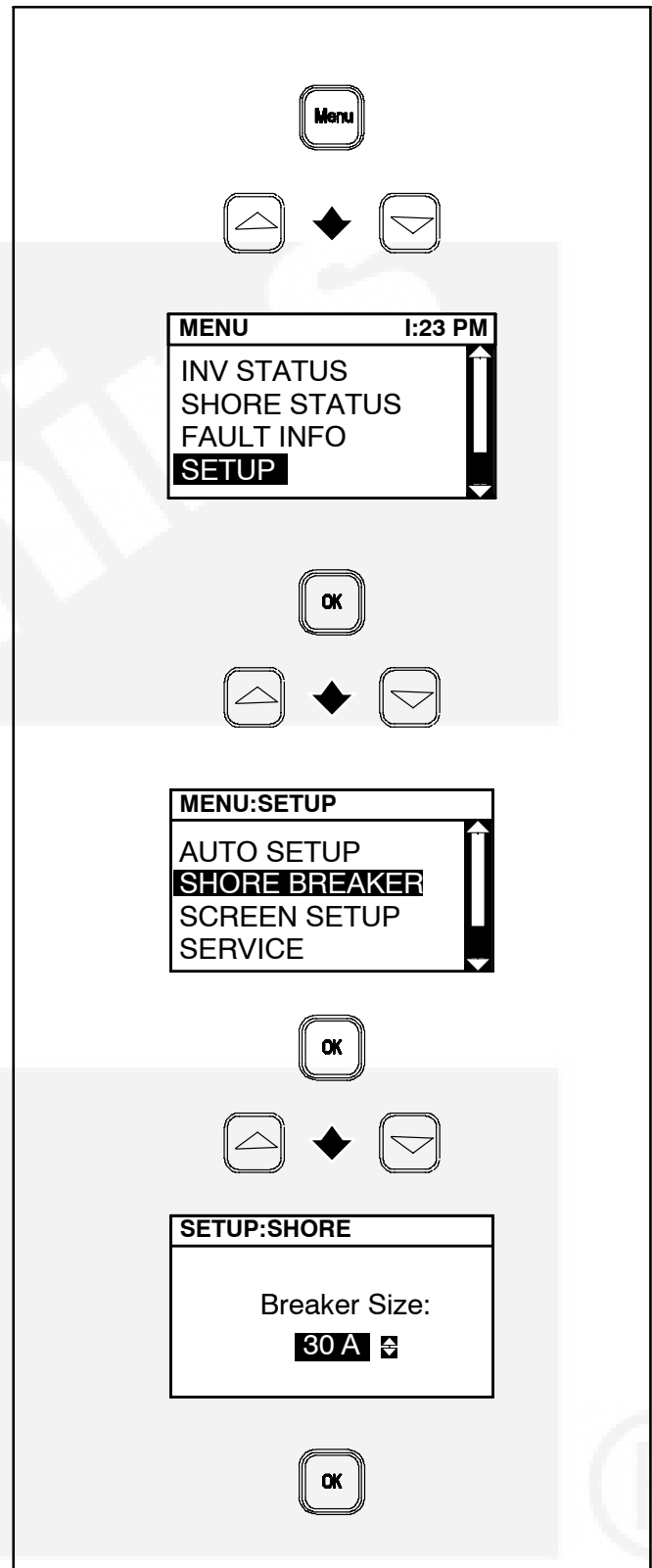

FIGURE A-16. SHORE BREAKER SETUP

SCREEN SETUP

This feature enables the user to set the Contrast and Brightness of the Operator Panel screen and the length of time the screen backlight stays on after the last touch.

Press **Menu**.

Press **Up** or **Down** to select SETUP.

Press **OK**.

Press **Up** or **Down** to select SCREEN SET UP.

Press **OK**.

Press **Up** or **Down** to select Contrast, Brightness or Timer.

Press **OK**.

Press **Up** or **Down** to change Contrast, Brightness or Timer.

Press **OK** to accept the settings and go back to the home screen.

The bar graphs indicate how much of the available Contrast or Brightness is being used.

The Backlight Timer can be set for 10 to 250 seconds, or turned off.

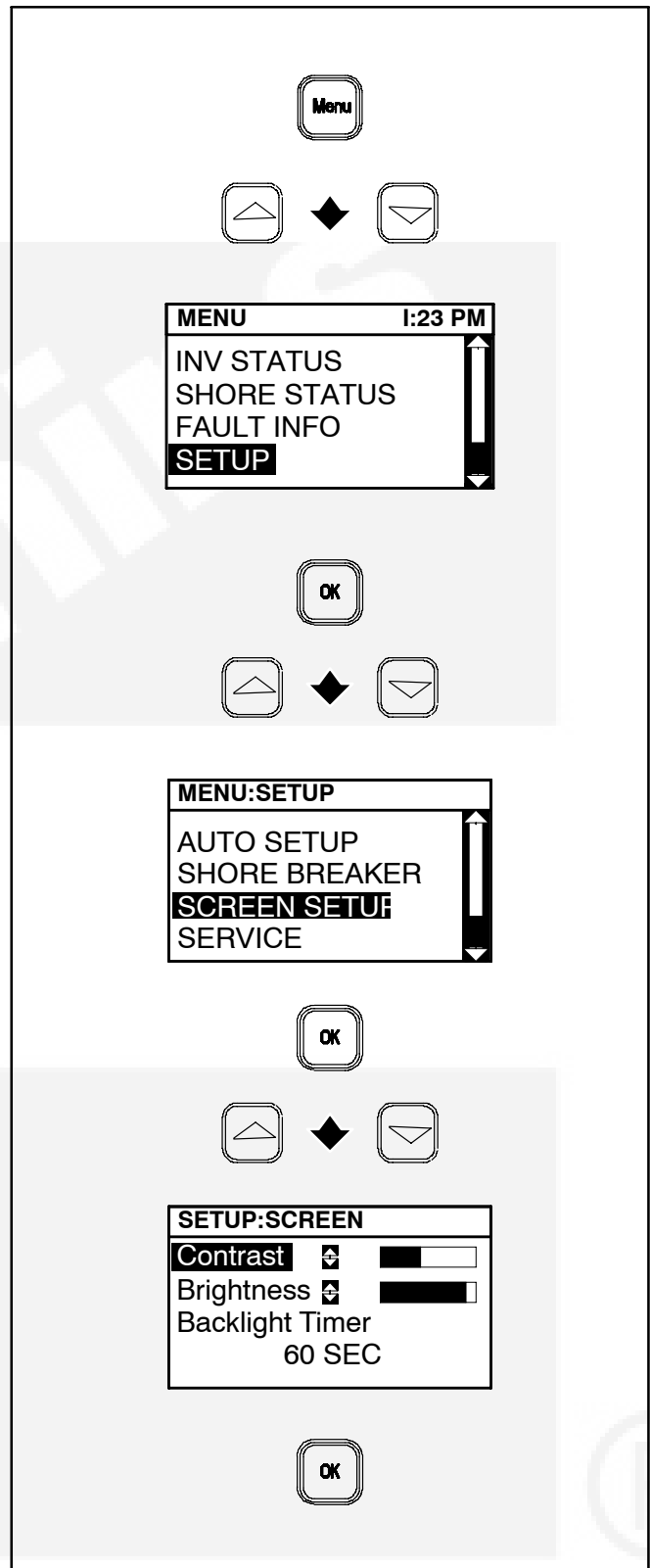

FIGURE A-17. SCREEN SETUP

SERVICE MENU

Selecting SERVICE takes you to a third-level menu. This is the third-level menu—procedures for those who are trained and experienced in the installation and service of Hybrid Power Systems.

Press **Menu**.

Press **Up** or **Down** to select the SETUP menu.

Press **OK**.

Press **Up** or **Down** to select the SERVICE menu.

Press **OK**.

Press **Up** or **Down** to select one of the following from the SERVICE menu:

- INPUT SETUP
- BATTERY SETUP
- EQUALIZE
- ABOUT

Press **OK** to accept the selection. See the following pages for details about each menu item.

Or, press **Menu** one or more times to go back to the home screen.

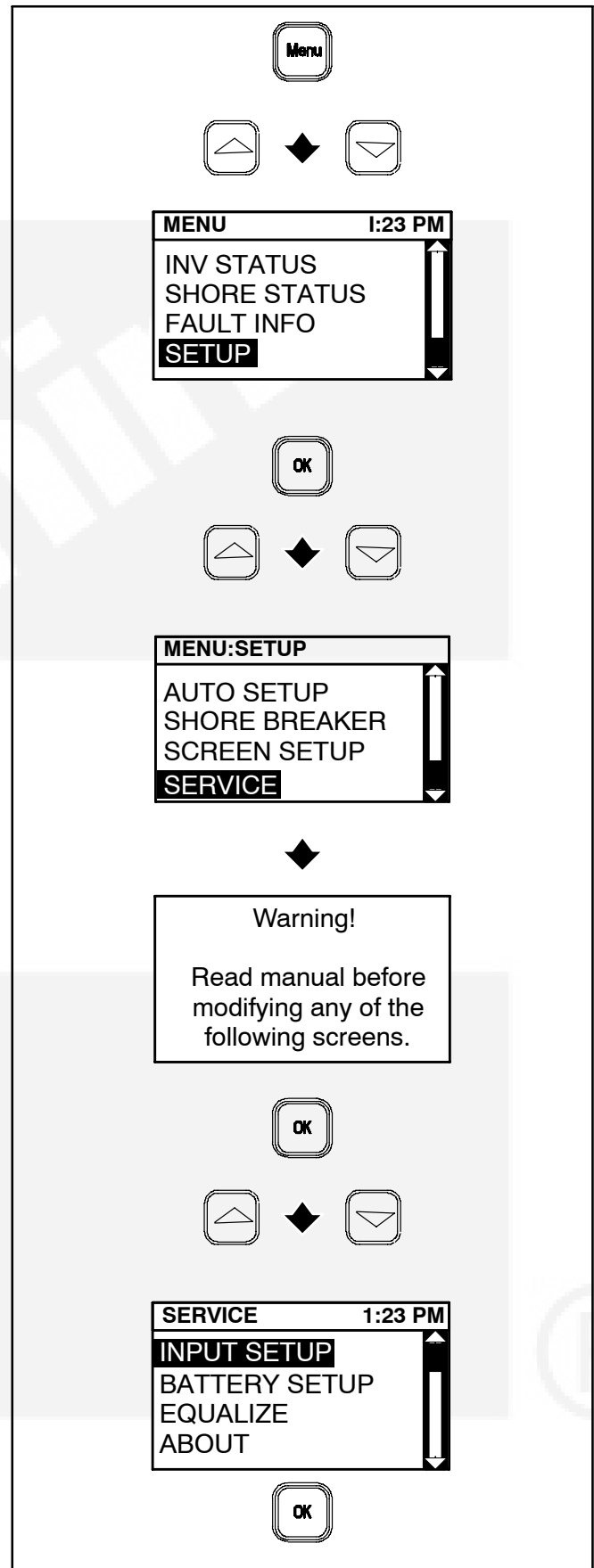

FIGURE A-18. SERVICE MENU ITEMS

INPUT SETUP

⚠ CAUTION *Entering wrong values for Input Setup can lead to unexpected operation.*

Upon completing the installation the installer must use the Operator Panel to configure three inputs to the Hybrid Power System.

Select INPUT SETUP on the SERVICE menu (Figure A-19).

Increment the values in the highlighted field by pressing the Up or Down button. Press OK to accept the value and go to the next field.

After all inputs have been configured, press the Menu or Back button one or more times to go back to the home screen.

Auto Safety Input

One of the following types of safety signal can be selected and should correspond to the one actually used so that the AUTO expiration screen will notify the user of the correct device that needs to be cycled:

- Ignition
- Brake
- Park

Note: The INPUT screen pops up with “NONE” in the Safety field on startup if the safety input has not been installed, without which the Hybrid Power System will not operate in AUTO.

Charger

Select LINE 1 or LINE 2 to correspond to the Shore Power line that supplies terminal block TB2 in the Inverter/Charger for battery charging and sub-panel

pass-through current. This is necessary so that the Hybrid Power System can determine the power line from which battery charging must be shed as power draw on that line nears capacity.

Load Demand Input

Select ACTIVE HIGH or ACTIVE LOW to correspond to the equipment load demand signal (p. 7-3).

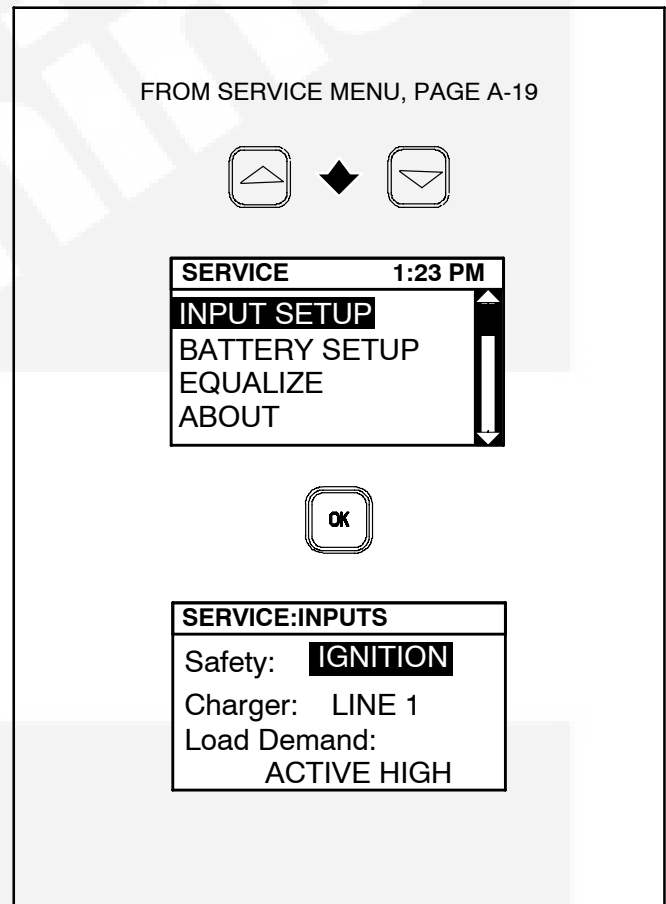

FIGURE A-19. INPUT SETUP SCREEN

BATTERY SETUP

Press **Up** or **Down** to select BATTERY SETUP on the SERVICE menu.

Press **OK** to accept.

Press **Up** or **Down** to increment the value.

Press **OK** to accept the value and go to next field.

Press **Menu** one of more times to go back to the home screen after all battery parameters have been configured.

Type

The Hybrid Power System has default charging parameters for the following types of batteries:

- Wet Cell
- Gel
- AGM

CAUTION *Mismatching TYPE with the installed coach batteries can lead to short battery life, resulting in loss of Hybrid Power System performance and availability.*

Capacity

Note: The BATTERY screen pops up with “0” in the Capacity field on startup if a value for Capacity has not been selected.

First determine the rated capacity of the installed coach batteries using the “20 Hour Battery Rating.” See *Appendix B. Battery Connections* on how to connect batteries to obtain the required Coach Battery Capacity (AHRS).

Pressing the Up button causes the values to increment from 0 to 380 and then up in increments of 20. Pressing the Down button causes the values to increment from 0 to 2000 and then down in increments of 20. The Hybrid Power System computes time remaining, time to charge and other battery parameters based on this value.

See *Section D. Specifications* for minimum battery capacity.

CAUTION *Unless CAPACITY matches capacity of installed coach batteries, battery charging will be unpredictable, resulting in loss of Hybrid Power System performance and availability.*

Low Warning

This is percentage of useable battery charge left when the the Low Battery warning light comes on.

Charger

Leave Charger ON. Turn OFF for service only.

The Charger field also indicates the current mode of charging: Blk – Bulk; Abs – Absorption; Flt – Float; or Eq1 – Equalize.

CAUTION *Leaving Charger OFF can disable the Hybrid Power System due to discharged batteries.*

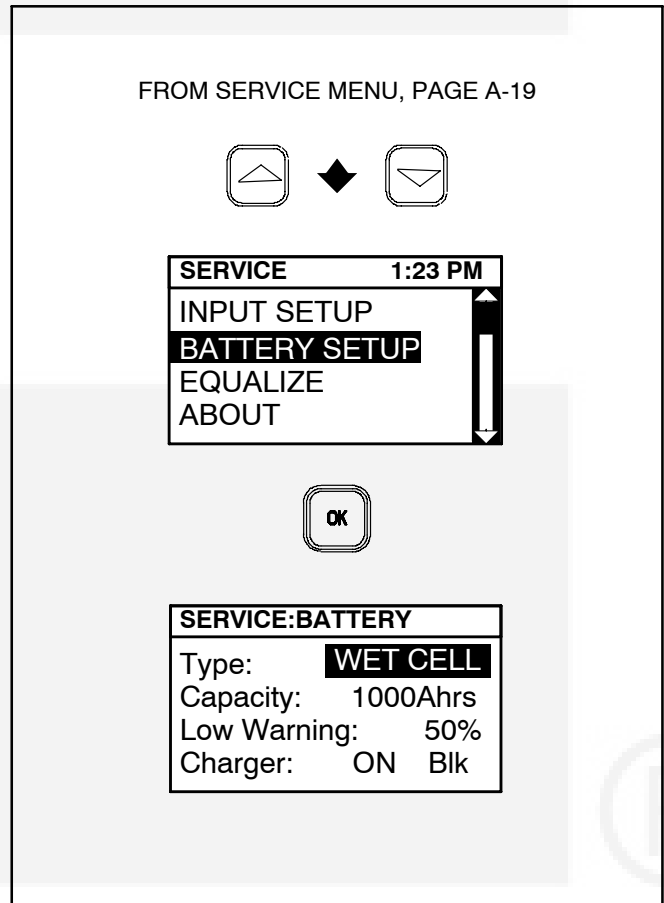

FIGURE A-20. BATTERY SETUP SCREEN

EQUALIZE

Safety Precautions

⚠ WARNING *Lead-Acid Batteries produce explosive hydrogen gas that can lead to severe personal injury. Do not smoke near batteries. Wear safety glasses. Keep sparks and other sources of ignition away.*

⚠ CAUTION *Turn the Coach DC Disconnect Switch to its Disconnect position to prevent damage from high equalizing voltage. Liability for damage to appliances left connected is the sole responsibility of the person performing equalizing.*

1. Turn the Coach DC Disconnect Switch to its Disconnect position before equalizing to prevent damage to appliances from the high equalizing voltage.
2. Equalizing causes water to evaporate from the battery cells. Add just enough distilled water before and after equalizing to cover the tops of the battery plates.
3. Open up the battery compartment as much as possible for better cooling and ventilation.
4. Batteries must be attended while equalizing. Be prepared to stop charging if a battery cell overflows, splits or cracks.
5. *It can take up to 6 hours to equalize the batteries.* Batteries must be attended while equalizing. Someone who has read and understood these instructions must be present to press STOP EQUALIZE if a battery overheats or a cell overflows, splits or cracks.

Start Equalize

Equalizing is enabled only when the Hybrid Power System is configured for Wet Cell batteries. EQUALIZE will not otherwise appear on the Service Menu.

Note: Shore power must be connected, the batteries must be fully charged and AUTO must be disabled. If the batteries are not fully charged the EQUALIZE screen will notify you that they must be full charged (Figure A-23).

Press **Up** or **Down** to select EQUALIZE on the SERVICE menu.

Press **OK** to Start EQUALIZE only after you have read these instructions, have determined that it is safe to equalize and are prepared to press STOP EQUALIZE if necessary.

Charging current will ramp up to 5 percent of coach battery capacity. (For example, the charging current for a 400 AHR battery bank would ramp up to 20 amps DC.) Once equalize voltage is reached (15.5 V), it is held for 30 minutes and the time remaining is recalculated. The total charging time, including up to 30 minutes for cooling, will not exceed 6 hours.

Note: START changes to STOP on this screen when Equalize starts.

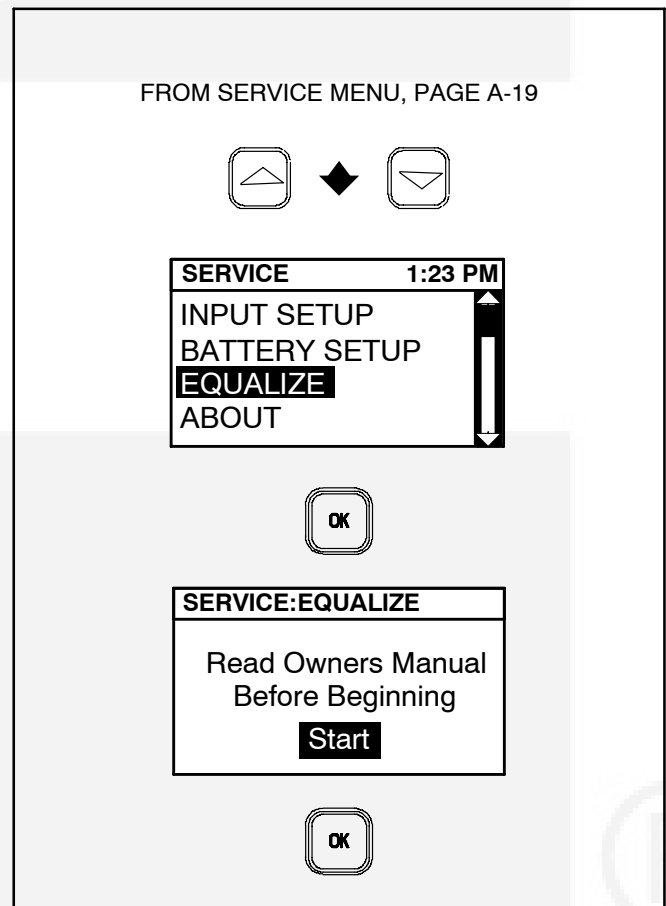

FIGURE A-21. START EQUALIZE SCREEN

STOP Equalize

Press **OK** to Stop EQUALIZE at any time. Batteries must be attended while equalizing. Be prepared to stop charging if a battery cell overflows, splits or cracks.

Normally, let equalize continue until it times out. A Time Remaining of 6 hours will be posted when EQUALIZE begins.

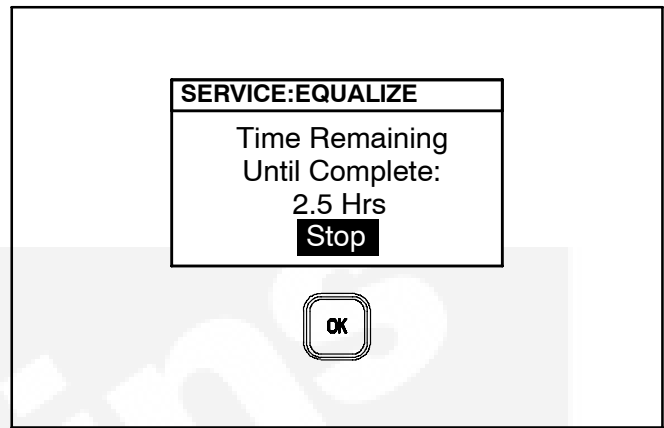

FIGURE A-22. STOP EQUALIZE SCREEN

If Batteries Are Not Fully Charged

If the batteries are not fully charged the EQUALIZE screen will notify you that they must be fully charged before equalizing. Press **OK** to disable Equalize Charging and connect shore power or start Generator Mode to fully charge the batteries.

Note: Equalize charging, once the batteries are fully charged, can take place only when shore power is connected.

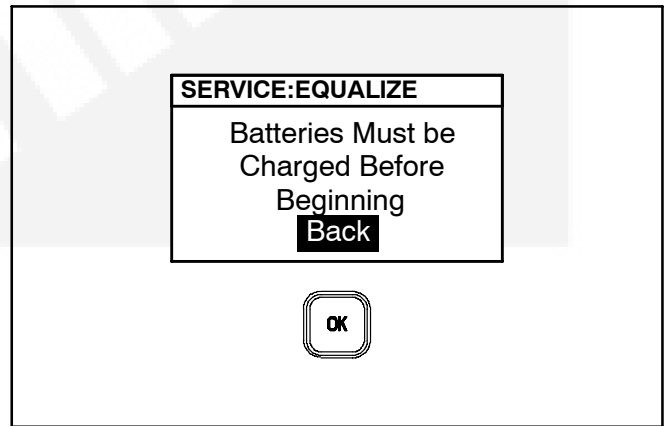

FIGURE A-23. NOT FULLY CHARGED SCREEN

ABOUT

Use these screens to find out the software part and version numbers of the components of the Hybrid Power System. You may be asked to provide these numbers when you call for service.

Press **Up** or **Down** to select ABOUT on the SERVICE menu.

Press **OK** to accept the selection.

Press **Up** or **Down** to select the component for which you need the software numbers.

Press **Menu** one or more times to go back to the home screen.

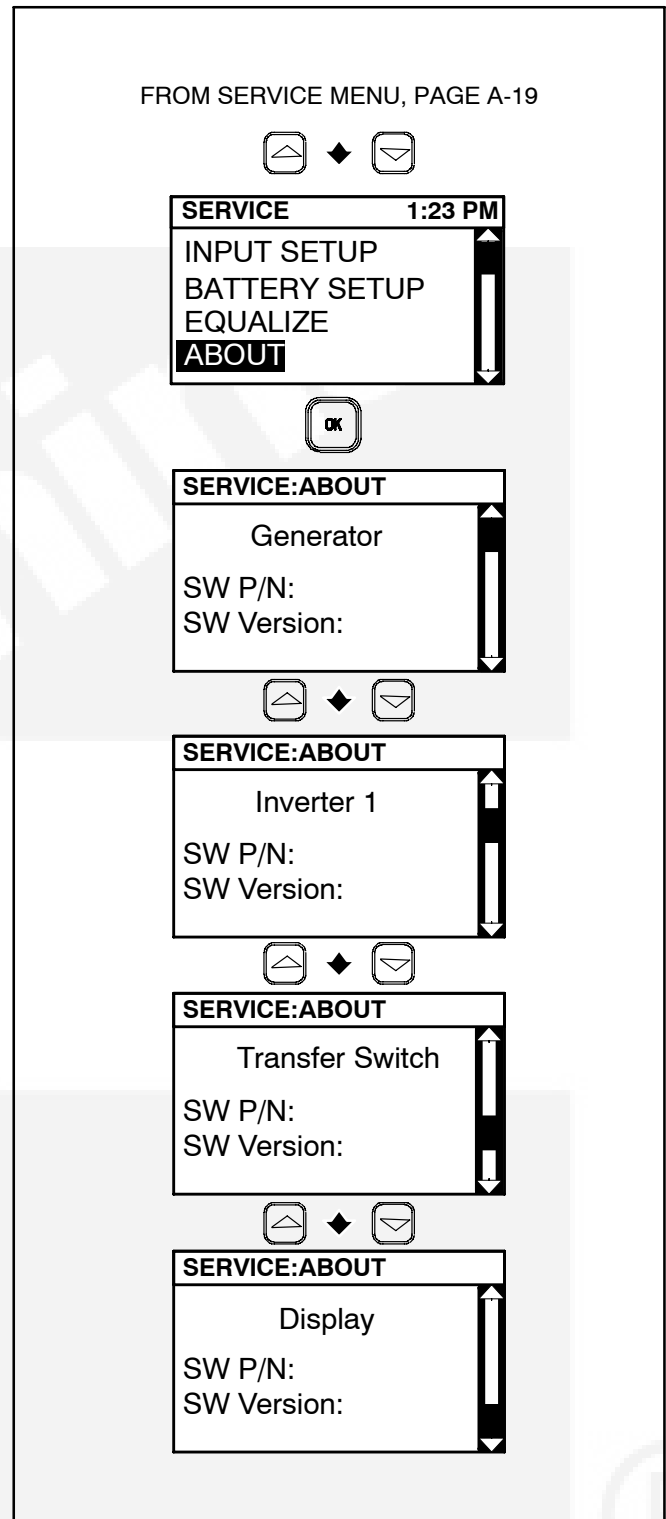

FIGURE A-24. ABOUT SCREEN

WARNING AND PROMPT SCREENS

Various warning and prompt screens may appear on the Operator Panel when the Hybrid Power System is operating.

Shore Power Detected

The SHORE POWER DETECTED prompt appears to confirm connection to shore power and prompt you to reset Breaker Size, if necessary (Figure A-25). The prompt times out in 10 minutes.

Press **Up** or **Down** to increment the breaker size. Choices are 10A, 15A, 20A, 30A and 50A.

Press **OK** to accept.

See SHORE BREAKER (p. A-17) for reasons for resetting Breaker Size.

Shore Quality Warning

If there is a loss or degradation of shore power, the SHORE QUALITY WARNING (Figure A-26) appears indicating the time of the disturbance and one of the following disturbances:

- Overfrequency
- Underfrequency
- Reverse Polarity
- High Voltage
- Low Voltage
- Loss of Neutral
- Loss of L1
- Loss of L2

See *Appendix D. Specifications* regarding acceptable shore power.

Press **OK** to continue operation with shore power and clear the screen. See SHORE STATUS (p. A-13) if the screen was cleared and it is necessary to review shore status. Call the shore power supplier for service if shore quality warnings persist.

⚠WARNING *Faulty electrical repairs can lead to severe personal injury or death. Connections and repairs must be made by a trained and experienced electrician in accordance with applicable electrical codes.*

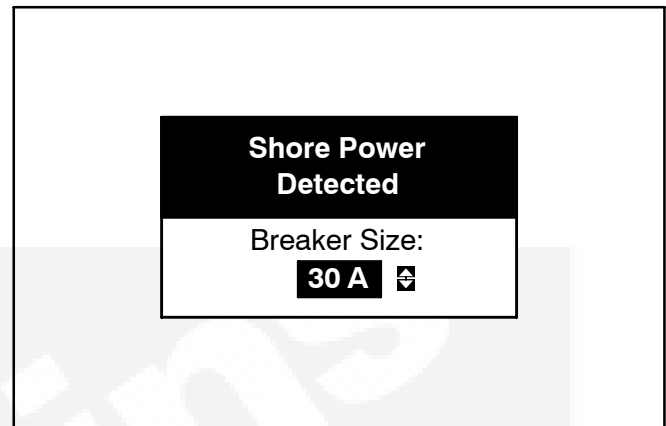

FIGURE A-25. SHORE POWER DETECTED

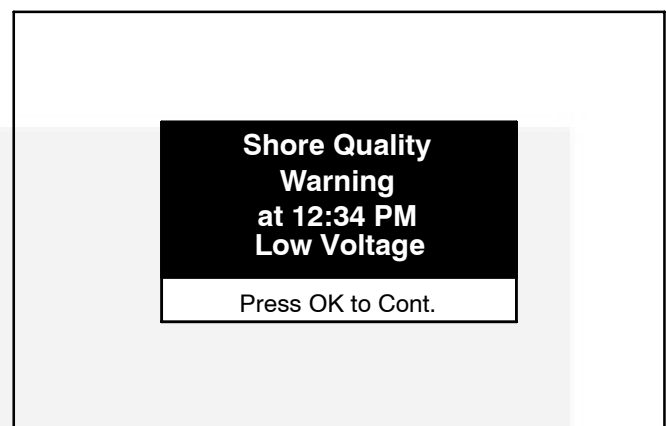

FIGURE A-26. SHORE QUALITY WARNING

Fault

If a warning or shutdown fault occurs in the Hybrid Power System, a FAULT warning appears (Figure A-27) with the following information:

- The three-digit Warning or Fault Code Number
- The time of occurrence of the warning or fault
- Brief description of the warning or fault

Press **OK** to continue and see *Troubleshooting Fault Codes* in the Service Manual.

The FAULT warning does not time out.

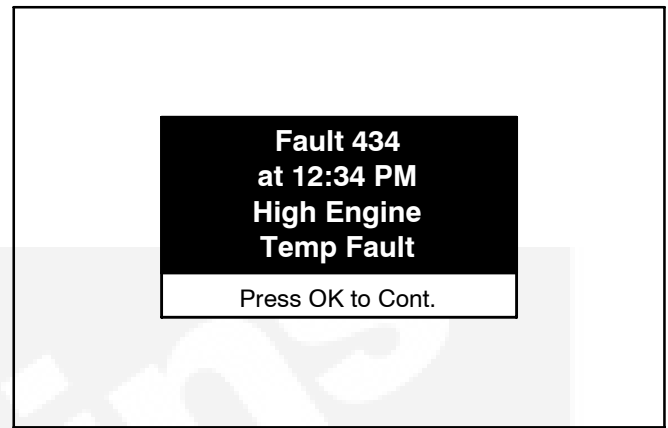

FIGURE A-27. FAULT WARNING

Auto Expiration

The AUTO safety input signal device must be cycled ON and OFF every 30 days to make sure it is still working. After 25 days a prompt appears that AUTO will expire in 5 days (Figure A-28). The countdown continues each subsequent day unless the safety input signal is cycled.

Press **OK** to move to the screen that identifies the safety input signal device your coach was set up to use. Cycle this signal device ON and OFF to reset AUTO for another 30 days. One of the following will be identified as the signal device set up for your coach:

- Brake Signal – With foot on the Brake, release and reset the Parking Brake to cycle the safety signal.
- Ignition Signal – Turn the Ignition Key to the accessory position and back to OFF to cycle the safety signal.
- Park Signal – With foot on the Brake, push the Transmission Shift Lever out of Park and back into Park to cycle the safety signal.

If the AUTO safety input signal has not been cycled ON and OFF for 30 days or more, the Safety Input Expired prompt appears indicating that the signal has expired (Figure A-29). Cycle the safety signal ON and OFF to restore the signal for another 30 days.

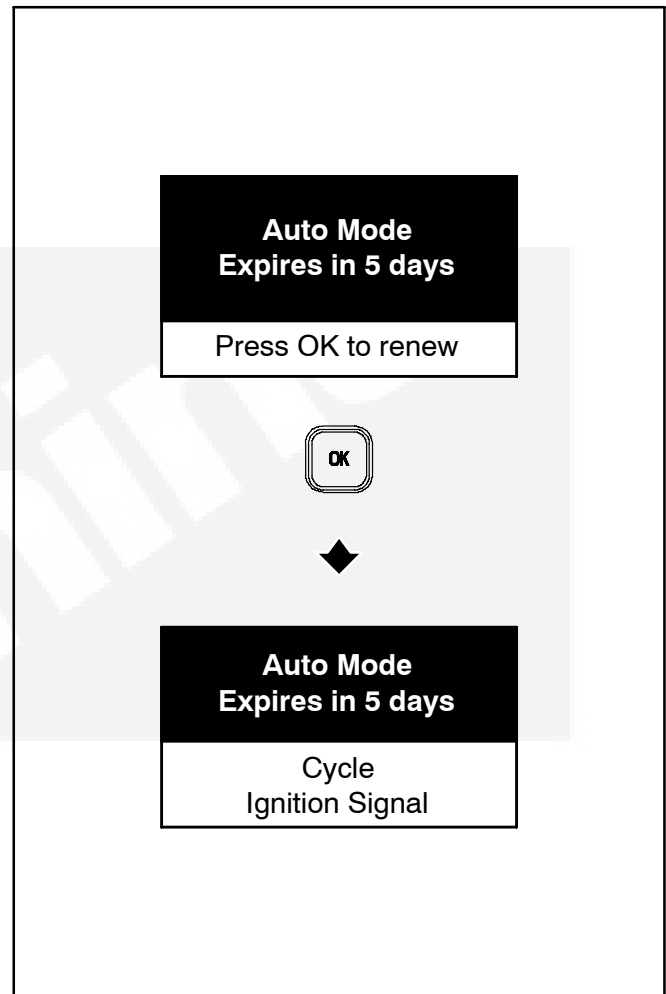

FIGURE A-28. AUTO TO EXPIRE

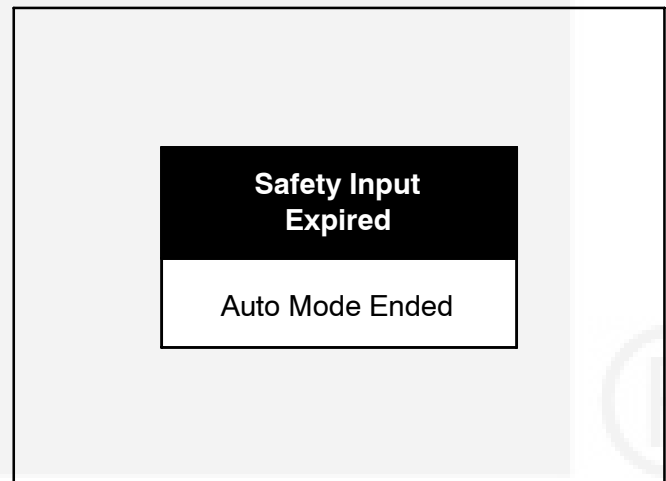

FIGURE A-29. AUTO EXPIRED

Cummins

This side is intended to be blank



Appendix B. Battery Interconnections

12 VOLT BATTERY INTERCONNECTIONS

Refer to Figure B-1 for 12 Volt Battery interconnections. Connect 12 Volt Batteries in Parallel: + to +, - to -. Battery Bank Voltage will be the same as individual battery voltage: 12 Volts. Battery Bank Capacity will be the sum of the individual battery capacities. If, for example, four 100 AHR batteries are connected in parallel, then:

$$\text{Battery Bank Capacity} = 100+100+100+100 = 400 \text{ AHRS}$$

6 VOLT BATTERY INTERCONNECTIONS

Refer to Figure B-1 for 6 Volt Battery interconnections. First, connect pairs of 6 Volt batteries in Series: + to -, + to -. Battery Bank Voltage will be the sum of the battery voltages: 12 Volts. (Series connections increase voltage, not AHRS.) Then, connect two or more pairs of batteries in Parallel. Battery Bank Capacity will be the sum of the battery-pair capacities. If, for example, two pairs of series-connected, 6 Volt, 200 AHR batteries are connected in parallel, then:

$$\text{Battery Bank Capacity} = 200+200 = 400 \text{ AHRS}$$

BATTERY BANK TERMINALS

Refer to Figure B-1 for Battery Bank Terminal connections. The Battery Bank Terminals must be the diagonally opposite + and - terminals of the Battery bank. When diagonally opposite terminals are used, the total current path for each battery will be the same, that is, have the same number of inter-battery cables and terminals (resistances) in its current path. This is necessary for maximum battery bank output and uniform battery charging.

BATTERY TEMPERATURE SENSOR

Bolt the battery temperature sensor (Figure B-1) to a centrally located positive (+) terminal for representative Battery Bank temperature sensing. The Battery Bank positive (+) terminal runs hottest because it has the highest current flow through it and is therefore not as representative of Battery Bank temperatures.

The battery temperature sensor lead connector plugs into the Inverter/Charger to provide feedback for temperature-compensated charging.

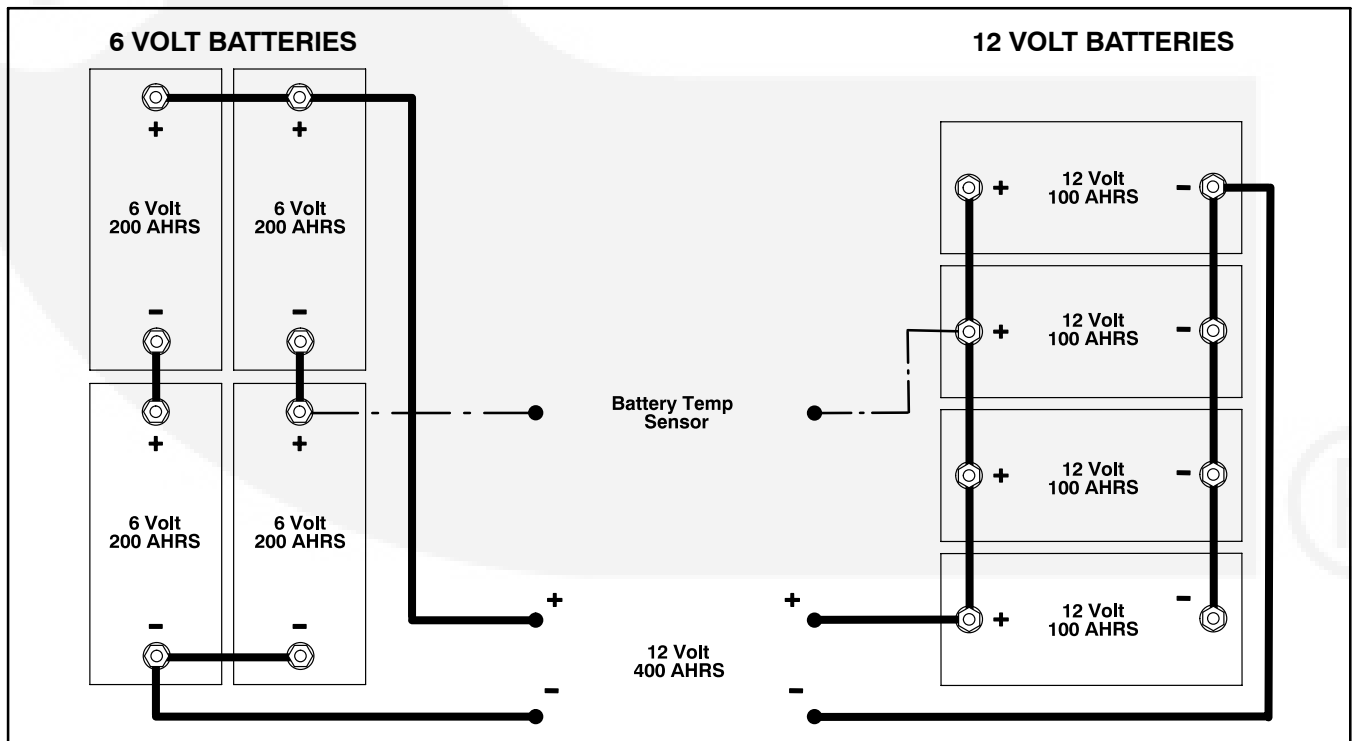

FIGURE B-1. BATTERY INTERCONNECTIONS FOR 12 VOLTS

Cummins

This side is intended to be blank



Appendix C. Hot Air Recirculation Test

⚠WARNING *EXHAUST GAS IS DEADLY! Do not operate the Hybrid Power System in Generator Mode when the coach is indoors unless there is ample fresh air ventilation.*

A representative installation of the Hybrid Power System must be tested to determine that neither Power Unit nor Inverter/Charger will overheat due to recirculation of hot air.

Test Method

1. Complete a representative installation.
2. Conduct the test in a well ventilated space in which carbon monoxide cannot accumulate, but that is protected from cross drafts that could affect temperature measurements.
3. Measure temperatures with shielded thermocouples not heavier than No. 24 AWG (0.25 mm²). A 2 inch diameter white PVC pipe 6 inches long is a good thermocouple shield. See Figure C-1.
4. Measure Power Unit inlet air temperature with a thermocouple secured about 1 inch below the air inlet.
5. Measure Inverter/Charger inlet air temperature with a thermocouple secured about 1 inch in front of the air inlet.
6. Measure outside ambient air temperature with a thermocouple within 4 feet (1.2 meters) of the Power Unit and at approximately the same

height. Make sure the thermocouple will not be affected by warm air discharged from the Power Unit or by sunlight.

7. If the Inverter/Charger is located inside the coach, measure coach inside ambient air temperature with a thermocouple located near the Inverter/Charger enclosure.
8. Close all Power Unit and Inverter/Charger enclosure doors, start the Hybrid Power System, connect 7.5 kW of constant load and run for at least 90 minutes. If air conditioners are used as loads, make sure they stay on and do not cycle during the test.
9. Record temperatures at 15 minute intervals. See Table C-1 for an example of how the data can be arranged for recording and analysis.

TABLE C-1. TEMPERATURE DATA

THERMOCOUPLE LOCATION	TEMPERATURE C° (F°)				
	Time Of Reading				
OUTSIDE AMBIENT AIR					
POWER UNIT AIR INLET					
INSIDE AMBIENT AIR					
INVERTER/CHARGER AIR INLET					

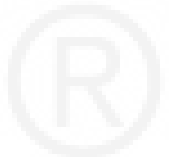

Test Requirement

Power Unit: Inlet air temperature must not exceed ambient air temperature by more than 15° F (8.3° C). A rise in inlet air temperature of more than this requires that steps be taken to reduce air recirculation.

Note: On very hot days Power Unit capacity could be noticeably affected if the air temperature rise in this

test is close to the maximum permitted rise. See Section D. Specifications for Power Unit rating at maximum operating temperature.

Inverter/Charger: Inlet air temperature must not exceed ambient air temperature by more than 27° F (15° C). A rise in inlet air temperature of more than this requires that steps be taken to relocate the Inverter/Charger or redesign the enclosure.

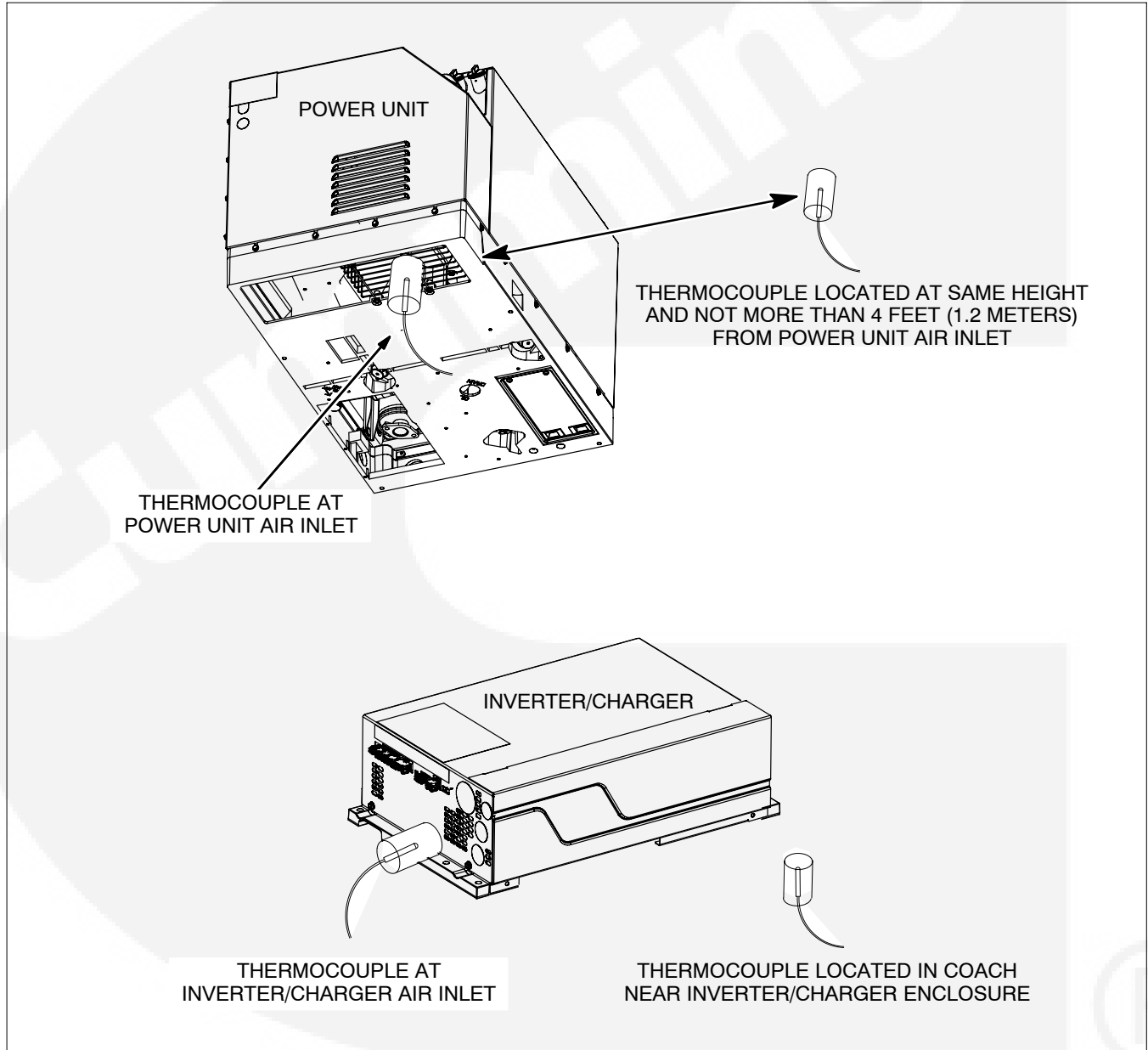

FIGURE C-1. THERMOCOUPLE LOCATIONS

Appendix D. Specifications

MODEL HQDSA HYBRID QUIET DIESEL POWER SYSTEM PERFORMANCE RATINGS	
System Operating Temperature Range	-22° F to 122° F (-30° C to 50° C)
Power Unit Sound: dB(A) at 10 ft (3 m) No-load Half-load (4000 W) Full-load	56 63 66
Generator Mode Output Voltage Maximum Continuous AC Output With Battery Boost—Peak Rating With Battery Boost—Surge Rating Air Conditioner Starting Capability	120 VAC 7500 Watts @ 104° F (40° C) 10,000 Watts 14,400 Watts Two 13,500 Btu Air Conditioners or Three 13,500 Btu High Efficiency Air Conditioners
Inverter Mode Maximum Continuous AC Output Surge Rating Air Conditioner Starting Capability	3000 Watts @ 104° F (40° C) 175% Single 13,500 Btu Air Conditioner
Shore Mode Maximum Continuous AC Output	30 A
MODEL HQDSA HYBRID QUIET DIESEL POWER CONTROL SYSTEM	
Integrated Microprocessors—Power Unit, Inverter/Charger, Transfer Switch, Operator Panel	
MODEL HQDPC POWER UNIT	
Maximum Continuous Power Output	8100 Watts @ 85° F (29° C) 6500 Watts @ 120° F (50° C)
Alternator Voltage Frequency Operating Speed Range	Three-Phase, Permanent Magnet Variable 150 to 240 Volts RMS L-L Variable 186 to 346 Hz 1400 to 2600 RPM
Engine Bore Stroke Displacement Compression Ratio Oil Capacity (with filter) Cooling System/Recovery Tank Capacity ¹ Intake and Exhaust Valve Lash (Cold) Fuel Nozzle Injection Pressure Cylinder Compression Test	3-Cylinder In-Line, Water-Cooled, Indirect-Injection, 4-Stroke Diesel 2.64 inch (67 mm) 2.68 inch (68 mm) 44 inch ³ (719 cc) 23 : 1 2.8 quart (2.6 l) 4 quart (3.2 l) 0.0065 inch (0.165 mm) 1991 psi (13.731 mPa) 370 psi (2.55 mPa) minimum
Engine Fuel Consumption No-load Half-load (4000 W) Full-load	0.11 gph (0.42 l/h) 0.48 gph (1.82 l/h) 0.76 gph (2.88 l/h)
Engine Cranking Current	200 amps

MODEL HQDTA AUTOMATIC TRANSFER SWITCH (ATS)	
Shore Power Service Power	120 VAC at 15 to 30 amps or 120/240 VAC up to 50 amps
HQD Input Power	120 VAC at up to 50 amps to L1-N and to L2-N
Shore Quality Monitoring	Connects when Conditions Met, Disconnects when Not Met
Voltage Range	95 to 132 L-N
Frequency Range	54 to 70 Hz
Under Voltage Disconnect Time	8 seconds
High Voltage (132 Vrms) Disconnect Time	1 second
Over Voltage (140 Vrms) Disconnect Time	0.1 seconds
Over/Under Frequency Disconnect Time	30 seconds
Loss or Ground Disconnect Time	0.5 seconds
Loss or Neutral Disconnect Time	0.5 seconds
Reverse Connection Disconnect Time	0.5 seconds
Shore Connection Time	3 seconds
Contactors Voltage Rating	120 VAC
Drop Out Voltage	70 VAC
Surge Suppression	1050 Joules
Shore Fuse Type	60A RK1 or K5
Shore to HQD Transition Time	30 seconds
MODEL HQDVA INVERTER/CHARGER	
Output Voltage (60 Hz, Sine)	120 VAC +/- 3%
Recommended Class T DC Fuse Rating (Amps)	400
Maximum Cable Length	10 ft
Minimum Cable Size	4/O
Voltage Band Width	+/- 0.5%
Output Frequency	60 Hz +/- 0.5%
Output Frequency Variation	+/- 0.1%
Output Waveform	Sine < 5% THD
Full Load Efficiency @ 77° F (25° C), 12 VDC	82%
Battery Types Supported	Wet Cell, Gel, AGM
Maximum Charging Current @ 14 VDC	140
Shore Power Power Factor when Charging	> 0.98
Shunt	High Side 50 mv, 500 amps
COACH BATTERY BANK REQUIREMENTS	
Nominal Voltage	12 VDC
Minimum Coach Battery Bank Capacity	390 Amp Hours
WEIGHTS AND DIMENSIONS	
Power Unit	
Weight (wet)	391 lbs (177 kg)
Length x Width x Height	36.3 x 23.6 x 22.3 inch (922 x 599 x 566 mm)
Inverter/Charger	
Weight	55 lbs (25 kg)
Length x Width x Height	21.1 x 13.39 x 6.4 inch (536 x 340 x 63 mm)
Transfer Switch	
Weight	17 lbs (8 kg)
Length x Width x Height	11.97 x 10.94 x 4.33 inch (304 x 278 x 110 mm)
1. Does not include Inverter/Charger cooling circuit capacity.	

Appendix E. Outline and System Drawings

SYSTEM DIAGRAM (SHEET 1 OF 8)	E-2
POWER UNIT (SHEET 2 OF 8)	E-3
INVERTER/CHARGER (SHEET 3 OF 8)	E-4
TRANSFER SWITCH (SHEET 4 OF 8)	E-5
OPERATOR PANEL (SHEET 5 OF 8)	E-6
12 VOLT DC SYSTEM DIAGRAM (SHEET 6 OF 8)	E-7
AC SYSTEM DIAGRAM (SHEET 7 OF 8)	E-8
COMMUNICATION CABLE SYSTEM DIAGRAM (SHEET 8 OF 8)	E-9
DIAGRAM—TYPICAL HYBRID POWER SYSTEM INSTALLATION	E-10
COMMUNICATIONS CABLES	E-11



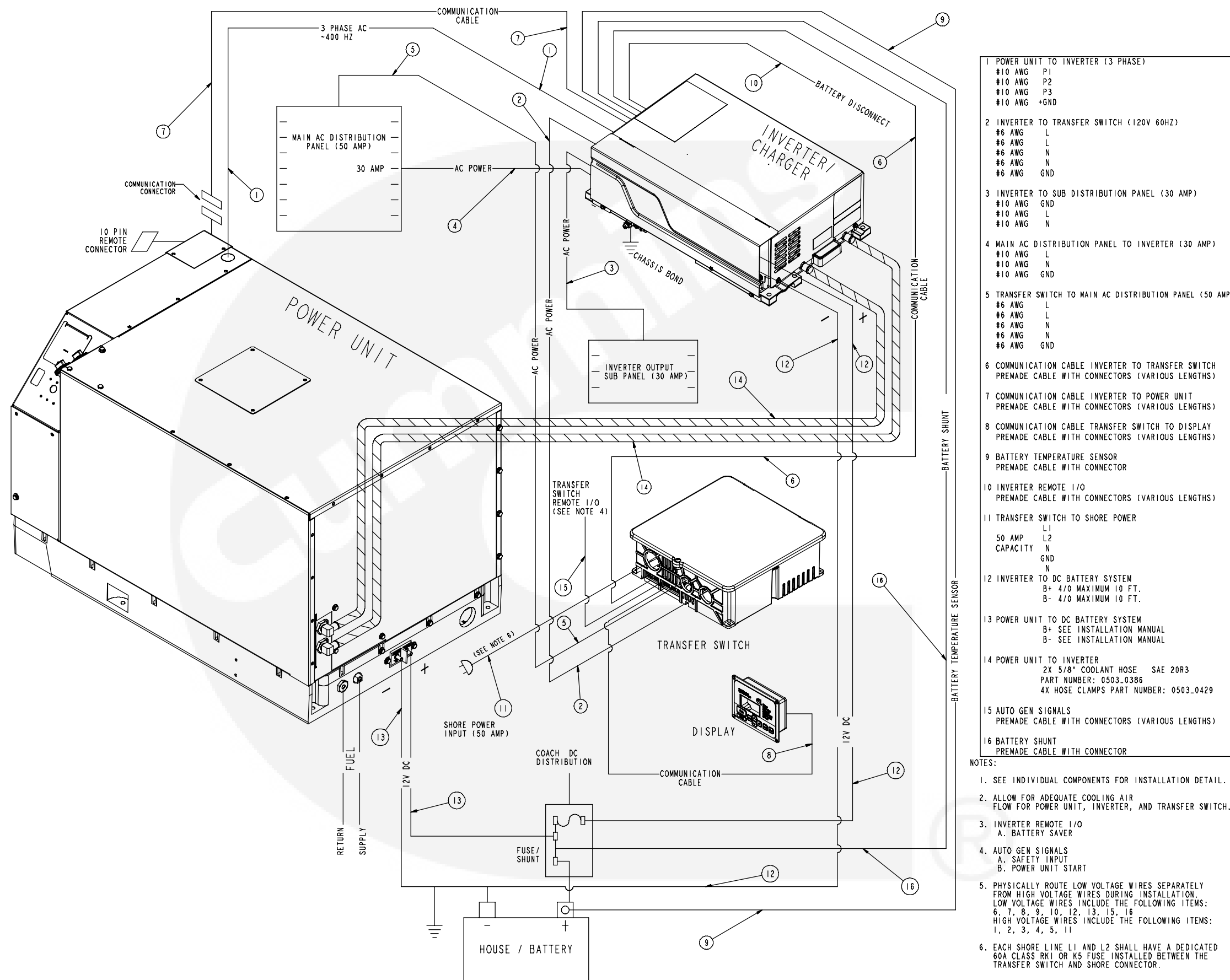

- 1 POWER UNIT TO INVERTER (3 PHASE)
#10 AWG P1
#10 AWG P2
#10 AWG P3
#10 AWG +GND
- 2 INVERTER TO TRANSFER SWITCH (120V 60HZ)
#6 AWG L
#6 AWG L
#6 AWG N
#6 AWG N
#6 AWG GND
- 3 INVERTER TO SUB DISTRIBUTION PANEL (30 AMP)
#10 AWG GND
#10 AWG L
#10 AWG N
- 4 MAIN AC DISTRIBUTION PANEL TO INVERTER (30 AMP)
#10 AWG L
#10 AWG N
#10 AWG GND
- 5 TRANSFER SWITCH TO MAIN AC DISTRIBUTION PANEL (50 AMP)
#6 AWG L
#6 AWG L
#6 AWG N
#6 AWG N
#6 AWG GND
- 6 COMMUNICATION CABLE INVERTER TO TRANSFER SWITCH
PREMADE CABLE WITH CONNECTORS (VARIOUS LENGTHS)
- 7 COMMUNICATION CABLE INVERTER TO POWER UNIT
PREMADE CABLE WITH CONNECTORS (VARIOUS LENGTHS)
- 8 COMMUNICATION CABLE TRANSFER SWITCH TO DISPLAY
PREMADE CABLE WITH CONNECTORS (VARIOUS LENGTHS)
- 9 BATTERY TEMPERATURE SENSOR
PREMADE CABLE WITH CONNECTOR
- 10 INVERTER REMOTE I/O
PREMADE CABLE WITH CONNECTORS (VARIOUS LENGTHS)
- 11 TRANSFER SWITCH TO SHORE POWER
L1
50 AMP L2
CAPACITY N
GND
N
- 12 INVERTER TO DC BATTERY SYSTEM
B+ 4/0 MAXIMUM 10 FT.
B- 4/0 MAXIMUM 10 FT.
- 13 POWER UNIT TO DC BATTERY SYSTEM
B+ SEE INSTALLATION MANUAL
B- SEE INSTALLATION MANUAL
- 14 POWER UNIT TO INVERTER
2X 5/8" COOLANT HOSE SAE 20R3
PART NUMBER: 0503_0386
4X HOSE CLAMPS PART NUMBER: 0503_0429
- 15 AUTO GEN SIGNALS
PREMADE CABLE WITH CONNECTORS (VARIOUS LENGTHS)
- 16 BATTERY SHUNT
PREMADE CABLE WITH CONNECTOR

- NOTES:
- 1. SEE INDIVIDUAL COMPONENTS FOR INSTALLATION DETAIL.
 - 2. ALLOW FOR ADEQUATE COOLING AIR FLOW FOR POWER UNIT, INVERTER, AND TRANSFER SWITCH.
 - 3. INVERTER REMOTE I/O
A. BATTERY SAVER
 - 4. AUTO GEN SIGNALS
A. SAFETY INPUT
B. POWER UNIT START
 - 5. PHYSICALLY ROUTE LOW VOLTAGE WIRES SEPARATELY FROM HIGH VOLTAGE WIRES DURING INSTALLATION. LOW VOLTAGE WIRES INCLUDE THE FOLLOWING ITEMS: 6, 7, 8, 9, 10, 12, 13, 15, 16
HIGH VOLTAGE WIRES INCLUDE THE FOLLOWING ITEMS: 1, 2, 3, 4, 5, 11
 - 6. EACH SHORE LINE L1 AND L2 SHALL HAVE A DEDICATED 60A CLASS RK1 OR K5 FUSE INSTALLED BETWEEN THE TRANSFER SWITCH AND SHORE CONNECTOR.

SYSTEM DIAGRAM (SHEET 1 OF 8)

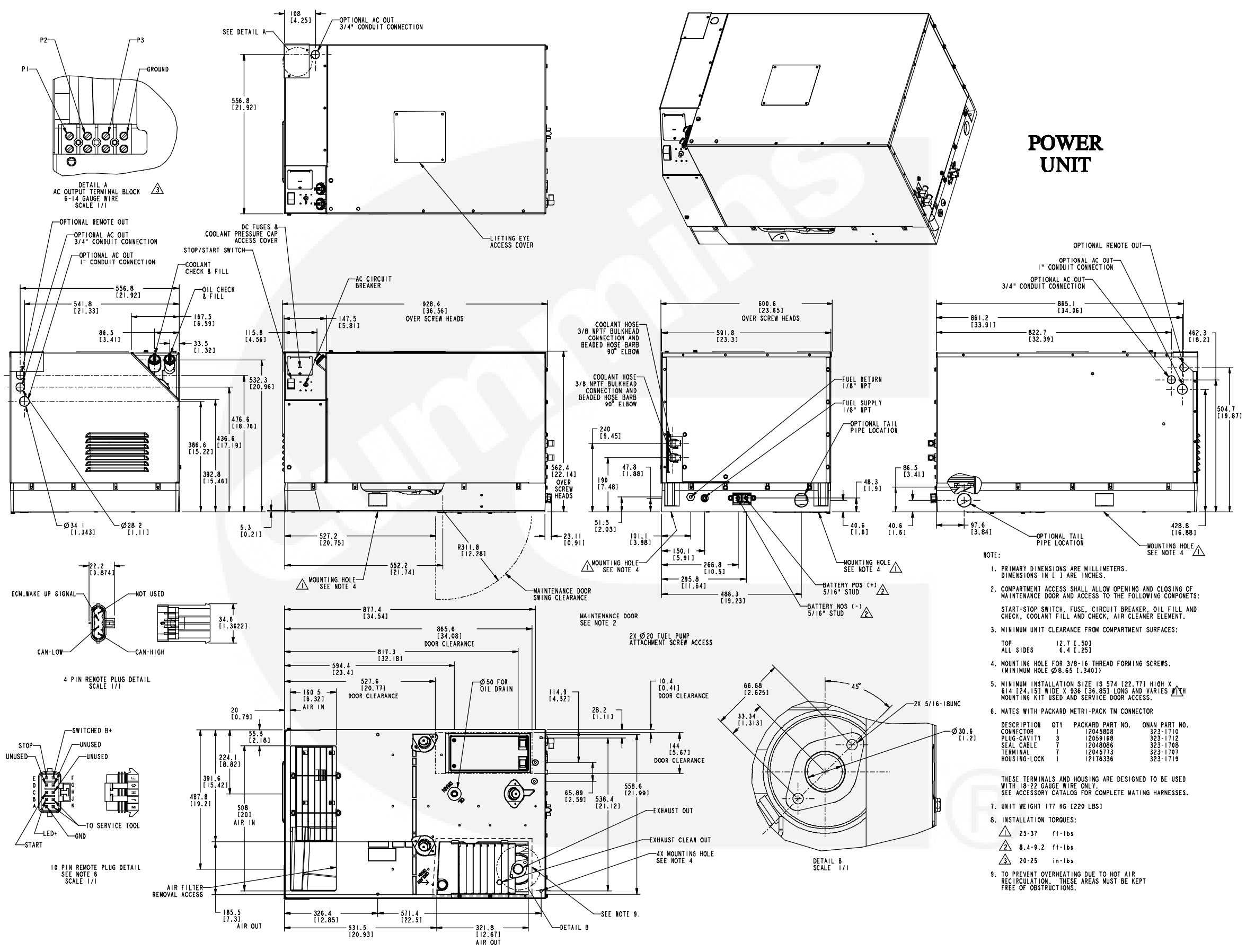

POWER UNIT

- NOTE:
- PRIMARY DIMENSIONS ARE MILLIMETERS. DIMENSIONS IN [] ARE INCHES.
 - COMPARTMENT ACCESS SHALL ALLOW OPENING AND CLOSING OF MAINTENANCE DOOR AND ACCESS TO THE FOLLOWING COMPONENTS:
START-STOP SWITCH, FUSE, CIRCUIT BREAKER, OIL FILL AND CHECK, COOLANT FILL AND CHECK, AIR CLEANER ELEMENT.
 - MINIMUM UNIT CLEARANCE FROM COMPARTMENT SURFACES:
TOP 12.7 [0.50]
ALL SIDES 6.4 [0.25]
 - MOUNTING HOLE FOR 3/8-16 THREAD FORMING SCREWS. (MINIMUM HOLE Ø8.65 [0.340])
 - MINIMUM INSTALLATION SIZE IS 574 [22.77] HIGH X 614 [24.15] WIDE X 936 [36.85] LONG AND VARIES WITH MOUNTING KIT USED AND SERVICE DOOR ACCESS.
 - MATES WITH PACKARD METRI-PACK™ CONNECTOR
- | DESCRIPTION | QTY | PACKARD PART NO. | ONAN PART NO. |
|--------------|-----|------------------|---------------|
| CONNECTOR | 1 | 12045008 | 323-1710 |
| PLUG-CAVITY | 3 | 12059168 | 323-1712 |
| SEAL CABLE | 7 | 12048086 | 323-1708 |
| TERMINAL | 7 | 12045713 | 323-1707 |
| HOUSING-LOCK | 1 | 12176336 | 323-1719 |
- THESE TERMINALS AND HOUSING ARE DESIGNED TO BE USED WITH 18-22 GAUGE WIRE ONLY. SEE ACCESSORY CATALOG FOR COMPLETE MATING HARNESSSES.
- UNIT WEIGHT 177 KG [220 LBS]
 - INSTALLATION TORQUES:
 - △ 25-37 ft-lbs
 - △ 8.4-9.2 ft-lbs
 - △ 20-25 in-lbs
 - TO PREVENT OVERHEATING DUE TO HOT AIR RECIRCULATION, THESE AREAS MUST BE KEPT FREE OF OBSTRUCTIONS.

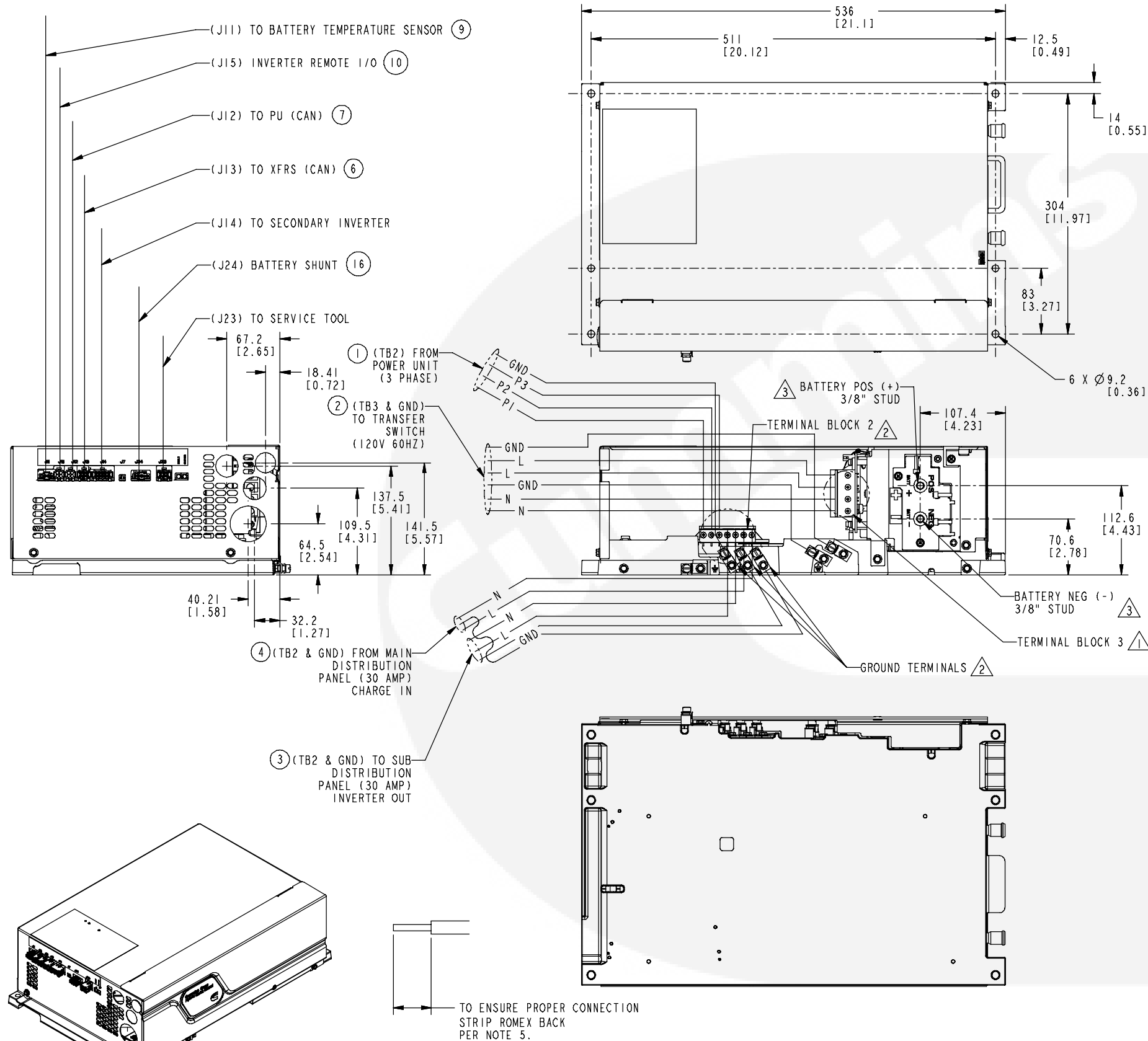

INVERTER/CHARGER

NOTE: ALL BALLOON ITEMS REFERENCE SHEET 1.

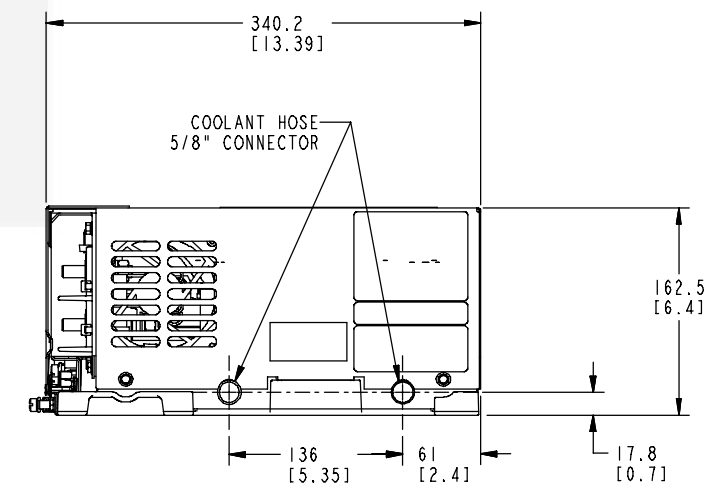

- NOTE:
1. PRIMARY DIMENSIONS ARE MILLIMETERS. DIMENSIONS IN [] ARE INCHES.
 2. MINIMUM UNIT CLEARANCE FROM COMPARTMENT SURFACES: BOTH ENDS 25.4 [1.0"]
 3. SHELF MOUNTED.
 4. WEIGHT: 25 kg [55 lbs]
 5. INSTALLATION TORQUES AND WIRE STRIP LENGTH

△1	25 in-lbs	STRIP WIRE BACK	.88 in
△2	20 in-lbs	STRIP WIRE BACK	.56 in
△3	11-15 ft-lbs		

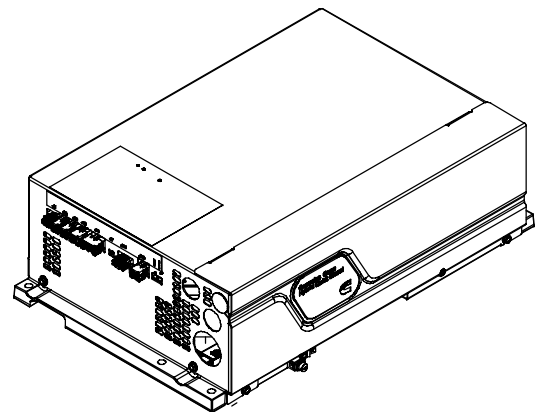

SCALE 1/4

NOTE: ALL BALLOON ITEMS REFERENCE SHEET 1.

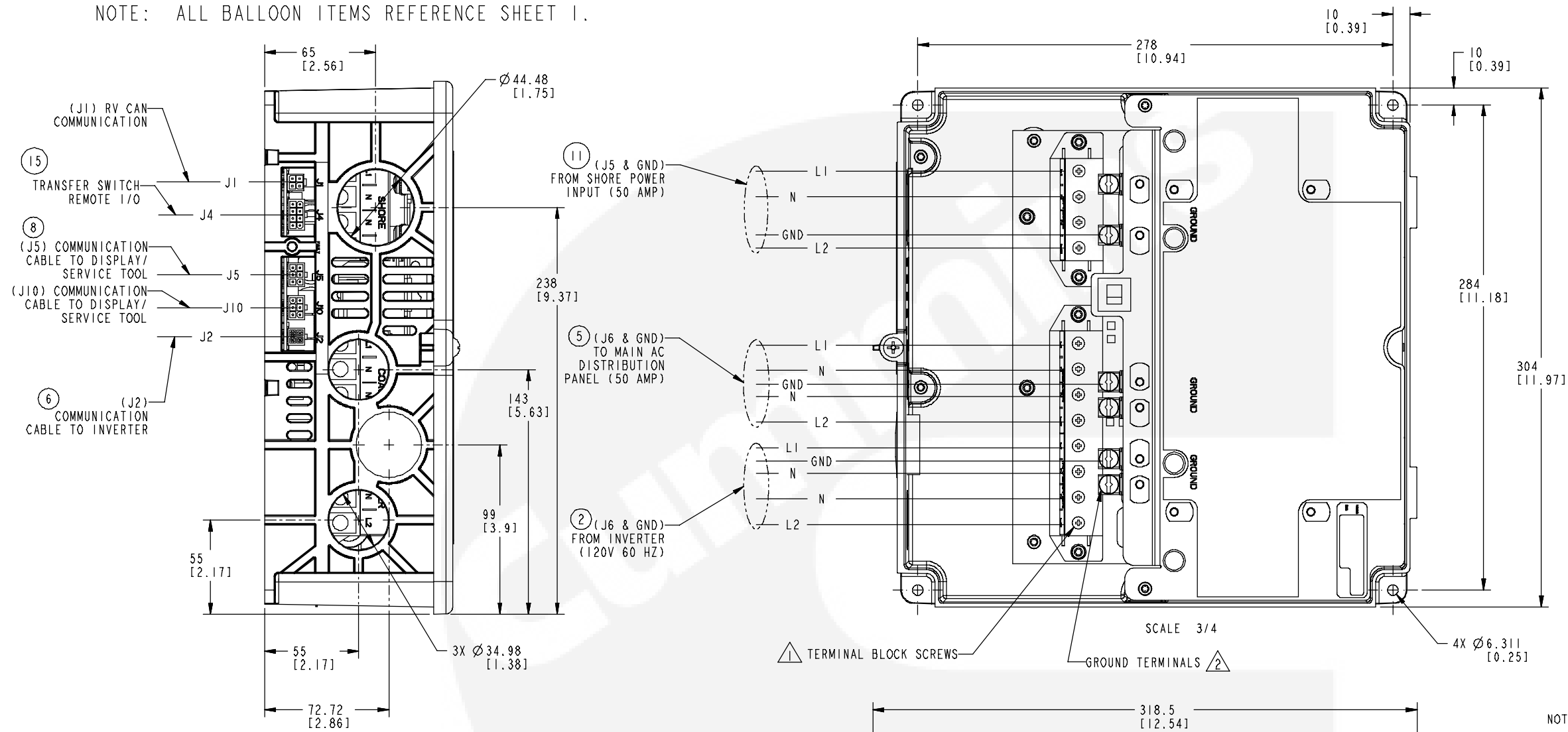

TRANSFER SWITCH

NOTE: UNIT MUST BE WALL MOUNTED. CEILING OR FLOOR MOUNTING MAY CAUSE SWITCH TO MALFUNCTION.

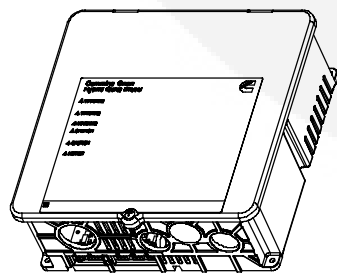

SCALE 1/4

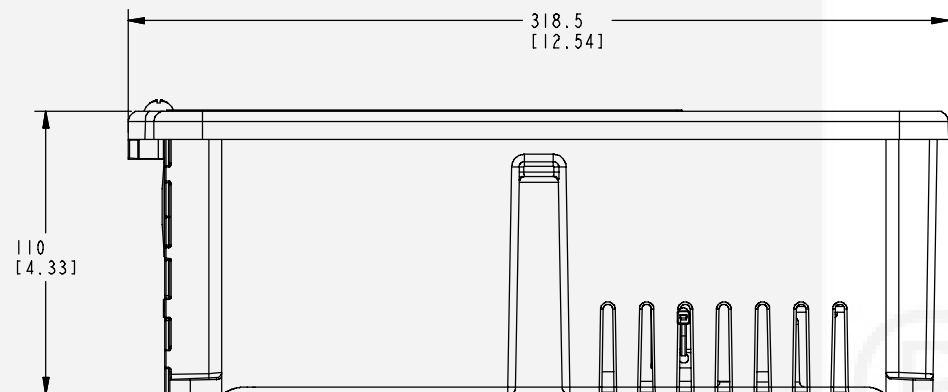

NOTE:

1. PRIMARY DIMENSIONS ARE MILLIMETERS. DIMENSIONS IN [] ARE INCHES.
 2. MINIMUM UNIT CLEARANCE FROM COMPARTMENT SURFACES ALL SIDES: 12.7 [0.5"]
 3. WEIGHT: 8 kg [17 lbs]
 4. REQUIRED WIRE STRIP LENGTH: .88 in
- ⚠ TORQUE TERMINALS TO 25 in-lbs
 ⚠ TORQUE TERMINALS TO 20 in-lbs

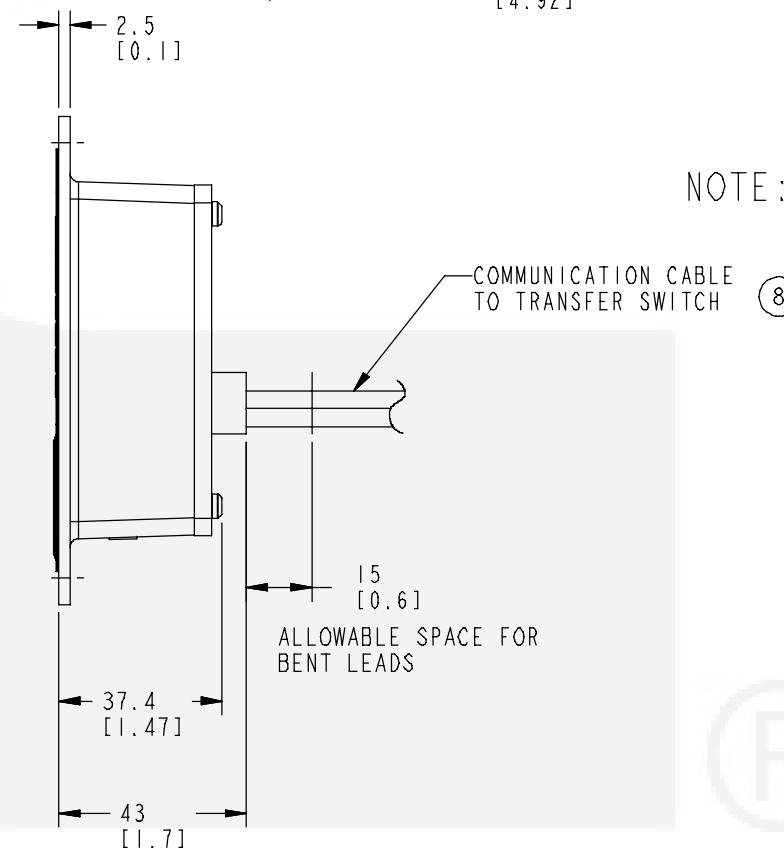
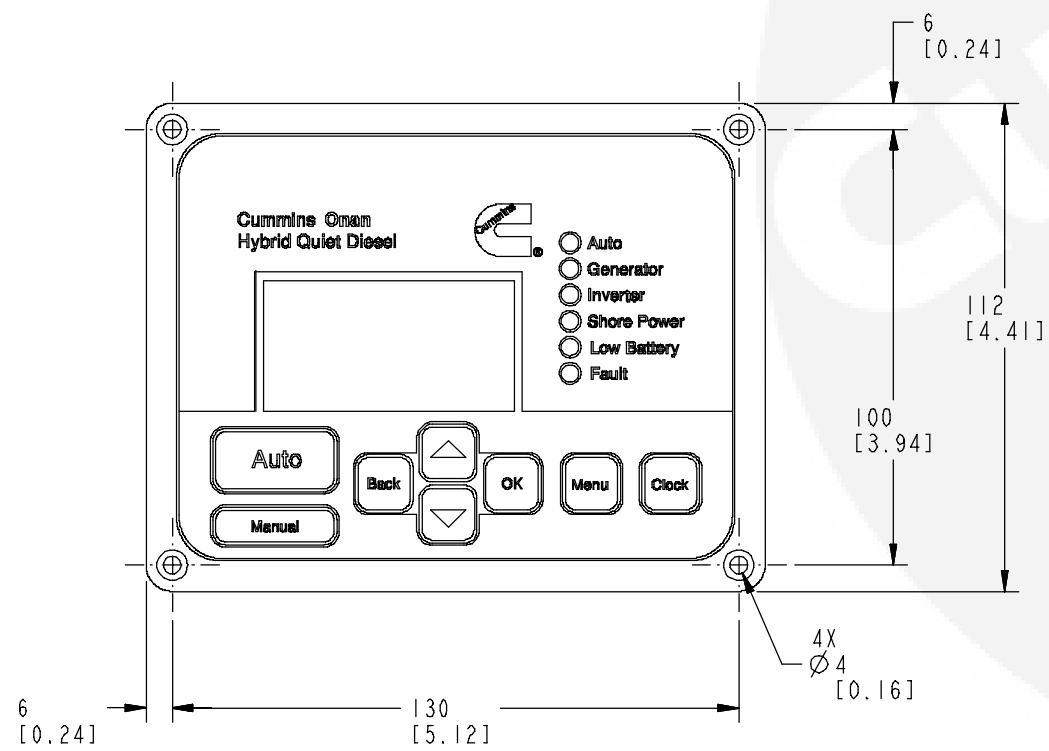
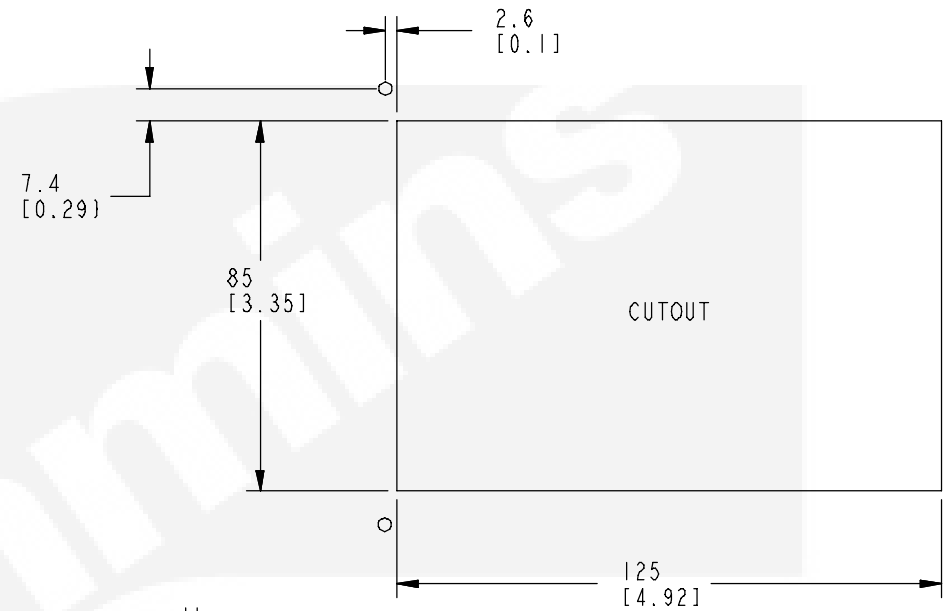
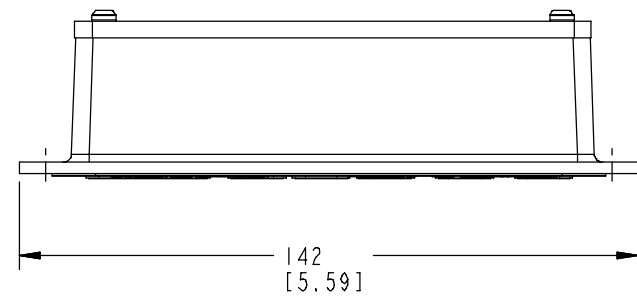

NOTE: ALL BALLOON ITEMS REFERENCE SHEET 1.

NOTE:
1. PRIMARY DIMENSIONS ARE MILLIMETERS.
DIMENSIONS IN [] ARE INCHES.

12 VOLT SYSTEM DIAGRAM

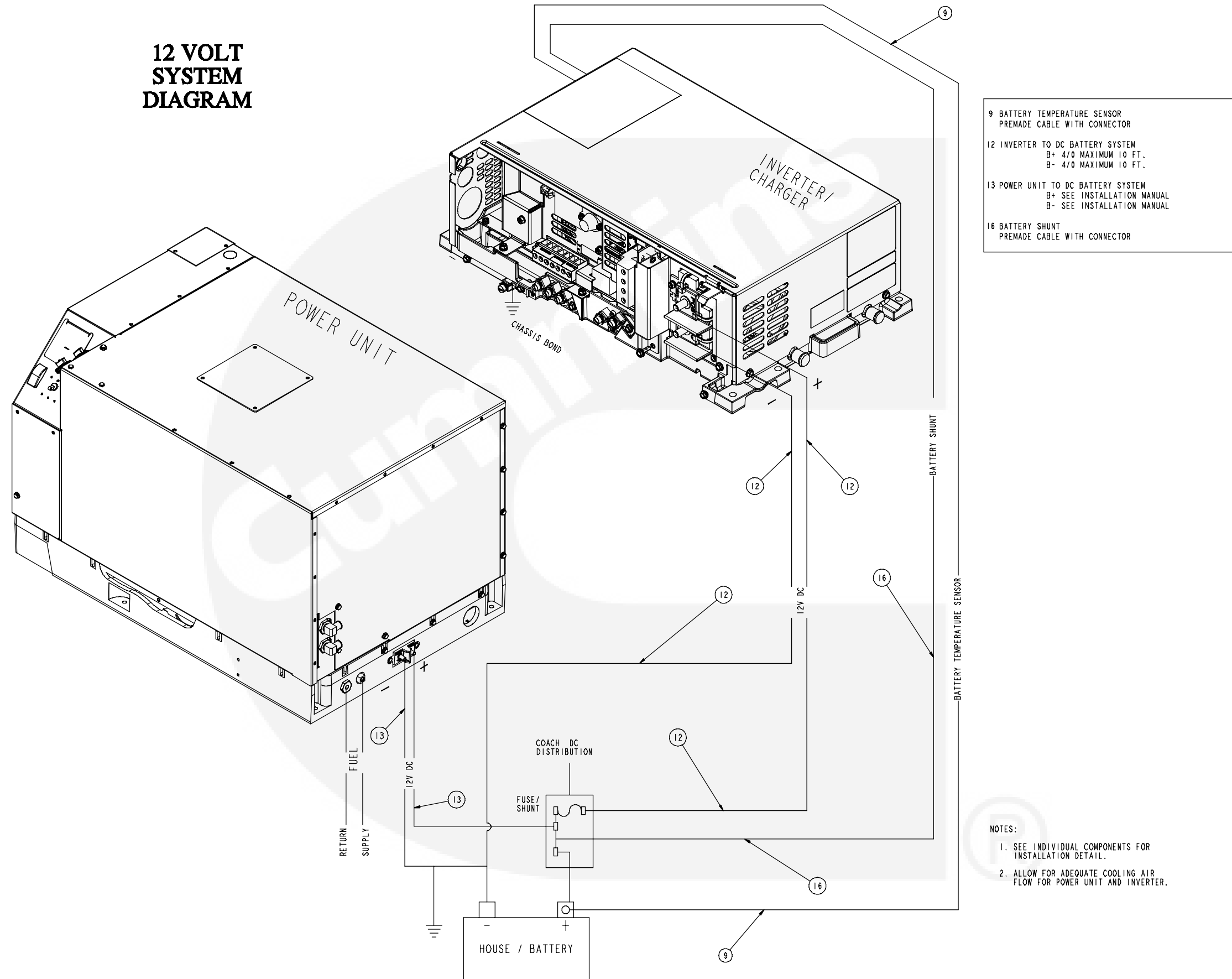

- 9 BATTERY TEMPERATURE SENSOR
PREMADE CABLE WITH CONNECTOR
- 12 INVERTER TO DC BATTERY SYSTEM
B+ 4/0 MAXIMUM 10 FT.
B- 4/0 MAXIMUM 10 FT.
- 13 POWER UNIT TO DC BATTERY SYSTEM
B+ SEE INSTALLATION MANUAL
B- SEE INSTALLATION MANUAL
- 16 BATTERY SHUNT
PREMADE CABLE WITH CONNECTOR

- NOTES:
1. SEE INDIVIDUAL COMPONENTS FOR INSTALLATION DETAIL.
 2. ALLOW FOR ADEQUATE COOLING AIR FLOW FOR POWER UNIT AND INVERTER.

POWER UNIT

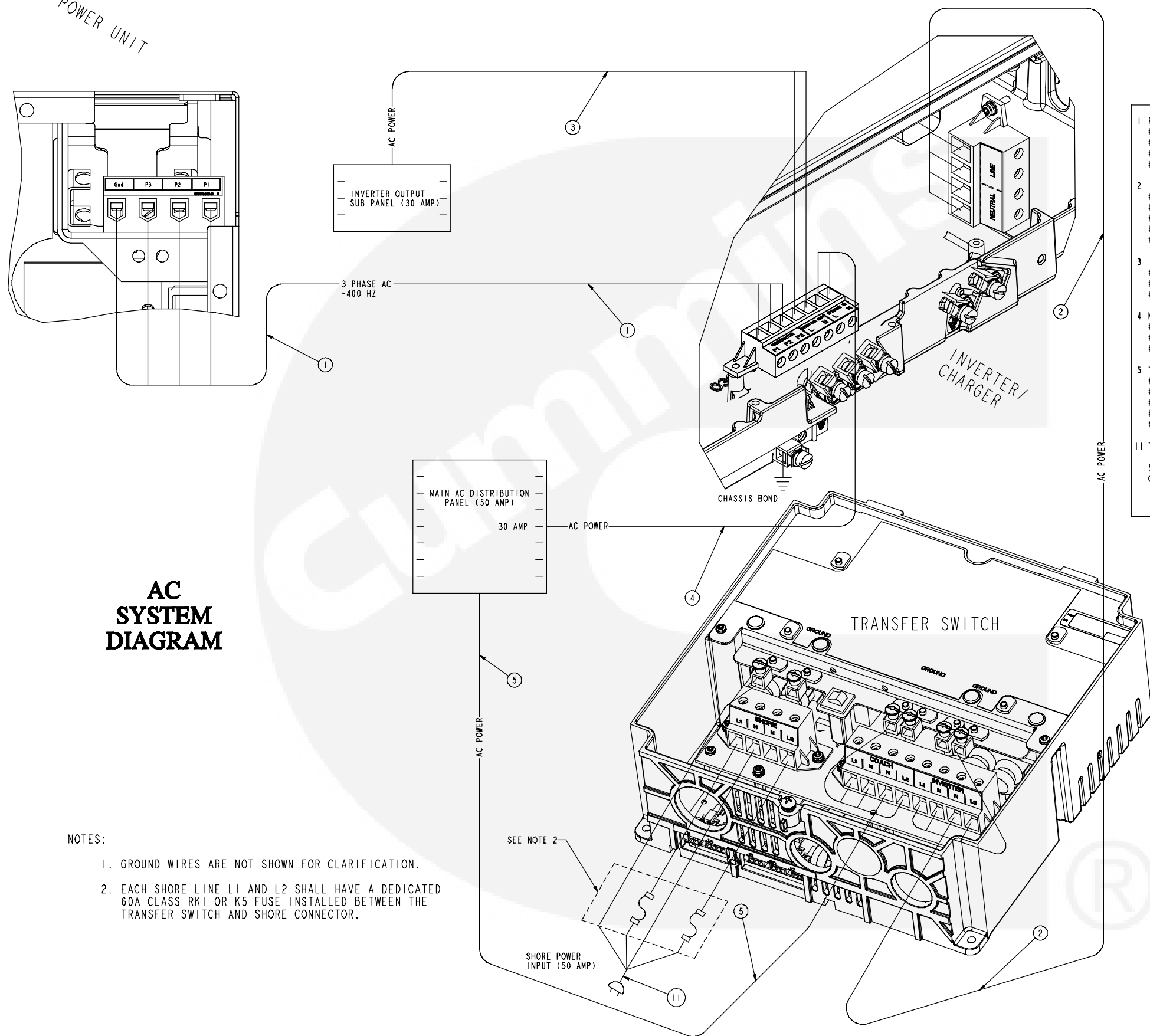

1	POWER UNIT TO INVERTER (3 PHASE)
	#10 AWG P1
	#10 AWG P2
	#10 AWG P3
	#10 AWG +GND
2	INVERTER TO TRANSFER SWITCH (120V 60HZ)
	#6 AWG L
	#6 AWG L
	#6 AWG N
	#6 AWG N
	#6 AWG GND
3	INVERTER TO SUB DISTRIBUTION PANEL (30 AMP)
	#10 AWG GND
	#10 AWG L
	#10 AWG N
4	MAIN AC DISTRIBUTION PANEL TO INVERTER (30 AMP)
	#10 AWG L
	#10 AWG N
	#10 AWG GND
5	TRANSFER SWITCH TO MAIN AC DISTRIBUTION PANEL (50 AMP)
	#6 AWG L
	#6 AWG L
	#6 AWG N
	#6 AWG N
	#6 AWG GND
11	TRANSFER SWITCH TO SHORE POWER
	L1
	50 AMP L2
	CAPACITY N
	GND N

AC SYSTEM DIAGRAM

- NOTES:
1. GROUND WIRES ARE NOT SHOWN FOR CLARIFICATION.
 2. EACH SHORE LINE L1 AND L2 SHALL HAVE A DEDICATED 60A CLASS RK1 OR K5 FUSE INSTALLED BETWEEN THE TRANSFER SWITCH AND SHORE CONNECTOR.

COMMUNICATION CABLE SYSTEM DIAGRAM

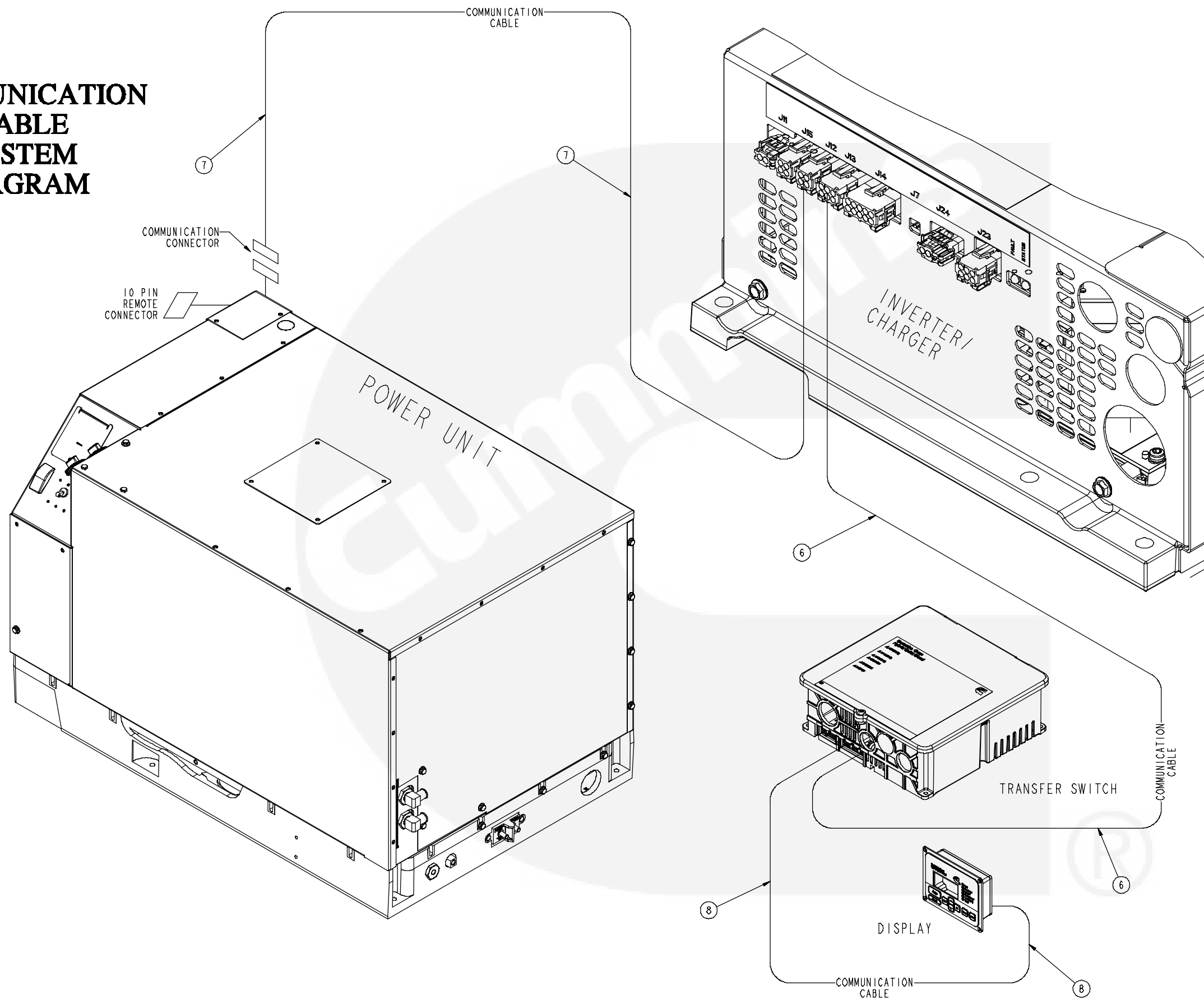

- 6 COMMUNICATION CABLE INVERTER TO TRANSFER SWITCH
PREMADE CABLE WITH CONNECTORS (VARIOUS LENGTHS)
- 7 COMMUNICATION CABLE INVERTER TO POWER UNIT
PREMADE CABLE WITH CONNECTORS (VARIOUS LENGTHS)
- 8 COMMUNICATION CABLE TRANSFER SWITCH TO DISPLAY
PREMADE CABLE WITH CONNECTORS (VARIOUS LENGTHS)

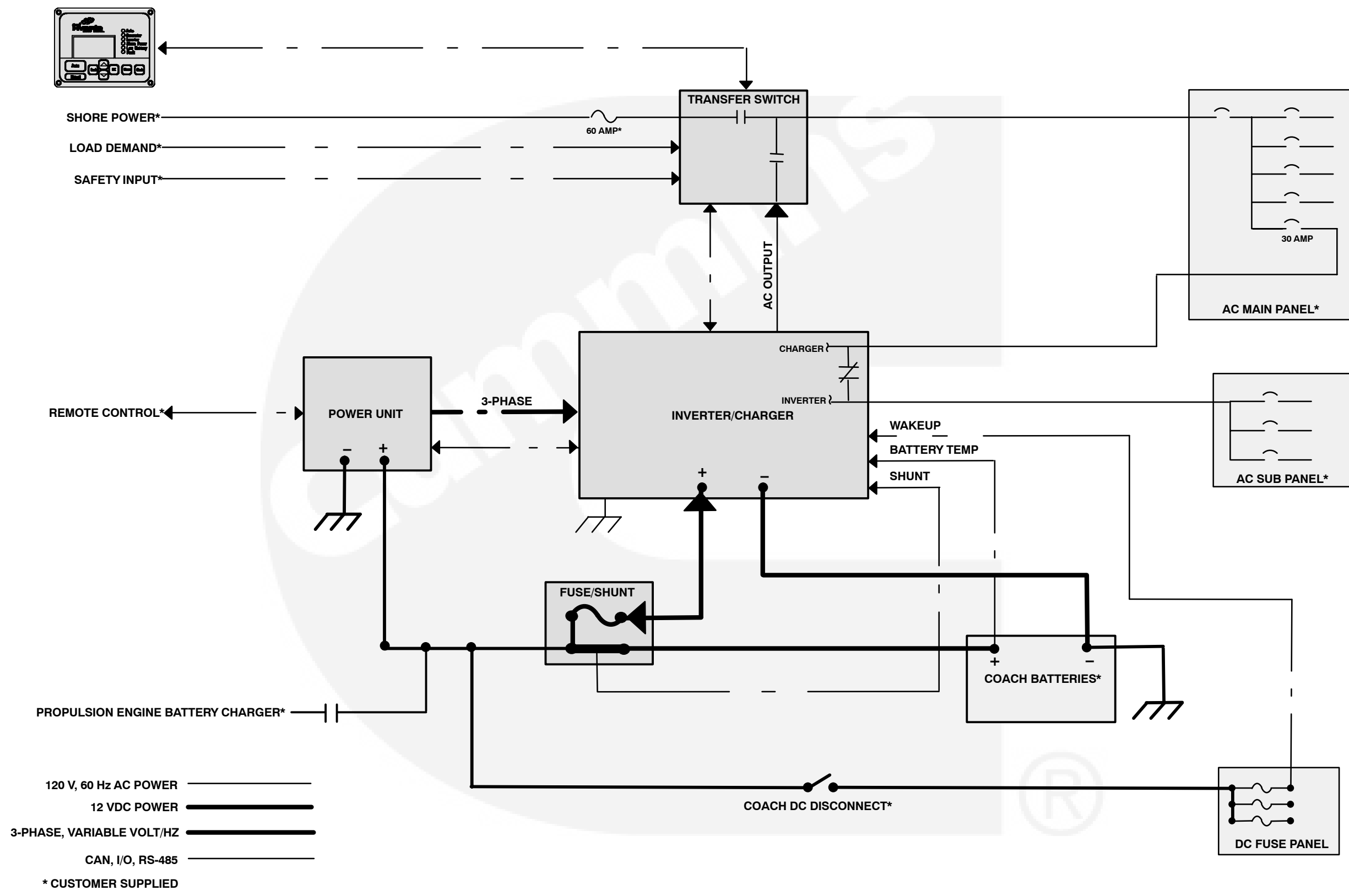

DIAGRAM—TYPICAL HYBRID POWER SYSTEM INSTALLATION

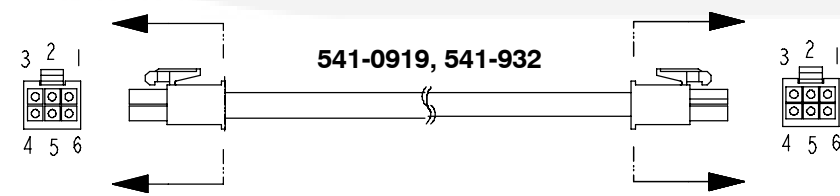
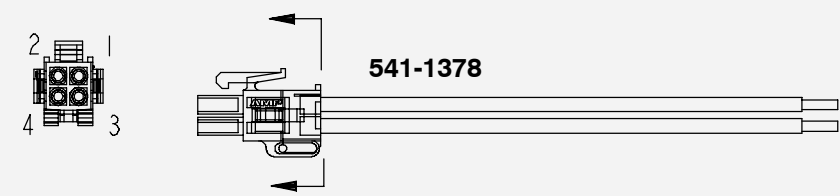
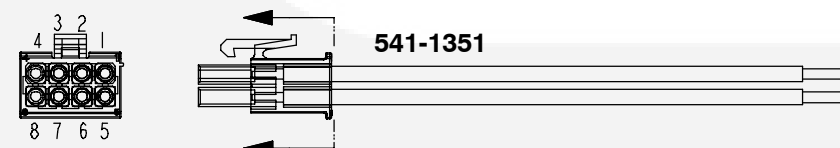
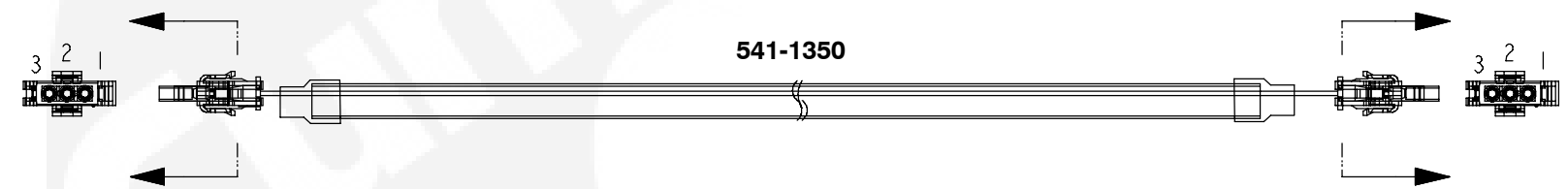
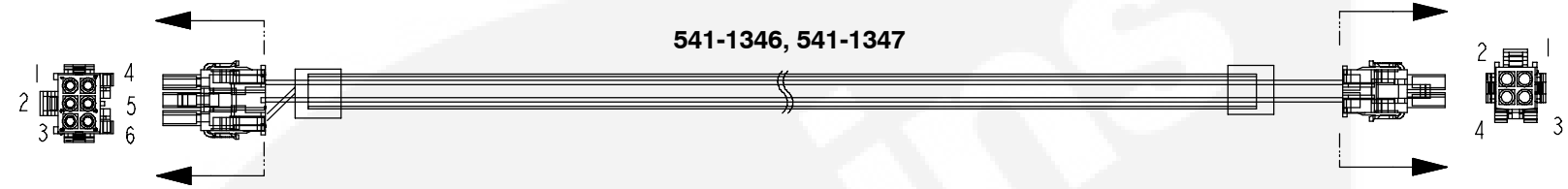
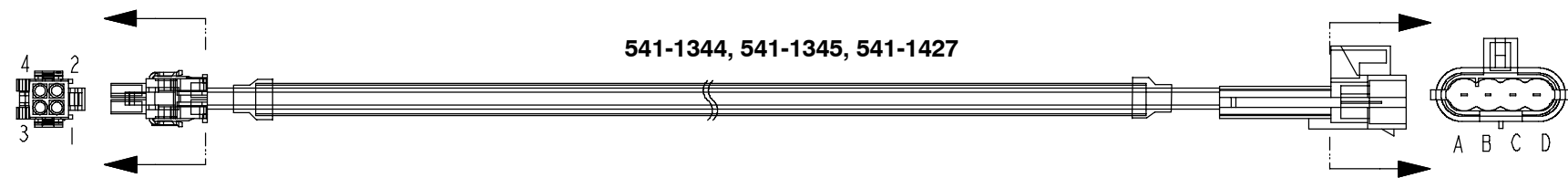

COMMUNICATIONS CABLES

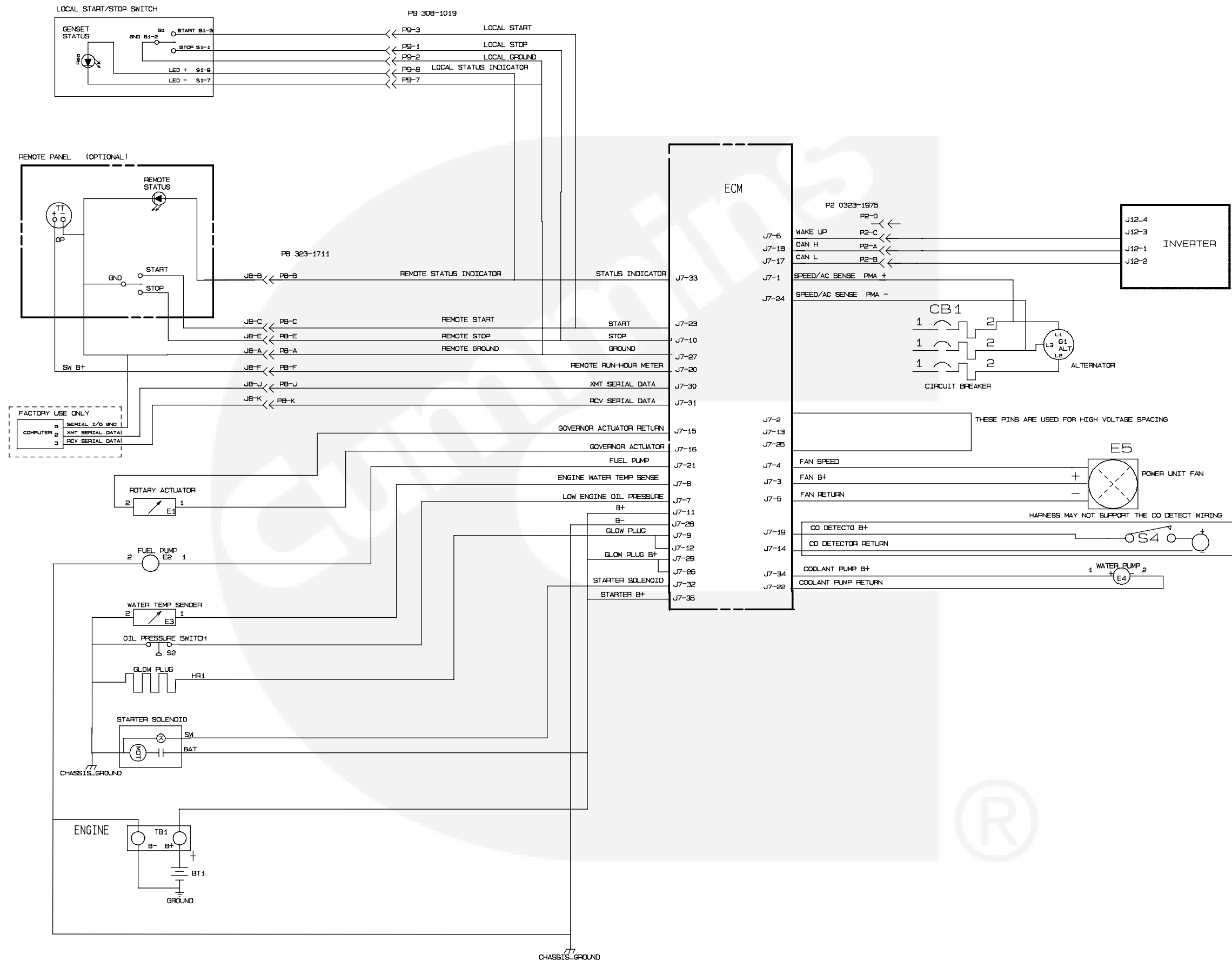

Cummins

Cummins **Onan**

Cummins Power Generation

1400 73rd Ave. NE
Minneapolis, MN 55432 USA

Phone 1 763 574 5000

Toll-free 1 800 888 6626

Fax 1 763 574 5298

Email www.cumminsonan.com/contact

www.cumminsonan.com

Cummins®, Onan®, the "C" logo, and "Performance you rely on." are trademarks of Cummins Inc.

©2007 Cummins Power Generation, Inc. All rights reserved.

