

Cummins *RV GenSet*

Operator's Manual

KY

MicroLite™ 4000 Series



Printed in U.S.A.

981-0139
9-94

Table of Contents

TITLE	PAGE
SAFETY PRECAUTIONS	ii, iii
INTRODUCTION	1
About This Manual	1
Model Identification	1
Component Locations	2
CONTROL PANEL	3
Standard Control Panel	3
Remote Control Panel (Optional)	4
PRE-START CHECKS	5
Engine Oil	5
Exhaust Check	6
Fuel Check	6
General Inspection	6
STARTING AND STOPPING	7
Starting Procedure	7
Stopping	8
WATTAGE REQUIREMENTS	9
AC Wattage Capacity	9
DC Power	10
OPERATING RECOMMENDATIONS	11
Break-In Procedure	11
Operating in Hot or Cold Weather	11
High Altitude	11
Operating in Dusty Conditions	12
Generator Set Exercise	12
MAINTENANCE SCHEDULE	13
MAINTENANCE PROCEDURES	14
General Inspection	14
Oil Change	15
Battery Care	17
Air Filter Replacement	18
Spark Plug	19
Spark Arrester Service	19
GENERATOR SET STORAGE	20
TROUBLESHOOTING	21
HOW TO OBTAIN SERVICE	22
SPECIFICATIONS	23
MAINTENANCE RECORD	25

Safety Precautions

Before operating the generator set, read the Operator's Manual and become familiar with it and the equipment. **Safe and efficient operation can be achieved only if the unit is properly operated and maintained.** Accidents are usually caused by failure to follow fundamental rules and precautions.

The following symbols, found throughout this manual, alert you to potentially dangerous conditions to the operator, service personnel, or the equipment.

⚠ DANGER *This symbol warns of immediate hazards which will result in severe personal injury or death.*

⚠ WARNING *This symbol refers to a hazard or unsafe practice which can result in severe personal injury or death.*

⚠ CAUTION *This symbol refers to a hazard or unsafe practice which can result in personal injury or product or property damage.*

Read and observe each of the following safety precautions.

FUEL AND FUMES ARE FLAMMABLE

Fire, explosion, and personal injury can result from improper practices.

- Do not smoke or allow an open flame or spark-producing equipment near the generator set or fuel tank.
- Inspect the fuel lines and connections daily for leaks per the maintenance schedule.

EXHAUST GASES ARE DEADLY

- Never sleep in the vehicle with the generator set running unless vehicle is equipped with an operating carbon monoxide detector.

- Inspect exhaust system daily for leaks per the maintenance schedule. Do not use engine cooling air to heat a compartment.
- Never operate the generator set inside a building or in an area where exhaust gases could accumulate, such as near a wall or snow bank, or in high grass. When parking, make sure the exhaust outlet is not obstructed. Make sure the generator set is well ventilated.

ELECTRICAL SHOCK CAN CAUSE SEVERE PERSONAL INJURY OR DEATH

- Disconnect the negative (–) cable at the starting battery before removing protective shields or touching electrical equipment. Use rubber insulative mats placed on dry wood platforms over the ground or over floors that are metal or concrete, when around electrical equipment. Do not wear damp clothing (particularly wet shoes) or allow skin surfaces to be damp when handling electrical equipment.
- Use extreme caution when working on electrical components. High voltages can cause injury or death.
- Tag remote or open switches to avoid accidental closure or starting.
- **DO NOT CONNECT GENERATOR SET DIRECTLY TO ANY BUILDING ELECTRICAL SYSTEM.** Hazardous voltages can flow from the generator set into the utility line. This creates a potential for electrocution or property damage. Connect only through an approved device and after building main switch is open. Consult an electrician in regard to emergency power use.

MOVING PARTS CAN CAUSE SEVERE PERSONAL INJURY OR DEATH

- Before starting work on the generator set, disconnect the negative (-) cable at the battery. This will prevent accidental arcing or starting.
- Keep your hands away from moving parts.
- Make sure that fasteners on the generator set are secure. Tighten supports and clamps, keep guards in position over fans, etc.
- Do not wear loose clothing or jewelry while working on generator sets, because they can become caught in moving parts. Jewelry can short out electrical contacts and cause shock or burning.
- If adjustment must be made while the unit is running, use extreme caution around hot manifolds, moving parts, etc.

GENERAL SAFETY PRECAUTIONS

- Wear safety glasses and protective clothing when servicing batteries. **DO NOT SMOKE** while servicing batteries. Lead-acid batteries emit a highly explosive hydrogen gas that can be ignited by electrical arcing or by smoking.
- Have a fire extinguisher rated ABC nearby. Maintain extinguisher properly and become familiar with its use.

- Benzene and lead, found in some gasoline, have been identified by some state and federal agencies as causing cancer or reproductive toxicity. When checking, draining or adding gasoline, take care not to ingest, breathe the fumes, or contact gasoline.
- Used engine oils have been identified by some state or federal agencies as causing cancer or reproductive toxicity. When checking or changing engine oil, take care not to ingest, breathe the fumes, or contact used oil.
- Remove all unnecessary grease and oil from the unit. Accumulated grease and oil can cause overheating and engine damage, which presents a potential fire hazard.
- Do not store anything in the generator set compartment such as oil or gas cans, oily rags, chains, wooden blocks, portable propane cylinders, etc. A fire could result or the generator set operation (cooling, noise and vibration) may be adversely affected. Keep the compartment floor clean and dry.
- Do not work on this equipment when mentally or physically fatigued, or after consuming any alcohol or drug that makes the operation of equipment unsafe.

RGA-OP1

Introduction

ABOUT THIS MANUAL

This manual covers operation and maintenance for the MicroLite™ (KY) generator set (referred to as genset). Study this manual carefully and comply with each of its warnings and cautions. The owner is responsible for maintaining the genset according to the maintenance schedule. Using the genset properly and performing regular maintenance can result in longer genset life, better performance, and safer operation.

The Operating Recommendations section covers the break-in procedure and the effects of high altitude and variations in climate. The Wattage Requirements section describes the wattage capacity of the genset and lists typical wattage use of common appliances and tools. Familiarize yourself and others who will operate this genset with this information.

MicroLite is a trademark of the Onan Corporation.

This manual also covers genset storage, basic troubleshooting, maintenance, how to obtain service, and specifications. Keep this manual and the Installation manual (981-0607) with the other vehicle manuals.

MODEL IDENTIFICATION

Always use the complete model and serial number when contacting an Onan® dealer or distributor for parts, service or product information. The model number (which includes the specification number) and the serial number are printed on the nameplate located behind the access cover (Figure 1).

To make your model and serial number easy to find when you need them, record all of the numbers that appear in the model number and serial number area on your Onan nameplate in the area provided in Figure 1. It is important to record every number and letter in order to identify the genset correctly.

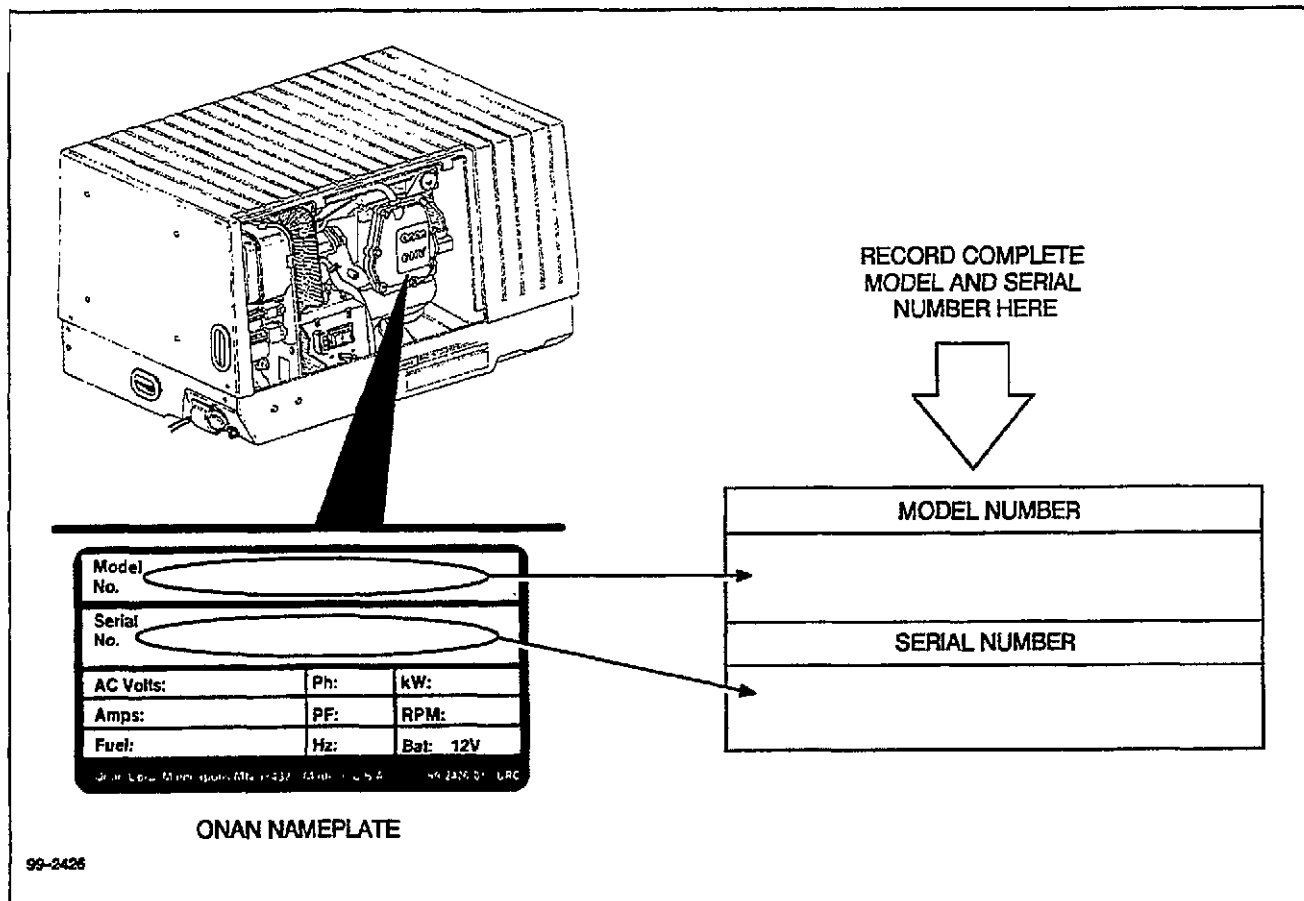

FIGURE 1. MODEL IDENTIFICATION

COMPONENT LOCATIONS

The standard control panel and routine maintenance items are located behind the access cover (Figure 2).

To remove the access cover: Rotate the latches one-quarter turn counterclockwise. Pull the top of the cover away from the housing and lift to remove.

To secure the access cover: Position the bottom of the cover over the base. Push the top of the cover in and rotate the latches one-quarter turn clockwise. Inspect the access cover to make sure it is mounted flush with the housing and secure.

⚠WARNING Operation of the genset with the access cover removed can result in severe personal injury or equipment damage. Hot components are exposed when the access cover is removed and genset cooling air does not circulate properly. Do not operate the genset with the access cover removed.

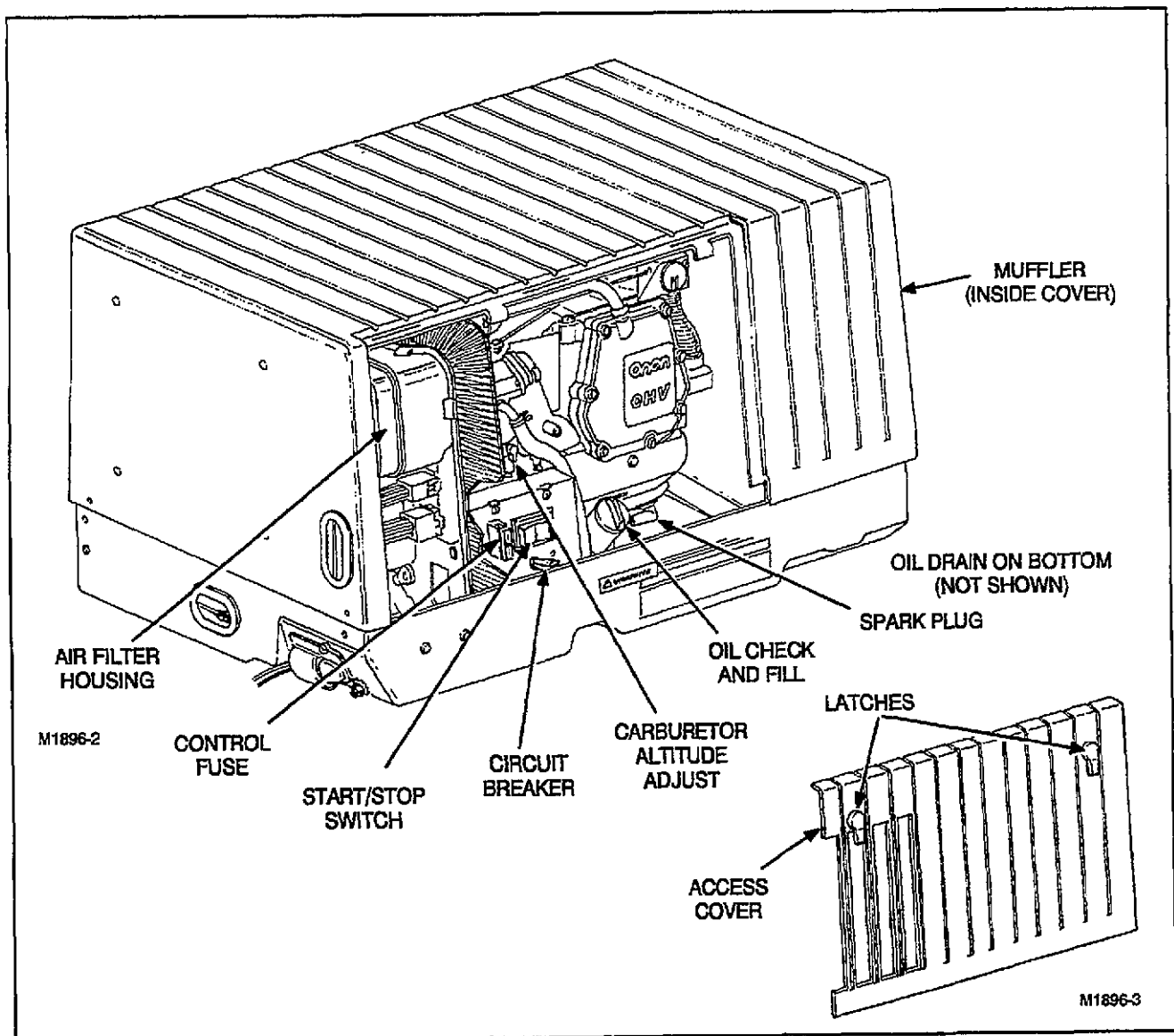

FIGURE 2. MICROLITE GENERATOR SET COMPONENT LOCATIONS

Control Panel

This section describes the features of the standard control panel and the optional remote control panel.

STANDARD CONTROL PANEL

The standard control panel is mounted behind the access cover on the genset (Figure 3). The standard control is used for starting and stopping the set from the genset compartment.

Control Component Descriptions

Start/Stop Switch: Starts and stops the genset. On 50 Hz models the start position is signified by the vertical line (I). The stop position is signified by the O. The genset can also be operated from an optional remote control (if equipped).

Control Fuse: Provides protection for the control wiring and remote wiring from a short circuit.

Line Circuit Breaker: Protects the generator from a short circuit or an overloaded circuit. If the breaker opens (trips), remove the load from the genset before resetting.

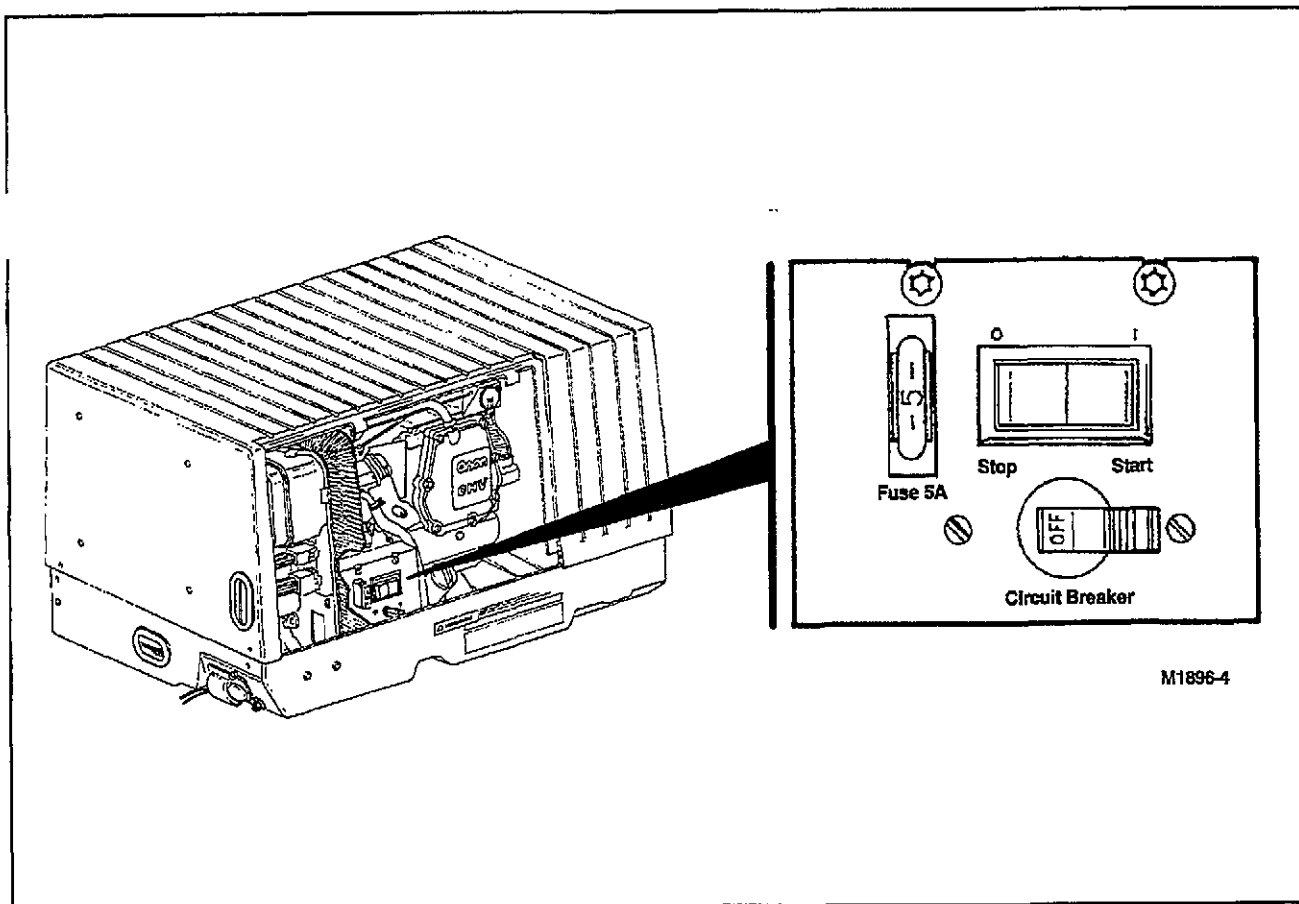

FIGURE 3. STANDARD CONTROL PANEL

REMOTE CONTROL PANEL (OPTIONAL)

An optional remote control enables the genset to be operated from inside the RV living quarters or driver's compartment. Two remote control panels are available: the Standard Remote Control and the Deluxe Remote Control (Figure 4). The control features for these two models are described below.

Standard Remote Control: This model has a Start/Stop switch with an indicator lamp that lights when the genset is running.

Deluxe Remote Control: This model has the same features as the Standard Remote Control plus a running time meter and a battery condition meter.

The running time meter indicates the total operating hours on the genset. Use this meter to keep a record of periodic maintenance.

The battery condition meter indicates the condition of the battery and the battery charging circuit. The indicator should remain in the normal zone. If it reads consistently high or low, contact an Onan service center for assistance.

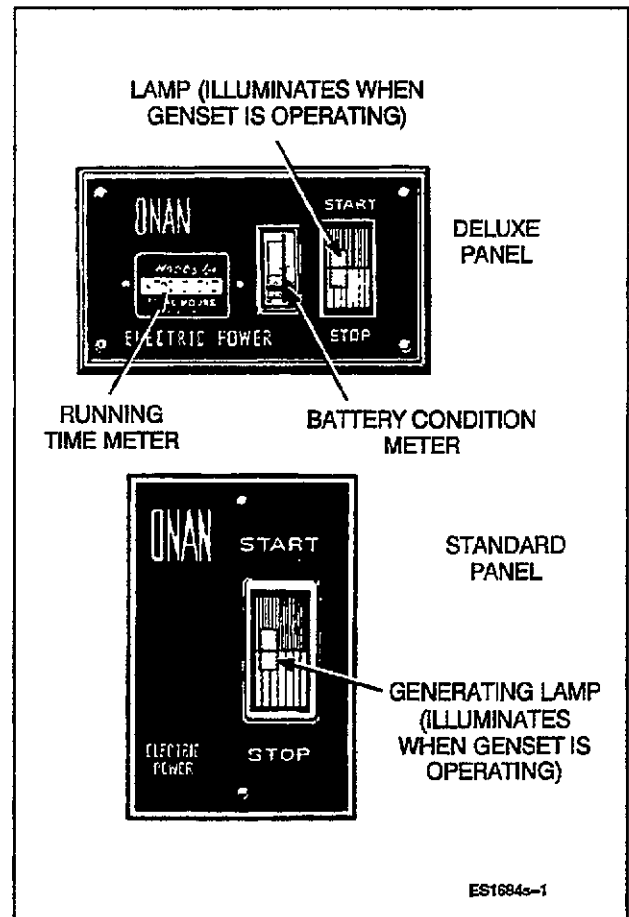

FIGURE 4. REMOTE CONTROL PANELS

Pre-Start Checks

ENGINE OIL

Check the engine oil level before each start. If adding oil between changes, use the same brand because different brands might not be compatible when mixed. Be careful not to overfill the crankcase. Overfilling will cause the oil to foam, resulting in engine shutdown.

Use premium quality motor oil with the API (American Petroleum Institute) designation SG on the container. (See page 16 for the recommended engine oil.)

Checking Engine Oil Level

Make sure that the genset is parked on a level surface and that it has cooled down. Do not check the oil level while the genset is running.

⚠ WARNING *Hot oil can cause severe personal injury. Do not check the oil level while the genset is running because hot oil could blow out of the oil fill tube causing burns.*

1. Remove the yellow oil level indicator and wipe it with a clean rag (Figure 5).
2. Insert the oil level indicator into the oil filler neck and screw it in until it is secure.
3. Remove oil level indicator and check the oil level on the indicator stem.
4. If the oil level is low, add oil very slowly until the Full mark is reached.
5. Insert the oil level indicator into the filler neck and screw it in securely to prevent oil leakage.

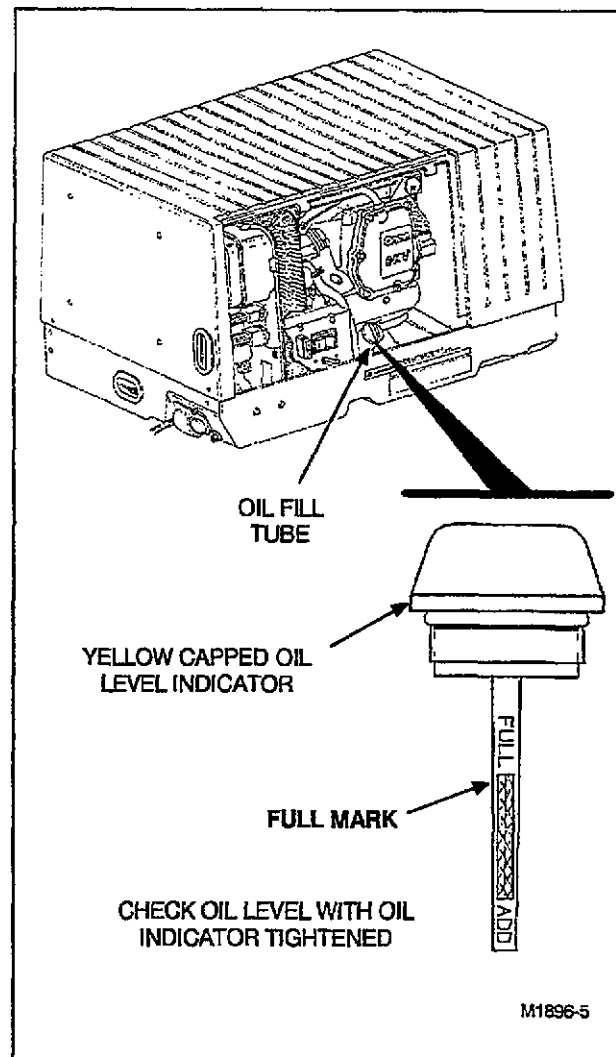

FIGURE 5. OIL LEVEL CHECK

EXHAUST CHECK

Thoroughly inspect the exhaust system for leaks or corrosion. Check the tailpipe for dents or bends. Have any problems repaired before operating the genset.

⚠ WARNING *Exhaust gas presents the hazard of severe personal injury or death. Make certain that all exhaust components are operational and that there are no exhaust leaks.*

Do not start the genset if exhaust gases will not effectively expel away from the vehicle. Be aware that any vent, window or opening that is not permanently sealed from the vehicle living space can be an avenue for carbon monoxide.

⚠ WARNING *Exhaust gases can cause severe personal injury or death. Never operate the genset unless the exhaust outlet is clear of walls, snow banks, or any obstructions that can prevent exhaust gases from dissipating. Never operate any exhaust fan in the vehicle when the genset is running: an exhaust fan can draw exhaust gas into the vehicle. The exhaust outlet must extend 1 inch (25.4 mm) beyond the perimeter of the vehicle.*

FUEL CHECK

Carefully inspect the fuel system for leaks or corrosion. Have any problems repaired immediately.

⚠ WARNING *Gasoline presents the hazard of fire or explosion that can result in severe personal injury or death. Make sure that there are no fuel leaks. Do not smoke or allow any flame, spark, pilot light, arc-producing equipment or other ignition source near the fuel system. Keep a type ABC fire extinguisher nearby.*

Make sure that the fuel tank is full and that the fuel line supply valve (if equipped) is open.

Gasoline fuels deteriorate over time causing fuel system corrosion and the formation of gum and varnish-like deposits. Fuel deposits cause hard starting and rough engine operation. If the genset will not be operated for more than 120 days, a fuel

preservative and stabilizer should be used to protect the fuel system (refer to the *Generator Set Storage* section).

Recommended Fuel

Use clean, fresh regular unleaded gasoline. Regular leaded gasoline can also be used; however, leaded gasolines cause increased engine deposits and shorter spark plug life.

Gasoline that is blended with alcohol (gasohol) can be used if it contains the correct mixtures and additives as follows:

Ethanol Blend: This fuel must not contain more than 10 percent ethanol.

Methanol Blend: This fuel must not contain more than 5 percent methanol and it must contain cosolvents and corrosion inhibitors for methanol.

LPG Models: Use clean, fresh commercial propane or HD-5 grade liquid propane gas in a mixture of at least 90 percent propane. Propane fuels other than HD-5 can contain more than 2.5 percent butane which can result in poor fuel vaporization and poor engine starting in low ambient temperatures (below 32°F or 0°C).

A manual shutoff valve must be mounted on the propane fuel supply tank. This supply tank valve must be opened fully when operating the genset so the flow valve will close with a broken propane fuel line.

GENERAL INSPECTION

Check the genset for damaged or loose parts. Make sure the air inlet and outlet areas are not blocked. Investigate any abnormal operating noises. Make sure that the genset is securely mounted in its compartment or under-floor housing.

Check to see that the vehicle is not parked in high grass or brush.

⚠ WARNING *Do not operate the genset when the vehicle is parked in high grass or brush. Hot exhaust can ignite grass or brush resulting in a fire, which can cause severe personal injury or death.*

Starting and Stopping

⚠ WARNING

EXHAUST GAS IS DEADLY!

Exhaust gases contain carbon monoxide, an odorless and colorless gas. Carbon monoxide is poisonous and can cause unconsciousness and death. Symptoms of carbon monoxide poisoning can include:

- **Dizziness**
- **Nausea**
- **Headache**
- **Weakness and Sleepiness**
- **Throbbing In Temples**
- **Muscular Twitching**
- **Vomiting**
- **Inability to Think Coherently**

IF YOU OR ANYONE ELSE EXPERIENCE ANY OF THESE SYMPTOMS, GET OUT INTO THE FRESH AIR IMMEDIATELY. If symptoms persist, seek medical attention. Shut down the unit and do not operate until it has been inspected and repaired.

Never sleep in the vehicle with the generator set running unless the vehicle interior is equipped with an operating carbon monoxide detector. Protection against carbon monoxide inhalation also includes proper exhaust system installation and visual and audible inspection of the complete exhaust system at the start of each generator set operation.

STARTING PROCEDURE

Perform each of the checks described in the *Pre-Start Checks* section before starting the genset. The genset can be started and stopped from the standard control panel on the genset or from the optional remote control panel inside the vehicle (if equipped).

Make certain that the vehicle AC distribution panel breakers are off (open). Place the output switching device on the vehicle (if present) in the "Utility" position.

⚠ CAUTION *Contact with hot engine parts can cause severe burns. Use caution when starting or stopping the genset from the standard set mounted control panel. The access cover should always be installed on the genset during operation.*

1. Turn air conditioners and large electrical loads off. Open the fuel supply valve (if equipped).
2. Hold the Start/Stop switch in the Start (I) position (Figure 6). Release the switch when the genset starts.

(On the remote control Start/Stop switch, starting is indicated by a steady glow from the lamp on the switch.)

Release the switch after 10 seconds if the engine does not start. Wait 30 seconds before repeating the start procedure.

⚠ CAUTION *Cranking the starter for longer than 10 seconds can overheat and damage the starter. If the engine does not start after 10 seconds, release the Start/Stop switch and wait 30 seconds before repeating the start procedure.*

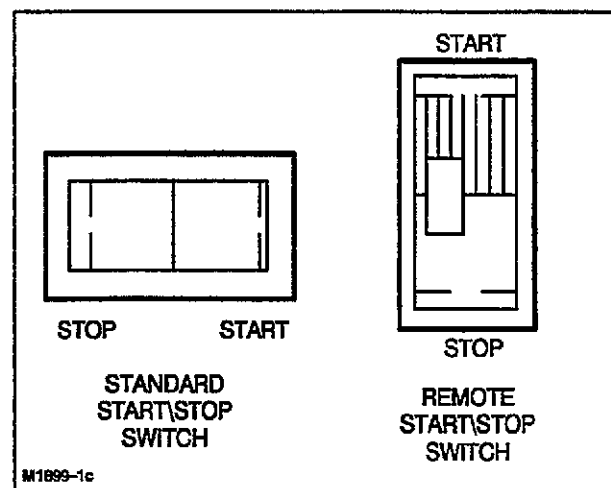

FIGURE 6. START/STOP SWITCH

-
3. Let the genset warm up for a few minutes before connecting a load. Make sure that the genset is running smoothly and that there are no fuel or exhaust leaks.

See the *Wattage Requirements* section to determine how much wattage (load) can be used with the genset.

If the engine stops running shortly after starting, check to see if the oil level is too high or too low. Make sure that the access cover is securely installed during operation.

Refer to the *Troubleshooting* section if starting problems persist.

STOPPING

1. Turn off air conditioners and large electrical loads before stopping to allow the genset time to cool down.
2. Let the genset run three to five minutes. Failure to let the genset cool down can cause engine run-on or backfire.
3. Push the Start/Stop switch to the Stop (O) position.

If the genset can be started or stopped from the genset but not from the remote control, contact an Onan service center for assistance. Refer to the *How to Obtain Service* section.

Wattage Requirements

AC WATTAGE CAPACITY

The 120-volt AC power output (60Hz models) from the generator can be used to power appliances and other electrical equipment. (Appliances and other electrical equipment are referred to as “electrical loads” or “loads” when they are connected to the generator.)

A 30-amp circuit breaker, on the standard set mounted control panel, protects the wiring from damage due to an overloaded circuit. An overloaded circuit occurs when too many appliances, tools, lights, etc., are operated at the same time.

The 30-amp circuit breaker on the genset is used to match the 30-amp breaker that is on the shore power. The breaker limits the total amount of continuous load to 3,600 watts.

Connecting a Load

To determine the maximum amount of electrical appliances or loads that can be used at one time, follow these steps:

1. Determine the maximum amount of wattage that can be used with the 30-amp vehicle circuit. Maximum load (wattage) is obtained by multiplying the circuit breaker size times the AC output voltage:

$$30\text{-Amp Breaker} \times 120\text{V} = 3600 \text{ Watts}$$

2. Check the wattage usage of each item that you plan to connect to the genset. Table 1 lists typical wattages for common electrical appliances. Look at the appliance nameplate to obtain the actual wattage for each item.
3. Add the wattages of all the items to be operated at the same time. Make sure that the total wattage does not exceed the limit of the vehicle circuit breaker (3600 watts).

Example: In our example we will use a 13,500 BTU air conditioner with a nameplate wattage of 1,800. In addition, a few common appliances are used.

Air Conditioner	1800 Watts
Converter	500 Watts
Coffee Percolator	600 Watts
Television	300 Watts
Total	3200 Watts

4. Start the genset and allow it to warm up for a few minutes before adding electrical loads.

Make sure that each of the appliances and tools are properly grounded and that they are in good working condition before using them.

⚠ WARNING *Electrical shock can cause severe personal injury or death. Appliances should be in good working condition and be properly grounded to provide additional protection from electrical shock.*

TABLE 1. APPROXIMATE POWER USAGE OF COMMON APPLIANCES

Appliance or Tool	Approximate Wattage Usage
Air Conditioner	1600-2000
Battery Charger	Up to 800
Coffee Percolator	550-750
Converter	300-500
Electric Blanket	50-200
Electric Broom	200-500
Electric Drill	250-750
Electric Frying Pan or Wok . . .	1000-1500
Electric Iron	500-1200
Electric Stove (Per Element) . .	350-1000
Electric Water Heater	1000-1500
Hair Dryer	800-1500
Microwave Oven	1000-1500
Radio	50-200
Refrigerator	600-1000
Space Heater	1000-1500
Television	200-600

See text for starting appliances with motors

Appliances with Motors

Appliances with motors consume more current during start-up than they do when they are operating at normal speed. (Some motors draw up to three times their operating current during start-up.) If you plan to use an appliance with a motor (such as an air conditioner or refrigerator), turn it on before starting other appliances. Once the motor is running at normal speed, additional appliances can be added.

Circuit Breakers

Circuit breakers on the electrical distribution panel or on the genset will trip (open) if their current ratings are exceeded. This can be caused by using too many appliances at one time or by a short in the electrical circuit.

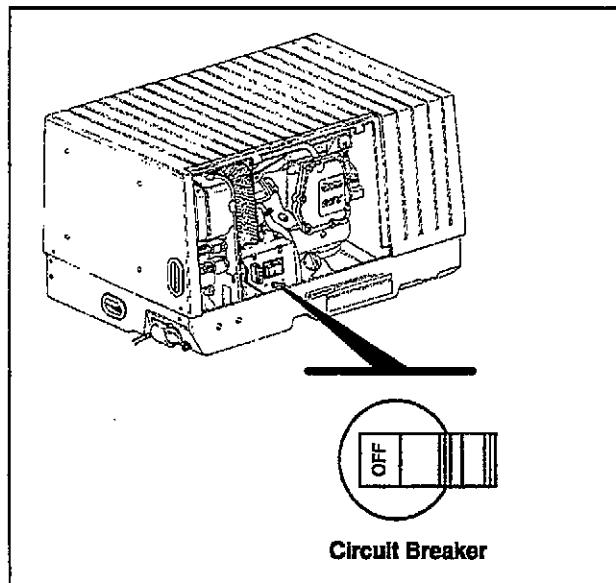

FIGURE 7. SET MOUNTED CIRCUIT BREAKER

The genset will continue to run after a circuit breaker trips. Turn off all of the appliances and other electrical loads, then reset the breaker (Figure 7). If the circuit breaker trips again, a short circuit in the wiring is indicated. Turn off the genset and contact a qualified electrician for assistance.

If the circuit breaker does not trip, turn on only as many appliances as the circuit breaker size will allow (see *Connecting a Load* in this section). If the

circuit breaker trips again, a defective appliance or circuit breaker is indicated.

Connection to Utility Power

Connect utility power (power from a commercial source such as a plug-in outlet) only through an approved device to protect against the possibility of generator power connecting to the utility power.

WARNING *Connecting the genset directly to the public utility or any other power system can cause electrocution, damage to equipment, or fire. Hazardous voltages can flow from the genset into the utility line. An approved switching device must be used to prevent interconnections.*

High Altitude Operation

Operating the genset at a high altitude will lower the output power of the genset and decrease fuel efficiency. Refer to the *Operating Recommendations* section for high altitude carburetor adjustments.

Maximum power decreases about 3.5 percent for each 1,000 feet (305 m) above the rated altitude of 500 feet (152 m). When operating the genset at an altitude above 500 feet, calculate the loss of power to determine maximum power capacity.

Example: Operation at 4,500 feet (1371 m), or 4,000 (1,219 m) feet above the rated altitude will result in a power loss of 14 percent or 560 watts: $0.14 \times 4,000 \text{ watts (set rated power)} = 560 \text{ watts}$. Subtract 560 watts from the set rated power of 4,000 watts and the maximum power at 4,500 feet is 3,440 watts.

DC POWER (50 HZ MODELS ONLY)

A 12-volt DC output (10 ampere maximum) on the 50 Hz models, is used to charge the genset starting battery.

On 60 Hz models the battery is normally charged by the converter/charger in the vehicle. The battery is charged by the converter/charger when the genset is running or when the vehicle is plugged into utility power.

Operating Recommendations

BREAK-IN PROCEDURE

Performing the following break-in procedure will prevent glazing of the engine cylinder and high oil consumption.

1. Start the genset and apply a load of 50 percent of its wattage capacity (1800 watts or one air conditioner). Run the genset with this load for two hours. Refer to Table 1 for the wattage usage of common appliances and tools.
2. Increase the wattage load to 75 percent capacity (2700 watts or one air conditioner and an additional load of 900 watts) and run the genset for another two hours.
3. Disconnect the load and allow the genset to run for 3 minutes, to cool down the genset before stopping.
4. Change the engine crankcase oil after the first 20 hours of operation, and every 150 hours after that.

OPERATING IN HOT OR COLD WEATHER

Hot Weather

Make certain that nothing blocks the airflow to and from the genset. See that the genset is maintained according to the *Maintenance Schedule* and keep the engine clean.

Cold Weather

Use the correct oil weight for cold weather conditions. See the *Recommended Engine Oil* section for oil recommendations. Change the oil after the engine has been warmed up. If a sudden temperature change occurs and the oil is not the correct weight, change the oil.

HIGH ALTITUDE

Performance will decrease and fuel consumption will increase at high altitudes due to a rich air-fuel mixture. If operation is inhibited by high altitude on gasoline fueled sets (above 2000 feet or 610 m), adjust the carburetor main fuel adjustment limiter cap for a slightly leaner fuel mixture. See Figure 8. Return the adjustment screw to the original setting before operating the genset at lower altitudes, or performance problems can occur due to a lean air-fuel mixture.

CAUTION Operating the genset with a lean air-fuel setting at low altitudes can cause power loss, overheating and engine damage. Return the carburetor main fuel adjustment to its original setting before operating the genset at low altitudes.

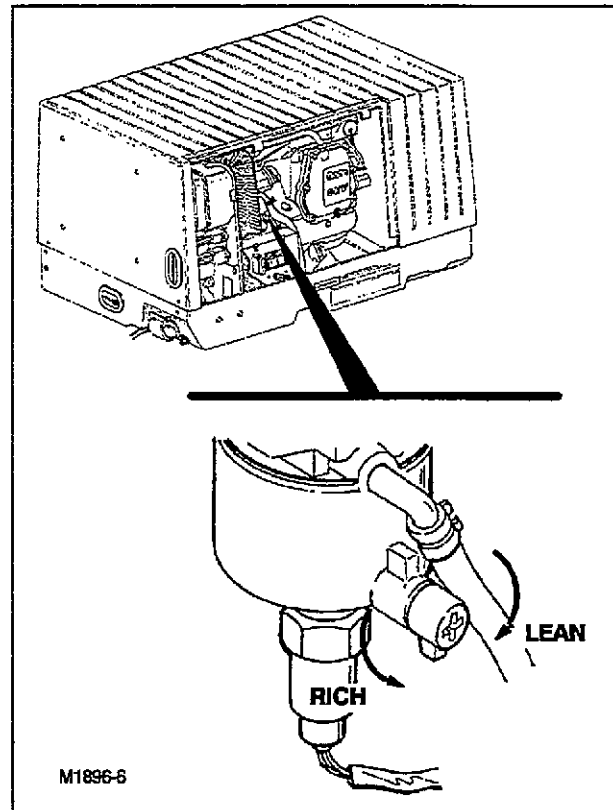

FIGURE 8. CARBURETOR ALTITUDE ADJUSTMENT

OPERATING IN DUSTY CONDITIONS

1. Keep the genset and its cooling surfaces as clean as possible.
2. Service the air cleaner frequently.
3. Increase the engine crankcase oil change interval to every 50 operating hours.
4. Keep oil in a dust-tight container.

GENERATOR SET EXERCISE

Infrequent operation of the genset can allow harmful moisture to condense in the engine. Moisture accumulates because the engine does not run often enough to reach normal operating temperature. Also fuel in the carburetor will evaporate and leave deposits that can cause hard starting and unstable running.

To prevent harmful moisture accumulation and fuel deposits, run the genset at 50 percent capacity (1800 watts or one air conditioner) for two hours every four weeks. A long exercise period is preferable to several short periods.

Maintenance Schedule

Following the maintenance schedule and using the genset properly will result in longer genset life, better performance, and safer operation. Perform each maintenance procedure at the time period indicated or after the number of operating hours indicated, whichever comes first. Refer to the following *Maintenance Procedures* section for instructions.

Consult an Onan[®] service center if the genset will be subjected to extremely hot or dusty conditions to

develop a more frequent maintenance schedule. Log all service and maintenance for warranty support (see the *Maintenance Record* section).

⚠ WARNING *Accidental starting of the genset during maintenance can cause severe personal injury or death. Disconnect both genset starting battery cables, before performing maintenance. Remove the negative (-) cable first to reduce the risk of arcing.*

TABLE 2. PERIODIC MAINTENANCE SCHEDULE

SERVICE THESE ITEMS	SERVICE TIME				
	Daily or Every 8 hours	Every 150 Hours	Every 250 Hours	Every 500 Hours	P A G E
Inspect Set	x ¹				14
Check Oil Level	x				5
Change Crankcase Oil		x ²			15
Clean Spark Arrester		x ³			19
Clean and Check Battery		x			17
Replace Air Filter			x ⁴		18
Clean or Replace Spark Plug				x ⁵	19
Check Valve Lash Clearance				x ⁶	—
Change Fuel Filter				x ⁶	—
Clean and Adjust Carburetor and Governor				x ⁶	—
Inspect and Leak Test the LPG System				x ⁶	—

1. Check for oil, fuel and exhaust system leaks. Check exhaust system audibly and visually with the genset running. Temporarily remove the access cover to check muffler. Shut off the genset and repair any leaks immediately. Replace corroded exhaust and fuel line components before leaks occur.
2. Perform after first 20 hours of operation on new gensets.
3. Clean spark arrester every 50 hours.
4. Replace more often in dusty conditions.
5. Service sooner if performance problems occur.
6. Have the Onan service center perform.

Maintenance Procedures

GENERAL INSPECTION

Inspect the genset daily or after every eight hours of operation, whichever comes first. Perform the following exhaust, fuel, and electrical systems checks. Also check the mechanical condition of the genset.

Exhaust System

Examine the exhaust system for leaks. Inspect the genset compartment for holes that might allow exhaust gas to enter the vehicle. If the genset compartment has holes to the interior of the vehicle or if the genset runs louder than usual or has an exhaust system leak, do not operate the genset until the problem is corrected. Also check to make sure that the tailpipe extends 1 inch (25.4 mm) beyond the perimeter of the vehicle.

Replace worn, damaged, or corroded exhaust components before leaks occur.

⚠WARNING *Exhaust gas presents the hazard of severe personal injury or death. If there are any exhaust leaks, do not operate the genset, and have the exhaust system repaired before using the genset.*

Fuel System

With the genset running, check the fuel supply line, filter, and fittings for leaks. Check flexible section for cuts, cracks, or abrasions, and make sure the fuel line does not rub against anything. Replace worn or hardened fuel line components before leaks occur.

⚠WARNING *Fuel presents the hazard of fire or explosion that can result in severe personal injury or death. If any leaks are detected, have them corrected immediately.*

DC Electrical System

With the genset off, check the battery terminals for clean and tight connections. Loose or corroded connections create resistance that can impede starting. Clean and reconnect loose battery cables. Remove the negative (–) battery cable first and install it last to reduce the risk of arcing.

⚠WARNING *Batteries present the hazard of explosion that can result in severe personal injury. Do not smoke or allow any flame, spark, pilot light, arc-producing equipment or other ignition sources around the battery area. Do not disconnect battery cables while the genset is cranking or running because explosive battery gases could be ignited.*

Mechanical

Check for any signs of mechanical damage. Start the genset and listen for any unusual noises that may indicate mechanical problems. Have any problems corrected immediately.

Check the mounting fasteners to make sure the genset is secure in its compartment. If an under-floor housing is used, make sure that the genset is secured to the housing. Check the condition of the housing components and make sure they are secure to the vehicle.

Make sure that the genset air inlet and outlet areas are not blocked with debris.

Clean the genset whenever dust and dirt begin to accumulate. Dust and dirt can usually be removed with a damp cloth. Steam cleaning may be needed to remove road contaminants. Do not clean the genset while the engine is running. Protect the generator, air cleaner, control panel, and electrical connections from cleaning solvents. Cleaning solvents can damage electrical connectors.

OIL CHANGE

In dusty or dirty conditions, change the oil more frequently than the interval specified in the maintenance schedule. Figure 9 shows the location of the oil drain, oil filler neck and oil level indicator.

⚠WARNING *Hot oil can cause severe burns if spilled or splashed on skin. Keep fingers and hands clear when removing oil drain plug, and wear protective clothing.*

1. Place a pan under the oil drain plug. Run the engine until it is warm, then shut it off.
2. Remove the yellow oil level indicator.
3. Remove the yellow oil drain hole cover located on the bottom of the genset. Unscrew the oil plug and allow all of the oil to drain from the engine.
4. Install the oil plug and tighten it securely to prevent an oil leak.
5. Use a premium quality motor oil. The engine oil capacity is 1.6 quarts (1.5 litres). See the following Recommended Engine Oil section to select the proper weight oil.
6. Pour the oil into oil filler neck slowly. Check the oil level by inserting oil level indicator into filler neck. Screw the oil level indicator in securely to obtain an oil level reading. Add oil until the full mark is reached.
7. Insert the oil level indicator in the fill tube and screw it in securely to prevent oil leakage. Check the oil drain plug area for leaks. Reinstall the yellow oil drain hole cover.

Used oil is harmful to the environment. Pour used oil into a sealed container and deliver it to the nearest recycling center or automotive service station.

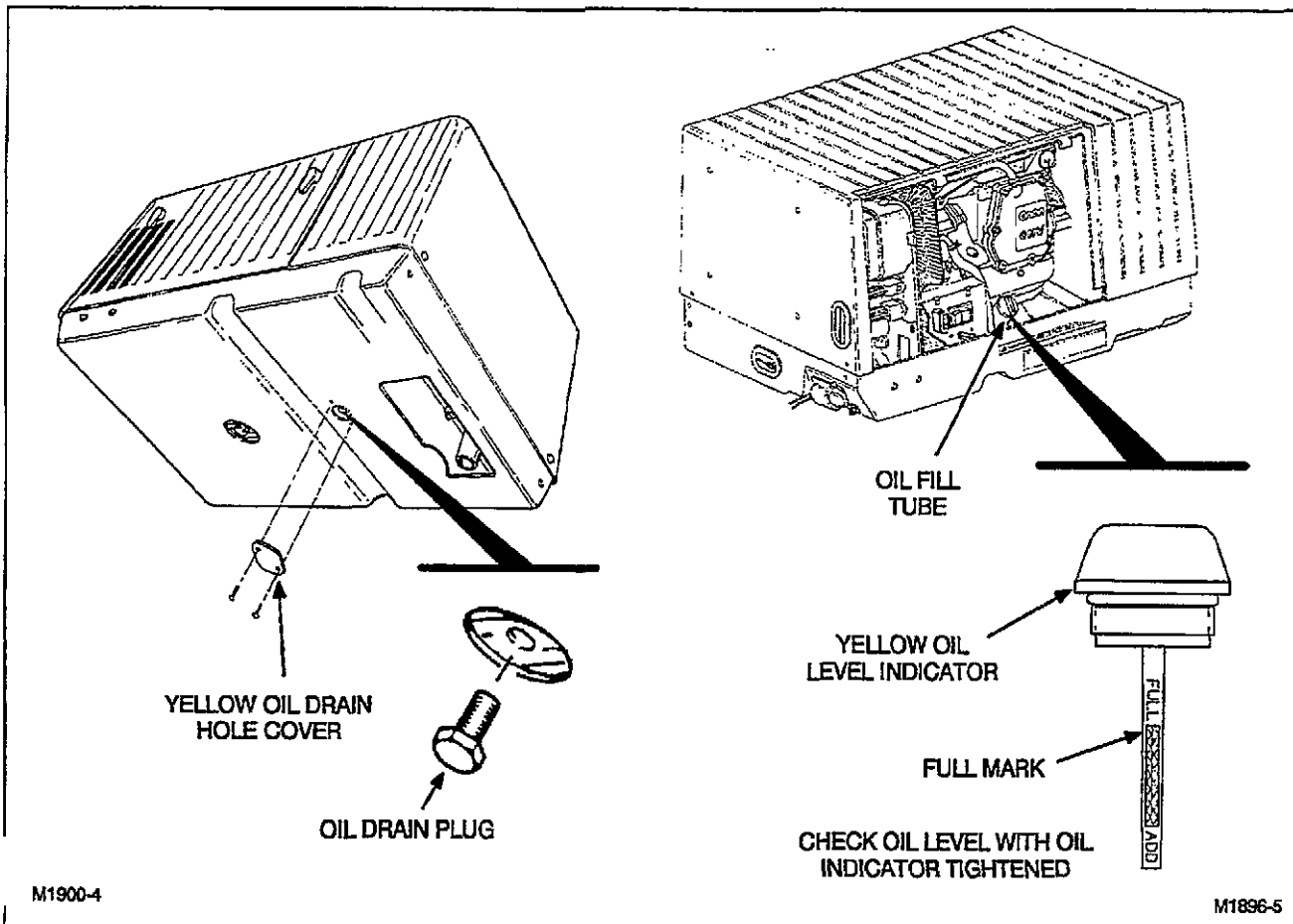

FIGURE 9. OIL CHANGE

Recommended Engine Oil

Use premium quality motor oil with the API (American Petroleum Institute) designation SG on the container. Figure 10 shows the recommended oil weight for the temperature range that the genset will be operated in. Make sure the engine oil weight will be correct for the expected temperature range.

The engine oil capacity is 1.6 quarts (1.5 litres).

Single-grade oil is preferable when temperatures are consistently over 30°F (0°C). Multigrade oils are best when wide temperature variations are anticipated.

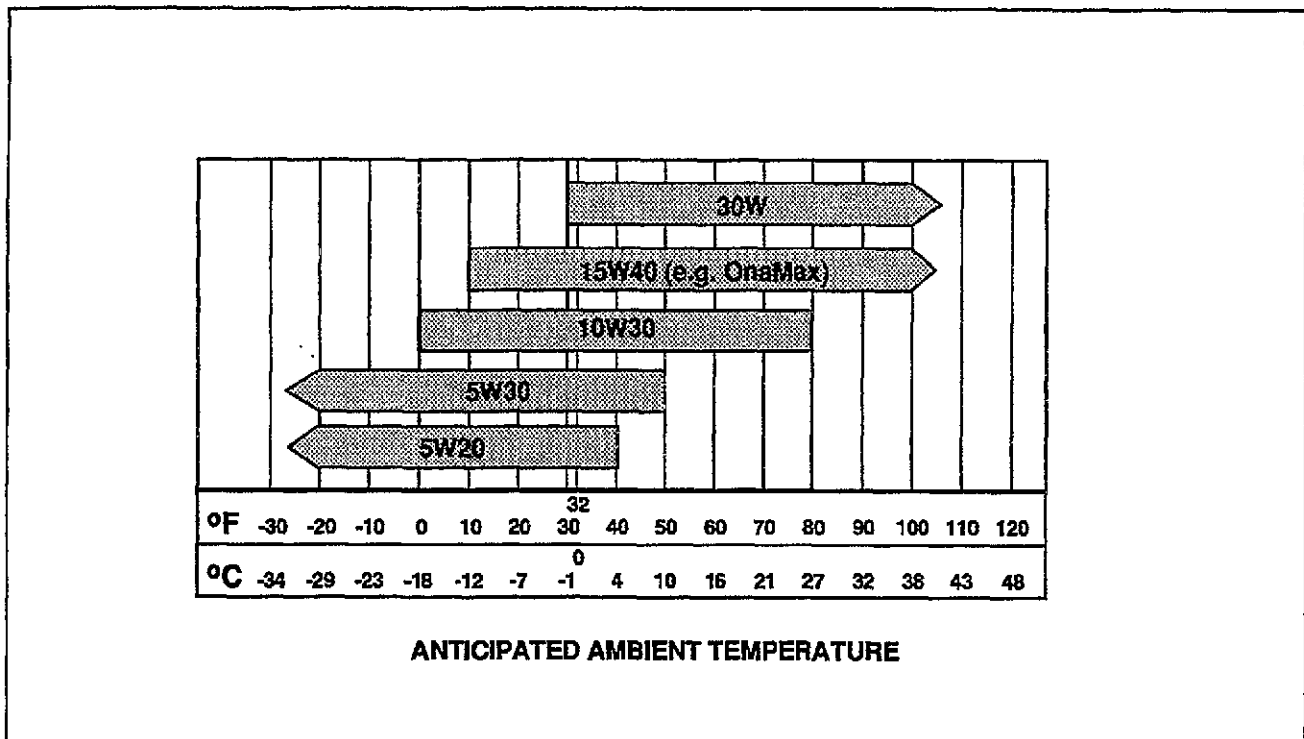

FIGURE 10. OIL VISCOSITY VS. TEMPERATURE

BATTERY CARE

Service the battery at the intervals shown in the maintenance schedule. Check the electrolyte level more frequently during hot weather.

⚠WARNING Batteries present the hazard of explosion that can result in severe personal injury. Do not smoke or allow any flame, spark, pilot light, arc-producing equipment or other ignition sources around the battery area. Do not disconnect battery cables while the genset is cranking or running because explosive battery gases could be ignited.

⚠WARNING Battery electrolyte can cause severe eye damage and burns to the skin. Wear goggles, rubber gloves and a protective apron when working with batteries.

1. Keep the battery case clean and dry.
2. Make certain that the battery cable connections are clean and tight. Use a terminal puller tool to remove the battery cables.
3. Identify the cable as positive (+) or negative (-) before making the battery connections. Always connect the negative (-) cable last, to reduce the risk of arcing.
4. To remove corrosion from the battery terminals, wash the terminals with an ammonia solution or a solution consisting of 1/4 pound (about 100 grams) of baking soda in 1 quart (about 1 liter) of water. Be sure the vent plugs are tight to prevent cleaning solution from entering the cells. After cleaning, flush the outside of the battery and the surrounding areas with clean water.

5. Maintain the electrolyte level by adding distilled water. Fill each cell to the split-level marker in the battery. The water component of the electrolyte evaporates, but the sulfuric acid component remains. For this reason, add water, not electrolyte to the battery.
6. Use a battery hydrometer to check the specific gravity of the electrolyte in each battery cell (Figure 11). Charge the battery if the specific gravity measures less than 1.215. Do not overcharge the battery. Stop charging the battery when the electrolyte specific gravity reaches 1.260, at approximately 80° F (27° C).

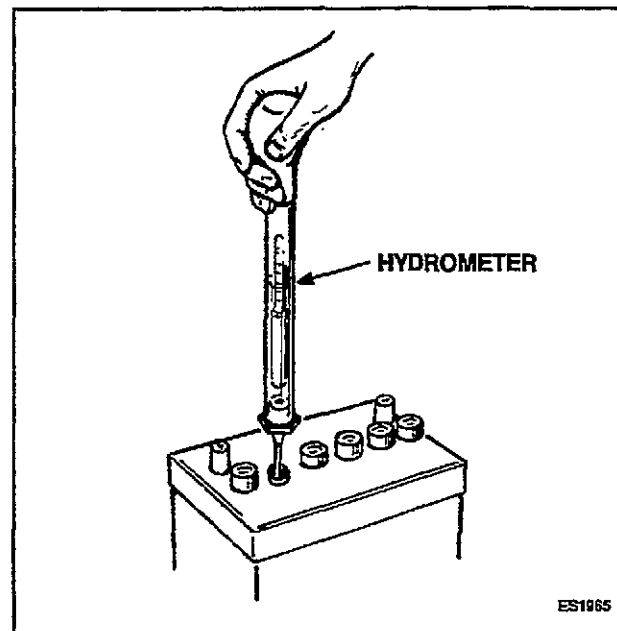

FIGURE 11. BATTERY CHECK

AIR FILTER REPLACEMENT

In dusty conditions, change the air filter more frequently to prevent equipment damage. Use only genuine Onan replacement filters.

CAUTION *Incorrect replacement of service parts can result in damage to equipment. Use only genuine Onan replacement air filters.*

Contact the nearest Onan dealer or distributor for replacement filters. Change the air filter as follows:

1. Remove the foam block from the left side of the genset housing as shown in Figure 12 (used on 60 Hz models only).

2. Remove the wing nut from the end of the air filter housing. Remove the air filter housing cover.
3. Remove the wing nut retaining the air filter plate. Remove the plate and the filter.
4. Replace the air filter, reinstall the filter end plate and secure with the wing nut. Check to make sure the air filter is centered around the carburetor air inlet.
5. Install the air filter housing cover and secure it with the wing nut. Do not over-tighten the wing nut or the housing cover will become distorted.
6. Reinstall the foam block (60 Hz models only).

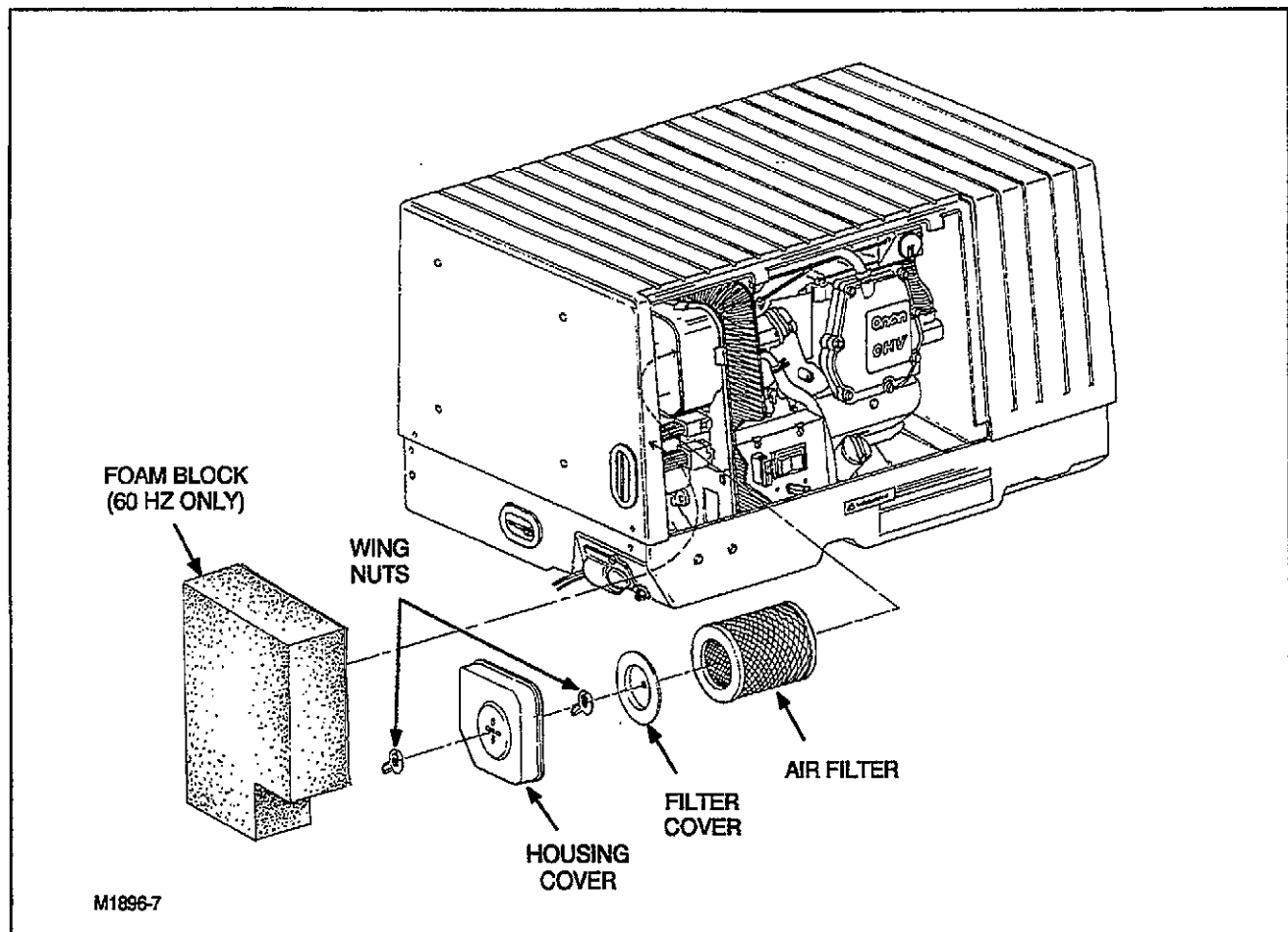

FIGURE 12. REPLACING THE AIR FILTER

SPARK PLUG

The genset has one spark plug. The plug must be in good condition for proper engine starting and performance. A spark plug with heavy combustion deposits can cause the engine to misfire, operate erratically, or stop when a load is applied.

The spark plug can be removed through the access cover (Figure 13). Inspect and regap the plug. Replace the spark plug if it is discolored or fouled.

- Black deposits indicate a rich mixture.
- A wet plug indicates misfiring.
- A badly or frequently fouled plug indicates the need for a major tune-up.

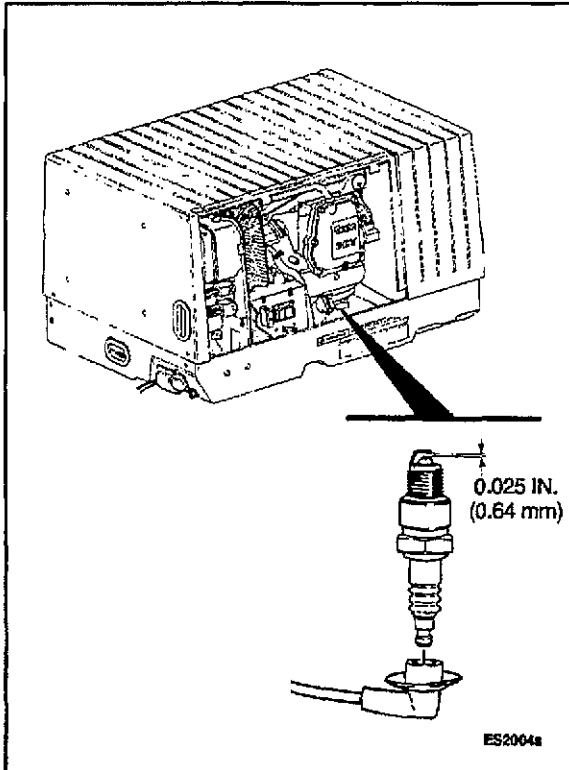

FIGURE 13. SETTING SPARK PLUG GAP

SPARK ARRESTER SERVICE

WARNING A hot exhaust system can cause severe burns. Allow the genset to cool down before servicing the muffler.

The spark arrester requires periodic cleaning for maximum genset performance and to meet USDA requirements.

Spark Arrester Cleaning Procedure:

1. Remove the 3/8 inch pipe plugs from the bottom of the muffler (Figure 14).
2. Operate the genset with a load applied for five minutes.
3. Stop the genset and allow the muffler to cool down.
4. Reinstall the 3/8-inch pipe plugs.

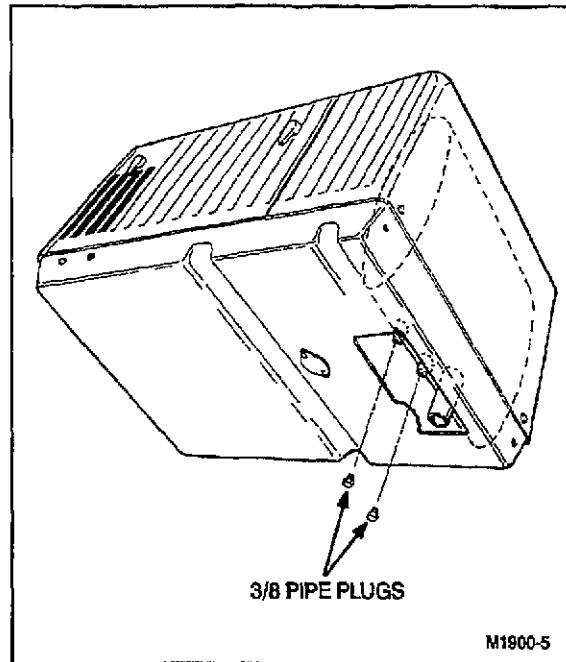

FIGURE 14. SPARK ARRESTER CLEANING

Generator Set Storage

Perform the storage procedure if the genset cannot be exercised regularly and will not be in use for more than 120 days. Failure to provide out-of-service protection can result in difficult starting, rough engine operation and reduced engine life.

Generator Set Storage Procedure

1. Add a fuel preservative and stabilizer, such as OnaFresh™, to the fuel supply. Follow the label instructions for using the fuel additive. Run the genset at 50 percent load (1800 watts) for 30 minutes.

⚠ WARNING *Fuel additives can cause a risk of personal injury or death. Fuel additives are caustic and flammable, read and carefully follow manufacturer's instructions.*

2. Disconnect the load, switch AC breaker OFF (Figure 3-1) and stop the genset from the set control panel.
3. Close the fuel supply valve (if equipped) or remove and plug the fuel line. Remove the air filter. Restart the genset at the set control. As the genset starts to run out of fuel (noticeable stumble or surge), spray a fogger, such as OnaGard™, into the carburetor intake. Follow the label instructions for using the fogger.

⚠ WARNING *Fuel presents the hazard of fire or explosion that can cause severe personal injury or death. Do not permit any flame, spark, pilot light, lit cigarette, or other ignition source near the fuel system. Keep a type ABC fire extinguisher nearby.*

4. When the engine stops, reassemble the air filter and housing to the genset. Replace the air filter if it is dirty.
5. Drain the crankcase oil when the genset has cooled (see Oil Change in the *Maintenance Procedures* section). Refill the crankcase and attach a tag indicating oil weight.

OnaFresh and OnaGard are trademarks of Onan Corporation.

⚠ WARNING *Hot oil can cause severe burns if spilled or splashed on skin. Wear protective clothing. Keep fingers and hands clear when removing oil drain plug.*

6. Disconnect the cables from the starting battery. Remove the negative (-) cable first to reduce the risk of arcing.

Returning the Generator Set to Operation

1. Inspect the genset (see *Maintenance Procedures*).
2. Check the engine oil level. Check tag on genset to verify that oil weight is still correct for the existing temperature range.
3. Clean and check the battery. Measure the specific gravity and verify that the electrolyte level is filled up to the split ring. Reconnect the battery cables. Connect the negative (-) cable last to reduce the risk of arcing.

⚠ WARNING *Battery electrolyte can cause severe eye damage and burns to the skin. Wear goggles, rubber gloves, and a protective apron when working with batteries.*

⚠ WARNING *Batteries present the hazard of explosion that can result in severe personal injury. Do not smoke or allow any spark, flame, pilot light, arc-producing equipment or other ignition sources around the battery area.*

4. Open the fuel supply valve (if equipped) or unplug and reconnect the fuel line.
5. Start the genset from the set mounted control. Initial startup may be slow, due to oil in the cylinder. Smoke and rough operation will occur until the oil in the cylinder is burned off. If the engine does not start, clean or replace the spark plug.

Troubleshooting

The following chart is a basic troubleshooting guide. If these recommendations fail to resolve the problem, contact an authorized Onan service center.

⚠WARNING *Many troubleshooting procedures present hazards that can result in severe personal injury or death. Only qualified service personnel with knowledge of fuels, electricity, and machinery hazards should perform service procedures. Review safety precautions on pages ii and iii.*

⚠WARNING *A hot genset can cause severe burns. Always allow the genset to cool down before performing any maintenance or service procedures.*

TABLE 3. TROUBLESHOOTING GUIDE

Problem	Probable Cause	Solution
FAILS TO CRANK	<ol style="list-style-type: none"> 1. Low battery. 2. Bad battery connection. 3. Blown fuse. 	<ol style="list-style-type: none"> 1. Check battery electrolyte level. 2. Clean and tighten all battery and cable connections. 3. Replace fuse on control panel.
CRANKS SLOWLY	<ol style="list-style-type: none"> 1. Low battery. 2. Bad battery connection. 3. Oil is too heavy. 4. Load connected. 	<ol style="list-style-type: none"> 1. Check battery electrolyte level. 2. Clean and tighten all battery and cable connections. 3. Replace with lighter oil. 4. Disconnect load while starting.
CRANKS BUT WON'T START	<ol style="list-style-type: none"> 1. Fuel below genset pickup level in tank. 2. Fuel supply shutoff valve closed. 3. Carbon deposits on spark plug. 4. Low oil level. 	<ol style="list-style-type: none"> 1. Add fuel. 2. Fully open fuel supply valve. 3. Remove spark plug and clean. 4. Add oil if necessary.
EXHAUSTING BLACK SMOKE	<ol style="list-style-type: none"> 1. Rich fuel mixture. 2. Dirty air filter. 3. Choke stuck or misadjusted. 	<ol style="list-style-type: none"> 1. Turn main fuel adjustment in (cw) 1/8 turn (location of adjustment is shown in Figure 8, page 11). 2. Replace air filter. 3. Contact an Onan service center.
UNIT RUNS THEN STOPS OR STOPS WHEN DRIVING AROUND A CORNER	<ol style="list-style-type: none"> 1. Low on fuel. 2. Low oil level. 3. Excess oil. 	<ol style="list-style-type: none"> 1. Refill fuel tank. 2. Add oil if necessary. 3. Reduce engine oil level.
UNIT RUNS THEN SURGES	<ol style="list-style-type: none"> 1. Loose or worn spark plug lead. 2. Ignition coil, wiring, or control components defective. 3. Faulty spark plug. 4. Governor out of adjustment. 5. Combustion air preheat malfunction. 6. Carburetor icing. 	<ol style="list-style-type: none"> 1. Check security of spark plug lead at spark plug and ignition coil. 2. Contact an Onan service center. 3. Remove and clean or replace 4. Contact an Onan service center. 5. Contact an Onan service center. 6. Stop the genset and move the carburetor throttle to free it.
CIRCUIT BREAKER TRIPS (GENSET CONTINUES TO OPERATE)	<ol style="list-style-type: none"> 1. Overloaded circuit. 2. Hot weather increasing load. 	<ol style="list-style-type: none"> 1. Remove a portion of the load. 2. Air conditioners and other appliances consume more power in hot weather, remove some of the load.

How to Obtain Service

LOCATING SERVICE ASSISTANCE

When your genset needs parts or service, contact the nearest authorized dealer or distributor. Onan Parts and Service representatives are factory-trained to handle all of your service needs. Locate the nearest authorized distributor as follows:

1. Check the North American Sales and Service Directory (F-118) supplied with your Onan RV genset. This directory lists authorized distributors who will assist you in locating the nearest authorized dealer.

-OR-

2. Consult the Yellow Pages. Typically, our distributors are listed under:

GENERATORS-ELECTRIC,
ENGINES-GASOLINE OR DIESEL, OR
RECREATIONAL VEHICLES-EQUIPMENT,
PARTS AND SERVICE.

-OR-

3. For the name of your local Cummins/Onan or Onan-only distributor in the United States or Canada, call 1-800-888-ONAN (this automated service utilizes touch-tone phones only). By entering your area code and the first three digits of your local telephone number, you will receive the name and telephone number of the distributor nearest you.

If you need additional assistance, please call Onan Corporation, 1-612-574-5000, 7:30 AM to 4:00 PM, Central Standard Time, Monday through Friday.

You can obtain an individual directory of authorized RV servicing dealers by calling Onan at 1-800-888-ONAN or by writing to Onan ("Attn: Marketing") at the address listed on the rear cover. Please ask for: RV Sales and Service Directory F-919.

SCHEDULING SERVICE

1. Before calling for service, have the following information available:

The complete Onan product model number and serial number (see Model Identification on page 1)

Date of purchase

Nature of the problem

2. Contact the authorized dealer or distributor nearest you to explain the problem and make an appointment.
3. If you have difficulty in arranging for service or resolving a problem, please contact the dealer coordinator or service manager at the nearest Cummins/Onan distributor for assistance.

⚠ WARNING

INCORRECT SERVICE OR PARTS REPLACEMENT CAN RESULT IN SEVERE PERSONAL INJURY, DEATH, AND/OR EQUIPMENT DAMAGE. SERVICE PERSONNEL MUST BE QUALIFIED TO PERFORM ELECTRICAL AND/OR MECHANICAL SERVICE.

Specifications

60 HERTZ MODELS	4000 KY	3600 KY (LP)
GENERATOR		
Generator Type	Onan, Revolving Field, 2-Pole	Onan, Revolving Field, 2-Pole
Frequency (Hertz)	60	60
Power (Watts)	4000	3600
Voltage	120 (100*)	120
Current (Amperes)	33.3 (40*)	30
ENGINE		
Engine Model	Onan EO95H-G	Onan EO95H-G
Engine Type	4-Stroke, Single Cylinder, OHV	4-Stroke, Single Cylinder, OHV
Engine Speed	3600 rpm	3600 rpm
Ignition Type	Electronic Magneto (Breakerless)	Electronic Magneto (Breakerless)
Fuel	Gasoline	LPG Vapor (11 inches W.C.)
Engine Oil Capacity	1.6 qt (1.5 L)	1.6 qt (1.5 L)
Battery Requirements:		
Battery Voltage	12-Volt	12-Volt
Cold Cranking Amps	360 (450 Below 32°F [0°C])	360 (450 Below 32°F [0°C])
Spark Plug Gap	0.025 in. (0.64 mm)	0.025 in. (0.64 mm)
Average Fuel Consumption:		
No Load	0.15 gph (0.57 L/h)	1.5 lbs/h (0.68 kg/h)
Half Load	0.40 gph (1.51 L/h)	2.72 lbs/h (1.23 kg/h)
Full Load	0.66 gph (2.5 L/h)	3.5 lbs/h (1.59 kg/h)
GENERATOR SET DETAILS		
Dimensions:		
Length	30 in. (762 mm)	30 in. (762 mm)
Width	19.68 in. (499.9 mm)	19.68 in. (499.9 mm)
Height	13.9 in. (353.3 mm)	13.9 in. (353.3 mm)
Weight	172 lb (78 kg)	172 lb (78 kg)
Air Requirements:		
Combustion	19 ft ³ /min (0.54 m ³ /min)	19 ft ³ /min (0.54 m ³ /min)
Engine/Generator Cooling	300 ft ³ /min (8.5 m ³ /min)	300 ft ³ /min (8.5 m ³ /min)
Fuel Pump Lift	3 ft (0.91m)	—

* 100 VAC 60 Hz model only

50 HERTZ MODELS	3600 KY	3300 KY (LP)
GENERATOR		
Generator Type	Onan, Revolving Field, 2-Pole	Onan, Revolving Field, 2-Pole
Frequency (Hertz)	50	50
Power (Watts)	3600	3300
Voltage	220	220
Current (Amperes)	16.4	15
ENGINE		
Engine Model	Onan EO95H-G	Onan EO95H-G
Engine Type	4-Stroke, Single Cylinder, OHV	4-Stroke, Single Cylinder, OHV
Engine Speed	3000 rpm	3000 rpm
Ignition Type	Electronic Magneto (Breakerless)	Electronic Magneto (Breakerless)
Fuel	Gasoline	LPG - Vapor (11 inches W.C.)
Engine Oil Capacity	1.6 qt (1.5 L)	1.6 qt (1.5 L)
Battery Requirements:		
Battery Voltage	12-Volt	12-Volt
Cold Cranking Amps	360 (450 Below 32°F [0°C])	360 (450 Below 32°F [0°C])
Spark Plug Gap	0.025 in. (0.64 mm)	0.025 in. (0.64 mm)
Average Fuel Consumption:		
No Load	0.13 gph (0.5 L/h)	1.32 lbs/h (0.6 kg/h)
Half Load	0.32 gph (1.2 L/h)	2.42 lbs/h (1.1 kg/h)
Full Load	0.53 gph (2 L/h)	3.09 lbs/h (1.4 kg/h)
DIMENSIONS		
Length	30 in. (762 mm)	30 in. (762 mm)
Width	19.68 in. (499.9 mm)	19.68 in. (499.9 mm)
Height	13.9 in. (353.3 mm)	13.9 in. (353.3 mm)
Weight	172 lb (78 kg)	172 lb (78 kg)

Maintenance Record

Keep a record of all periodic and unscheduled maintenance. Record the service date and the number of operating hours from the optional hour meter (if equipped).

Refer to the Maintenance Schedule on page 13 for the time interval between maintenance procedures. Record the name and address of your Onan service center and keep all of your service receipts.

DATE	HOUR METER READING	SERVICE PERFORMED / NOTES

Record the name, address, and phone number of your authorized Onan service center.

Notes

Onan

Cummins Power Generation
1400 73rd Avenue N.E.
Minneapolis, MN 55432
763-574-5000
Fax: 763-574-8087



**Power
Generation**

Cummins and Onan are registered trademarks of Cummins Inc.

Redistribution or publication of this document
by any means, is strictly prohibited.