



Specification sheet

Fire Pump Drive Engine

CFPI59-F30



Description

Engine Series - Cummins B5.9 Series

Exhaust Emissions - Non-certified

When performance matters, we take notice. Our engines are an assurance of safety specifically designed to fit your needs. The CFPI59 engine is built to last. With over 12,000 installations of Cummins B5.9 engine worldwide, the painstaking attention to detail in the design makes this engine reliable and durable. It'll be on the job, ready to start every day for years to come.

Features

Certified Power - The CFPI59-F30 complies with NFPA 20 and is UL 1247- listed and FM 1333-approved.

Control System - The industry-leading, state-of-the-art Fire Pump Control Panel (FPCP) provides total fire pump drive engine system integration and intuitive operation, including:

- Analog display of engine parameters;
- Microcontroller override system for critical signal redundancy;
- Critical operation mode with Local/ Remote operating features.
- Adjustable gauge setting system.
- Hard key starting arrangements.

Warranty and Service - Our models are backed by a comprehensive warranty and worldwide distributor network.

Model	Operating Speed (rpm)	Rating	1	2	3	4	5	6	7
CFPI59-F30	2100	HP	151	140	135	120	105	100	90
		kW	113	104	101	90	78	75	67

General Engine Data

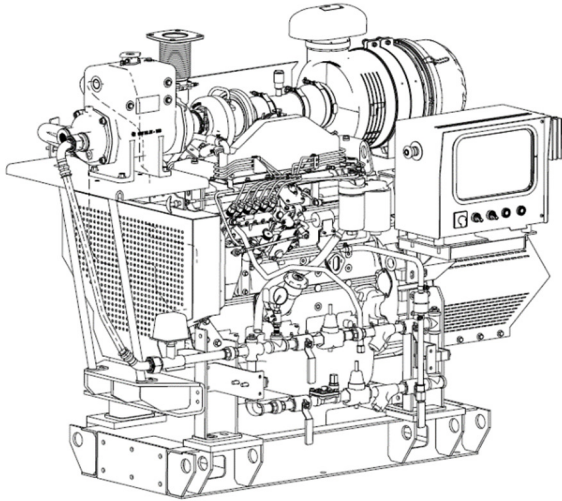

Engine Family	Industrial
Engine Type	4 Cycle; In-Line, 6 Cylinder
Aspiration	Turbocharged, aftercooled
Bore and Stroke	4.02 x 4.72 in. (102 x 120 mm)
Displacement	359 in ³ (5.9 L)
Rotation	Counterclockwise from flywheel end
Compression Ratio	17.5:1
Valves per Cylinder	Intake - 1 Exhaust - 1
Fuel System	Bosch Mechanical
Maximum Allowable Bending Moment @ Rear Face of Block	1000 lb.-ft. (1356 N-m)
Approx. estimated Wet Weight*	~1587 lbs. (720 kg)

*Weight includes engine, cooling loop, heat exchanger, fire pump control Panel, standard air cleaner, std exhaust flex, and all fluids.

Equipment	Standard	Optional
Air Cleaner	Normal-duty, two-stage with replaceable elements (disposable, treated for high humidity indoor service)	N/A
Alternator	12V-DC, 55 amps; includes belt guard	N/A
Cooling Loop	3/4" diameter for fresh water; includes solenoid, alarm sensors and FM-approval	N/A
Cooling System	Tube and shell type, 60 PSI with NPTF connections	N/A
Engine coolant Heater	240V-AC, 2000 watts	N/A
Exhaust Protection	Metal guards on exhaust system	N/A
Exhaust Flex Connection	Stainless steel flex, Flange type	N/A
Flywheel Power Take-Off	Flywheel	Driveshaft (UL-Certified / Non-certified) Coupling (Non-certified)
Fuel Connections	Fire-resistant flexible supply and return lines	N/A
Fuel Filter	Primary filter & water separator with priming pump	N/A
Governor, Speed	Constant speed, adjustable	N/A
Fire Pump Control panel	Analog engine parameter display with micro controller for engine RPM display and over speed feature.	N/A
Lube Oil Cooler	Engine-water-cooled, plate type	N/A
Lube Oil Filter	Full-flow	N/A
Lube Oil Pump	Gear-driven	N/A
Manual Start Controls	On fire pump control panel and/or contactors	N/A
Overspeed Controls	Electronic with reset and test on fire pump control panel	N/A
Starter	12V-DC	N/A
Battery	12V-DC, 100AH, VRLA (In customer scope)	N/A
Base rail	Short – Modular for engine	Long – Customized for pump Mounting
Silencer (Muffler)	Industrial with spark arrestor	Residential

Air Induction System

Maximum Temperature Rise Between Ambient Air and Engine Air Inlet	45 °F (25 °C)
Maximum Inlet Restriction with Clean Filter	15 in. H ₂ O (381 mm H ₂ O)
Maximum Inlet Restriction with Dirty Filter	25 in. H ₂ O (635 mm H ₂ O)
Recommended Air Cleaner Element - (Standard)	Cummins Filtration A064F305; (Primary- A042M073, Secondary- A042M072)

Lubrication System

Oil Pressure Range at Rated	30-60 PSI (207-414 kPa)
Oil Capacity of Pan (High - Low)	15-13 qt. (14.2-12.3 L)
Total System Capacity	4.3 gal. (16.3 L)
Recommended Lube Oil Filter	Cummins Filtration LF 9319; (PN- 3937743)

Cooling System*

Raw Water Working Pressure Range at Heat Exchanger	60 PSI (413 kPa) MAX
Recommended Minimum Water Supply Pipe Size to Heat Exchanger	0.75 in. (19.05 mm)
Recommended Minimum Water Discharge Pipe Size From Heat Exchanger	1.00 in. (25.40 mm)
Coolant Water Capacity (Engine Only)	2.4 gal. (9.1 L)
Approx total coolant capacity(Including HE)	5.8 gal. (22.1 L)
Standard Thermostat - Type	Modulating
Standard Thermostat - Range	180-203 °F (82-95 °C)
Maximum coolant fill rate	11 lpm
Minimum Raw Water Flow:	
- with Water Temperatures to 60 °F (16 °C)	17.7 GPM (1.12 L/sec)
- with Water Temperatures to 80 °F (27 °C)	18.5 GPM (1.17 L/sec)
- with Water Temperatures to 100 °F (38 °C)	19.5 GPM (1.23 L/sec)

* A jacket water heater is mandatory on this engine. The recommended heater wattage is 2000 down to 40 °F (4 °C)

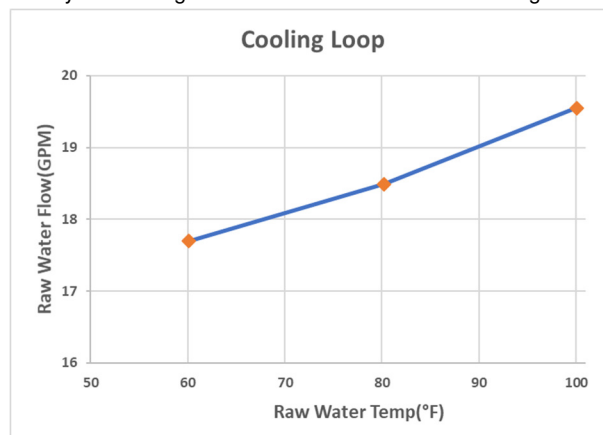

Exhaust System

Maximum Allowable Back Pressure by Complete Exhaust System	40.8 in. H ₂ O (10.2 kPa)
Exhaust Pipe Size Normally Acceptable	4 in. (102 mm)

Noise Emissions -

Top	99.0 dBa
Right Side	96.3 dBa
Left Side	98.9 dBa
Front	96.3 dBa
Exhaust	116 dBa

The noise emission values are approximate estimated sound pressure levels at 3.3 ft. (1 m).

Fuel Supply/Drain System

Model	Operating Speed(rpm)	Rating	1	2	3	4	5	6	7
CFPI59-F30	2100	HP	151	140	135	120	105	100	90
		kW	113	104	101	90	78	75	67
	Fuel Rate	(Gal/hr)	8.5	7.7	7.2	6.7	5.8	5.4	4.9
	Fuel Rate	(L/hr)	32.1	29.0	27.1	25.2	21.8	20.5	18.6

Fuel Type (ASTM D 975)	No. 2 diesel only
Minimum Supply Line Size	0.375 in. (9.5 mm)
Minimum Drain Line Size	0.375 in. (9.5 mm)
Maximum Fuel Height above C/L Fuel Pump with check valve (A066K091 / A067M023)- in. (m)	50 in. (1.27 m)
Maximum Fuel Height above C/L Fuel Pump with check valve (178079 / A071X672)- in. (m)	6 in. (0.15m)
Recommended Fuel Filter – Primary	Cummins Filtration FF91241 (3931063)
Recommended Fuel Filter – Secondary	None
Recommended Fuel water separator	Cummins Filtration FF91241 (4093730)
Maximum Restriction @ Lift Pump-Inlet - With Clean Filter	4.0 in. Hg (102 mm Hg)
Maximum Restriction @ Lift Pump-Inlet - With Dirty Filter	8.0 in. Hg (203 mm Hg)
Maximum Return Line Restriction - Without Check Valves	20 in. Hg (508 mm Hg)
Minimum Fuel Tank Vent Capability	12 ft ³ /hr (0.36 m ³ /hr)
Maximum Fuel Temperature @ Lift Pump Inlet	160 °F (71 °C)

Starting and Electrical System

Min. Recommended Battery Capacity - Cold Soak at 0 °F (-18 °C) or Above (with starting aid)	12V
Engine Only - Cold Cranking Amperes	950 CCA*
Engine Only - Reserve Capacity	430 minutes*

*Based on FM requirement for a minimum of 900 CCA and 430 Reserve Capacity Minutes

Battery Cable Size - Minimum of 2/0 AWG and Maximum Cable Length Not to Exceed 6 ft. (1.5 m)	12V
Maximum Resistance of Starting Circuit	0.002 Ohms
Typical Cranking Speed	120 RPM
Alternator (Standard), Internally Regulated	55 amps

Wiring for Automatic Starting (Negative Ground)..... Standard
Reference Wiring Diagram.....A065J396

Performance Data

Model	Operating Speed(rpm)	Rating	1	2	3	4	5	6	7
CFPI59-F30	2100	HP	151	140	135	120	105	100	90
		kW	113	104	101	90	78	75	67
	Ventilation Air Required	CFM (liter/sec)	342 (161)	315 (149)	309 (146)	286 (135)	265 (125)	247 (117)	244 (115)
	Exhaust Gas Flow	CFM (liter/sec)	884 (417)	778 (367)	751 (354)	674 (318)	601 (284)	553 (261)	530 (250)
	Exhaust Gas Temperature	°F (°C)	905 (485)	855 (457)	833 (445)	801 (427)	743 (395)	723 (384)	689 (365)
	Heat Rejection to Coolant	BTU/min. (kW)	4583 (80)	4140 (73)	4046 (71)	3575 (63)	3199 (56)	3152 (55)	2917 (51)
	Heat Rejection to Ambient	BTU/min. (kW)	828 (15)	683 (12)	623 (11)	445 (8)	412 (7)	414 (7)	331 (6)

Engine Performance Curve for CFPI59-F30

Torque Output

Model CFPI59-F30	RPM	lb-ft	N-m
F30-1	2100	378	512
F30-2	2100	350	475
F30-3	2100	338	458
F30-4	2100	300	407
F30-5	2100	263	356
F30-6	2100	250	339
F30-7	2100	225	305

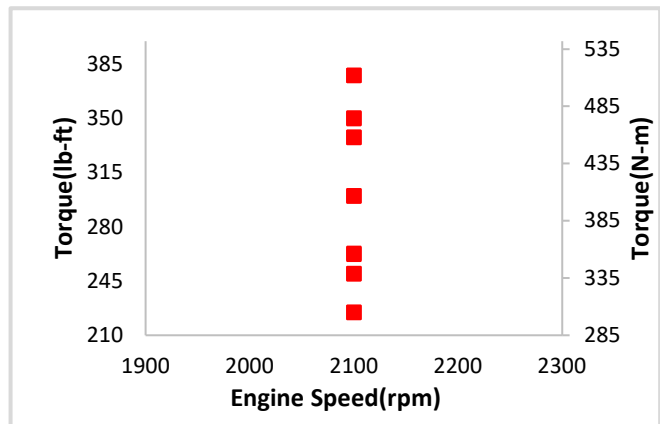

Horsepower Output

Model CFPI59-F30	RPM	HP	kW
F30-1	2100	151	113
F30-2	2100	140	104
F30-3	2100	135	101
F30-4	2100	120	90
F30-5	2100	105	78
F30-6	2100	100	75
F30-7	2100	90	67

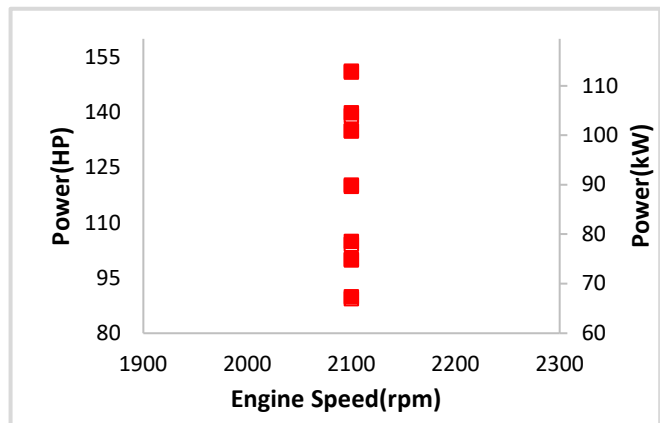

Operating Conditions

All data is based on the engine operating with fuel system, water pump, lubricating oil pump, air cleaner, and alternator; not included are compressor, fan, optional equipment, and driven components. Data is based on operation at SAE standard J1349 conditions of 300 ft. (91.4 m) altitude, 29.61 in. (752 mm) Hg dry barometer, and 77 °F (25 °C) intake air temperature, using No.2 diesel or a fuel corresponding to ASTM-D2.

Altitude Above Which Output Should be Limited - ft. (m)300(91.4)
 Correction Factor per 1000 ft. (305 m) above Altitude Limit3%
 Temperature Above Which Output Should be Limited - °F (°C).....77(25)
 Correction Factor per 10 °F (11 °C) Above Temperature Limit.....1%(2%)

Fire Pump Control Panel (FPCP)



The Cummins FPCP is an integrated microcontroller-based control system that provides full Analog + digital technology with enhanced accuracy and built-in redundancy.

Reliable design –

Designed and tested with isolated mounting to minimize vibration for longer life and durability, the Cummins FPCP proves reliable in harsh environments.

Advanced control methodology –

The Cummins FPCP allows for local and remote operation along with remote indication capabilities.

Certified Quality –

The Cummins FPCP is UL 1247-listed and FM 1333-approved.
Certified & tested according to UL 50 & 50E standards

Operator Panel Features

Operator/Display Panel

- Gauges for engine temperature, pressure and battery voltage indication.
- Local/remote, start/stop, and overspeed reset.
- Tachometer for engine rpm, engine running hours, engine running status and over speed function.
- Assembly enclosure that meets Type 2 and Type 4X design requirements and is water, corrosion, fire, and impact - resistant.

Functional

- Configurable display units for temperature in degrees Fahrenheit or Celsius and pressure in PSI or kPa.
- Ability to crank the fire pump drive engine from Battery A, Battery B, or both.
- Fixed engine overspeed adjustments in +/- 10 RPM increments.
- Overspeed shutdown.

Environmental

- Operating temperature - 4 to 158 °F (minus 20 to 70 °C).
- Storage temperature - minus 22 to 176 °F (minus 30 to 80 °C).
- EMI EMC certified.

Electrical

- 8-30 VDC operating voltage(only control panel)
- Reverse polarity protected.
- Screw slot terminal block interface.
- Built-in micro controllers and bypass scheme for increased reliability.

Mechanical

- Gland hole at bottom for easy field installation.
- Simplified internal design for efficiency and ease of customer connections.
- CRCA plate with 2 mm thickness with anodized tally plates.
- Fast Drying SPL ENL FIRE RED (IS 536) powder coat finish.

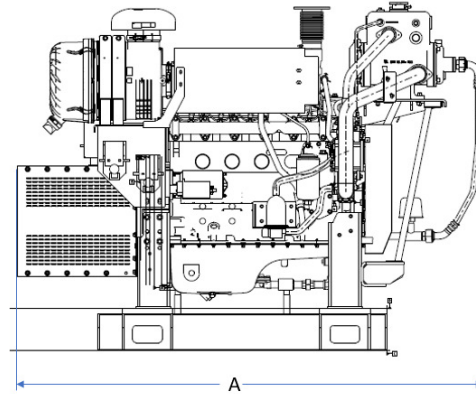
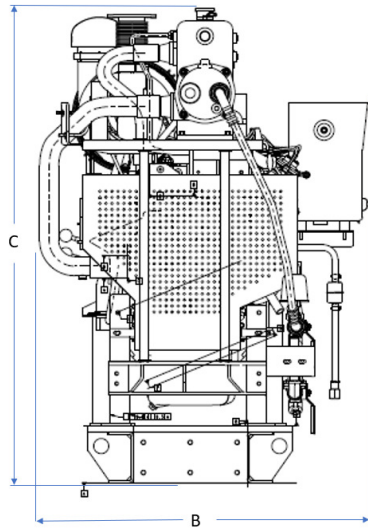

This outline drawing is for reference only.
Do not use for installation design.

	Dim "A" in. (mm)	Dim "B" in. (mm)	Dim "C" in. (mm)
CFPI59-F30	74.1 (1883)	38.6 (980)	55.6 (1413)

NOTE: Consult drawings or contact the factory for additional information.

ISO 9001 : 2015
IATF - 16949

This product has been manufactured under the controls established by an IATF Certification management system that conforms with ISO 9001:2015

NOTE: Codes or standards compliance may not be available with all model configurations - consult factory for availability. Specifications are subject to change without notice



Cummins India Limited,
 Cummins India Office Campus,
 Tower- A, 8th Floor, Survey No-21
 Balewadi, Pune, MH-411045, India

www.cummins.com