



Installation, operation, and maintenance manual

**Fire pump drive engine
CFP15E series**

This manual contains proprietary information to equipment produced by Cummins and is being supplied solely for the purpose of installing, operating, maintaining and servicing the fire pump drive engine purchased from Cummins in De Pere, Wisconsin.

Please visit us at <https://www.cummins.com/engines/fire-pump-drives/maintenance-current-models> to view the English version of this manual in color, as well as experience a wealth of information about Cummins fire pump drive engines.



This product has been manufactured under the controls established by a Bureau Veritas Certification approved management system that conforms with ISO 9001:2015.



Fire pump drive engine

Limited warranty

Description

This limited warranty applies to all Cummins fire pump drive engines (hereinafter referred to as "Cummins" branded fire pump drive engines and associated accessories (hereinafter referred to as "Product")). This warranty covers any failures of the Product, under normal use and service, which result from a defect in material or factory workmanship.

Warranty period:

The warranty start date for stationary Product is the date of initial start-up, demonstration or eighteen (18) months after factory ship date, whichever is sooner.

Base engine warranty duration (whichever occurs first): 2 years/2000 hours.

Cummins responsibilities:

In the event of a failure of the Product during the warranty period due to defects in material or workmanship, Cummins will only be responsible for the following costs:

- All parts and labor required to repair the Product.
- Reasonable travel expenses to and from the Product site location.
- Maintenance items that are contaminated or damaged by a warrantable failure.

Owner responsibilities:

The owner will be responsible for the following:

- Notifying a Cummins distributor or dealer within thirty (30) days of the discovery of failure.
- Installing, operating, commissioning and maintaining the Product in accordance with Cummins published policies and guidelines.
- Providing evidence for date of commissioning.
- Providing sufficient access to and reasonable ability to remove the Product from the installation in the event of a warrantable failure.
- Incremental costs and expenses associated with Product removal and reinstallation resulting from difficult or non-standard installations.
- Costs associated with Fire Watch Protection during Product being repaired.
- Costs associated with labor overtime and premium shipping requested by the owner.
- All downtime expenses, fines, all applicable taxes, and other losses resulting from a warrantable failure.

Limitations:

This limited warranty does not cover Product failures resulting from:

- Inappropriate use relative to designated power rating or application guidelines.
- Normal wear and tear, negligence, accidents or misuse.
- Improper and/or unauthorized installation.
- Lack of maintenance or unauthorized repair.
- Noncompliance with any Cummins published guideline or policy.
- Use of improper or contaminated fuels, coolants or lubricants.
- Improper storage before and after commissioning.
- Owner's delay in making Product available after notification of potential Product problem.
- Replacement parts and accessories not authorized by Cummins.
- Owner or operator abuse or neglect such as: operation without adequate coolant or lubricants; over-fueling; over-speeding; lack of maintenance to lubricating, cooling or air intake systems; late servicing and maintenance; improper storage, starting, warm-up, run-in or shutdown practices, or for progressive damage resulting from a defective warning device.
- Damage to parts, fixtures, housings, attachments and accessory items that are not part of the fire pump package.

This limited warranty does not apply to:

- Costs of maintenance, adjustments, installation, commissioning or start-up.
- Starting batteries and enclosures.
- Components added to the Product after shipment from Cummins.
- Block heaters are warranted for one (1) year from date in service

Please contact your local Cummins Sales and Service for clarification concerning these limitations.

Extended warranty

Cummins Inc. offers several levels of Extended Warranty Coverage (**Base Engine Only**). Please contact your local Cummins Distributor for details.

Cummins right to failed components:

Failed components claimed under warranty remain the property of Cummins. Cummins has the right to reclaim any failed component that has been replaced under warranty.

THE WARRANTIES SET FORTH HEREIN ARE THE SOLE WARRANTIES MADE BY CUMMINS INC. IN REGARD TO THE PRODUCT. CUMMINS INC. MAKES NO OTHER WARRANTIES, EXPRESS OR IMPLIED, OR OF MERCHANTABILITY OR FITNESS FOR A PARTICULAR PURPOSE. IN NO EVENT IS CUMMINS INC. LIABLE FOR INCIDENTAL OR CONSEQUENTIAL DAMAGES.

This limited warranty shall be enforced to the maximum extent permitted by applicable law. This limited warranty gives the owner specific rights that may vary from state to state or from jurisdiction to jurisdiction.

See the Cummins Inc. warranty bulletins for additional base engine warranty details: [US & Canada: 3381321](#)
[International: 3381322](#).



Cummins fire pump drive engines have been manufactured under the controls established by a Bureau Veritas Certification approved management system that conforms with ISO 9001:2015.



Cummins Sales and Service
875 Lawrence Drive
DePere, Wisconsin 54115

www.cummins.com

Doc. A042G861 Rev. 2

This page is intentionally left blank.

Table of Contents

1 - Safety

1.1 Introduction	1
1.2 Use of advisory and cautionary statements	1
1.2.1 Advisory statements	1
1.2.2 Cautionary statements	1
1.3 General safety precautions	2

2 - Description

2.1 Introduction	3
2.2 Fire pump drive engine nameplate	4
2.3 Fire pump controller	4
2.4 CFP15E components	5
2.5 Fire Pump Digital Panel (FPDP)	7
2.5.1 Engine STOP button	7
2.5.2 Customer access port	8
2.5.3 Diagnostics connector	8
2.5.4 Engine ECM power supply	8
2.5.5 Tachometer	8
2.5.6 Battery "A" and "B" voltmeters	8
2.5.7 SCREEN soft key	8
2.5.8 RESET/STOP switch	8
2.5.9 IDLE soft key	8
2.5.10 Crank battery A and B momentary start switches	9
2.5.11 ECM A/ECM B selector switch and indicator lamps	9
2.5.12 Automatic or Manual mode of operation selector switch and indicator lamps	9
2.5.13 MENU soft key	9
2.5.14 Hour meter	9
2.5.15 Engine oil pressure gauge	9
2.5.16 Coolant temperature gauge	10
2.6 FPDP informational displays	10
2.6.1 Fault code warning displays	10
2.6.1.1 Yellow warning indicators	10
2.6.1.2 Red warning indicators	12
2.6.2 Overspeed warning indicator	13
2.6.3 VSPLC information and warnings	13
2.6.4 DPEM fault screens	15
2.7 Electronic control module (ECM)	16
2.8 Digital panel expansion module (DPEM) (optional)	17
2.9 Fuel supply and drain	17
2.10 High pressure injection (HPI) fuel system	17
2.11 Fuel cooling system	17
2.12 Air intake system	18
2.13 Cooling water system	19
2.14 Engine oil system	21
2.15 Engine exhaust system	21

3 - Installation

3.1 Introduction 23

3.2 Receiving and handling 23

3.3 Site preparation 23

3.4 Drive shaft installation 23

3.5 Fuel supply installation 25

3.6 Cooling water supply installation 26

3.7 Battery installation 27

3.8 Signal and control installation 29

 3.8.1 FPDP interface terminal strip 29

 3.8.2 Battery charger interface 31

3.9 Coolant system preparation 32

3.10 Charge air cooler (CAC) inspection 33

3.11 Lubricating oil system preparation 33

3.12 Variable Speed Pressure Limiting Control (VSPLC) preparation 34

3.13 Pre-start inspections 35

3.14 Engine monitoring 35

3.15 Start-up validation 36

 3.15.1 High Water Temp 38

 3.15.2 Low Water Temp 39

 3.15.3 Low Oil Pres 39

 3.15.4 Fuel Inj. Malf. 40

 3.15.5 Hi Raw Water Temp 40

 3.15.6 Raw Water Strain 41

 3.15.7 TB-303/304 - ECM Warning/ECM Failure 42

 3.15.8 TB-305-307 - Custom Outputs - simulation from the Terminal Block Test screen 44

 3.15.9 TB-301 - ECM Switch 44

 3.15.10 TB-3 - Overspeed Switch 44

 3.15.11 TB-2 - Crank Termination Switch 46

 3.15.12 Troubleshooting a Terminal Block Connection: 47

4 - Operation

4.1 Introduction 49

4.2 Starting and stopping procedures 49

 4.2.1 Local starting/stopping procedure 49

 4.2.2 Emergency starting procedure 50

4.3 Fire Pump Digital Panel (FPDP) screens and adjustments in automatic mode 53

 4.3.1 The SCREEN soft key 54

 4.3.2 The MENU soft key - Settings Menu 55

 4.3.2.1 ENGINE SETUP screen 55

 4.3.2.2 OVERSPEED TEST screen 59

 4.3.2.3 IMPERIAL/SI VALUES screen 59

 4.3.2.4 ANALOG VALUES screen 60

 4.3.2.5 AUTOSWITCH screen 60

 4.3.2.6 FAULT CODES screen 62

 4.3.2.7 RPM ADJUSTMENT screen 63

 4.3.2.8 DPEM (optional) 64

4.4 FPDP screens and adjustments in manual mode - IDLE soft key 64

4.5 Engine/turbocharger cool down 65

 4.5.1 Automatic shutdown - cool down timer 66

 4.5.2 Automatic shutdown - engine protection 66

 4.5.3 Manual shutdown - from the fire pump controller 66

 4.5.4 Manual shutdown - from the FPDP 66

Table of Contents

5 - Maintenance

5.1	Introduction	67
5.2	Engine operation reports	67
5.3	Weekly maintenance	70
5.3.1	General	70
5.3.2	Air cleaner filter and piping	70
5.3.3	Cooling system	71
5.3.4	Engine oil system	72
5.3.5	Fuel system	73
5.3.6	Engine exhaust system	73
5.3.7	Electrical supply and controls	73
5.3.8	Crankcase ventilation hose	73
5.3.9	Heat exchanger - cooling water strainers	74
5.3.10	Batteries	74
5.3.11	Engine test run	75
5.3.12	Engine operation checks	76
5.3.12.1	Crank termination setpoint	76
5.3.12.2	Engine speed adjustment	76
5.3.13	Engine coolant heater	76
5.4	Annual maintenance	77
5.4.1	Electrical components	77
5.4.2	Turbocharger mounting nuts	78
5.4.3	Engine supports	78
5.4.4	Fuel pumps and filters	79
5.4.5	Engine oil and filter	80
5.4.6	Drive shaft	82
5.4.7	Coolant pump/alternator belt	83
5.4.8	Raw water zinc anode	84
5.4.9	Heat exchanger pressure test	84
5.4.10	Turbocharger	85
5.5	Every two years	85
5.5.1	Coolant pump	85
5.5.2	Cooling system - heat exchanger	86
5.6	Every four years	88
5.6.1	Coolant thermostat removal/installation	89
5.6.2	Coolant pump/alternator belt replacement	90

6 - Troubleshooting

6.1	Introduction	91
6.2	Engine Will Not Start	92
6.3	Engine Cranks But Will Not Start	93
6.4	Engine Starts But Continues to Crank	95
6.5	Engine Will Not Stop	96
6.6	Low Battery Voltage	97
6.7	Fault Code Charts - CFP15E/EVS, CFP23E/EVS, CFP30E, and CFP60E	98

7 - Component parts and assemblies

7.1	Repairs and technical service	107
7.2	Recommended spare parts inventory	107
7.3	Ordering parts	107
7.4	Engine data and torque values	107

7.5 Cap screw markings and torque values 114

 7.5.1 Cap screw identification 114

 7.5.1.1 Metric cap screw identification and head markings 114

 7.5.1.2 US customary cap screw identification and head markings 114

 7.5.2 Cap screw torque values 115

7.6 CFP15E assembly drawings 116

1 - Safety

1.1 Introduction

Cummins manuals should be considered part of the equipment. Keep the manuals with the equipment. If the equipment is traded or sold, give the manuals to the new owner.

The fire pump drive engine has been carefully designed to provide safe and efficient service when properly installed, maintained, and operated. However, the overall safety and reliability of the complete system is dependent on many factors outside the control of the fire pump drive engine manufacturer. To avoid possible safety hazards, make all mechanical and electrical connections to the fire pump drive engine exactly as specified in this manual.

All systems external to the fire pump drive engine (fuel, electrical, etc.) must comply with all applicable codes. Make certain all required inspections and tests have been completed and all code requirements have been satisfied before certifying the installation is complete and ready for service. All personnel responsible for operation and maintenance of the equipment should read and thoroughly understand this manual.

SAVE THESE INSTRUCTIONS.

Safe and efficient operation can be achieved only if the equipment is properly operated and maintained. Many accidents are caused by failure to follow fundamental rules and precautions.

1.2 Use of advisory and cautionary statements

1.2.1 Advisory statements

Advisory statements are used throughout this manual to call attention to special information and correct operating procedures. Throughout this manual, these Advisory Statements are delineated by the terms "NOTE" and "IMPORTANT" in uppercase letters:

NOTE: *A general advisory statement relating to equipment operation and maintenance procedures.*

IMPORTANT: *A specific advisory statement intended to prevent damage to the equipment or its associated components.*

1.2.2 Cautionary statements

Cautionary statements highlight particular safety precautions pertaining to personal injury and/or damage to the equipment. Cautionary Statements are always preceded by the following symbols:

This symbol warns of immediate hazards which will result in severe personal injury or death.

This symbol refers to a hazard or unsafe practice which CAN result in severe personal injury or death.

Indicates the presence of a hazard or unsafe practice which can result in equipment damage OR minor or major personal injury.

1.3 General safety precautions

Read and understand all of the safety precautions and warnings before performing any repair. Special safety precautions are included in the procedures when they apply. This list contains the general safety precautions that **must** be followed to provide personal safety:

Perform a walk around inspection and alert all area personnel that the equipment will be starting before manual operation.

Cummins engine manuals should be considered part of the equipment. Keep the manuals with the equipment. If the equipment is traded or sold, give the manuals to the new owner.

All personnel responsible for operation and maintenance of the equipment should read and thoroughly understand this manual.

- Do not operate faulty or damaged equipment. Ensure that all hoses, pipe connections, clamps and guards are in place and securely fastened. Electrical components should be kept in good working condition and repaired immediately by qualified personnel.
- After performing maintenance, remove all tools and foreign materials and reinstall and securely fasten ALL guards, covers, and protective devices.
- Exposed in-running belt nips can cause severe personal injury or dismemberment. Ensure that guards are in place and securely fastened before operation.
- Rotating drive shafts can lacerate, dismember, or cause strangulation. Keep hands, body parts, long hair, or loose-fitting clothing clear at all times.
- Never attempt to manually clean a machine while it is operating or in standby mode.
- Never open ports on tanks or piping while the engine is operating. Contact with pressurized agents can cause severe personal injury.
- Relieve all pressure in the air, oil, and the cooling systems before any lines, fittings, or related items are removed or disconnected.
- Engine fuel is flammable when in contact with electrical spark or flame sources. Remove all sources of spark or flame from the work area.
- Always use the same fastener part number (or equivalent) when replacing fasteners.
- Some state and federal agencies in the United States have determined that used engine oil can be carcinogenic and can cause reproductive toxicity. Dispose of waste oil in accordance with applicable requirements.

2 - Description

2.1 Introduction

This manual contains information for the correct operation and maintenance of a Cummins fire pump drive engine. Read and follow all safety instructions in [Section 1 - Safety](#). Keep this manual with the equipment. If the equipment is traded or sold, give the manual to the new owner.

Cummins fire pump drive engines have been designed in accordance with National Fire Protection Association (NFPA) 20 guidelines.

No deviations are permitted without prior written approval. These engines are to be used only for fire protection applications. [Figure 2-2](#) and [Figure 2-3](#) provide visual descriptions of the engine components for this fire pump drive engine.

Cummins reserves the right to make changes at any time. If any differences are found between an engine and the information in this manual, contact your local Authorized Repair Location.

The latest technology and the highest quality components were used to produce this engine. Cummins fire pump drive engines as packaged units (engine and accessories) have been approved by Factory Mutual (FM) Approvals and listed by Underwriters Laboratories (UL), Inc. and Underwriters Laboratories of Canada (ULC). When replacement parts are needed, we recommend using only genuine Cummins parts.



⚠ CAUTION

Injury may result and warranty is voided if fuel rate, revolutions per minute (RPM), or altitudes exceed published maximum values for this model and application.

2.2 Fire pump drive engine nameplate

Each fire pump drive engine is labeled with a nameplate that provides its unique information. A typical fire pump drive engine nameplate is shown in [Figure 2-1](#).

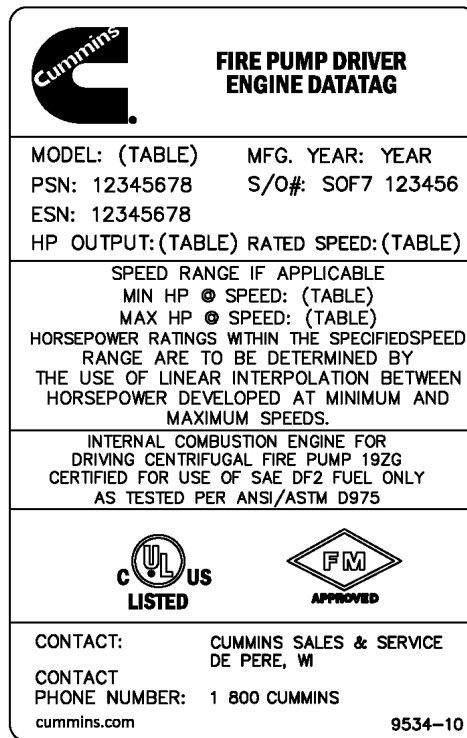

Figure 2-1 Fire pump drive engine nameplate (typical)

2.3 Fire pump controller

The fire pump controller starts the engine automatically when the Fire Pump Digital Panel (FPDP) is in automatic mode and a remote fire demand signal is received. The fire pump controller automatically shuts down the engine when the fire demand signal is discontinued. The fire pump controller is optionally supplied by Cummins or Cummins Sales and Service.

NOTE: With the fire pump controller in **manual** mode, starting and stopping the fire pump drive engine can be controlled by the FPDP, located on the fire pump drive engine itself.

CAUTION

Upon turning the fire pump controller to OFF, the fire pump drive engine may continue to run at a reduced speed to cool the engine down. To stop the fire pump drive engine at this point - in the case of an emergency - press the Engine STOP button on the FPDP rather than on the pump controller.

2.4 CFP15E components

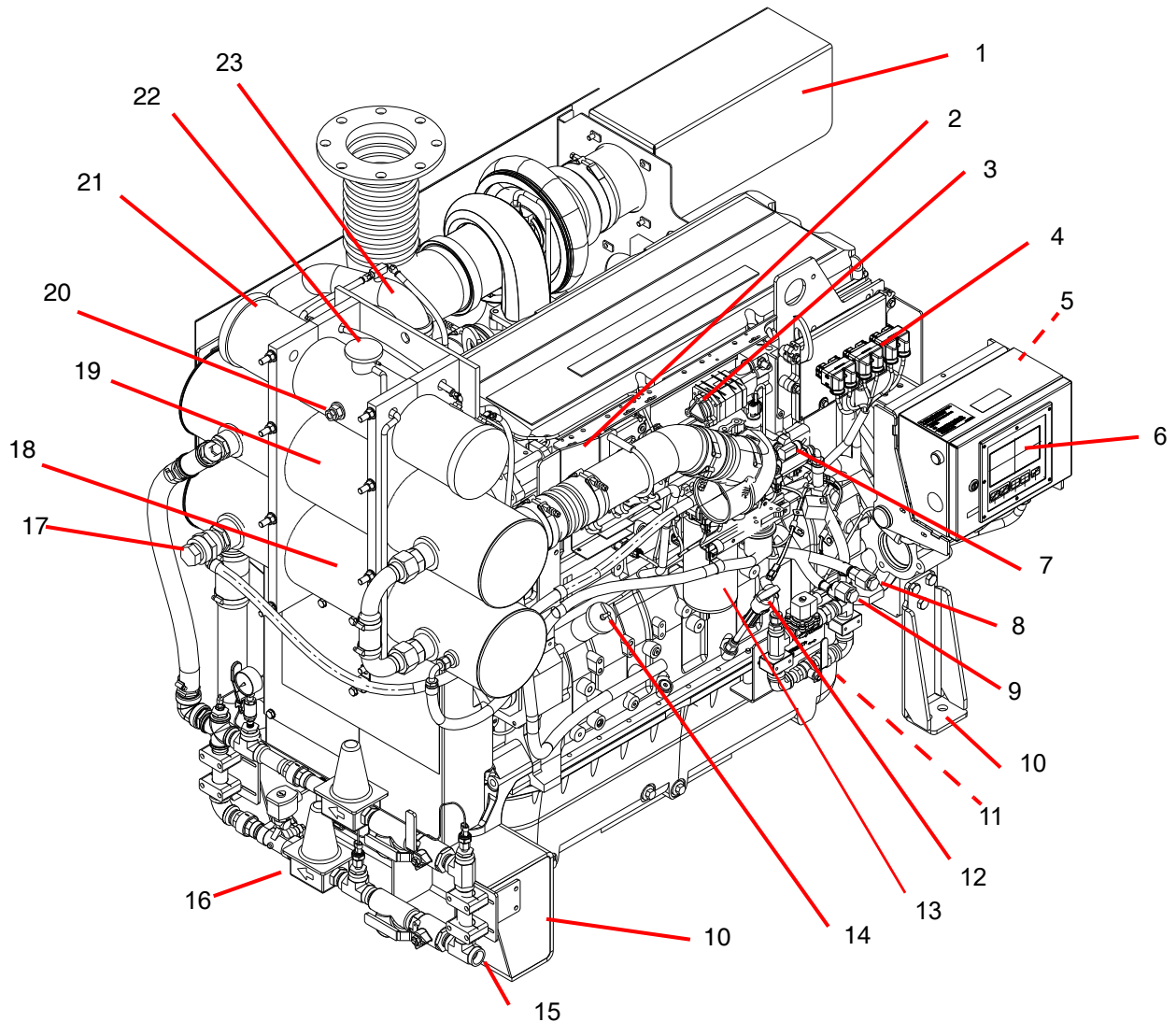

- | | |
|--|--|
| 1. Air cleaner assembly (intake) | 12. Engine oil dipstick |
| 2. Electronic control module (ECM) A | 13. Primary fuel filter |
| 3. Fuel pump | 14. Engine oil fill port |
| 4. Electronic control module (ECM) B | 15. Raw water inlet connection |
| 5. FPDP interface terminal strip - terminal blocks (TBs) | 16. Cooling loop |
| 6. FPDP | 17. Raw water discharge connection |
| 7. High pressure injection (HPI) fuel system | 18. Coolant/fuel cooling heat exchanger |
| 8. Fuel return line | 19. Charge air cooler (CAC) heat exchanger |
| 9. Fuel supply line | 20. Coolant level sight gauge |
| 10. Engine supports | 21. Coolant surge tank |
| 11. Oil pan drain port | 22. Coolant pressure/fill cap |
| | 23. Charge air cooler (CAC) hose |

Figure 2-2 Engine components - fire pump digital panel (FPDP) side

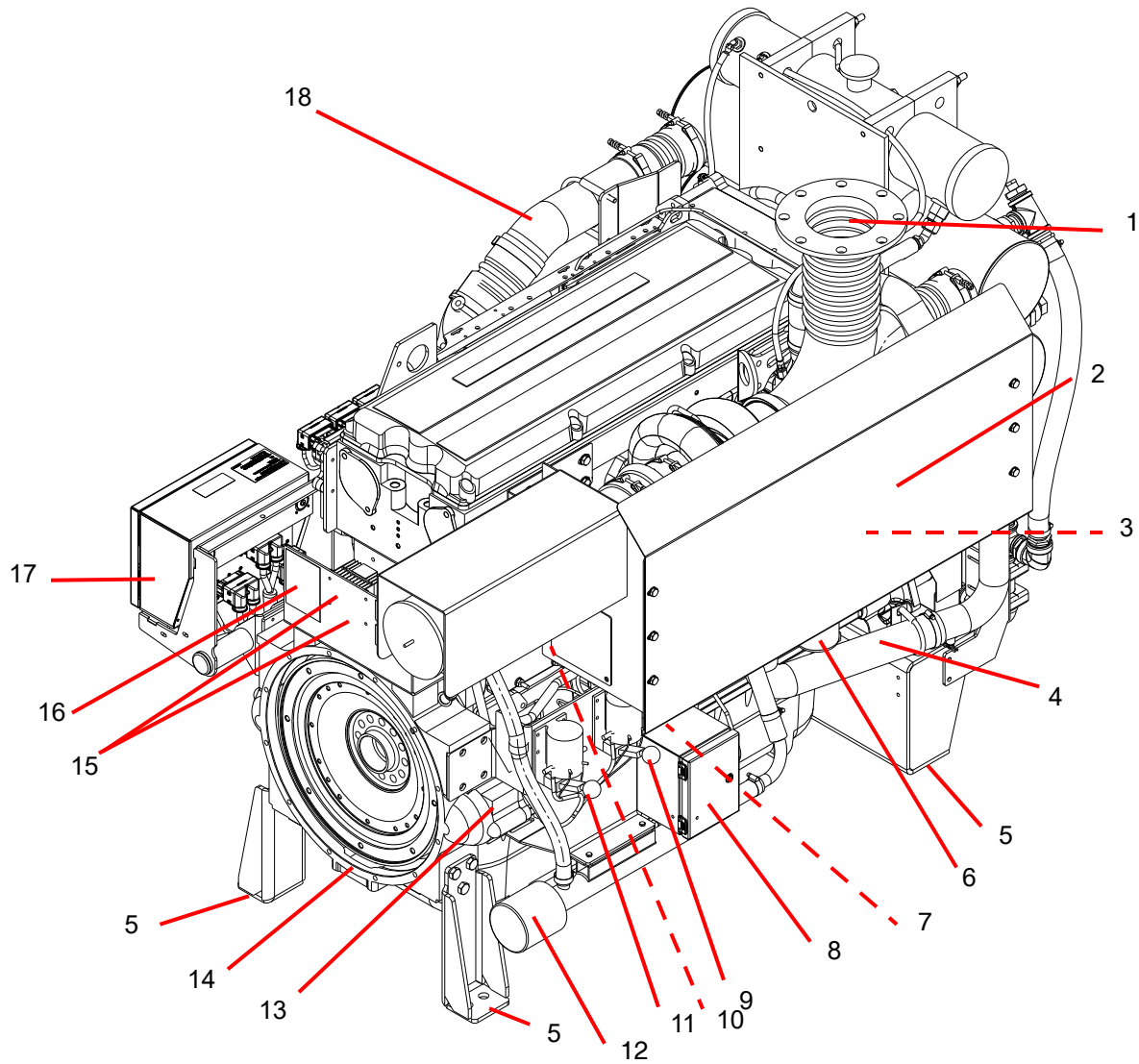

- | | |
|--------------------------------|------------------------------------|
| 1. Exhaust flex connection | 10. Air cleaner service indicator |
| 2. Manifold heat shield | 11. Battery starter contactor A |
| 3. Alternator | 12. Engine coolant heater |
| 4. Lower coolant hose/tube | 13. Starter motor |
| 5. Engine supports | 14. Flywheel housing |
| 6. Coolant filter | 15. Engine speed setting decals |
| 7. Engine oil filter | 16. Engine serial number decal |
| 8. Battery charger interface | 17. Manual start instruction decal |
| 9. Battery starter contactor B | 18. Upper coolant hose |

Figure 2-3 Engine components - turbocharger side

2.5 Fire Pump Digital Panel (FPDP)

The FPDP control panel (shown in [Figure 2-4](#)) is mounted on the left-hand side (or right-hand side - optional) of the flywheel end of the engine and contains controls for starting the engine, monitoring engine performance, and controlling fire pump drive engine operation.

In **manual** mode, the FPDP and the Electronic Control Module (ECM) remain active as long as battery power is available. In **automatic** mode, starting and stopping of the engine is controlled by the fire pump controller.

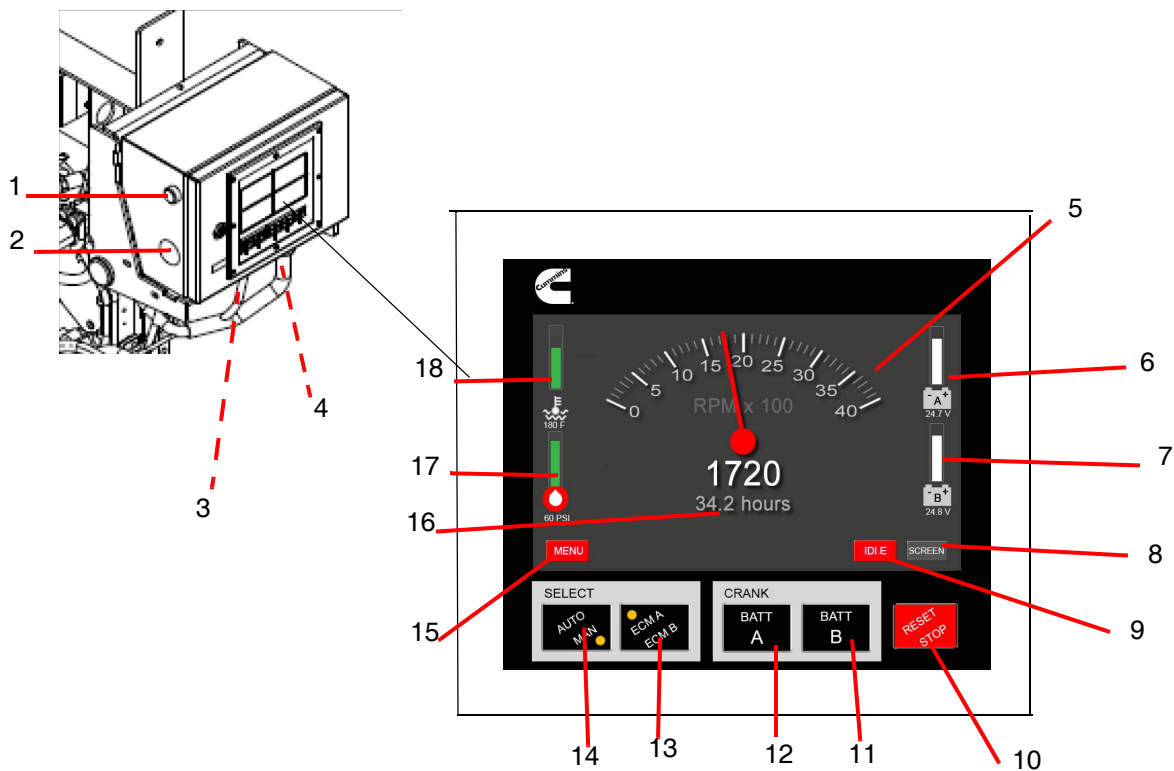

- | | |
|----------------------------|---|
| 1. Engine STOP button | 11. Crank battery B momentary start switch |
| 2. Customer access port | 12. Crank battery A momentary start switch |
| 3. Diagnostics connector | 13. ECM A/ECM B selector switch and indicator lamps |
| 4. Engine ECM power supply | 14. AUTO/MAN mode selector switch and indicator lamps |
| 5. Tachometer | 15. MENU soft key |
| 6. Battery "A" voltmeter | 16. Hour meter |
| 7. Battery "B" voltmeter | 17. Engine oil pressure gauge |
| 8. SCREEN soft key | 18. Coolant temperature gauge |
| 9. IDLE soft key | |
| 10. RESET/STOP switch | |

Figure 2-4 FPDP control panel

2.5.1 Engine STOP button

The Engine STOP Button (1) is located on the left side of the FPDP enclosure and is used to stop the operation of the engine in either manual or automatic mode. The button must be pressed and held until the engine has shut down.

NOTE: Upon release of the Engine STOP Button, the fire pump drive engine will attempt to restart, If there is still a “pump on demand” signal present from the fire pump controller. The engine must also be stopped at the fire pump controller.

2.5.2 Customer access port

The customer access knock-out (2) is located on the left side of the FPDP for ease of access. With an opening diameter of 1.38 in. (3.5 cm), this is the only knock-out provided for the pump controller interconnect.

IMPORTANT: If additional holes are placed in the FPDP, all warranty on the fire pump drive engine will be void.

2.5.3 Diagnostics connector

The Diagnostics Connector (3) is located on the bottom of the FPDP enclosure and is strictly used for Cummins service personnel.

2.5.4 Engine ECM power supply

The Engine ECM Power Supply plug-in (4) is located on the lower side of the FPDP to provide unswitched battery power to both ECM A and ECM B.

2.5.5 Tachometer

The Tachometer (5) displays the engine speed in revolutions per minute (RPM) whenever the engine is operating.

2.5.6 Battery “A” and “B” voltmeters

The Battery “A” (6) and Battery “B” (7) Voltmeters display the charge status - or Voltage Direct Current (VDC) - of the relative battery connections.

2.5.7 SCREEN soft key

The SCREEN soft key (8) allows the user to switch to a detailed pop up list of additional analog values (when available): exhaust temperature; cooling loop temperature; cooling loop differential pressure; and J1939 values including: oil temperature; intake manifold temperature; and intake manifold pressure.

2.5.8 RESET/STOP switch

The RESET/STOP Switch (9) serves multiple purposes:

- To shut off the engine by removing the ECM keyswitch/Fuel Shutoff (FSO) valve until the engine speed decelerates to 0 RPM.
- To reset the fire pump drive engine after an overspeed fault has been activated, allowing subsequent restarts of the fire pump drive engine.

2.5.9 IDLE soft key

The IDLE soft key (10) allows the user to run an electronic engine at a reduced speed while the FPDP is in manual mode (See [Operation: FPDP Screens and Adjustments in Manual Mode - IDLE Soft Key](#)). When the FPDP AUTO/MAN selector switch is in the MAN position (manual mode), the IDLE soft key will appear and display in red. When the engine idle command is active, the IDLE soft key will display in green.

NOTE: The IDLE soft key is only intended to be used for commissioning or service events.

2.5.10 Crank battery A and B momentary start switches

The CRANK BATT A (12) and CRANK BATT B (11) momentary start switches engage the starter when the FPDP is in MANUAL mode.

CRANK BATT A energizes battery contactor A and CRANK BATT B energizes battery contactor B. Both CRANK BATT A and CRANK BATT B buttons can be energized at the same time in the event both batteries are weak.

2.5.11 ECM A/ECM B selector switch and indicator lamps

The ECM A / ECM B selector switch and indicator lamps (13) illuminate in yellow, indicating which ECM is being used to control the engine.

If ECM A (normal position) is selected, ECM A is monitoring and controlling the engine.

If ECM B (alternate position) is selected, ECM B is monitoring and controlling the engine, and the FPDP will indicate that the engine is operating on the alternate ECM.

2.5.12 Automatic or Manual mode of operation selector switch and indicator lamps

The AUTO/MAN selector switch and indicator lamps (14) illuminate in yellow, indicating the operational state of the FPDP.

The MAN selector switch (for manual operation) is only to be selected for engine setup, testing, and emergency and maintenance procedures. When the FPDP is in manual mode, the ECM keyswitch/FSO and raw water solenoids are always activated, except under an overspeed condition.



Manual operation of the fire pump drive engine is intended for a short run time. Leaving the FPDP in manual mode for an extended period may cause fuel dilution.

The AUTO selector switch (for automatic operation) is the normal state of the FPDP, in which the fire pump controller starts and stops the engine. In automatic mode, the fire pump drive engine shuts down or enters engine cool down upon loss of a signal from the fire pump controller.

2.5.13 MENU soft key

The MENU soft key (15) on the FPDP display allows the user to open the menu options. A complete list of FPDP screens and their functionality is outlined in the [Operation Section](#) of this manual.

2.5.14 Hour meter

The Hour Meter (16) maintains a running total of the hours of engine operation (run time).

2.5.15 Engine oil pressure gauge

Based on user parameter screen display selection, the Engine Oil Pressure Gauge (17) displays the engine oil pressure in pounds per square inch (PSI) or kPa. The Engine Oil Pressure Gauge displays by default in three different colors:

- green - when the engine oil pressure is greater than 25 PSI (172 kPa);
- yellow - when the engine oil pressure is between 17 PSI (117 kPa) and 25 PSI (172 kPa); and
- red - when the engine oil pressure is below 16 PSI (110 kPa). *NOTE: Engine oil pressure displayed in red will also be accompanied by a low oil pressure fault. Refer to TB-4.*

2.5.16 Coolant temperature gauge

Based on user parameter screen display selection, the Coolant Temperature Gauge (18) displays the engine coolant temperature in degrees Fahrenheit or degrees Celsius. The Coolant Temperature Gauge displays in three different colors:

- green - when the coolant temperature is between 100-199 °F (38-93 °C);
- yellow - when the coolant temperature is between 200-211 °F (93-100 °C) OR below 100 °F (38 °C). *NOTE: when the coolant temperature is below 100 °F (38 °C), the yellow gauge will also be accompanied by a low coolant temperature fault. Refer to TB-312.; and*
- red - when the coolant temperature is greater than 212 °F (100 °C). *NOTE: the red gauge will also be accompanied by a high coolant temperature fault. Refer to TB-5.*

2.6 FPDP informational displays

2.6.1 Fault code warning displays

Fault codes diagnosed by the ECM are displayed in a yellow or red International Organization for Standardization (ISO) symbol and/or overlay box which lies atop the tachometer signal (the engine speed is still digitally displayed) to alert the operator to service the engine as soon as possible. Only the first seven active ECM faults will be displayed in the overlay.

NOTE: To remove the overlay box from atop the tachometer, press the SCREEN Soft Key.

2.6.1.1 Yellow warning indicators

The yellow ISO symbol (shown in [Figure 2-5](#)) or the yellow ISO symbol AND a large yellow box covering the tachometer (shown in [Figure 2-6](#)) indicate an engine malfunction that requires timely operator attention.

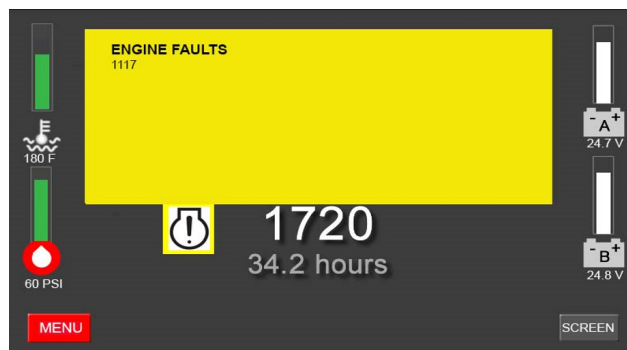

Figure 2-5 Yellow warning indicator ISO symbol only

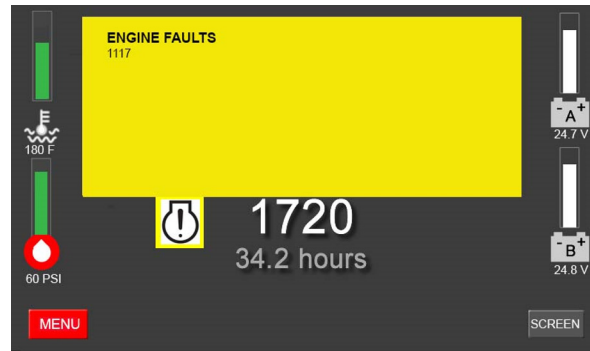

Figure 2-6 Yellow warning indicator ISO symbol and overlay box

When applicable, the FPDP may display the Yellow Warning Indicator for any one of the following operational issues:

- The ECM has sensed a **non-mission disabling fault**. A three- or four-digit diagnostic fault code will display on the FPDP which can then be used to help diagnose the engine malfunction. Refer to the Fault Code Chart in the [Fault Codes Section](#) or contact your local Cummins Distributor.
- **Communications have been lost with the ECM**. The FPDP communicates with electronically-controlled engines via J1939. As shown in [Figure 2-7](#), if communications are lost, "J1939 Lost" will appear on the top left of the screen. The warning lamp will also illuminate and the text "NWF" (which stands for "Network Failure") will replace all digital J1939 values, except the tachometer, which will revert to using a mechanical speed sensor for engine speed detection.

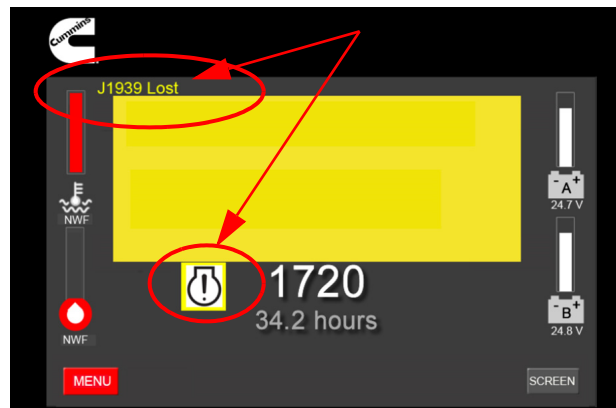

Figure 2-7 Loss of J1939 communications

- **Communications have been lost with the Digital Panel Expansion Module (DPEM).** As shown in [Figure 2-8](#), “DPEM Lost” will appear on the FPDP User Interface Screen if communications between the FPDP and DPEM are compromised.

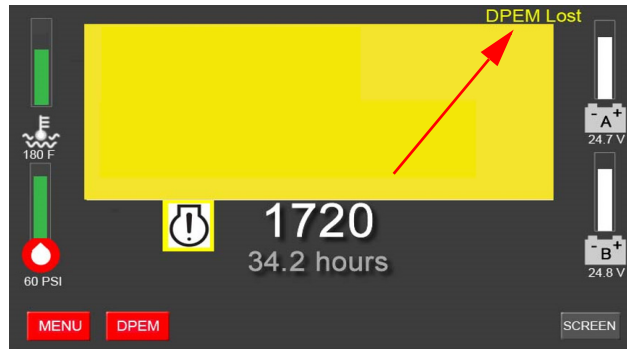

Figure 2-8 DPEM lost fault screen

- **A DPEM alarm** has been activated.
- The pump discharge **pressure is greater than 115%** of the desired pressure in a Variable Speed Pressure Limiting Control (VSPLC)-enabled system (see [Figure 2-13](#)).

2.6.1.2 Red warning indicators

The red ISO symbol (shown in [Figure 2-9](#)) or the red ISO symbol AND a large red box covering the tachometer (shown in [Figure 2-10](#)) indicate an engine malfunction that requires immediate and decisive operator response. The FPDP will display the Red Warning Indicator when the ECM has sensed a fuel system or ECM-specific diagnostic fault. Refer to the Fault Code Chart in the [Fault Codes Section](#) or contact your local Cummins Distributor.

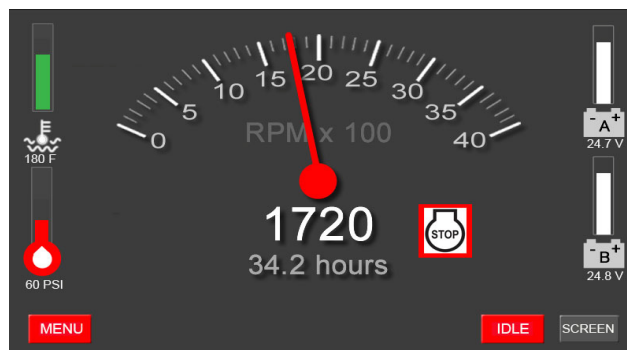

Figure 2-9 Red warning indicator ISO symbol only

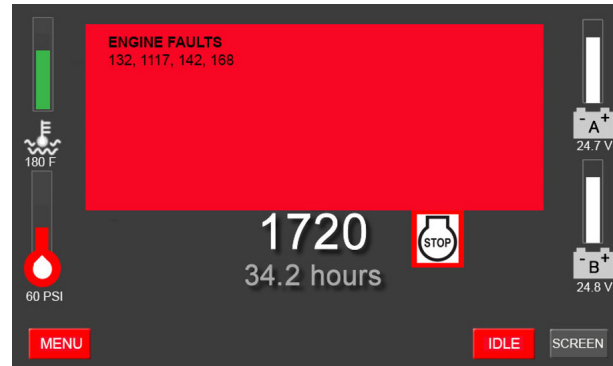

Figure 2-10 Red warning indicator ISO symbol and overlay box

2.6.2 Overspeed warning indicator

As shown in Figure 2-11, “ENGINE OVERSPEED” flashing in red at the top of the FPDP screen indicates that the engine has exceeded its rated RPM and that possible damage to the sprinkler system may occur.

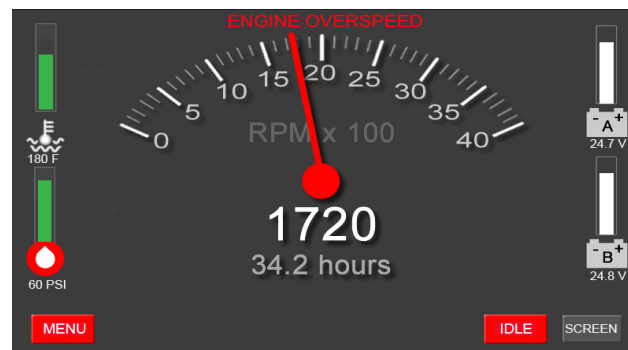

Figure 2-11 Overspeed warning indicator

2.6.3 VSPLC information and warnings

IMPORTANT: VSPLC capability is FM-approved and the fire pump drive engine must be ordered from Cummins as a variable speed engine; specific manufacturing tests are required for fixed and variable speed fire pump drive engines prior to installation.

VSPLC is a controls feature in which the FPDP varies the engine speed in an attempt to maintain a constant pump discharge pressure. The allowable speed range for a VSPLC engine is from low speed idle (LSI) to rated speed where LSI = 1200 RPM on all engines except the CFP15E and CFP30E (in which LSI = 1400 RPM).

The rated speed can be slightly increased or decreased, just as the fixed speed engine setpoint can be, by a Cummins representative.

Description

As shown in [Figure 2-12](#), “VSPLC Active” and the VSPLC discharge pressure will be displayed in white at the bottom of the screen when VSPLC is enabled and active.

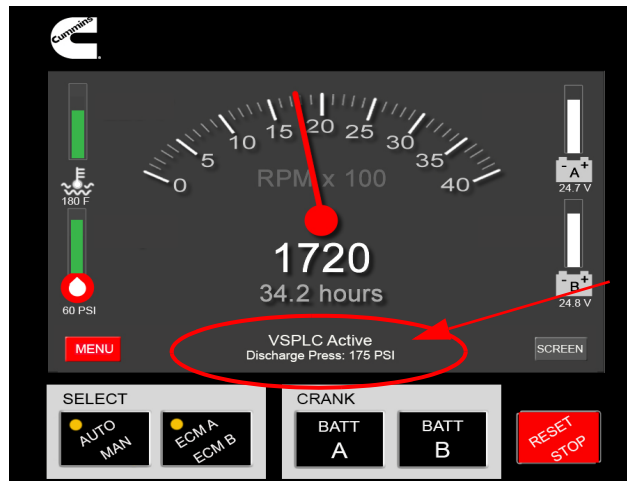

Figure 2-12 VSPLC active screen - white (sample)

If VSPLC is active and the pump discharge pressure is greater than 115% of the setpoint:

- “VSPLC Active” and the VSPLC discharge pressure will be displayed in yellow at the bottom of the screen (shown in [Figure 2-13](#))
- A yellow engine warning lamp icon will also appear on the screen (shown in [Figure 2-13](#))
- A yellow overlay box will appear atop the tachometer signal (the engine speed is still digitally displayed) that states “HIGH PUMP DISCHARGE PRESSURE” to alert the operator to service the engine at the earliest convenience

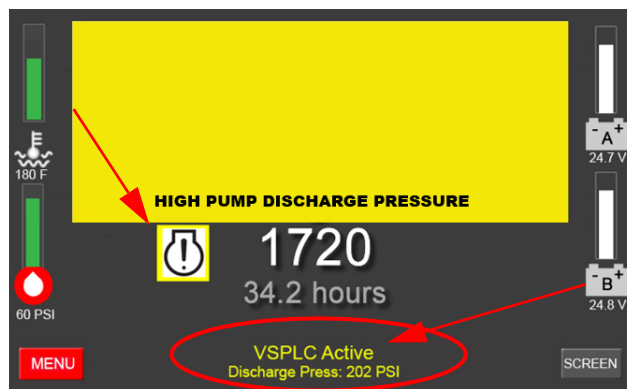

Figure 2-13 VSPLC active screen - yellow (sample)

In order to satisfy fire pump commissioning requirements, the engine will run at fixed speed only when the FPDP is in manual mode with TB-1 off. As shown in [Figure 2-14](#), “VSPLC Inactive” and the VSPLC discharge pressure will be displayed in red at the bottom of the screen when VSPLC is not enabled and/or not active.



Figure 2-14 VSPLC inactive screen - red (sample)

NOTE: If TB-1 is activated from the fire pump controller during this time, the VSPLC mode will activate and control the engine speed based on the pump discharge pressure. “VSPLC Active” and the VSPLC discharge pressure will revert back to white at the bottom of the screen (shown in [Figure 2-12](#)).

2.6.4 DPEM fault screens

When an analog input parameter crosses the alarm setpoint or a switched input is active, the FPDP may display the DPEM fault one of two ways:

- **From the FPDP** - As shown in [Figure 2-15](#), the warning symbol will illuminate and the overlay will activate in yellow with the text of the active fault.

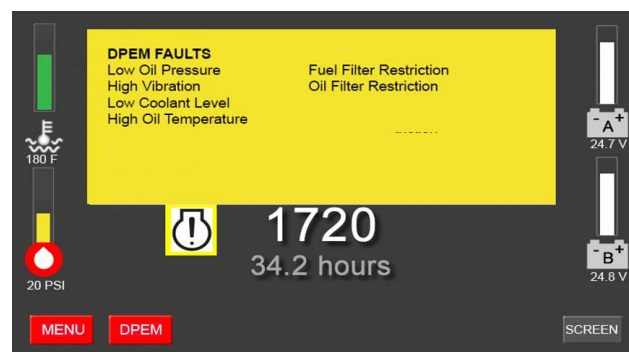

Figure 2-15 DPEM fault screen (sample)

- **From the DPEM/remote location** - The terminal block interface inside of the DPEM has been created for connection to monitor alarms remotely. There is an LED next to each terminal block that will also illuminate if the relay is commanded closed.

Description

Each set of four relays has a common dry contact associated for integration flexibility:

- Terminal Blocks 13-16 (R1-R4) are dedicated to switched inputs, with TB-17 being the common contact
- Terminal Blocks 18-21 (R5-R8) are dedicated to temperature inputs, with TB-22 being the common contact
- Terminal Blocks 23-26 (R9-R12) are dedicated to pressure inputs, with TB-27 being the common contact
- Terminal Blocks 28-31 (R13-R16) are dedicated to additional pressure inputs or J1939 setpoints, with TB-32 being the common contact

As shown in [Figure 2-16](#), “DPEM Lost” will appear on the FPDP screen if communications between the FPDP and DPEM are compromised.



Figure 2-16 DPEM lost fault screen (sample)

2.7 Electronic control module (ECM)

The engine Operation and Maintenance manual provides detailed information about the ECM(s).

A second ECM is installed on electronic engines to satisfy the NFPA 20 requirement for a redundant means of electronic fuel injection. Switching of the sensor inputs and outputs to the respective ECM is controlled through the FPDP either manually (by means of the ECM A/B Selector Switch on the panel) or through an automated process called Autoswitching (refer to the Operation section of this manual for more information on Autoswitching).

NOTE: *Cummins electronically-controlled “engines” normally enable ECMs with derate and shutdown protection. Fire pump drive engines have the derates and shutdowns disabled. Fire pump drive engines will run to destruction, making preventive maintenance even more essential for a fire pump drive engine.*

2.8 Digital panel expansion module (DPEM) (optional)

The digital panel expansion module (DPEM) is an optional electronic device that works in conjunction with the FPDP to provide options for monitoring and alarming custom inputs. As shown in [Figure 2-17](#), the DPEM is housed in a 316 stainless steel enclosure and contains a series of terminal blocks for customer connection to specified alarm points. One DPEM can be configured for any or all of the following:

- Four switched inputs;
- Three temperature inputs;
- One exhaust temperature input;
- Six pressure inputs; and/or
- J1939 parameters (when applicable).

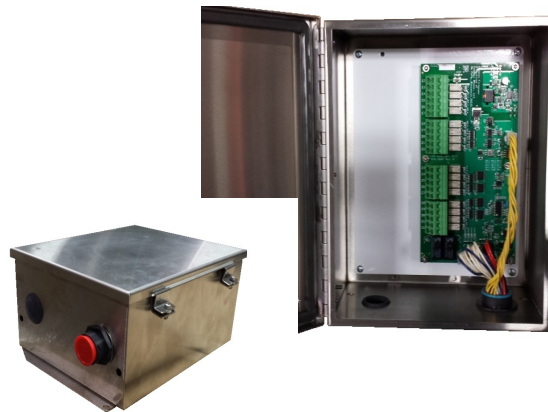

Figure 2-17 Digital programming expansion module (DPEM)

2.9 Fuel supply and drain

As shown in [Figure 2-2](#), the fuel supply and return connections are centrally located on the FPDP side. Refer to the [Engine Data Sheet](#) for the maximum allowable fuel tank supply locations above the fuel pump. Follow published troubleshooting procedures to check fuel restriction measurements.

2.10 High pressure injection (HPI) fuel system

The fire pump drive engine has an HPI electronic fuel system that uses a high-pressure pump and electronic-controlled injectors for precise fuel metering and timing. The system is controlled by the ECM for fueling and timing based on temperature, altitude, pressure, and throttle position.

CAUTION

With the HPI fuel system, fuel priming may be required. See the engine Operation and Maintenance for additional information.

2.11 Fuel cooling system

A fuel cooling heat exchanger maintains a fuel temperature to meet the maximum allowable fuel inlet temperature (160 °F [71 °C]). Performance of the fuel cooling system is critical to engine durability, performance, and emissions compliance.

2.12 Air intake system

The air intake system supplies combustion air to the electronic fire pump drive engine cylinders. The air filters prevent particulate matter from entering the air intake. [Figure 2-18](#) shows how the combustion air is drawn into the system. The turbocharger directs the air through the Charge Air Cooler (CAC) heat exchanger for cooling before entering the cylinders.

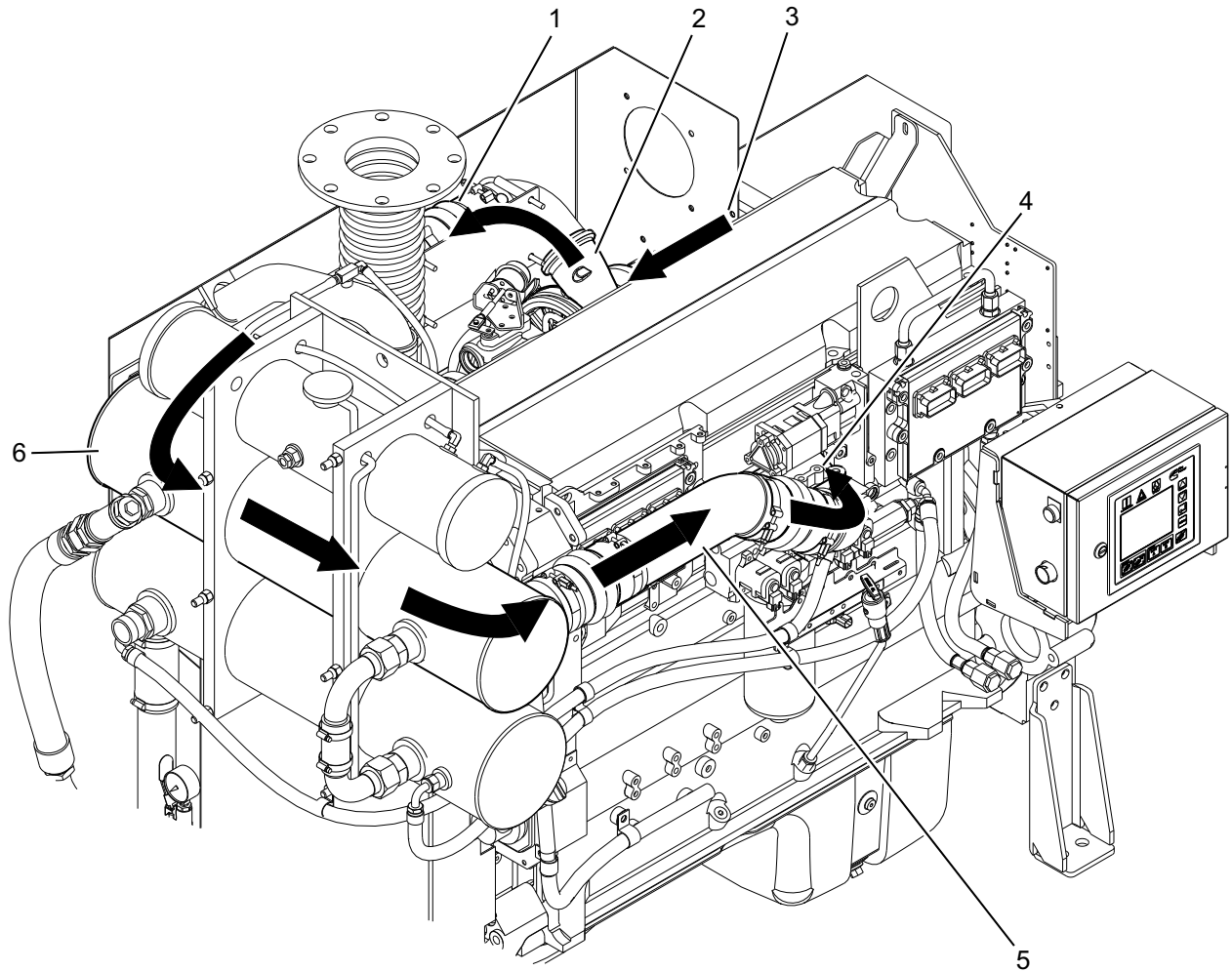

- | | |
|---|-----------------------|
| 1. Air hose to CAC | 4. Intake manifold |
| 2. Turbocharger | 5. CAC pipe |
| 3. Filtered intake air from air cleaner | 6. CAC heat exchanger |

Figure 2-18 Air intake and charge air cooling flow diagram (typical)

2.13 Cooling water system

The following diagrams illustrate a typical cooling loop and the path of water through the engine cooling system. Water entering the cooling system through the cooling water inlet first circulates through the CAC heat exchanger, cooling the compressed air from the turbocharger outlet ducting. The cooled combustion air exits the CAC outlet duct to the engine air intake manifold. The cooling water from the CAC heat exchanger then passes through the engine coolant heat exchanger. The cooling water exits the coolant heat exchanger through a discharge connection.

IMPORTANT: *The cooling water supply must be immediately available when the engine is started.*

IMPORTANT: *Do not operate without a pressure cap.*

NOTE: *When filling with coolant, allow air to bubble out after the initial fill and then add coolant to the maximum level again. Monitor the coolant level after running the engine to ensure that all of the air is out of the system and replace with coolant.*

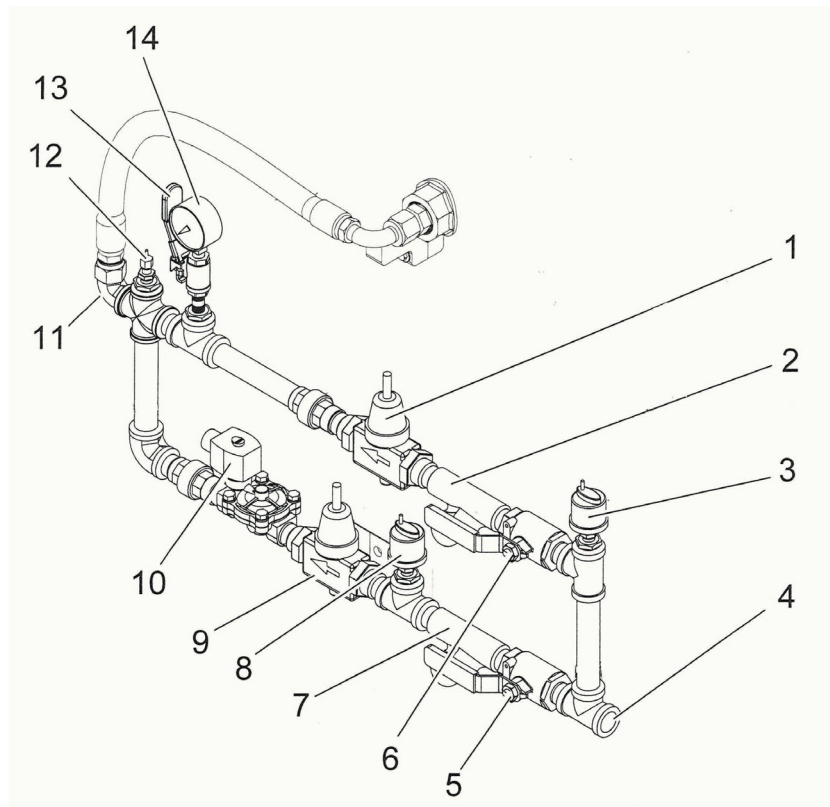

- | | |
|------------------------------------|--|
| 1. Bypass water pressure regulator | 9. Normal water pressure regulator |
| 2. Bypass water strainer | 10. Normal water solenoid valve (where required) |
| 3. Pre-strainer pressure sensor | 11. Outlet to heat exchanger |
| 4. Raw water inlet connection | 12. Temperature sensor |
| 5. Normal water inlet valve | 13. Pressure gauge isolation valve |
| 6. Bypass water inlet valve | 14. Water supply pressure gauge |
| 7. Normal water strainer | |
| 8. Post strainer pressure sensor | |

Figure 2-19 Cooling loop (typical)

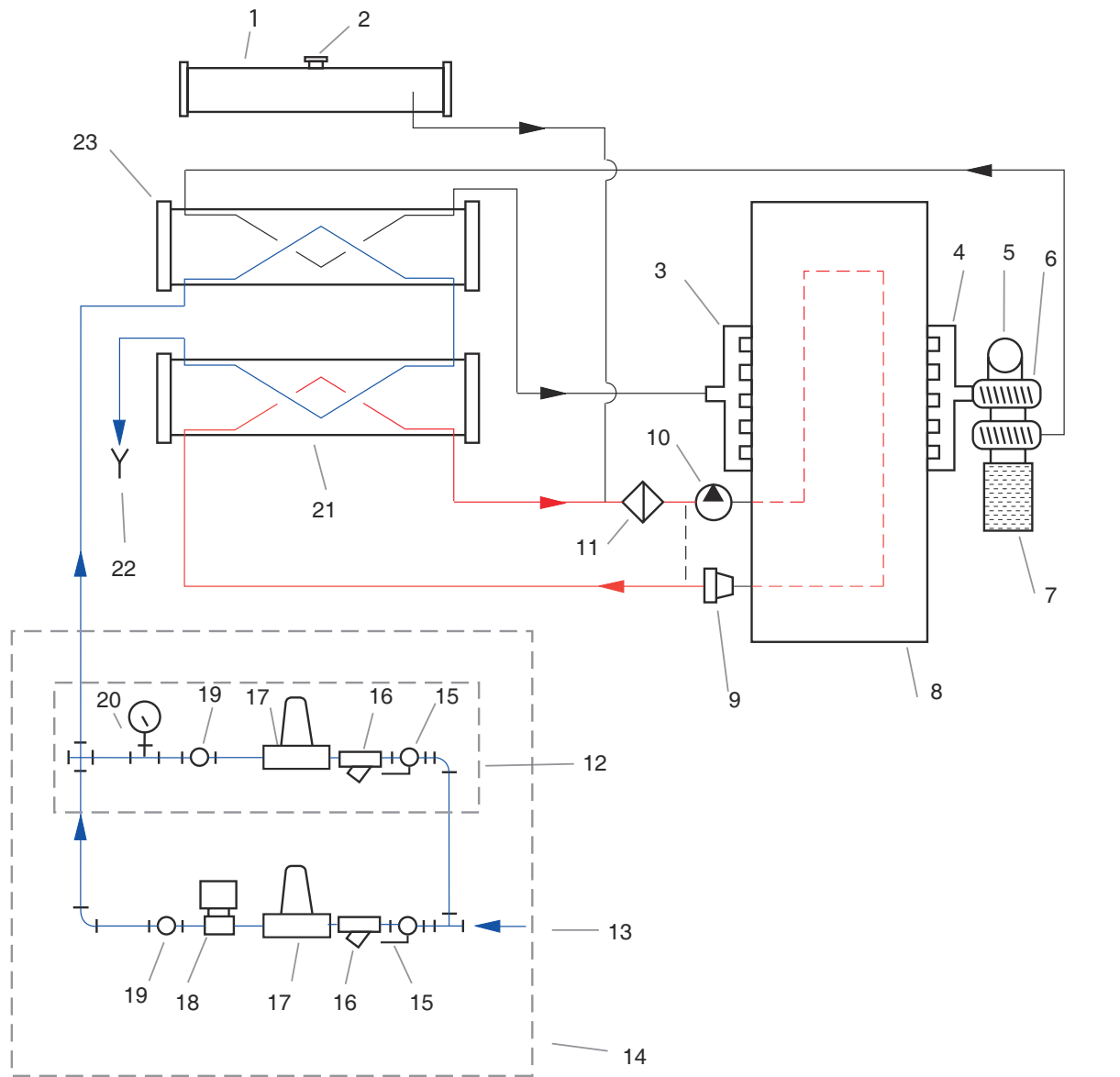

- | | |
|------------------------------|--|
| 1. Coolant surge tank | 13. Raw water inlet connection |
| 2. Coolant pressure/fill cap | 14. Cooling loop |
| 3. Air intake manifold | 15. Manual shut-off valve (2) |
| 4. Exhaust manifold | 16. Raw water strainer (2) |
| 5. Exhaust flex connection | 17. Raw water pressure regulator (2) |
| 6. Turbocharger | 18. Raw water solenoid valve (if required) |
| 7. Air filter | 19. Check valve (2) |
| 8. Engine block | 20. Raw water pressure gauge |
| 9. Thermostat | 21. Coolant/fuel cooling heat exchanger |
| 10. Coolant pump | 22. Raw water discharge connection |
| 11. Coolant filter | 23. Charge air cooler (CAC) heat exchanger |
| 12. Raw water bypass piping | |

Figure 2-20 Engine cooling system flow diagram (typical)

2.14 Engine oil system

The engine oil system lubricates moving internal engine parts (pistons, connecting rods, valves, cam shafts, shafts, and bearings). The oil pump circulates oil from the oil pan, through the oil filter, and into engine areas where friction may develop. Refer to the Cummins engine Operation and Maintenance Manual or Cummins QuickServe Online (QSOL) for additional information.

NOTE: *Typically engine oil has been added during manufacture and testing procedures; however, shipping restrictions can affect whether the oil is maintained in the engine or drained for shipping. Check the oil level at the dipstick. Add oil as necessary to bring the oil level to the H (high) mark on the dipstick.*

2.15 Engine exhaust system

The exhaust system removes engine exhaust from the cylinders after the combustion process. The exhaust discharges from the exhaust manifold, passes through (drives) the turbocharger, and exits through the exhaust connection. Refer to the Cummins engine Operation and Maintenance Manual or Cummins QuickServe Online (QSOL) for additional information.

This page is intentionally left blank.

3 - Installation

3.1 Introduction

This section provides instructions for the initial installation, adjustment, and testing of the Cummins fire pump drive engine. Appropriate portions of this section should be used when returning the engine to operation after overhaul or major maintenance.

3.2 Receiving and handling

Cummins fire pump drive engines are pre-assembled and tested before shipment. Parts not shipped attached to the engine are sometimes shipped individually. The equipment was thoroughly inspected and prepared for shipping before it was turned over to the carrier. Upon receipt of the fire pump drive engine from the shipper:

1. Inspect the equipment for damage that may have occurred in shipping; and
2. Check each item carefully against the shipping manifest or bill of lading.

3.3 Site preparation

The site should be clean and relatively level. Clear the proposed equipment area of overhanging obstructions and obstacles protruding from the floor.



Avoid installation in a dusty or dirty environment. Provide adequate physical protection from other physical damage as may be present in the specific location.

3.4 Drive shaft installation

Drive shaft installation should be done by trained technicians familiar with local, state, and federal codes and regulations.

Refer to National Fire Protection Association (NFPA) 20 for installation and applicable local code requirements and NFPA 25 for inspection, testing, and maintenance requirements.

Follow these steps to install the drive shaft:



Ensure that the lifting device is capable of safely lifting the weight of the engine or the combined weight of the assembled pump base, drive line, and pump. Do not use the engine lifting points for assembly!

1. Ensure that the engine and pump are correctly aligned.
 - a. Ensure that the engine position is centered on the frame side to side within $\pm .76$ mm (.03 in) by measuring outside of the frame side to the engine support leg mounting pad. (Compare the two front engine supports and two back engine supports.)

- b. As shown in [Figure 3-1](#), align the engine center line to the pump center line within $\pm .76 \text{ mm}$ (.03 in).

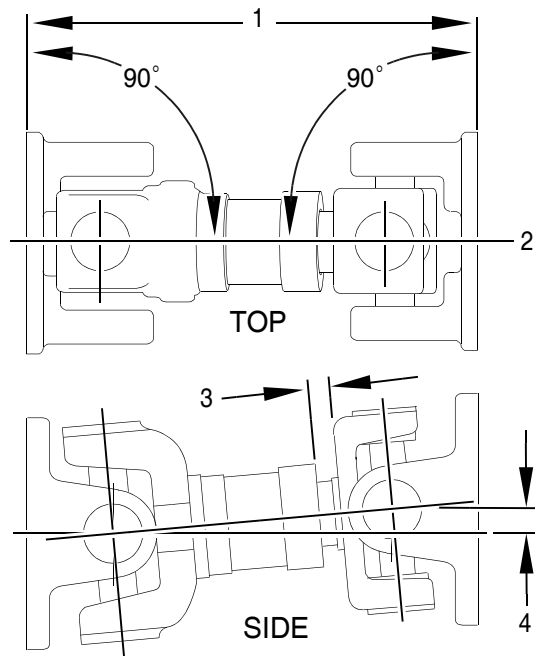

1. Planes must be parallel
2. Align both mounting center lines to $\pm .76 \text{ mm}$ (.03 in)
3. Distance to equal half of total travel
4. $2^\circ \pm 1^\circ$

Figure 3-1 Drive shaft alignment

- c. Ensure that the pump center line to the engine crankshaft center line (in vertical plane) is $2^\circ \pm 1^\circ$.
 - d. Ensure that the drive shaft mounting flanges are parallel.
2. As illustrated in [Figure 3-2](#), lubricate the grease fittings on the drive shaft universal joint.

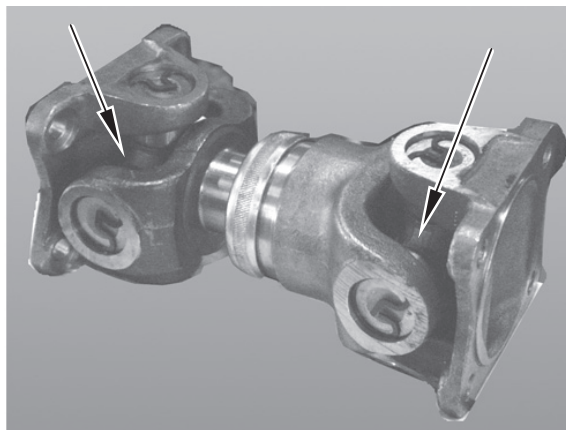

Figure 3-2 Drive shaft universal joint grease fittings

3. Check that the fire pump drive engine is properly installed per the pump manufacturer's specifications.
4. Cummins recommends using a good quality semi-synthetic, molybdenum-fortified National Lubricating Grease Institute (NLGI) #2 lithium complex grease.

NOTE: *Some lubrication loss may occur during transport and storage. It is recommended that the drive shaft be re-lubricated upon installation.*

3.5 Fuel supply installation

NOTE: *It is the responsibility of the customer to provide and install a properly-rated fuel tank per NFPA 20 guidelines.*

To properly install a fuel supply, follow these instructions:

1. Install an elevated no. 2 diesel fuel tank or other fuel supply arrangement which is compatible with American Society of Testing and Materials (ASTM) no. 2 diesel fuel specifications.

NOTE: *The fuel supply line at the fuel tank must be higher than the fuel intake port on the engine fuel pump. Ensure that the fuel system is installed in a safe and effective manner.*

2. Size the fuel tank for the maximum expected full-load engine operation period with the initial fuel level at the minimum level for refueling.
3. Install a fuel return line and route this line to the bottom of the fuel tank in order to minimize the return head.
4. Install a fuel supply line to the fire pump drive engine.

NOTE: *For fuel line specifications, refer to the [Engine Data Sheet](#).*

NOTE: *DO NOT use copper or galvanized pipe for the fuel return or supply lines.*

The fire pump drive engine fuel system has been primed during manufacturing and test procedures. The engine is equipped with an engine driven (gear) fuel pump.

An optional fuel pre-filter and a fuel filter/water separator is integrated into the fuel delivery system of the fire pump drive engine. To ensure that the filter/separator is free of water, open the fuel filter/water separator drain at the bottom of the filter and drain the fuel into a container until no water is present. Dispose of the contaminated fuel in accordance with local environmental regulations.

CAUTION

Due to the precise tolerances of diesel injection systems, it is extremely important that the fuel be kept clean and free of dirt or water. Dirt or water in the system can cause severe damage to both the fuel pump and the fuel injectors.

WARNING

Do not mix gasoline, alcohol, gasohol, ethanol, or methanol with diesel fuel. This mixture will cause severe engine damage or explosion.

CAUTION

Use ONLY no. 2 diesel (ASTM no. 2D) fuel. Any fuel other than no. 2 diesel fuel may affect emission levels. Any adjustment to compensate for reduced performance with a fuel system using alternate fuel is not warrantable.

3.6 Cooling water supply installation

IMPORTANT: *The cooling water supply must be immediately available when the engine is started. Ensure that the supply line valves are in the OPEN position.*

NOTE: *The flow rate of the cooling water should be as great as possible without exceeding the maximum allowable pressure shown in the [Engine Data Sheet](#).*

To install the cooling water supply:

1. Provide a cooling water discharge line at the outlet of the engine coolant heat exchanger and provide a cooling water supply line to the cooling water inlet per the [Engine Data Sheet](#).

NOTE: *The cooling water outlet piping from the heat exchanger should be one pipe size larger than the supply piping.*

2. Check the pressure regulator setting on the cooling loop with water flowing through the heat exchanger. The cooling loop is supplied by Cummins; both water pressure regulators have been set at (or slightly less) water pressure during manufacture and testing:
 - For the CFP5E, CFP7E, CFP9E, CFP15E and CFP23E - 276 kPa (40 psi)
 - For the CFP30E, CFP50 and CFP60E models - 345 kPa (50 psi).

IMPORTANT: *The manual water valves for the normal loop should remain OPEN at ALL times. The manual valves for the bypass loop should be CLOSED during automatic (pump controller) operation. When running, the engine should stabilize between temperatures identified on the [Engine Data Sheet](#). The flow rate may need to be adjusted to maintain the desired engine temperature.*

NOTE: *Excessively cold (4 °C to 23 °C [40 °F to 75 °F]) cooling water flow can cause condensation inside the charge air cooler.*

IMPORTANT: *Continuous operation with low coolant temperature (below 70 °C [158 °F]) or high coolant temperature (above 107 °C [225 °F]) can damage the engine.*

3. Adjust the cooling water based on the water *flow* rather than the water *pressure*. The flow is dependent on the cooling water temperature. Refer to the [Engine Data Sheet](#).
4. To measure the water flow, use an appropriate-sized container to measure the amount of water and the elapsed time of the water to flow from the discharge pipe and then formulate the calculations:

Flow rate = container size/ time to fill container.

Example:

Time to fill a 20 gallon container = 15 seconds.

20 gallons divided by 15 seconds = 1.33 gallons per second.

Multiply by 60 seconds = 80 gallons per minute (gpm) (FLOW RATE)

5. Adjust both pressure regulators to a pressure that will provide a flow rate at or above the specifications listed in the [Engine Data Sheet](#).

CAUTION

When the cooling water piping is installed, adjust both of the pressure regulator setpoints before operating the pump. Damage to the heat exchanger may occur from improperly regulated cooling water supply pressure.

IMPORTANT: Monitor the oil pressure and coolant temperature gauges frequently. Refer to Lubricating Oil System Specifications or Cooling System Specifications in the [Engine Data Sheet](#) for recommended operating pressures and temperatures. Shut off the engine if any pressure or temperature does not meet the specifications.

NOTE: Maximum engine coolant temperature should not exceed the temperature listed on the [Engine Data Sheet](#). The coolant expansion pressure/fill cap must meet the minimum pressure of 10 kPa (15 psi).

The engine coolant system contains a mixture of at least 50% antifreeze and 50% water. The coolant level should be maintained so it is visible in the coolant level sight gauge.

3.7 Battery installation

The minimum recommended Society of Automotive Engineers (SAE) reserve capacity (RC) and SAE cold cranking ampere (CCA) values for a particular engine can be found on the [Engine Data Sheet](#). RC and CCA definitions can be found in SAE Standard J537. Refer to NFPA 20 and FM 1333 standards for additional battery installation information.

WARNING

Battery electrolyte (sulfuric acid) is highly caustic and can burn clothing and skin. Wear impervious neoprene gloves and safety goggles, or a full face shield, when working with the batteries.

IMPORTANT: Batteries must meet the requirement listed in the electrical system specifications. Batteries may be supplied by Cummins as an option, or may be supplied by the customer.

WARNING

Batteries can emit explosive gases during charging. Always ventilate the compartment before servicing the batteries. To avoid arcing, remove the negative (-) battery cable first and attach the negative (-) battery cable last.

To properly install the batteries:

1. As shown in the following diagrams, install the battery cable kit or equivalent customer-supplied wiring. Install battery sets in a well-ventilated or otherwise protected location.

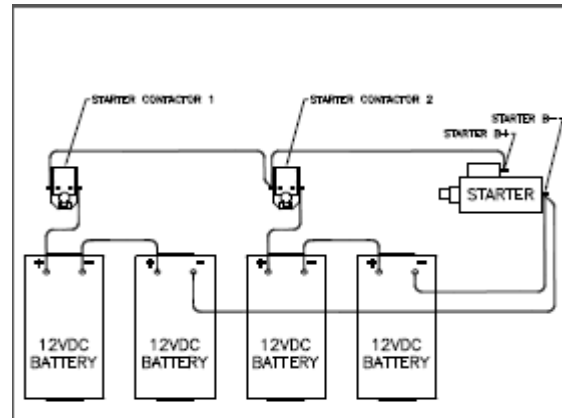
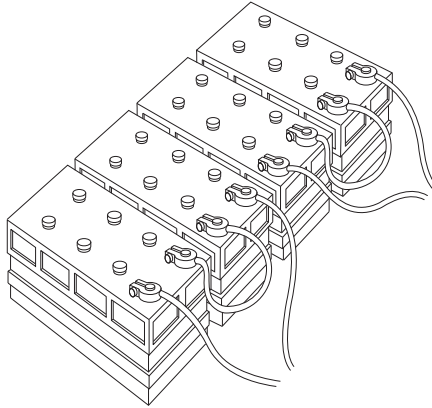

Figure 3-3 Series battery connection 24 VDC

2. Provide adequate room for servicing or replacing the batteries. Provide protection from extremes of temperature and weather.
3. Locate the batteries near the engine or increase the size of the conductors as required by applicable codes. Ensure that the batteries are configured properly for 24 VDC standard operations.
4. Check the battery cables and connections.

NOTE: Coat the terminals with petroleum jelly to prevent corrosion. Install the cables and tighten the battery connections.

3.8 Signal and control installation

The fire pump controller wires must be connected to the terminal blocks (TBs) on the FPDP Interface Terminal Strip and on the Battery Charger Interface. To complete the signal and control installation:

1. Ensure that the fire pump controller is properly installed and configured per the manufacturer's instructions.
2. Complete the fire pump controller wiring (customer-supplied) per the manufacturer's instructions.
3. Ensure electrical continuity and adequate insulation resistance for the installed wiring. Refer to the Operation - Engine Setup Screen section to conduct a Terminal Block Test from the FPDP.

3.8.1 FPDP interface terminal strip

As shown in [Figure 3-4](#), the TBs between the fire pump controller and the fire pump driver are standard UL and FM controller terminals and follow a direct one-to-one correspondence (some TBs are optional):

- **TB-1 [Run Solenoid Circuit]:** This B+ signal is necessary for fire pump operations while in the FPDP is in AUTO (automatic) mode. The Electronic Control Module (ECM) keyswitch/Fuel Shutoff (FSO) and raw water solenoid are activated when voltage is present at TB-1. When TB-1 is removed while the engine is running, the FPDP will command electronic engines to idle for up to three minutes.
- **TB-2 [Crank Termination Switch]:** This B+ signal is provided by the FPDP to inform the pump controller that the engine is running. Crank Termination indicates that the engine has started and that the crank command from the fire pump controller should stop immediately.
- **TB-3 [Overspeed Switch]:** This B+ signal is provided by the FPDP when the engine speed has exceeded 115% of the rated engine speed. When overspeed occurs, the ECM keyswitch or FSO outputs and the raw water cooling loop solenoid are immediately deactivated in an attempt to stop the fire pump drive engine. The FPDP will not allow the engine to be restarted until after the overspeed alarm has been reset.
- **TB-4 [Low Lubricant Pressure Switch]:** A ground path is provided by the FPDP when the oil pressure has dropped below the 16 psi (110 kPa) setpoint when the engine is running. A ground path is also provided to indicate low oil pressure when the engine is NOT running.

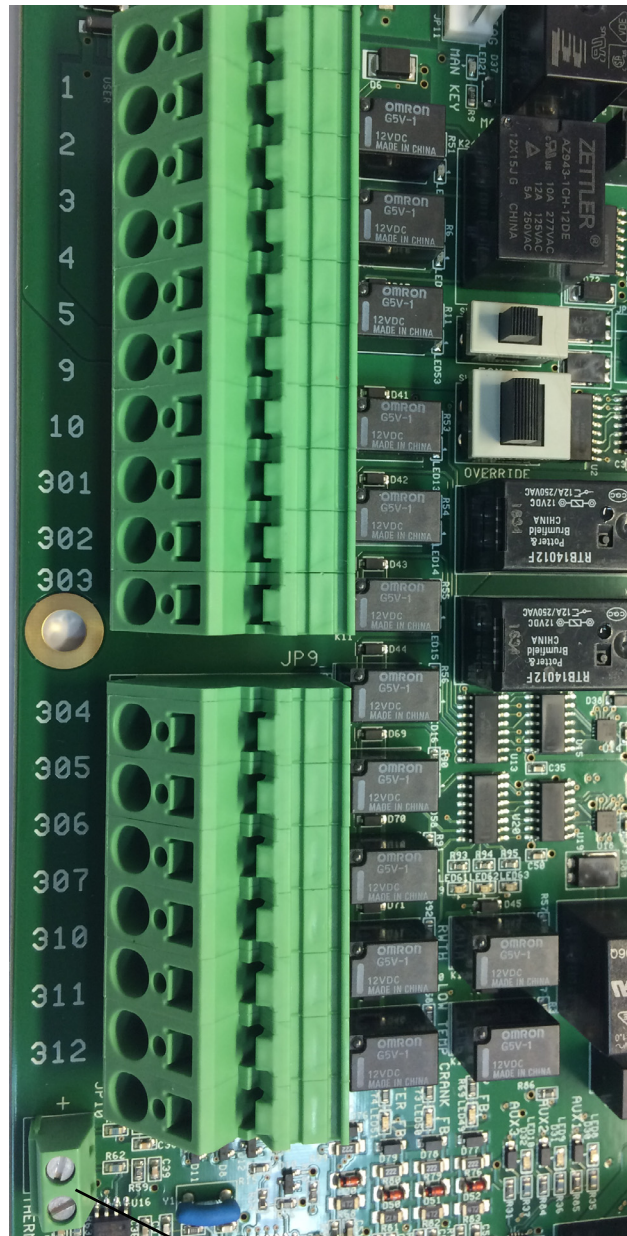

Thermocouple input

Figure 3-4 FPDP interface terminal strip

- **TB-5 [High Engine Temperature Signal]:** A ground path is present when the engine is running and the coolant temperature is at or above 212 °F (100 °C).
- **TB-9 [Main Battery Contactor One Coil or Battery Relay One Coil]:** This B+ signal is driven from the fire pump controller to contactor A when desiring to crank the engine from Battery A. Current in this circuit shall not exceed 10A continuous.

-
- TB-10 [**Main Battery Contactor Two Coil or Battery Relay Two Coil**]: This B+ signal is driven from the fire pump controller to contactor B when desiring to crank the engine from Battery B. Current in this circuit shall not exceed 10A continuous.
 - TB-301 [**ECM Switch**]: A ground path is provided by the FPDP when the engine is operating on ECM B.
 - TB-302 [**Fuel Injection Malfunction (FIM)**]: A ground path is provided by the FPDP when either of the ECMs triggers a fault code which can affect the performance of the Fuel Injection System. See the Troubleshooting section for possible fault causes and solutions.
 - TB-303 [**ECM Warning**]: A ground path is provided by the FPDP when a single ECM has been diagnosed as failed.
 - TB-304 [**ECM Failure**]: A ground path is provided by the FPDP when both ECMs have been diagnosed as failed.
 - TB-305 [**Custom Output 1**]: A ground path is provided by the FPDP when the custom alarm is configured and activated.

NOTE: *If an Air Shutoff Valve is purchased, TB-305 is reserved for valve position feedback.*

- **Type K Thermocouple Input - optional:** The screws to the Type K thermal couple input may be loosened for installation of an exhaust temperature.
- TB-306 [**Custom Output 2**]: A ground path is provided by the FPDP when the custom alarm is configured and activated.
- TB-307 [**Custom Output 3**]: A ground path is provided by the FPDP when the custom alarm is configured and activated.
- TB-310 [**Raw Water High Inlet Temperature**] - *not applicable on radiator-cooled models* - A ground path is provided by the FPDP when high raw water temperature is sensed.
- TB-311 [**Clogged Raw Water Cooling Loop Strainer**] - *not applicable on radiator-cooled models* - A ground path is provided by the FPDP when the raw water supply restriction is sensed.
- TB-312 [**Low Engine Temperature Signal**]: A ground path is provided by the FPDP when the engine coolant falls below 100 °F (37.8 °C).

3.8.2 Battery charger interface

As shown in [Figure 3-5](#), the Battery Charger Interface provides power to the fire pump controller, as well as provides charging current to the fire pump drive engine batteries. The Battery Charger Interface includes:

- TB-6 [**Battery A Positive**]: The fire pump controller senses Battery A charge state and charges Battery A through TB-6.
- TB-8 [**Battery B Positive**]: The fire pump controller senses Battery B charge state and charges Battery B through TB-8.
- TB-11 [**Battery A and Battery B Negative**]: The fire pump controller uses TB-11 as a ground reference for incoming power, as well as to charge the fire pump drive engine batteries.

NOTE: *This is not intended to create a fully isolated battery negative or ground system. Current in each terminal block shall not exceed 30 amperes continuous.*

To complete the battery signal connections:

1. Provide the initial charge on the redundant batteries per the battery charger's instructions.
2. Check that both voltmeters on the FPDP indicate the approximate battery voltage.

NOTE: *Both sets of batteries can be used for starting the engine in the event that one set is low.*

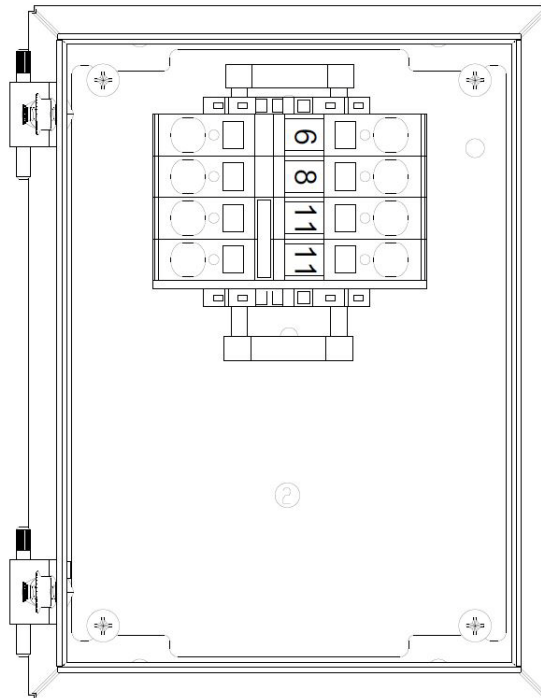

Figure 3-5 Battery charger interface

3.9 Coolant system preparation

The fire pump drive engine cooling and lubrication system was initially filled during manufacture and testing. To properly prepare the coolant system:

CAUTION

Ensure that all coolant systems have been filled to the proper level before operation by checking the coolant level sight gauge on the surge tank.

1. Inspect the engine coolant hoses and hose clamps and ensure that all coolant hoses and clamps are properly installed and water tight.
2. Ensure that the engine coolant heater maintains an engine coolant temperature of 49 °C (120 °F) or above.
3. Ensure that coolant is present in the engine coolant heater before plugging the heater element into a dedicated circuit. Add coolant, if necessary.

-
4. Inspect the heat exchanger weekly for external damage and contamination.

NOTE: Contamination of the heat exchanger will affect the ability of the cooling system to transfer heat and properly cool the engine and intake manifold.

5. Add coolant, if necessary:

NOTE: Supplemental engine coolant should be a mixture of 50% ethylene glycol antifreeze and 50% water to avoid engine damage. For additional information, refer to the antifreeze information found in the Maintenance section.

- If the engine *IS* equipped with a sight level gauge, ensure that the engine coolant level is visible at the center of the sight level gauge. Add coolant as required. **DO NOT OVERFILL!**
- If the engine *IS NOT* equipped with a sight level gauge, fill the cooling system with coolant to the bottom of the fill neck. Do not fill above the bottom of the fill neck.

6. Re-install the pressure/fill cap.

▲ WARNING

Do not remove the pressure/fill cap from a hot engine. Wait until the coolant temperature is below 50 °C (122 °F) before removing the pressure/fill cap. Heated coolant spray or steam can cause personal injury.

3.10 Charge air cooler (CAC) inspection

The charge air cooler (CAC) system reduces the temperature of the compressed combustion air from the turbocharger before entering the air intake manifold.

Inspect the CAC piping and hoses for loose/missing hose clamps, hose punctures, leaking manifold seals, or corrosion. Torque the hose clamps to the recommended torque value. Refer to the Engine Specification Sheet.

3.11 Lubricating oil system preparation

The fire pump drive engine and turbocharger were initially lubricated during manufacture and testing. To prepare the lubricating oil system for operation:

1. Check the oil level using the dip stick before operating the fire pump drive engine.
2. Fill the oil fill port to the “H” mark on the dipstick with lubricating oil.

For those models (CFP9E, CPFP11E, CFP15E, and CFP23E) equipped with an oil level gauge, it may be necessary to adjust the gauge:

1. Ensure the engine oil is at the low level of the oil dipstick.
2. Start the engine.
3. Adjust the oil level gauge until it alarms.
4. Stop the engine.
5. Fill the oil fill port to the “H” mark on the dipstick with lubricating oil.

NOTE: Do not use special “break-in” lubricating oils for new or rebuilt Cummins engines. Use the same type of oil during the “break-in” as used during normal operation.

CAUTION

Some regulatory and shipping restrictions may require that all lubricants, fuels, and coolants be drained for transport. Ensure that all cooling and lubrication systems have been filled to the proper level before operation.

NOTE: Using multi-viscosity lubricating oil can improve oil consumption control and improve engine cranking in cold temperatures while maintaining lubrication at high operating temperatures. Cummins recommends Premium Blue® 15W-40 oil for most climates.

CAUTION

Ensure that all cooling and lubrication systems have been filled to the proper level before operation.

3.12 Variable Speed Pressure Limiting Control (VSPLC) preparation

NOTE: VSPLC capability is on electronic engines, only. This section is not applicable to mechanical engines.

As shown in [Figure 3-6](#), to prepare the fire pump drive engine for VSPLC capability, connect a 1/2 inch (12.7 mm) inside diameter pressure sensing line to the transducer or Cummins-supplied flexible hose located under the FPDP and the other end to between the pump discharge flange and the discharge check valve.

IMPORTANT: Cummins recommends that provisions be made within the VSPLC connection line to account for any engine vibration and movement.

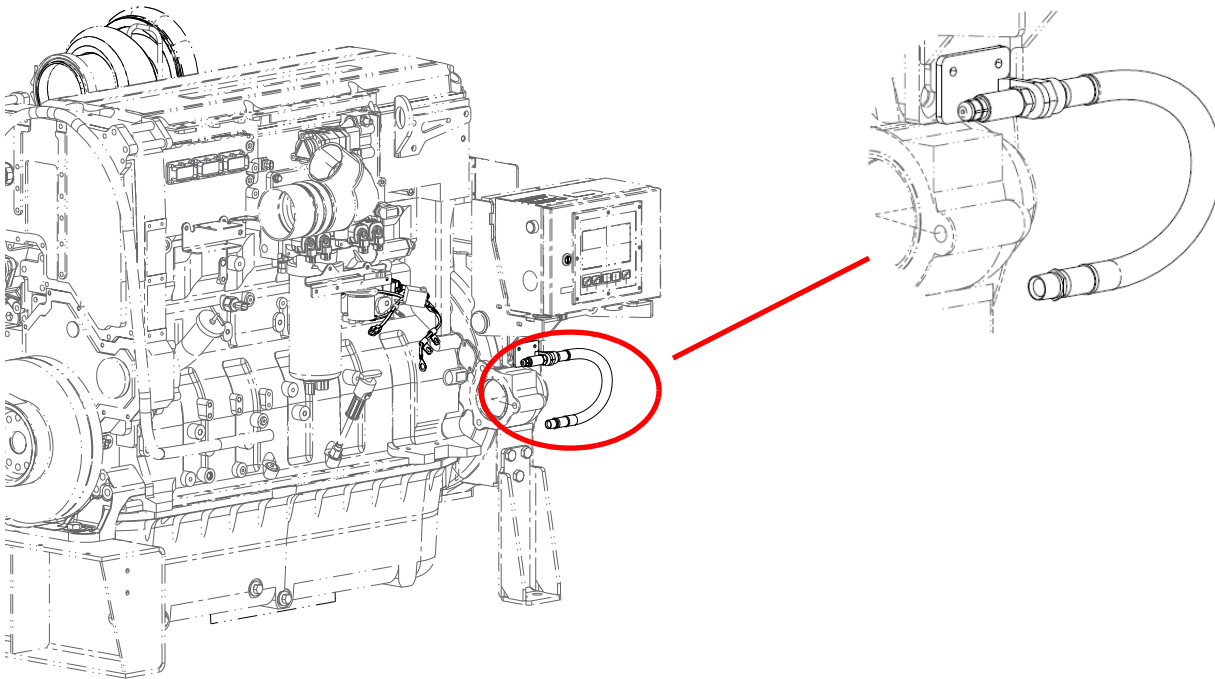

Figure 3-6 VSPLC pressure sensing connection

3.13 Pre-start inspections

Prior to starting the fire pump drive engine for the first time, perform a visual inspection:

1. Check that there is no apparent damage and that all components are installed.
2. Check that the drive belt is properly installed.
3. Check that all hoses and tubes are properly installed.
4. Check that all electrical connections are properly installed.
5. Check that the fire pump drive engine is properly installed per the pump manufacturer's instructions, is correctly aligned, and is free to rotate.
6. Lubricate the grease fittings on the auxiliary drive shaft.

NOTE: Use the same type of oil as used in normal operation. Cummins recommends Premium Blue[®] 15W-40 oil for most climates.

WARNING

Before operating the equipment, complete all safety checks, remove all tools and foreign objects from the equipment, and ensure that all guards are in place and securely fastened. Alert area personnel that the equipment will be starting. Unintentional equipment start-up or contact with exposed or moving components can cause personal injury or equipment damage.

3.14 Engine monitoring

When the engine starts, it is important to monitor the displays:

1. Immediately check that water flow is established through the coolant heat exchanger. The water flow should be established immediately, but some delay may occur before the flow exits the heat exchanger drain connection.

NOTE: Ensure that cooling water is flowing and the water pressure shown on the local pressure gauge is no more than 414 kPa (60 psi). The minimum cooling water flow rate is identified in the [Engine Data Sheet](#).

2. Ensure that the engine operating temperature stabilizes between applicable ranges as identified in the [Engine Data Sheet](#).
3. Operate the engine for eight to ten minutes.
4. Inspect the engine for leaks, unusual noises, or other indications of incorrect operation.
5. While running the engine, look for the following signals during operation and field testing:

CAUTION

If the oil pressure is not displayed on the gauge or if the low oil pressure message is displayed within fifteen seconds, STOP THE ENGINE IMMEDIATELY! Continued operation without proper lubrication will cause engine damage.

- Low engine lubricant pressure
- High engine coolant temperature

- Low engine temperature
 - High raw water temperature
6. Shut off the engine by pressing and holding the overspeed **RESET/STOP** switch.
 7. Shortly after the engine stops, check that the water flow stops automatically.
 8. Correct any problems found during the inspection before proceeding.
 9. Check the engine lubricating oil level at the dip stick. Add oil, if necessary.
 10. Check the coolant expansion tank level. Add coolant, if necessary.
 11. Check the cooling water strainers. Clean the strainers according to the maintenance schedule in [Section 5 - Maintenance](#).
 12. Perform engine speed control and safety system tests per the instructions in [4 - Operation](#).

3.15 Start-up validation

The required installation tests are outlined in the NFPA 20 Standards and shall be performed to validate automatic and manual operational requirements for field acceptance testing. Visit <https://www.cummins.com/engines/fire-pump-drives/registration-and-warranty> to download the Start-up inspection checklist.

NOTE: *The maximum engine speed should only be altered by a Cummins technician.*

These instructions should be used during the commissioning of a new diesel fire pump drive engine to validate the alarming between the Cummins FPDP and the pump controller. The various testing techniques detailed below will safely validate the connections between these two devices, the pump controller's response to the alarm, and the FPDP's internal ability to activate the alarm. Unless otherwise instructed, conduct all tests with the FPDP in **Auto** mode and the pump controller in **Manual** mode. The tests apply to both Electronic Control Module (ECM) A and ECM B

To access the Analog Values screen, press **MENU** and then **ANALOG VALUES**. If an alarm does not register on the pump controller as expected, refer to the Troubleshooting instructions at the end of this document.

VSPLC units must be exercised to create their maximum pressure during commissioning. This can be easily completed by switching the unit into **Manual** mode on the FPDP. A dialog box will appear on the screen alerting the user that the engine will run at a constant rated speed. Once in **Manual** mode, simply start the engine from the FPDP, and the engine will run at its rated maximum speed. *NOTE: TB-1 must be inactive for the engine to run at a constant rated speed, otherwise it will run in VSPLC mode.*

To access the **Terminal Block Test** menu to test the Power Board circuitry and connection to the pump controller:

1. Press MENU



2. Select ENGINE SETUP

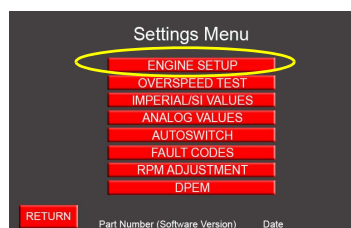

3. Enter "806" and press SUBMIT

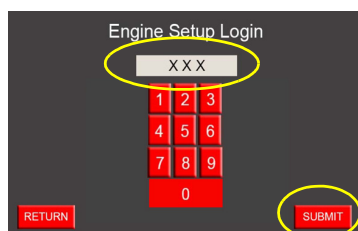

4. Select TERMINAL BLOCKS

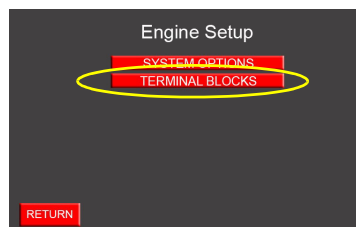

A typical Terminal Block Test screen is shown below. Follow the detailed instructions in the next section to perform the start-up validation.

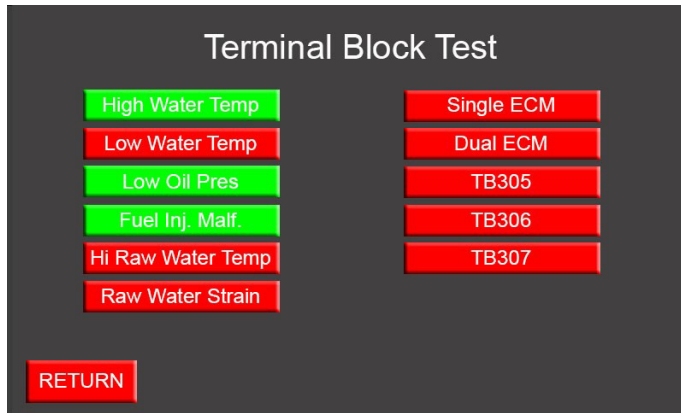

Figure 3-7 Typical Terminal Block Test screen

3.15.1 High Water Temp

Simulate a high coolant temperature condition (TB-5 - High Engine Temperature).

TEST	With the engine running from the pump controller and the FPDP in Auto mode, press the High Water Temp soft key (when the button is green, the alarm will activate) to simulate a high coolant temperature alarm sent from the FPDP to the pump controller.		
	Validate that the high coolant temperature alarm is active (LED is lit) on the pump controller.	VERIFY	The pump controller alarm indicates that a high engine temperature condition has occurred.
	After the alarm has been verified, reset the alarm on the pump controller by turning the pump controller off and then on.		

3.15.2 Low Water Temp

Simulate a low engine temperature condition (TB-312 – Low Engine Temperature).

NOTE: The *LOW ENGINE TEMPERATURE* alarm can be conveniently tested while the engine is cold using the *Primary Method*. If the engine is warm, use the *Alternate Method*.

Primary Method (If engine is cold)

TEST	Start and run the engine from the pump controller.	VERIFY	The pump controller alarm indicates that a low engine temperature condition has occurred.
	During the first few minutes of engine operation while the Water Temp (shown on the Analog Values screen) is less than 110 °F, the low engine temperature alarm should be active on the pump controller.		

Alternate Method (If engine is warm) - simulation from the Terminal Block Test screen

TEST	With the engine running from the pump controller and the FPDP in Auto mode, press the Low Water Temp soft key (when the button is green, the alarm will activate) to simulate a low engine temperature alarm sent from the FPDP to the pump controller.	VERIFY	The pump controller alarm indicates that a low engine temperature condition has occurred.
	Validate that the low engine temperature alarm is active (LED is lit) on the pump controller.		
	After the alarm has been verified, reset the alarm on the pump controller by turning the pump controller off and then on.		

3.15.3 Low Oil Pres

Simulate a low engine temperature condition (TB-4 – Low Oil Pressure).

TEST	With the engine running from the pump controller and the FPDP in Auto mode, press the Low Oil Pres soft key (when the button is green, the alarm will activate) to simulate a low oil pressure alarm sent from the FPDP to the pump controller.	VERIFY	The pump controller alarm indicates that a low oil pressure condition has occurred.
	Validate that the low oil pressure alarm is active (LED is lit) on the pump controller.		
	After the alarm has been verified, reset the alarm on the pump controller by turning the pump controller off and then on.		

3.15.4 Fuel Inj. Malf.

Simulate a fuel injection malfunction (TB-302 - Fuel Injection Malfunction (FIM)).

TEST	With the engine running from the pump controller and the FPDP in Auto mode, press the Fuel Inj. Malf. soft key (when the button is green, the alarm will activate) to simulate a fuel injection malfunction alarm sent from the FPDP to the pump controller.		
	Validate that the fuel injection malfunction alarm is active (LED is lit) on the pump controller.	VERIFY	The pump controller alarm indicates that a fuel injection malfunction condition has occurred.
	After the alarm has been verified, reset the alarm on the pump controller by turning the pump controller off and then on.		

3.15.5 Hi Raw Water Temp

Simulate a high raw water temperature alarm sent from the FPDP to the pump controller (TB-310 - Raw Water High Inlet Temperature).

NOTE: *The Raw Water Temperature High alarm can be validated in two different ways. The first way allows for a more thorough evaluation of the system.*

Primary Method - Grounding the Sender

TEST	With the engine running from the pump controller and the FPDP in Auto mode, ground the raw water temperature sender by creating continuity between the sender terminal and the bare metal on the raw water cooling loop.		
	With the sensor grounded, the FPDP will display a high Cooling Loop Temp (shown on the Analog Values screen) and the high raw water temperature alarm should be active on the pump controller.	VERIFY	The pump controller alarm indicates that a high raw water temperature condition has occurred.

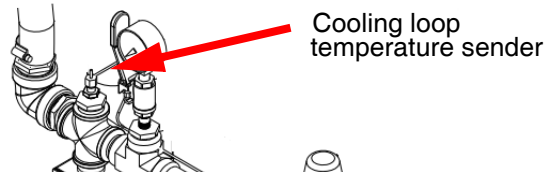

Alternate Method - simulation from the Terminal Block Test screen

TEST	With the engine running from the pump controller and the FPDP in Auto mode, press the Hi Raw Water Temp soft key (when the button is green, the alarm will activate) to simulate a high raw water temperature alarm sent from the FPDP to the pump controller.		
	Validate that the high raw water temperature alarm is active (LED is lit) on the pump controller.	VERIFY	The pump controller alarm indicates that a high raw water temperature condition has occurred.
	After the alarm has been verified, reset the alarm on the pump controller by turning the pump controller off and then on.		

3.15.6 Raw Water Strain

Simulate a low raw water flow alarm sent from the FPDP to the pump controller (TB-311 - Clogged Raw Water Cooling Loop Strainer).

NOTE: This alarm can be validated in two different ways. The first way allows for a more thorough evaluation of the system.

Primary Method - close the raw water cooling loop primary manual shutoff valve

TEST	Begin with the engine running from the pump controller and the FPDP in Auto mode.	VERIFY	The pump controller alarm indicates that a low raw water flow condition has occurred.
	Simulate a clogged raw water strainer by throttling (partially closing) the raw water cooling loop Primary Manual Shutoff Valve.		
	With the valve partially closed, the FPDP will display a high Diff Press Post: (shown on the Analog Values screen) and the low raw water flow alarm should be active on the pump controller.		
	After the alarm has been verified, re-open the raw water cooling loop Primary Manual Shutoff Valve and reset the alarm on the pump controller by turning the pump controller off and then on.		

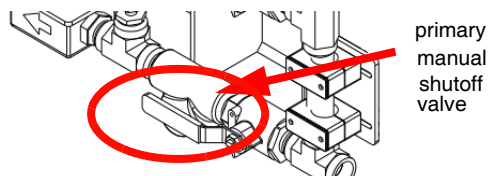

Alternate Method - simulation from the Terminal Block Test screen

TEST	With the engine running from the pump controller and the FPDP in Auto mode, press the Raw Water Strain soft key (when the button is green, the alarm will activate) to simulate a low raw water flow alarm sent from the FPDP to the pump controller.	VERIFY	The pump controller alarm indicates that a low raw water flow condition has occurred.
	Validate that the low raw water flow alarm is active (LED is lit) on the pump controller.		
	After the alarm has been verified, reset the alarm on the pump controller by turning the pump controller off and then on.		

3.15.7 TB-303/304 - ECM Warning/ECM Failure

NOTE: *Single ECM Warning and ECM Failure can be conveniently tested while the engine is off using the primary method. If the engine is running, use the alternate method, although this will not activate the autoswitch routine.*

Primary Method (engine off)

TEST	With the engine off, place the pump controller in Manual or Test mode and the FPDP in Auto mode.		
	<p>Press and hold the Engine Stop button on the upper left side of the FPDP. This will manually cut switched power to the ECMs.</p> <p>The FPDP will detect the loss of data link communications from the ECM and report an ECM failure to the pump controller.</p> <p>The FPDP ECM A/ECM B button will automatically switch from ECM A to ECM B (the LED will switch from ECMA to ECMB).</p> <p>Note: Once the FPDP switches to ECM B, the ECM failure alarm should become active.</p>	VERIFY	The pump controller alarm indicates that an ECM failure condition has occurred.
	With the Engine Stop button still held, the FPDP will diagnose a failure of the alternate ECM. The ECM failure alarm should be activated on the pump controller.	VERIFY	The pump controller alarm indicates that an ECM failure (for ECM B) condition has occurred.

NOTE: *Repeat this test by starting with ECM B active and then allowing the FPDP to transition from ECM B to ECM A during the autoswitch routine.*

Alternate Method on next page

Alternate Method (engine running) - simulation from the Terminal Block Test screen

TEST	<p>With the engine running from the pump controller and the FPDP in Auto mode (the FPDP ECM A / ECM B button should indicate ECM A), press the Single ECM soft key (when the button is green, the alarm will activate) to simulate an ECM failure alarm sent from the FPDP to the pump controller.</p>	VERIFY	
	<p>Validate that the ECM failure alarm is active (LED is lit) on the pump controller. The FPDP ECM A / ECM B button will automatically switch from ECM A to ECM B (the LED will switch from ECMA to ECMB). Note: Once the FPDP switches to ECM B, the TB301 alarm should become active.</p>		
	<p>Press the Dual ECM soft key (when the button is green, the alarm will activate) to simulate an ECM failure alarm (for ECM B) sent from the FPDP to the pump controller.</p>	VERIFY	
	<p>After the alarm has been verified, reset the alarm on the pump controller by turning the pump controller off and then on.</p>		

NOTE: Repeat this test by starting with ECM B active and then allowing the FPDP to transition from ECM B to ECM A during the autoswitch routine.

3.15.8 TB-305-307 - Custom Outputs - simulation from the Terminal Block Test screen

NOTE: *Not every engine will have custom switched inputs available for testing, use this section as required only.*

TEST	With the engine running from the pump controller and the FPDP in Auto mode, press the applicable TB305 , TB306 , or TB307 soft key (when the button is green, the alarm will activate) to simulate an applicable custom alarm sent from the FPDP to the pump controller.		
	Validate that the custom alarm is active (LED is lit) on the pump controller.	VERIFY	The pump controller alarm indicates that a custom alarm condition has occurred.
	After the alarm has been verified, reset the alarm on the pump controller by turning the pump controller off and then on.		

3.15.9 TB-301 - ECM Switch

TEST	With the engine off and ECM A active, press the ECM A / ECM B button one time to switch to ECM B (the LED will switch from ECMA to ECMB).		
	Start and run the engine from the pump controller	VERIFY	The pump controller alarm indicates that the ECM is in the alternate position - that the alternate ECM is active.

3.15.10 TB-3 - Overspeed Switch

Verify the firmware version by pressing the Menu button from the FPDP main screen. The firmware version will be visible on the bottom of the screen in the center.

Run this test according to the 'Alternate Method' with the engine **OFF**, the FPDP in **Auto** mode, and the pump controller **OFF**, if one or more of the below are true:

- It is not desired or possible to momentarily cause an actual overspeed condition.
- The engine has a firmware version prior to 1.55.
- The engine has an air shutoff valve.

IMPORTANT: *An Overspeed Test performed with the engine running on a fire pump drive engine with an air shutoff valve may cause damage to the engine.*

The engine speed is listed in the following 'Overspeed Exclusions' table:.

Overspeed Exclusions

Model	Speed Rating
CFP5E	2600 RPM
CFP7E	2600 RPM
CFP9E/CFP9E HHP	2300 RPM
CFP15E	2250 RPM
CFP23E	2100 RPM
CFP30E	2100 RPM
CFP60E	1800 RPM

Primary Method (engine running)

TEST	Begin with the engine running from the pump controller and the FPDP in Auto mode. Press MENU > OVERSPEED TEST > Run .	
	A dialog box will appear alerting the user that the engine will ramp to an overspeed condition. If it is safe to do so, proceed with the test and select Yes . If not, select No and see the note below.	
	VERIFY	When the timer expires, "ENGINE OVERSPEED" written in red will flash at the top of the FPDP screen until a reset occurs. The pump controller alarm indicates that an overspeed condition has occurred.
	VERIFY	The engine will shut down once the overspeed condition has occurred. Attempt to restart the engine by pressing the 'Crank A' or 'Crank B' button. The engine should not restart until a reset has occurred.
Press the RESET / STOP button to reset the FPDP and clear the engine overspeed alarm on the pump controller.		

Alternate Method (engine off)

TEST	Begin with the engine OFF at the pump controller and the FPDP in Auto mode. Press MENU> OVERSPEED TEST > Run.		
	A dialog box will appear alerting the user that the engine will ramp to an overspeed condition. Since the engine is not running, an overspeed condition will NOT occur. Select Yes to run the test.		
	After the countdown timer expires, an engine overspeed fault will be simulated by the FPDP. "ENGINE OVERSPEED" will flash on the screen.	VERIFY	When the timer expires, "ENGINE OVERSPEED" written in red will flash at the top of the FPDP screen until a reset occurs. The pump controller alarm indicates that an overspeed condition has occurred.
	The engine will not restart until the overspeed condition has been cleared. Attempt to restart the engine by pressing the 'Crank A' or 'Crank B' button.		The FPDP does not allow the engine to restart until a reset has occurred.
	Press the RESET / STOP button to reset the FPDP and clear the engine overspeed alarm on the pump controller.		

3.15.11 TB-2 - Crank Termination Switch

The Fail to Start alarm is generated by the fire pump controller if it does not receive a crank terminate B+ signal from TB-2 of the FPDP

IMPORTANT: *To prevent damage to the starter, **disconnect the starter prior to performing the overcrank test** by removing power from the starter(s) B+ terminal(s). Ensure that the disconnected terminal is safely covered during the testing. Reconnect the starter at the conclusion of the overcrank testing.*

TEST	With the pump controller and the FPDP in Auto mode, simulate a pressure drop to energize the FPDP TB-1 and engage the crank sequence to start the engine.		
	The pump controller will repeat a 15-second crank and a 15-second rest 6 times by sending B+ voltage to either TB9 - Main Battery Contactor One Coil or Battery Relay One Coil and TB10 - Main Battery Contactor Two Coil or Battery Relay Two Coil in the FPDP.	VERIFY	The pump controller alarm indicates that an fail to start condition has occurred.

3.15.12 Troubleshooting a Terminal Block Connection:

ECM autoswitching must be enabled for NFPA 20 compliance To verify that autoswitching is enabled.:

TEST	Press MENU > ENGINE SETUP > AUTOSWITCH		
	Ensure that Autoswitch Enable is ON (soft button is green).	VERIFY	ECM autoswitching is enabled.

If the pump controller does not register a fault when it has been activated by the FPDP by the methods described in the above testing, the first step should be to check that the FPDP is activating the alarm which - for all cases other than **TB-3 – Overspeed Switch** and **TB2-Crank Termination Switch** - is a switch to ground. (**TB-3 - Overspeed Switch** and **TB-2-Crank Termination Switch** are switches to **B+** (Battery Positive).) To check the connection between the two devices, use a multimeter to manually verify the terminal block alarm signals in the FPDP are activating.

If the previous test is successful, and the pump controller does not register an alarm, a wiring issue exists between the FPDP and the pump controller.

This page is intentionally left blank.

4 - Operation

4.1 Introduction

This section outlines general operating information for starting and stopping the fire pump drive engine, as well as instructions for navigating the menu screens of the Fire Pump Digital Panel (FPDP). This manual is provided for your equipment and should be considered a part of that equipment. All personnel responsible for the operation and maintenance of the equipment should read and thoroughly understand this manual.

▲ WARNING

Before preparing the equipment for normal service, complete all safety checks, remove all tools and foreign objects from the equipment, ensure all guards are in place and securely fastened, and alert area personnel that the equipment will be starting.

4.2 Starting and stopping procedures

By default, the fire pump drive engine will turn on automatically when low system water pressure is sensed by the pump controller. The engine will continue to operate as long as TB-1 is active. When the TB-1 signal is terminated by the fire pump controller, the engine will stop or enter a cool down procedure by lowering the engine speed.

For testing purposes, the fire pump drive engine can be turned on and off locally using the buttons on the FPDP (see the FPDP Description section). If the engine fails to start automatically in the event of a fire emergency, follow the Emergency Starting/Stopping Procedure outlined in Section [4.2.2](#).

4.2.1 Local starting/stopping procedure

To start the engine locally from the FPDP:

1. Press the AUTO/MAN selector switch on the FPDP to place the engine in MANUAL mode.
2. Press the CRANK BATT A and/or CRANK BATT B button to crank the engine.

The engine may be stopped locally by pressing the RESET/STOP switch on the FPDP or by holding down the red Engine STOP button on the left side of the FPDP.

NOTE: *Upon release of the Engine STOP Button, the fire pump drive engine will attempt to restart, if there is still a “pump on demand” signal present from the fire pump controller. The engine must also be stopped at the fire pump controller.*

4.2.2 Emergency starting procedure

The engine will start automatically in the event of a fire emergency. However, if it fails to start automatically, the engine can be started locally. The following procedure outlines an emergency manual mode electrical start:

1. As shown in [Figure 4-1](#), open the fuel bypass valve in the fuel bypass loop.

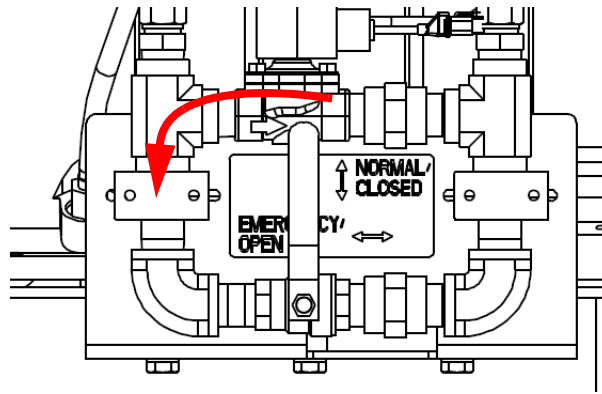

Figure 4-1 Fuel Bypass Valve

2. As shown in [Figure 4-2](#), open the water bypass valves (2) in the cooling water supply piping or the emergency cooling supply.

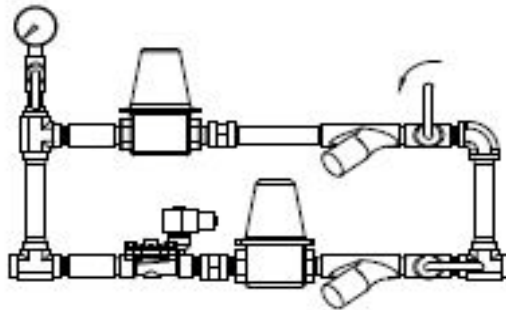

Figure 4-2 Water Bypass Valves

3. Press the AUTO/MAN selector switch on the FPDP to place the engine in MANUAL mode.

- As shown in [Figure 4-3](#), open the FPDP panel door and slide the key switch override to the “RIGHT” position. Verify that LED 49 - KEY FB (key feedback) switch is lit.

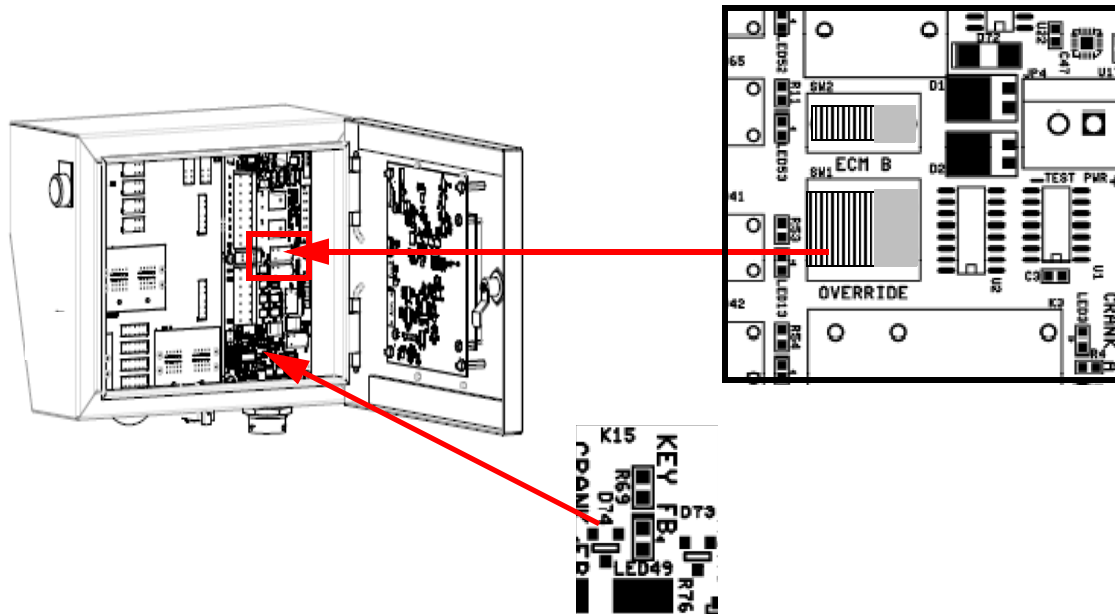

Figure 4-3 FPDP override switch

CAUTION

To prevent damage to the starter, do not engage the starting motor more than fifteen seconds. Wait fifteen seconds between each attempt to start, up to six attempts.

5. As shown in [Figure 4-4](#), press downward on either the Battery A or Battery B contactor lever to start the engine. If crank contactor lever A does not engage the starter, repeat using crank contactor lever B. If the battery charge is low, press downward on both battery contactor levers at the same time. Release the contactor lever immediately after the engine starts.

IMPORTANT: *If the engine does not start after three attempts, check the fuel supply system. Absence of blue or white exhaust smoke during cranking indicates that no fuel is being delivered.*

6. Check that the engine starts and operates at the rated speed.

IMPORTANT: *Engine oil pressure must be indicated on the gauge within fifteen seconds after starting.*

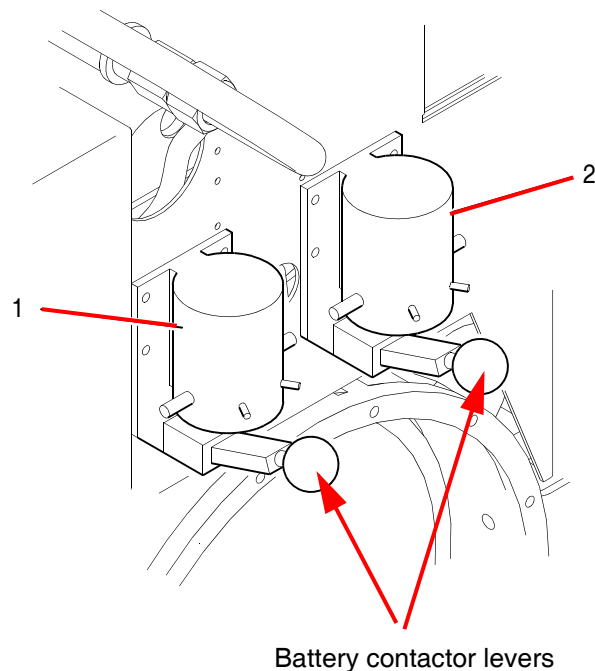

1. Battery A starter contactor
2. Battery B starter contactor

Figure 4-4 Manual starter contactors

The engine may be stopped locally by pressing the RESET/STOP button on the FPDP or by holding down the red ENGINE STOP button on the left side of the FPDP.

IMPORTANT: *Upon release of the Engine **STOP** Button, the fire pump drive engine will attempt to restart, if there is still a “pump on demand” signal present at the FPDP. The engine must also be stopped at the fire pump controller.*

4.3 Fire Pump Digital Panel (FPDP) screens and adjustments in automatic mode

The FPDP consists of an LCD touchpad that displays the fire pump drive engine tachometer, coolant temperature, oil pressure, Battery A voltage, Battery B voltage and hour meter, as well as includes three soft keys:

- **SCREEN** soft key
- **MENU** soft key
- **IDLE** soft key (electronic engines in **MAN** mode, only)



Figure 4-5 FPDP User Interface screen (electronic engine)

NOTE: *Electronic engines display tachometer, engine temperature and oil pressure values from J1939. Mechanical engines display parameters via sensors added by Cummins.*

NOTE: *When the key switch is not on, the coolant temperature defaults to “0 °F” (or “0 °C”) and the oil pressure defaults to “0 PSI” (or “0 kPa”).*

The FPDP LCD will go into **SLEEP MODE** after fifteen minutes of inactivity by the user. The FPDP LCD will resume normal display features when the user presses a hard button or touches the LCD screen.

4.3.1 The SCREEN soft key

The **SCREEN** soft key, on the bottom right of the LCD, deactivates and activates an overlay box which lies atop the tachometer signal (the engine speed is still digitally displayed). The overlay is used to:

- Automatically - Warn the operator of ECM and/or DPEM faults, when applicable (see Section 4.3.2.6 [FAULT CODES screen](#)); and/or
- Operator-selected - Display additional analog values not required by NFPA 20.

The overlay background color will display in gray, unless there is an active fault present. Fault overlays will display in the color of the most severe fault. To deactivate the Fault overlay, press the **SCREEN** soft key to make the overlay disappear from the LCD.

As shown below, the Analog Values overlay background color displays in gray.

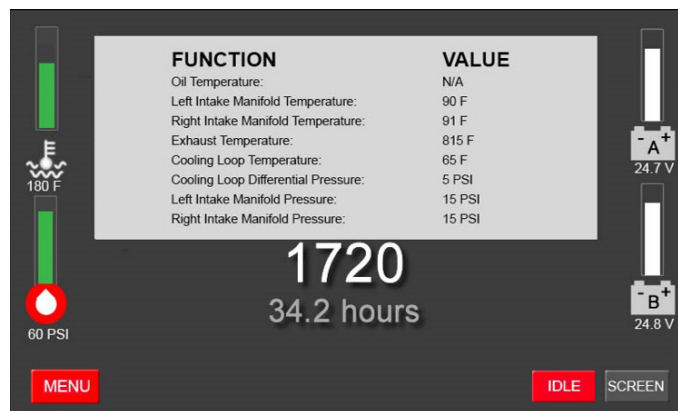

Figure 4-6 Analog Values overlay (electronic engine)

Additional values that may be displayed include:

- Exhaust temperature (when a thermocouple is installed and terminated to the Power Board).
- Cooling loop raw water temperature and strainer status on FM-approved and UL-listed fire pump drivers. The Analog Values overlay can assist in troubleshooting the cooling loop by identifying issues with the pressure sensors.
- J1939 parameters.

NOTE: The Oil Temperature value (from J1939) will only be shown on CFP11E and CFP15E.

NOTE: The Intake Manifold Pressure (from J1939) will be showing 0 PSI at no load.

NOTE: A thermocouple must be purchased and installed from Cummins in order for exhaust temperature values to display. If a thermocouple is not connected to the Power Board or the thermocouple input temperature is less than 200 °F, the Exhaust Temperature will display 0 °F.

To deactivate the Analog Values overlay, press the **SCREEN** soft key to make the overlay disappear from the LCD.

4.3.2 The MENU soft key - Settings Menu

If the operator presses the **MENU** soft key from the FPDP User Interface screen, the Settings Menu screen appears as shown below.

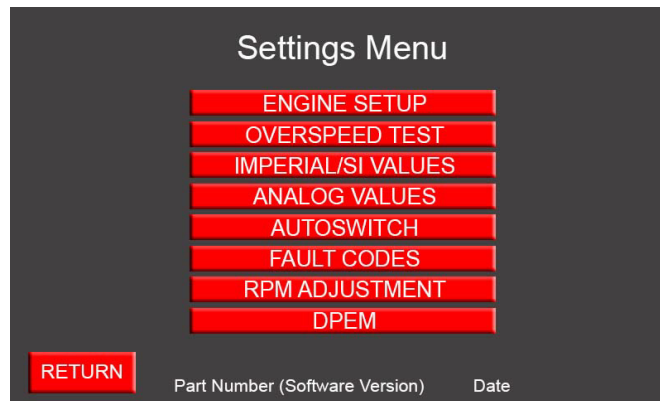

Figure 4-7 Settings Menu screen (electronic engine)

The Settings Menu provides options for further operator input and monitoring of fire pump drive engine parameters. Press the corresponding soft key to access a sub-menu.

4.3.2.1 ENGINE SETUP screen

The fire pump drive engine was preconfigured with custom options (if applicable) at the factory prior to shipping to the customer. The System Options screen provides a view of the custom configuration that has been set up for your fire pump drive engine. The Cummins Service Department must be notified if any of these parameters are adjusted in the field.

1. Starting at the User Interface screen, press the **MENU** soft key.
2. As shown below, press the soft number keys to enter password "806" in the Engine Setup Login screen.
3. Then press **SUBMIT** to access the Engine Setup screen.

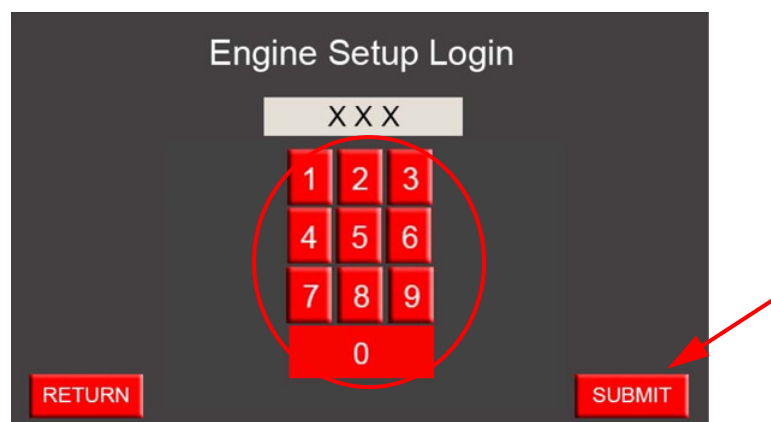

Figure 4-8 Typical Engine Setup Login screen

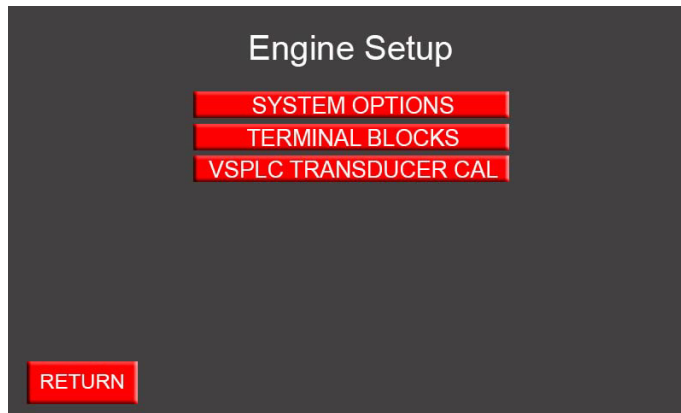

Figure 4-9 Engine Setup screen (electronic engine)

Engine Setup screen - SYSTEM OPTIONS

The System Options sub-menu displays the custom configurations of the fire pump drive engine. When active, the soft buttons turn green in color and display “ON”. Conversely, the soft button will turn red in color and display “OFF”, if the feature is disabled. To change a numeric data field, tap the data field to access the popup keyboard and enter different data.

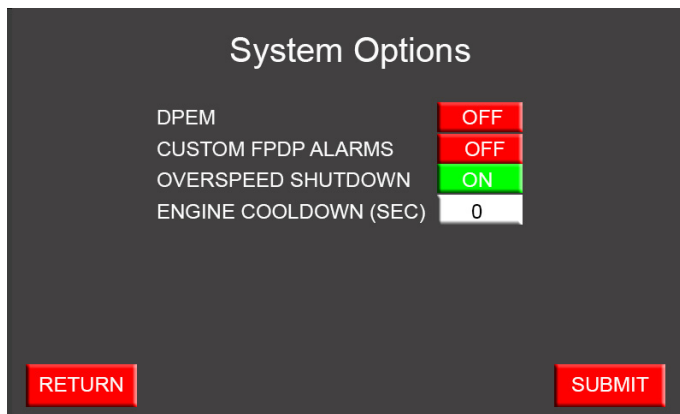

Figure 4-10 System Options screen (electronic engine)

The custom options of the System Options sub-menu include:

DPEM – When active, the FPDP initiates communications with the Digital Panel Expansion Module (DPEM).

CUSTOM FPDP ALARMS – When active, the custom FPDP Terminal Block assignments will be activated.

OVERSPEED SHUTDOWN – When active, the FPDP shuts the engine fueling off when the engine speed reaches or exceeds 115% of the configured rated speed.

ENGINE COOLDOWN (SEC) (on electronic engines only) - When active, the operator shall denote a specific amount of seconds to idle the fire pump drive engine. When the engine cool down is disabled, the seconds shall be set to "0" (see [4.5 Engine/turbocharger cool down](#)).

Press either **RETURN** or **SUBMIT** to return to the Engine Setup menu.

Engine Setup screen - TERMINAL BLOCK TEST

The TERMINAL BLOCKS sub-menu provides a convenient means of checking the signal integrity between the fire pump controller and the terminal block interface inside the FPDP.

As shown in [Figure 4-11](#), any of the signals on the terminal block interface can be manually activated by pressing the respective red soft key. When the button turns green, the signal is active.

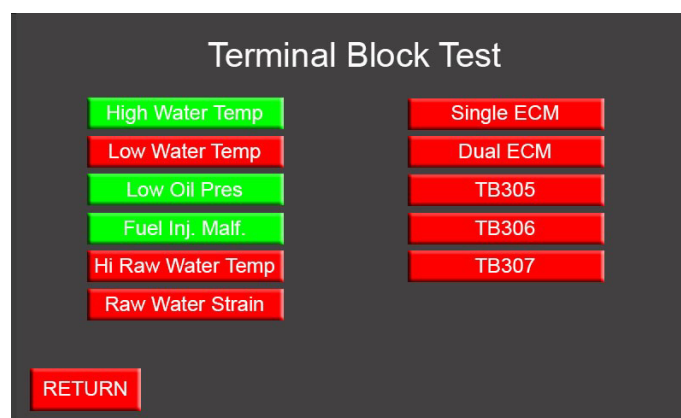

Figure 4-11 Typical Terminal Block Test screen

To perform a Terminal Block Test:

1. Starting at the User Interface screen, press the **MENU** soft key;
2. Press the **ENGINE SETUP** soft key from the Settings menu;
3. As shown in [Figure 4-8](#), press the soft number keys to enter password "806" in the Engine Setup Login screen.
4. Press the **TERMINAL BLOCKS** soft key from the Engine Setup menu;
5. Press the soft key corresponding to the terminal block requiring verification;

NOTE: *If the selected terminal block soft key turns green, but the pump controller alarm does not activate, troubleshoot the terminal block connection for a B+ or ground signal (see the [Section FPDP Signal and Control Connections](#) or contact your local Cummins Sales and Service representative).*

NOTE: *For electronic engines, the Fuel Inj. Malf. (fuel injection malfunction) can only momentarily be set.*

6. To exit the Terminal Block Test menu, press the **RETURN** soft key to return to the Engine Setup menu.

NOTE: *Oil pressure and coolant temperature alarms will not latch upon backing out of the menu, but instead will be driven directly from datalink values.*

Engine Setup screen -VSPLC TRANSDUCER CAL (electronic engines with VSPLC capability, only) (optional)

NOTE: The VSPLC TRANSDUCER CAL screen *only* applies to electronic VSPLC fire pump drive engines. The settings in this menu are meaningless unless VSPLC is enabled. This section is not applicable to mechanical engines.

To account for a system pressure differential, the operator may enter a pressure offset. This same pressure offset is used throughout the entire incoming pressure range. To access the VSPLC Transducer Configuration screen:

1. Starting at the User Interface screen, press the **MENU** soft key.
2. Press the **ENGINE SETUP** soft key from the Settings menu.
3. As shown in [Figure 4-8](#), press the soft number keys to enter password “806” in the Engine Setup Login screen.
4. Press the **VSPLC TRANSDUCER CAL** soft key from the Engine Setup menu.
5. As shown in [Figure 4-12](#), press the VSPLC Offset (PSI) data field to activate the popup keyboard and enter the desired pressure offset.

NOTE: The software limits the pressure offset to +/- 10 PSI with a resolution of 0.1 PSI.

6. Then press **SUBMIT**.

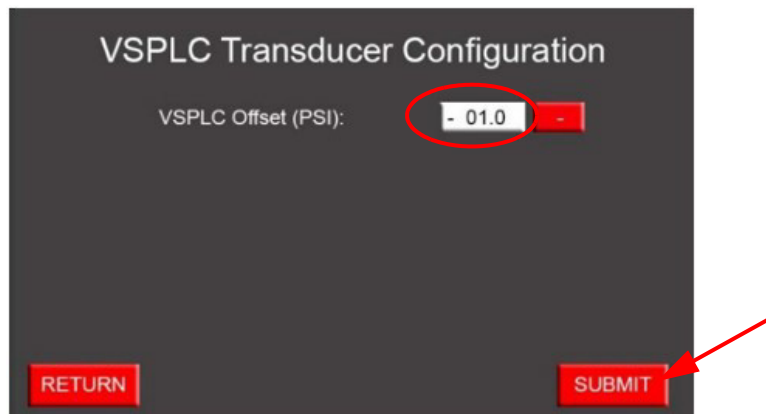

Figure 4-12 VSPLC Transducer Configuration

7. Press **RETURN** to return to the Engine Setup menu.

4.3.2.2 OVERSPEED TEST screen

The Overspeed Test screen shown below allows the operator to simulate an overspeed shutdown for all engine models. Refer to “Start-up Validation” in the Installation Section of this manual for detailed instructions on how to simulate an overspeed shutdown.

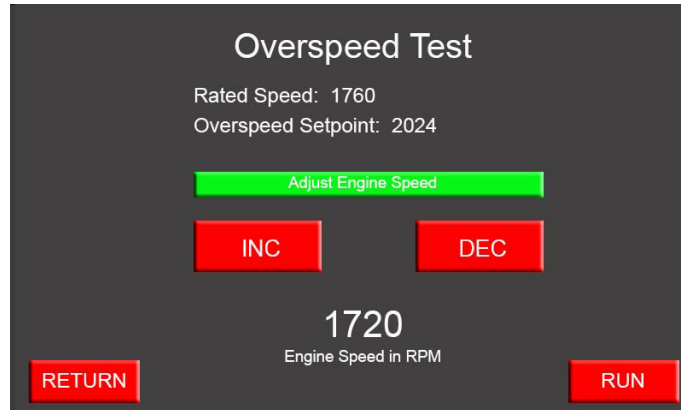

Figure 4-13 Overspeed Test screen

4.3.2.3 IMPERIAL/SI VALUES screen

The Imperial/SI Values screen, shown in [Figure 4-14](#), allows the operator to select Imperial or *Système Internationale* (SI) (also known as metric) units of measurement. The default units of measure are Imperial units of degrees in Fahrenheit and pounds per square inch (PSI), but the user may elect degrees in Celsius or kilo Pascal (kPa).

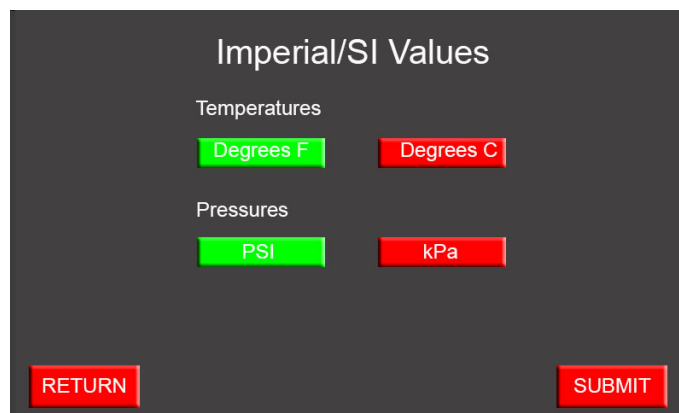

Figure 4-14 Typical Parameter Units screen

To change the displayed units of measurement:

1. Starting at the User Interface screen (Main Menu), press the **MENU** soft key.
2. Press the **IMPERIAL/SI VALUES** soft key from the Settings Menu.
3. Press the soft key for the desired unit of measure.

4. Press the **SUBMIT** soft key.
5. To exit the Imperial/SI Values menu, press the **RETURN** soft key.

4.3.2.4 ANALOG VALUES screen

To view the information about the fire pump drive engine in digital format:

1. Starting at the User Interface screen (Main Menu), press the **MENU** soft key.
2. Press the **ANALOG VALUES** soft key from the Settings Menu.
3. To exit the Analog Values screen (shown below), press the **RETURN** soft key.

NOTE: *The display choice of Imperial or SI values is made using the Imperial/SI Values screen.*

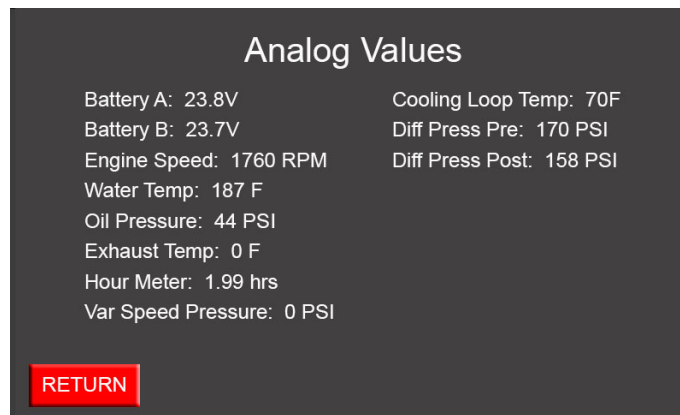

Figure 4-15 Sample Analog Values screen

4.3.2.5 AUTOSWITCH screen

NOTE: *The AUTOSWITCH screen is on electronic engines, only. This section is not applicable to mechanical engines.*

The National Fire Protection Association (NFPA) 20 Standard, as well as Underwriters Laboratories (UL) and Factory Mutual (FM) Standards, requires redundancy for fire safety systems. If the fuel system is electronically-controlled, switching of ECMs must be controlled automatically. Cummins refers to this process as "ECM Autoswitching." When the FPDP switches ECMs automatically, the fault code responsible for the last switch can be found on the Autoswitch screen. The FPDP will activate the ECM keyswitch for fifteen seconds every thirty minutes to validate communications with the ECM.

IMPORTANT: *In order to maintain NFPA 20 compliance, autoswitching must be **enabled (ON)**.*

As shown in [Figure 4-16](#), the Autoswitch Settings screen allows the operator to disable or enable this autoswitch capability.

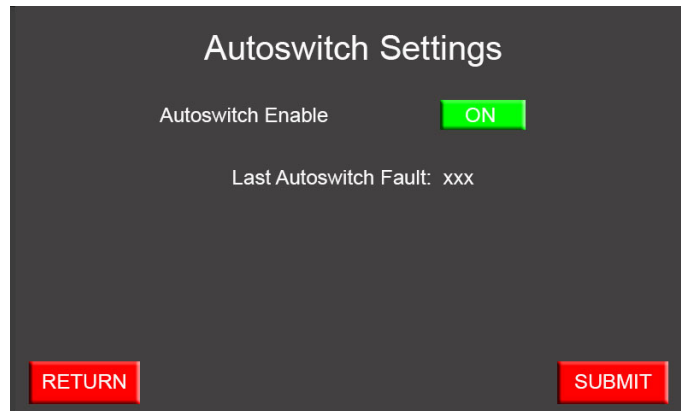

Figure 4-16 Typical Autoswitch Settings screen

To change the autoswitch setting:

1. Starting at the User Interface screen, press the **MENU** soft key;
2. Press the **ENGINE SETUP** soft key from the Settings menu;
3. As shown in [Figure 4-8](#), press the soft number keys to enter password “806” in the Engine Setup Login screen.
4. Press the **AUTOSWITCH** soft key from the Settings Menu.
5. Press the **ON/OFF** soft key - the soft key displayed (in green) indicates which mode has been selected.
6. Press the **SUBMIT** soft key.
7. To exit the Autoswitch Settings screen, press the **RETURN** soft key.

4.3.2.6 FAULT CODES screen

NOTE: *The FAULT CODES screen is on electronic engines, only. This section is not applicable to mechanical engines.*

As shown in the Description Section, fault codes diagnosed by the ECM are displayed in a yellow or red overlay box which lies atop the tachometer signal (the engine speed is still digitally displayed) to alert the operator to service the engine as soon as possible. Only the first seven active ECM faults will be displayed in the overlay.

As shown in [Figure 4-17](#), the Fault Codes screen displays the full list of active faults. To view the information about the fire pump drive engine active faults:

1. Starting at the User Interface screen (Main Menu), press the **MENU** soft key.
2. Press the **FAULT CODES** soft key from the Settings Menu.
3. To exit the **FAULT CODES** menu, press the **RETURN** soft key.

For more information about fault codes and their meanings, see the Fault Code Section of this manual or contact your local Cummins Distributor.

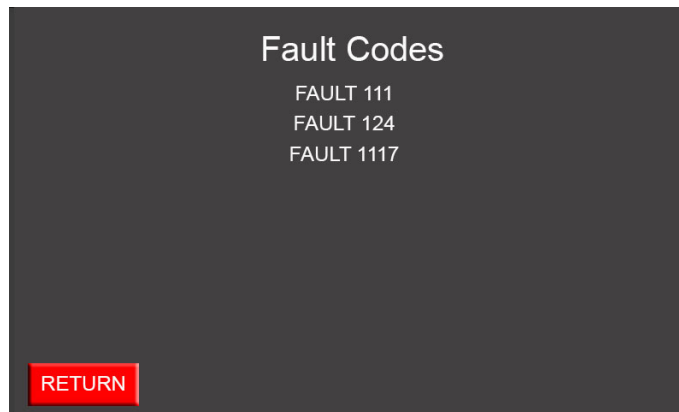

Figure 4-17 Sample Fault Codes screen

4.3.2.7 RPM ADJUSTMENT screen

NOTE: *The RPM ADJUSTMENT screen is on electronic engines, only. This section is not applicable to mechanical engines.*

As shown in [Figure 4-18](#), the RPM Adjustment screen allows the operator to make on-site adjustments to **FIXED SPEED** fire pump drive engines. Each press of the INC soft key or the DEC soft key will increase or decrease the engine speed setpoint by 10 RPM (not to exceed +/-50 RPM) for electronic engines.

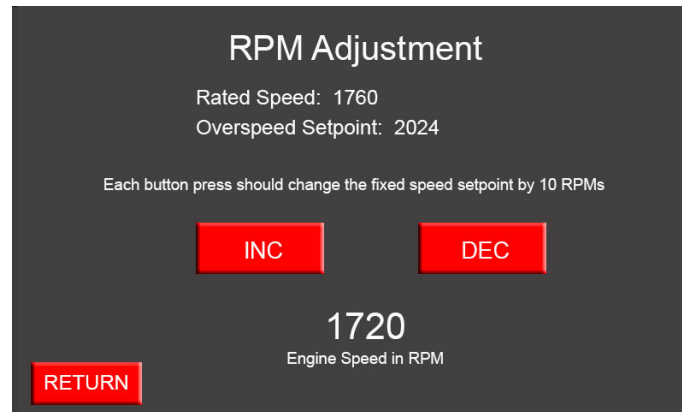

Figure 4-18 Typical RPM Adjustment screen

The engine operating speed was factory set during manufacturing and test procedures. If the speed does not match the engine RPM shown on the factory setting plate, follow these steps to adjust the speed setting:

1. Starting at the User Interface screen (Main Menu), press the **ECM A** Selector switch.
2. Press the **MENU** soft key.
3. Press the **RPM ADJUSTMENT** soft key from the Settings Menu.
4. Press either the **INC** soft key or the **DEC** soft key to change the ECM RPM setpoint.
5. Press the **RETURN** soft key.
6. Press the **RESET/STOP** switch on the FPDP and wait for thirty seconds.
7. Repeat Steps 1 through 5 for **ECM B**.

NOTE: *The speed setpoint adjustments must be made on each ECM to experience the same system level of performance on the alternate ECM.*

IMPORTANT: *Never switch from ECM A to ECM B while the engine is running.*

4.3.2.8 DPEM (optional)

As shown in [Figure 4-19](#), the DPEM screen displays the function name, status, alarm setpoint, and relay associated with the alarm (if applicable) of any custom inputs that are configured on the fire pump drive engine. When an analog input parameter crosses the alarm setpoint or a switched input is active, all information associated with that parameter will turn red in color. To access the DPEM screen:

1. Starting at the User Interface screen (Main Menu), press the **MENU** soft key.
2. Press the DPEM soft key from the Settings Menu.
3. To exit the DPEM screen, press the **RETURN** soft key.

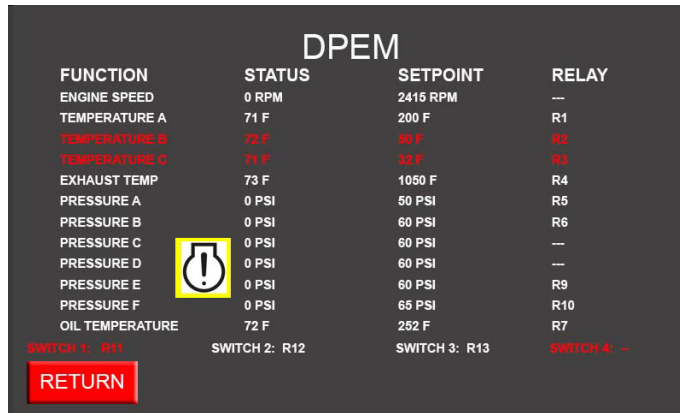

Figure 4-19 Sample DPEM screen

If communications between the FPDP and DPEM are compromised, a “DPEM COMMS ERROR” message will appear at the top of the screen.

4.4 FPDP screens and adjustments in manual mode - IDLE soft key

NOTE: The **IDLE** soft key shown in [Figure 4-20](#) displays in red while the engine idle command is inactive. The **IDLE** soft key will display in green when the engine idle command is active.



Figure 4-20 IDLE soft key

With the FPDP in manual mode and using the **IDLE** soft key, the FPDP can now command electronic engines to idle. The operator can choose to idle the fire pump drive engine to warm up the engine for weekly testing and/or to evaluate water leaks during commissioning. To manually place the fire pump drive engine in idle:

1. Select **MAN** on the **AUTO/MAN** mode switch on the FPDP to place the fire pump drive engine in manual mode.
2. Press the **IDLE** soft key on the screen.

NOTE: Engaging the **IDLE** soft key will turn the **IDLE** soft key display from red to green, engaging the engine idle command.

3. Press the **BATT A** or the **BATT B** Momentary Start switch to start the engine.
4. To disengage manual engine idle, press the **IDLE** soft key on the screen. The **IDLE** soft key will return to red in color.

The engine will ramp to rated speed. The engine will also ramp to rated speed (for fixed speed applications) or enter a closed loop VSPLC mode, if enabled, when TB-1 becomes active while the engine is idling.

4.5 Engine/turbocharger cool down

The FPDP has the ability to idle an electronic engine for up to three minutes when a shutdown has been commanded from the fire pump controller. The cool down feature promotes engine turbocharger longevity. During engine cool down, the FPDP will display an “Engine Cooldown Active:” message (shown in [Figure 4-21](#)).

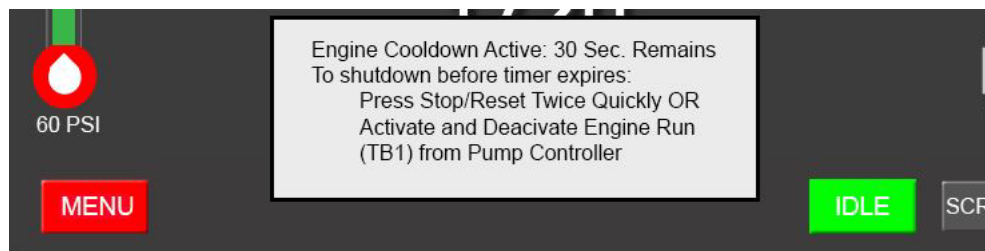

Figure 4-21 Engine/turbocharger cool down

During engine cool down, the fire pump drive engine may shutdown automatically - prior to the timer expiring - to protect the engine. The operator also has the option to shut down the engine manually from the fire pump controller or the FPDP during cool down, if necessary.

IMPORTANT: All fire pump drive engines are shipped from the factory with the cool down feature disabled. This feature must be manually enabled by the customer. Prior to enabling the cool down feature, ensure all operators are trained on the operation of this engine cool down feature.

4.5.1 Automatic shutdown - cool down timer

The fire pump drive engine will automatically shutdown when the Engine Cooldown timer expires.

4.5.2 Automatic shutdown - engine protection

The FPDP will automatically shut the engine off and during engine cool down if:

- Low oil pressure is sensed;
- High coolant temperature is sensed; and/or
- Communications with the ECM are lost.

4.5.3 Manual shutdown - from the fire pump controller

During cool down, the fire pump drive engine can be shut down manually from the fire pump controller by:

1. Turning the fire pump controller switch to **OFF** (deactivating TB-1). NOTE: *The FPDP will keep the fire pump drive engine running to idle until the timer expires; AND*
2. Turning the fire pump controller from **OFF** to **MAN** (manual) and back to **OFF** (reactivating and deactivating TB-1). The fire pump drive engine will shut down immediately.

4.5.4 Manual shutdown - from the FPDP

The engine can also be shutdown manually by pressing the **RESET/STOP** switch on the FPDP two times in succession.

5 - Maintenance

5.1 Introduction

Before performing maintenance procedures, read and understand [1 - Safety](#) of this manual. Improper performance or lack of critical information could result in personal injury or equipment damage.

Cummins encourages our customers to perform maintenance and repairs whenever necessary. However, servicing complex components within the normal warranty period may void the Cummins warranty and any specified warranty extended by the manufacturer of Original Equipment Manufacturer (OEM) products. See the warranty information at the beginning of this manual.

Maintenance procedures should be performed by skilled technicians who are familiar with the equipment, local regulations, and service procedures for fire pump drive engine and pump systems. Improper maintenance can damage the engine or the fire pump drive engine, or cause severe personal injury.

The National Fire Protection Association (NFPA) 25 Standard outlines the maintenance tests to be performed to validate automatic and manual operational requirements for field acceptance testing.

Cummins recommends that the engine be maintained according to the Cummins Operation and Maintenance manual for that engine family.

NOTE: *If your engine is equipped with a component or accessory not manufactured by Cummins, refer to the component manufacturer's vendor supplied literature for specific maintenance recommendations.*

5.2 Engine operation reports

The engine must always be maintained in top mechanical condition. Proper maintenance of the fire pump drive engine requires documenting regular running reports to include the following:

- Low engine oil pressure.
- Engine surge.
- Erratic operation or frequent shutdowns.
- Any warning lamps flashing or staying illuminated.
- Abnormal coolant or oil temperature.
- Unusual engine noise or vibration.
- Excessive smoke.
- Excessive use of coolant, fuel, or engine oil.
- Any fluid leaks.
- Loose, worn, or damaged parts.

Maintenance

The weekly running report also helps to make provisions for more extensive maintenance, as the reports indicate the necessity.

The Fault Codes displayed on the Fire Pump Digital Panel assist in recording operation irregularities. See [6 - Troubleshooting](#) of the model-specific English manual for a listing of Fault Codes.

5.3 Weekly maintenance

When the engine is running, be alert for mechanical problems that could create unsafe or hazardous conditions.

5.3.1 General

Each week, a general walk-around inspection should include the following areas:

1. Check fluid levels before starting the engine. Check oil pressure and coolant temperatures frequently. Most engine problems give an early warning.
2. Look and listen for changes in engine performance, sound, or appearance that will indicate that service or repair is needed. Be alert for misfires, vibration, excessive exhaust smoke, loss of power, or increases in oil or fuel consumption.
3. Check the engine appearance for excessive heat, wiring short circuits, excessive end-play, vibrations, excessive wear, excessive abrasion, damaged electrical wiring, or loose electrical wiring.
4. Check the engine for odors of diesel fuel, burning rubber, electrical system failure, exhaust fumes, or smoke.

WARNING

Engine fuel is highly flammable and represents an extreme hazard for fire or explosion when exposed to electrical sparks or open flame. Clean up spilled fuel immediately. Keep sources of electrical spark or open flame away from a fuel source.

5.3.2 Air cleaner filter and piping

On a weekly basis, perform the following inspections:

1. Visually inspect the air intake filter and piping daily for blockage, damage to piping, loose clamps, or punctures that can allow debris to enter the engine. If there is a blockage, the service indicator will be activated. Refer to [Figure 2-2](#).

NOTE: Turbocharged engines must be operated at rated revolutions per minute (RPM) and full load to check maximum intake air restriction.

NOTE: Cummins recommends using an air cleaner filter element as listed on the [engine data sheet](#).

CAUTION

Never operate the engine without an air cleaner. Intake air must be filtered to prevent dirt and debris from entering the engine and causing premature wear. Dirt or foreign objects could cause engine damage.

- a. If the red indicator flag is at the raised position in the window, clean or replace the air filter per the manufacturer's recommendation as required. Do not remove the felt washer from the indicator. The felt washer absorbs moisture.
- b. After the air cleaner has been serviced, push the flag in to reset the service indicator.

IMPORTANT: See the [engine data sheet](#) for maximum intake air restriction.

2. Check for corrosion under the clamps and hoses of the intake system piping. Corrosion can allow corrosive products and dirt to enter the intake system. Disassemble and clean as required.
3. Replace any damaged air filter or hoses and tighten loose clamps, as necessary, to prevent the air system from leaking. Torque the hose clamps to the recommended torque value. Refer to the [torque tables](#).

5.3.3 Cooling system

CAUTION

Do not remove a coolant pressure/fill cap from a hot engine. Shut down the engine and wait until the coolant temperature is below 50 °C (120 °F) before removing the pressure cap. Heated coolant spray or steam can cause severe personal injury.

On a weekly basis, perform the following inspections on the cooling system:

1. Inspect the cooling water piping, coolant heat exchanger tanks, charge air cooling system (if applicable), engine coolant hoses, and hose clamps for loose fittings, leaks, damage, and corrosion.
 - a. Tighten the hose clamps, as necessary.
 - b. Check for cracks, holes, or other damage. Repair or replace as necessary.

CAUTION

Never use a sealing additive to stop leaks in the cooling system. This can result in cooling system plugging and inadequate coolant flow, causing the engine to overheat.

2. With the coolant expansion tank at ambient temperature, press down, unscrew, and remove the pressure cap as shown in [Figure 2-2](#).
 - a. Ensure that the coolant level is visible by checking the coolant level sight gauge.
 - b. Add coolant, as required. DO NOT OVERFILL!

NOTE: Supplemental engine coolant should be a mixture of 50% ethylene glycol antifreeze and 50% water to avoid engine damage.

3. Check the antifreeze concentration at least six times a year or whenever coolant is added to the cooling system by using a refractometer.
4. Drain a small amount of coolant from the return line petcock and inspect the coolant for excessive rust or particulate matter. Change the coolant more frequently if particles are present.

CAUTION

Do not mix coolant brands or chemical solutions, as this could damage the cooling system. Keep a record of the coolant concentration and manufacturer with the engine maintenance records.

5. Check for soft, overly-pliant hoses, oxidation, and loose hose clamps. Torque the hose clamps to the recommended torque value. Refer to the [torque tables](#). Replace damaged hoses and clamps as required.
6. Check the coolant heat exchanger tanks for leaks, damage, and dirt buildup. Clean and repair as required.

5.3.4 Engine oil system

WARNING

Perform the specific checks in this section only after the engine is fully stopped. Unless tests require engine operation, disconnect the battery leads from the batteries (negative terminal first). Contact with exposed or moving components can cause severe personal injury.

Inspect the engine oil system on a weekly basis following these steps:

1. For accurate dipstick readings, shut off the engine and wait approximately ten minutes to allow the oil in the upper portions of the engine to drain back into the crankcase.
2. As shown in [Figure 5-1](#), check the oil level at the engine dipstick.
 - If the oil level is greater than the high mark (H), drain the excess oil and recheck the level.
 - If the oil level is consistently below normal after a fill, check for leaks, loose or damaged gaskets, or oil in the coolant system. If the oil level is below the low mark (L), add the equivalent type oil.

NOTE: Cummins recommends using Premium Blue[®] 15W-40 Multi-viscosity Lubricating Oil or equivalent.

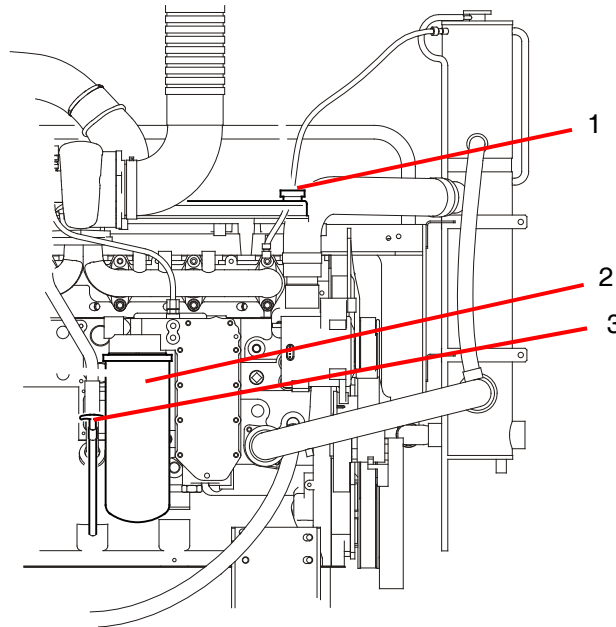

1. Engine oil fill port
2. Engine oil filter
3. Engine oil dipstick

Figure 5-1 Oil level dipstick (typical)

5.3.5 Fuel system



Engine fuel is highly flammable and represents an extreme hazard for fire or explosion when exposed to electrical sparks or open flame. Clean up spilled fuel immediately. Keep sources of electrical spark or open flame away from a fuel source.

To inspect the fuel system:

1. Shut off the engine.
2. Inspect the fuel supply line, return line, filter and fittings for cracks or abrasions.
 - a. Ensure the lines are not rubbing against anything that could damage the fuel system hoses. Repair any leaks or alter line routing to eliminate wear immediately.
 - b. Relieve fuel line pressure by carefully loosening the fuel inlet line.

NOTE: Refer to the [engine data sheet](#) for Cummins recommended replacement components.

5.3.6 Engine exhaust system

With the engine operating, inspect the entire exhaust system: exhaust manifold, exhaust flex, muffler, and piping.

Check for leaks at all connections, welds, gaskets, and joints. Make sure that the exhaust pipes are not heating surrounding areas excessively. Repair any leaks immediately.

5.3.7 Electrical supply and controls

Check the terminals on the starting batteries for clean and tight connections. Loose or corroded connections create resistance which can hinder starting. Inspect the FPDP harness connections to be sure they are secure.

5.3.8 Crankcase ventilation hose

Inspect the crankcase ventilation hose for wear, damage, sludge, blockage, or dirt buildup (refer to [Figure 2-2](#)). Clean the ventilation hose, if obstructed or blocked. Replace a worn or damaged hose.

5.3.9 Heat exchanger - cooling water strainers

As shown in Figure 5-2, the (two) cooling water strainers should be cleaned weekly to remove sediment.

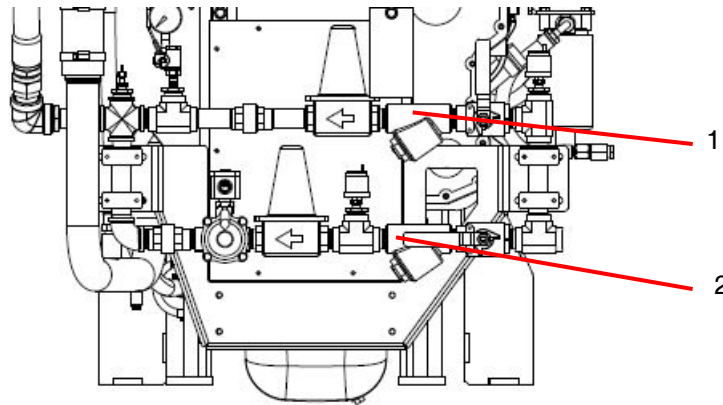

1. Bypass raw water strainer
2. Normal raw water strainer

Figure 5-2 Cooling water strainer (typical)

To clean the normal line strainer, ensure that the normal line valves are closed and the bypass line valves are open.

To clean the bypass line strainer, ensure that the bypass line valves are closed and the normal line valves are open.

For each cooling water strainer:

1. Remove the plug.
2. Inspect and remove any debris.
3. Install the strainer plugs.
4. When finished, open the normal line valves and close the bypass line valves for normal operation.

5.3.10 Batteries

CAUTION

Batteries can emit explosive gases during charging. To reduce the possibility of personal injury, always ventilate the battery compartment before servicing the batteries.

CAUTION

To reduce the possibility of arcing, remove the negative (-) battery cable first and attach the negative (-) battery cable last.

For proper weekly maintenance of the batteries:

1. Keep the batteries clean by wiping them with a damp cloth whenever dirt appears excessive.
2. Use a battery hydrometer to check the specific gravity of the electrolyte in each battery cell. A fully-charged battery will have a specific gravity of 1.260. Replace the battery, if the specific gravity reading is below 1.215.
3. Check the battery wiring and cable connections for loose, corroded, worn, or damaged cables. Check both connectors at the alternator, battery connections, and engine grounding lug (near the starter motor).
 - a. If the battery cables are corroded, remove the battery cable clamps, starting with the negative (-) battery cable.
 - b. Use a fine emery cloth or a wire brush to clean the cable clamps and battery cables. The metal should be shiny.
 - c. Wash the battery terminals with a solution of baking soda and water:

2 oz (1/4 cup) baking soda to 0.94 liter (1 qt) of water
 - d. Be careful to prevent the solution from entering the battery cells, and flush the batteries with clean water when done.
 - e. After cleaning the connections, coat the terminals with a light application of petroleum jelly.
 - f. Reinstall and tighten the cable clamps.

▲ WARNING

Battery electrolyte (sulfuric acid) is highly caustic and can burn clothing and skin, or cause blindness. Wear protective clothing, impervious neoprene gloves, safety goggles, or full-face shield when working with the batteries.

4. Check the electrolyte level in the batteries monthly. If low, fill the battery cells to the bottom of the filler neck with distilled water.
5. Check for continuity between terminals using a digital multimeter or other test equipment. Also check the insulation resistance to ground. Correct any electrical faults.
6. Reinstall the battery cables; attach the negative (-) battery cable last.

5.3.11 Engine test run

Start the engine at least once a week for a minimum of thirty minutes with as much load as possible. Periods of no-load operation should be held to a minimum, because unburned fuel tends to accumulate in the exhaust system. Refer to the operating instructions in [4 - Operation](#).

Check that the engine starts and operates at the recommended fire pump drive engine speed specification and inspect the following:

1. Check that the engine oil pressure is indicated on the gauge within fifteen seconds after starting.
2. Check that the engine has attained a normal running temperature after running the engine for a minimum of thirty minutes.

3. Observe that the engine is operating at the proper operating speed. (If the engine is not operating at the proper speed, see Section [5.3.12 Engine operation checks](#).)
4. Check for unusual engine noise. Listen for any unusual engine noise which can indicate that service is required.
5. Ensure that the oil pressure is greater than 69 kPa (10 psi).
6. Check that the coolant temperature is between 70 °C (158 °F) and 107 °C (225 °F).
7. Check that both battery voltmeters indicate 12 VDC for standard or 24 VDC for optional operating systems.
8. Check that the air filter service indicator has not popped-up, indicating an air filter blockage. Replace the air filter as required.

End the test run by pressing and holding the overspeed RESET/STOP switch until the engine stops.

5.3.12 Engine operation checks

The following service inspections ensure that the engine starts and operates properly under normal conditions.

▲ WARNING

Before equipment operation, ALL guards, covers, and protective devices MUST BE in place and securely fastened. Serious personal injury could result from contact with exposed or moving components.

5.3.12.1 Crank termination setpoint

The speed switch crank termination setpoint is factory-set at 600 RPM and should not be changed from this value.

5.3.12.2 Engine speed adjustment

The electronic engine operating speed was factory set during manufacturing and test procedures. If the speed unintentionally does not match the engine RPM shown on the factory setting plate, refer to [Section 4 - Operation: RPM Adjustment Screen](#).

5.3.13 Engine coolant heater

NOTE: *Perform this inspection procedure twenty-four hours after shutting off the engine.*

The engine coolant heater must maintain an engine coolant temperature of 49 °C (120 °F) or above. The engine block must be warm to the touch (38 °C (100 °F)) in the water jacket areas.

If the heater does not appear to be working correctly, contact a Cummins Authorized Repair Location.

5.4 Annual maintenance

All checks or inspections listed under previous maintenance intervals must also be performed at the time of the annual maintenance, in addition to those listed *only* under the annual maintenance interval.

5.4.1 Electrical components



AVOID SERVICING complex components such as: printed circuit boards, programmable controllers, and ECMs not specifically authorized by Cummins. Contact a Cummins Authorized Repair Location before performing any extensive maintenance.



To reduce the possibility of arcing, remove the negative (-) battery cable first and attach the negative (-) battery cable last.

The electrical components of the fire pump drive engine must be thoroughly inspected on an annual basis. Remove the battery terminal cables, starting with the negative (-) cable first and check the following:

1. Inspect the electrical wiring harness, electrical terminal connections, and electrical plug-ins for secure, clean electrical contacts, worn or damaged insulation, burnt wires, broken wires, and loose connections.
2. Clean and tighten any loose electrical connections. Repair or replace worn, damaged, burnt, or poorly insulated wiring immediately.

IMPORTANT: *Refer to the vendor-supplied literature for recommended maintenance procedures.*

3. Inspect the function of all gauges, voltmeters, switches, and warning lamps on the FPDP. Replace the FPDP if any are not functioning properly.
4. Reinstall the battery cables; attach the negative (-) battery cable last.

5.4.2 Turbocharger mounting nuts

As shown in [Figure 5-3](#), check the turbocharger mounting nuts and torque the mounting nuts to the recommended torque value. Refer to the [torque tables](#).

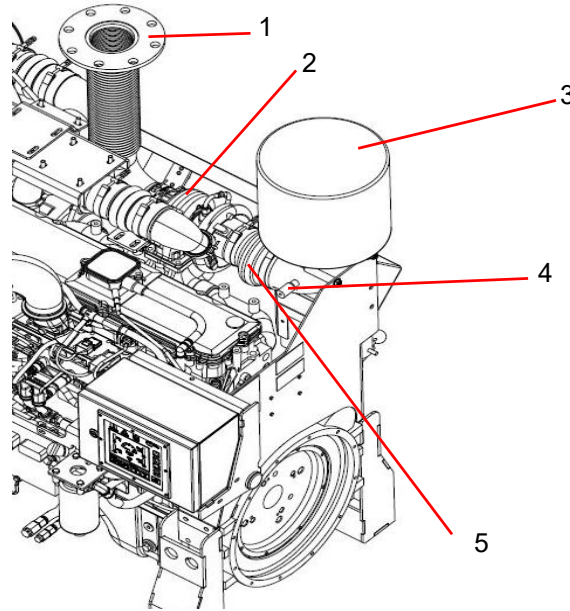

1. Exhaust flex connection
2. Turbocharger
3. Air cleaner assembly (intake)
4. Air cleaner service indicator
5. Air cleaner piping

Figure 5-3 Typical turbocharger

5.4.3 Engine supports

CAUTION

Loose engine mount bolts or damaged brackets can cause engine misalignment or excessive vibration. These conditions can cause engine or pump damage.

Refer to [Figure 2-2](#) and [Figure 2-3](#) for the location of the engine supports and inspect all engine supports for cracks or loose hardware. Check the torque on the engine support mounting capscrews. Torque the engine mounting cap screws to the support bracket. Refer to the [torque tables](#) for recommended torque values.

5.4.4 Fuel pumps and filters

As shown in [Figure 5-4](#), inspect the fuel injection pump mounting nuts (including the support bracket) for loose or damaged hardware. Inspect the fuel line hoses and fuel filters for wear, damage, loose fittings, and leaks. Repair or replace damaged hoses and filters as required.

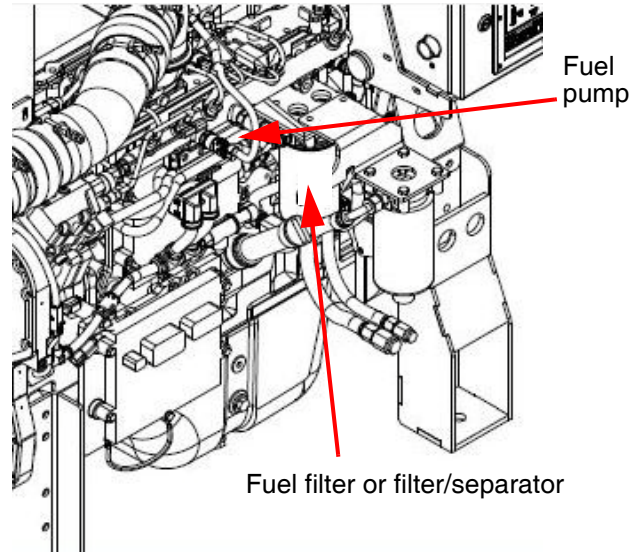

Figure 5-4 Typical fuel pumps and filters

WARNING

Engine fuel is highly flammable and represents an extreme hazard for fire or explosion when exposed to electrical sparks or open flame. Clean up spilled fuel immediately. Keep sources of electrical spark or open flame away from a fuel source.

WARNING

Do not open the fuel filter/water separator drain valve or dismantle the fuel lines on the high-pressure fuel system with the engine running. High pressure fuel spray from an operating engine can cause serious personal injury or fire hazard.

To change the fuel filters:

1. Shut off the engine.
2. Close any fuel valves (if equipped) to prevent fuel from draining or siphoning.
3. Clean the area around the fuel filter or fuel/water separator heads.

NOTE: Refer to the [engine data sheet](#) for filter replacement recommendations.

4. Remove the spent filter canisters using a filter wrench.
5. Clean the filter mounting head surfaces of sludge buildup and foreign particles. Ensure mating gasket surfaces are clean.
6. Lubricate the gasket seals with clean SAE 15W-40 lubricating oil.

7. Center the filter ring on the threaded mounting nipple. Screw the filter canister onto the mounting flange until the gasket is snug against the mounting flange, then tighten an additional 1/4 turn.
8. Open the fuel supply valves (if equipped).

CAUTION

Mechanical over-tightening can distort the threads or damage the filter element seal.

9. Press either the CRANK BATT A or CRANK BATT B button to start the engine to allow the fuel to flow through the system.
10. Depress the contactor switch for up to fifteen seconds or until the engine starts. Repeat up to three times, if necessary.

CAUTION

To prevent damage to the starter, do not engage the starting motor more than fifteen seconds. Wait fifteen seconds between each start attempt.

IMPORTANT: *If the engine does not start after three attempts, check the fuel supply system. Absence of blue or white exhaust smoke during cranking indicates no fuel is being delivered.*

NOTE: *Engines used in fire pumps or standby service are expected to immediately accelerate from crank to full load.*

5.4.5 Engine oil and filter

Engine oil becomes contaminated and essential oil additives are depleted with use. The amount of contamination is related to the total amount of fuel and oil consumed. Change the oil at least once annually.

NOTE: *For composite oil pans, always use a new sealing washer on the oil drain plug. Hold the external locking nut in place while tightening the oil drain plug.*

IMPORTANT: *If the engine oil is drained from the oil pan to make an engine repair, new oil must be used.*

WARNING

To reduce the possibility of personal injury, avoid direct contact of hot oil with your skin. Some state and federal agencies have determined that used engine oil can be carcinogenic. Prolonged, repeated contact can cause skin disorders or other bodily injury. Wash thoroughly after contact. Avoid inhalation of vapors and ingestion of used engine oil. Dispose of the oil in accordance with local environmental regulations.

To change the oil and filter to remove the contaminants suspended in the oil:

1. Operate the engine until the coolant temperature reaches 70 °C (158 °F). Shut the engine off.
2. Place an appropriate container under the oil pan drain plug. Refer to the [engine data sheet](#) for oil pan capacity.
3. Remove the oil drain plug and drain the oil immediately to make sure all the oil and suspended contaminants are removed from the engine.

4. Remove the oil filter (see [Figure 5-5](#)) following these steps:
 - a. Clean the area around the engine oil filter canister. Use a filter wrench to remove the filter.
 - b. Remove and discard the O-ring seal if it has remained attached to the mounting flange. Clean the filter mounting flange with a clean lint-free cloth.
 - c. Apply a light film of 15W-40 lubricating oil to the replacement filter gasket before installing the filter.
5. Fill the oil filter with a high-quality 15W-40 multi-viscosity lubricating oil, such as Premium Blue[®], or its equivalent.

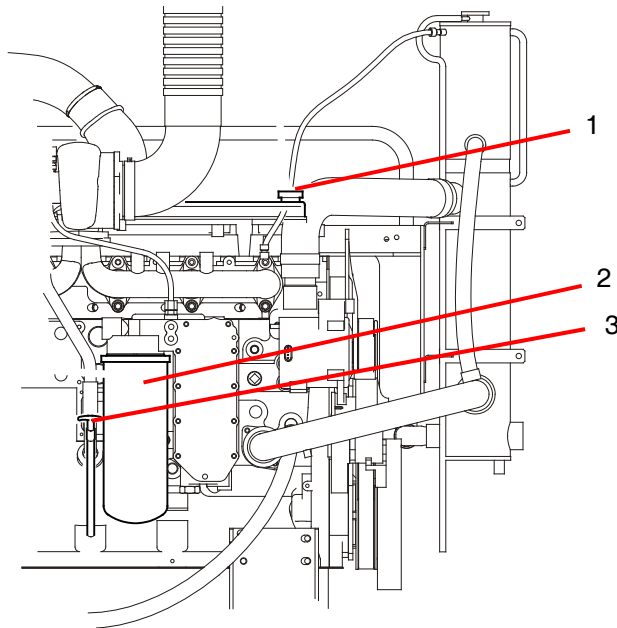

1. Engine oil fill port
2. Engine oil filter
3. Engine oil dipstick

Figure 5-5 Typical oil filter and oil level dipstick

6. Center the filter ring on the threaded mounting nipple. Screw the filter canister onto the mounting flange until the gasket is snug against the mounting flange. Then tighten an additional 1/4 turn.

CAUTION

Mechanical over-tightening can distort the threads or damage the filter element seal.

NOTE: Cummins recommends using oil filter replacement parts as outlined in the [engine data sheet](#).

7. Check and clean the oil pan drain plug threads and sealing surface. Install the oil pan drain plug. Torque the plug according to the [torque tables](#).
8. Fill the engine to the proper level with clean, high quality 15W-40 oil at the fill port.

 CAUTION

If no oil pressure is noted within fifteen seconds after the engine is started, shut down the engine to reduce the possibility of internal damage.

9. Restart the engine and let it run for approximately one to two minutes.
10. Stop the engine.
11. Wait approximately fifteen minutes to let the oil drain from the upper parts of the engine.
12. Check the oil level again. Add oil as necessary to bring the oil level to the H (high) mark on the dipstick.

5.4.6 Drive shaft

It is recommended that proper lubrication to drive shafts be completed on a regular schedule according to these steps:

1. Remove the drive shaft guards.
2. Wipe the grease fittings and grease gun nozzle with a clean cloth to avoid contamination.
3. Add grease to the drive shaft universal joint grease fittings (see [Figure 3-2](#)).
4. Wipe excess grease from the grease fittings.

NOTE: *Cummins recommends using a good quality semi-synthetic, molybdenum-fortified NLGI #2 lithium complex grease which protects from -47 to 204 °C (-54 to 400 °F).*

5.4.7 Coolant pump/alternator belt

On some engine models, the pump and alternator belt drives both the pump and alternator.

To inspect the coolant pump and the alternator belt:

1. Press the AUTO/MAN button on the FPDP to place the fire pump drive engine in MANUAL operation.
2. Disconnect both batteries at their terminals. Remove the negative (-) cable first.
3. Remove the belt guard capscrews and the belt guard. Set aside for re-installation (see [Figure 5-6](#)).

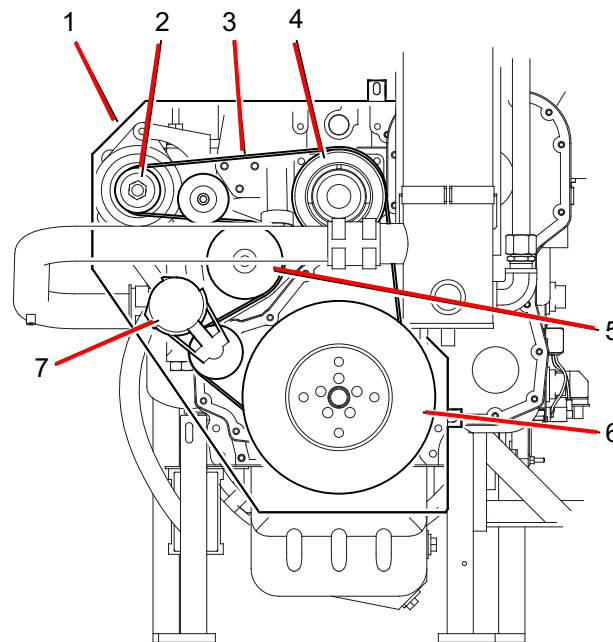

1. Belt guard
2. Alternator pulley
3. Drive belt
4. Idler pulley
5. Coolant pump pulley
6. Balancer pulley
7. Belt tensioner

Figure 5-6 Coolant pump/alternator belt (typical)

4. Visually inspect the belt for frayed, worn, missing pieces, or cracked belt surfaces. Check the belt for intersecting cracks.

CAUTION

Belt damage can be caused by: incorrect tension, incorrect size or length, pulley misalignment, incorrect installation, severe operating environment, and/or oil or grease on the belt or pulley.

NOTE: Transverse cracks (across the belt width) are acceptable. Longitudinal cracks (direction of belt length) that intersect with transverse cracks are not acceptable. Replace the belt if it is cracked, frayed, or damaged.

5. If the belt condition is acceptable, check the belt tension. Use the Cummins belt tension gauge (Part Number 3822524) to measure the drive belt tension in the center span of the belt between the idler and alternator pulleys. Ensure that the belt tension is set to the specifications outlined in the Engine Operation manual.

NOTE: Belts with glazed or shiny surfaces indicate belt slippage. Correctly installed and tensioned belts will show even pulley and belt wear.

CAUTION

Disconnect the batteries (negative cable first) before performing service on the fire pump drive engine or on any of its controls.

6. Reinstall the battery cables; attach the negative (-) battery cable last.

5.4.8 Raw water zinc anode

The zinc anode - part number 9750 - (see [Figure 5-7](#)) acts as a raw water filter and must be checked for erosion and replaced, when necessary. If the anode has eroded more than fifty percent, it must be replaced.

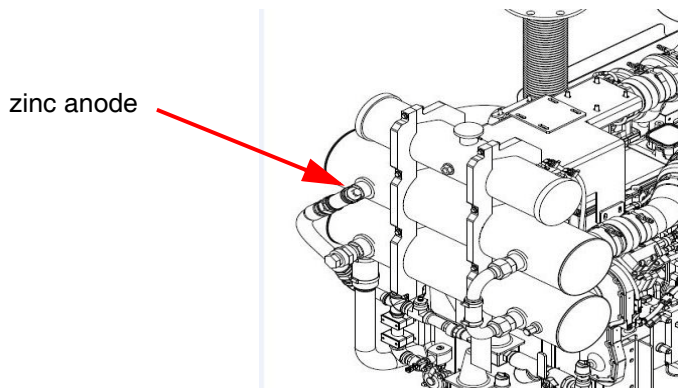

Figure 5-7 Raw water zinc anode (typical)

5.4.9 Heat exchanger pressure test

If internal leakage in the heat exchanger is suspected, a heat exchanger pressure test may be performed prior to removal from the engine.

NOTE: Use Teflon™ tape or other pipe sealant when installing the test setup in order to prevent leaks.

NOTE: The size of fittings required on the water outlets and inlets are listed on the [engine data sheet](#).

To test the heat exchanger pressure:

1. Install an adapter at the cooling water outlet of the heat exchanger.
2. Install a pressure test setup with 689 kPa (100 psi) pressure gauge at the cooling water inlet to the heat exchanger.

3. Apply air pressure at 276 kPa (40 psi).
 - a. Isolate the pressure source and monitor the pressure gauge for five minutes.
 - b. There should be no change in pressure for the duration of the test.
4. After testing, release the pressure. Remove the tubing adapters, plug, and test equipment.
5. If leakage is detected, the heat exchanger must be replaced.

5.4.10 Turbocharger

As shown in [Figure 5-3](#), follow these steps to thoroughly inspect the turbocharger:

1. Visually inspect the air intake filter and piping according to the steps outlined in Section [5.3.2](#).

NOTE: *Turbocharged engines must be operated at rated revolutions per minute (RPM) and full load to check maximum intake air restriction.*

NOTE: *Cummins recommends using an air cleaner filter element as listed on the [engine data sheet](#).*

CAUTION

Never operate the engine without an air cleaner. Intake air must be filtered to prevent dirt and debris from entering the engine and causing premature wear. Dirt or foreign objects could cause engine damage.

2. Remove the air intake and exhaust piping from the turbocharger.
3. Inspect the turbocharger turbine wheel for cracks in the housing or turbine blades, missing blades, mechanical binding, eccentric motion, or excessive end-play.
4. Replace the turbocharger if damage, excessive end-play, binding, wear, or eccentric motion is found. Contact a Cummins Authorized Repair Location for replacement.

IMPORTANT: *The turbocharger must be removed for replacement or rebuild if the clearance is beyond the limits, the housing is cracked, or the turbine wheel is damaged.*

5. Reinstall the air intake filter and exhaust piping. Tighten the clamps. Torque the loosened clamps to the recommended torque value. Refer to the [torque tables](#).

5.5 Every two years

All checks or inspections listed under daily or previous maintenance intervals must also be performed at this time, in addition to those listed under this maintenance interval.

5.5.1 Coolant pump

Inspect the coolant pump for eccentric motion, mechanical binding, excessive end play, seal damage, and excessive grease or coolant leakage around the pump shaft.

Replace with a new or rebuilt pre-lubricated unit, as necessary. Contact a Cummins Authorized Repair Location for replacement.

5.5.2 Cooling system - heat exchanger

Figure 5-8 illustrates the heat exchanger cooling system. The cooling system must be clean to work properly. If the system shows excessive mineral buildup, particulate matter, scale, oxidation, or oil contamination, drain and flush the cooling system. If the coolant is excessively dirty or is mixed with oil, contact a Cummins Authorized Repair Facility.

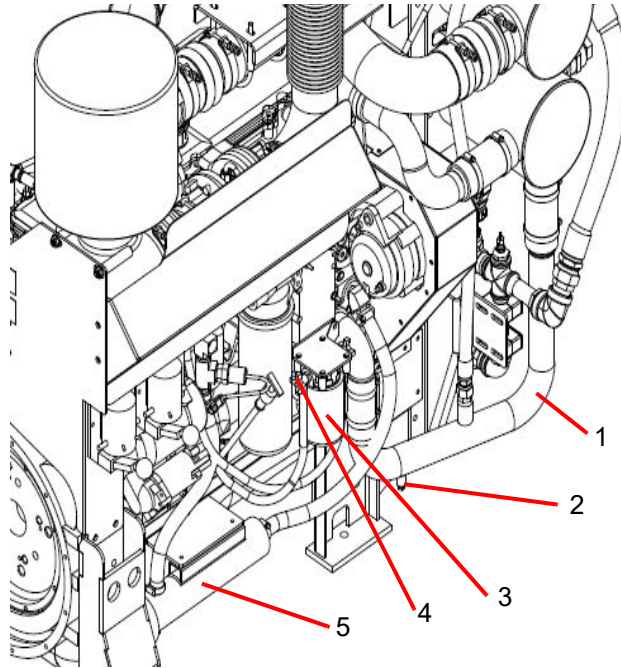

1. Lower coolant hose/tube
2. Coolant drain petcock
3. Coolant filter
4. Coolant filter shut-off valve
5. Engine coolant heater

Figure 5-8 Engine coolant drain - heat exchanger (typical)

WARNING

Do not remove the pressure/fill cap from a hot engine. Shut down the engine and wait until the coolant temperature is below 50 °C (120 °F) before removing the pressure cap. Heated coolant spray or steam can cause severe personal injury.

1. Disconnect both batteries at their terminals. Remove the negative (-) cable first.
2. Press down, unscrew, and remove the coolant expansion tank pressure/fill cap. The cap must be removed to allow air to vent the cooling system during the draining process.
3. Disconnect the engine coolant heater power supply before draining the cooling system.
4. Place a container that will hold at least 57 liters (15 gallons) of liquid under the coolant drain valve.
5. Ensure that the coolant filter shut-off valves are OPEN.
6. Open the drain petcock on the lower coolant tube, allowing the coolant to drain into the waste container.

7. When the system is empty, move the container under the engine coolant heater.
8. Disconnect either end of the engine heater coolant hose and drain the engine heater.

CAUTION

Coolant is toxic. Avoid prolonged and repeated skin contact with used antifreeze - wash thoroughly after contact. Prolonged, repeated contact can cause skin disorders. Dispose of waste antifreeze in accordance with local environmental regulations.

9. Flush with clean fresh water or heavy-duty heat exchanger cleaner. Follow the manufacturer's directions on the product container.

NOTE: *Some cooling system cleaners or commercial solvents require a soapy water rinse after use. Follow the directions on the cleaning solution or solvent.*

CAUTION

Over-concentration of antifreeze or use of high-silicate antifreeze can damage the engine. Do not use more than 50% antifreeze in the mixture unless additional freeze protection is required. Antifreeze at 68% concentration provides the maximum freeze protection, and must never be exceeded under any condition. Antifreeze protection decreases above 68%.

10. When the flushing water has fully drained, use a filter wrench to remove the water coolant filter from the filter housing.
 - a. Clean the filter housing gasket mount of dirt buildup, oxidation, or particulate matter with a clean cloth.
 - b. Coat the replacement filter gasket with a light coating of 15W-40 lubrication oil.
11. Center the filter ring on the threaded mounting nipple. Screw the filter canister onto the mounting flange until the gasket is snug against the mounting flange, then tighten an additional 1/4 turn. If using a soapy water solution, flush again with clear water. Allow time for the water to fully drain.

CAUTION

Mechanical over-tightening can distort the threads or damage the filter element seal.

NOTE: *Recommendations on filter replacements and fill rates can be found on the [Engine Data Sheet](#).*

12. Reconnect the engine heater coolant hose and close the drain petcock on the lower coolant tube.

NOTE: *During filling, air must be vented from the engine coolant passages. The air vents through the coolant filler port. The fill rate can be found in the [Engine Data Sheet](#).*

13. Fill the coolant tanks with the proper antifreeze. Use a mixture of 50% water and 50% ethylene-glycol base or propylene-glycol antifreeze (or pre-mixed solution) to protect the engine to -37 °C (-34 °F) year-around.

CAUTION

Use soft or distilled water in the coolant mixture. Contaminants in hard water neutralize the corrosion inhibitor components. Water must not exceed 300 ppm hardness or contain more than 100 ppm of either chloride or sulfate.

CAUTION

Never use a sealing additive to stop leaks in the cooling system. This can result in cooling system blockage or restricted coolant flow, causing the engine to overheat.

NOTE: Cummins recommends using Fleetguard® ES COMPLEAT™ Ethylene-Glycol (EG) or Fleetguard® Propylene-Glycol (PG) Plus™ Antifreeze/Coolants. Both products are available in concentrated or pre-mixed formulations. Use a 50% concentration level (40% to 60% range) of ethylene-glycol or propylene-glycol and Supplemental Coolant Additive (SCA) required for wet-sleeved engines in most climates. Contact your local Cummins Authorized Repair Location for additional information.

Ethylene-Glycol	Propylene-Glycol
40% = -23° C (-10° F)	40% = -21° C (-6° F)
50% = -37° C (-34° F)	50% = -33° C (-27° F)
60% = -54° C (-65° F)	60% = -54° C (-65° F)
68% = -71° C (-96° F)	68% = -63° C (-82° F)

CAUTION

The system must be filled properly to prevent air locks. During filling, air must be vented from the engine coolant passages.

14. Check the condition of the pressure/fill cap.
 - a. If the pressure/fill cap seal is worn, damaged, missing, or the pressure spring is damaged or shows signs of sticking, replace the filler cap.
 - b. Re-install the expansion tank fill cap.
15. Re-install the heater wiring.
16. Reinstall the battery cables; attach the negative (-) battery cable last.
17. Operate the engine until it reaches a temperature of 82 °C (180 °F), and check for coolant leaks.
18. Ensure that the coolant level is just below the fill neck and that the coolant heater is reconnected.

5.6 Every four years

All maintenance checks and inspections listed in previous maintenance intervals must also be performed at this time.

Cummins recommends performing maintenance on valve lash settings.

CAUTION

Disconnect both batteries (negative cable first) before performing service on the fire pump drive engine or on any of its controls. Wear safety glasses when disconnecting batteries!

CAUTION

Valve lash maintenance should be performed by a skilled technician. Improper maintenance can damage the engine or cause severe personal injury. Contact your local Cummins Authorized Repair Location before performing any extensive maintenance.

5.6.1 Coolant thermostat removal/installation

The thermostat regulates the temperature of the engine coolant circulating through the engine cooling system. Refer to the engine manual for complete instructions.

CAUTION

Always use the correct thermostat, and never operate the engine without a thermostat installed. The engine can overheat if operated without a thermostat because the path of least resistance for the coolant is through the bypass to the pump inlet.

1. As shown in [Figure 5-9](#), remove the upper coolant hose clamps and upper coolant hose at the thermostat housing.

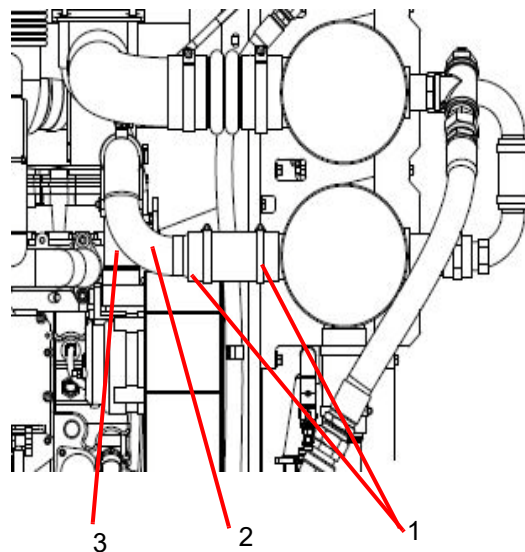

1. Hose clamps
2. Upper coolant hose
3. Thermostat housing

Figure 5-9 Typical thermostat housing

2. Remove the (2) thermostat housing flange cap screws and the thermostat flange.
3. Remove the thermostat and gasket from the housing.
4. Clean the housing flange faces of dirt buildup, oxidation, and sludge.
5. If still in good condition, re-install the thermostat in the housing.

IMPORTANT: *Inspect the seal on the thermostat housing flange surface and - if damaged or cracked - apply a new seal.*

NOTE: *Recommendations on thermostat replacement components can be found on the [engine data sheet](#).*

6. Replace the thermostat flange and cap screws.

5.6.2 Coolant pump/alternator belt replacement

Replace the coolant pump/alternator belt if it is cracked, frayed, or has pieces of material missing.

1. Remove the belt guard.
2. Use a 3/8" drive ratchet or breaker bar to rotate the tensioner arm away from the belt and remove the belt.
3. Check the belt tensioner cap screw torque. For recommended torque values, refer to the [torque tables](#).
4. Check the tensioner arm, pulley, and stops for cracks. If any cracks are noticed, the tensioner must be replaced.
5. Verify that the tensioner arm stop is not in contact with the spring casing stop. If either stop is touching, the tensioner must be replaced.
6. Inspect the tensioner for evidence of the tensioner arm contacting the tensioner cap.
7. If there is evidence of the two areas making contact, the pivot tube bushing has failed and the tensioner must be replaced.
8. Check the tensioner bearing.
9. Rotate the belt tensioner pulley. The pulley should spin freely with no mechanical binding, eccentric motion, or excessive end-play.
10. If the arm rotates with mechanical binding, eccentric movement, or excessive end play, replace the tensioner.
11. Inspect the clearance between the tensioner spring case and the tensioner arm for uneven bearing wear.
12. If the clearance exceeds 3 mm (0.12 in) at any point, the tensioner must be replaced as a complete assembly. Contact a Cummins Authorized Repair Location for replacement.

NOTE: *Experience has shown that tensioners generally will show a larger clearance gap near the lower portion of the spring case, resulting in the upper portion rubbing against the tensioner arm. Always replace the belt when a tensioner is replaced.*

13. After checking the torque, use a 3/8" drive ratchet or breaker bar to rotate the tensioner slowly away from the area of belt contact.
14. Install the replacement drive belt.

CAUTION

To prevent pulley or belt damage, do not roll a belt over the pulley or pry it on with a tool. Move the tensioner arm away from the belt area before installing the drive belt.

15. Check the location of the drive belt on the belt tensioner pulley. The belt should be centered on, or centered close to, the middle of the pulley.
16. Reinstall the belt guard.

CAUTION

Unaligned belts, either too far forward or backward, can cause belt wear, belt roll-off failures or increase uneven tensioner bushing wear.

6 - Troubleshooting

6.1 Introduction

The following information is intended as a guide for some common non-technical equipment problems. The first part of this section includes troubleshooting charts that cross-reference the problem, the possible cause, and the solution. The second section includes complete Fault Code charts outlining a numerical listing of fault codes and their descriptions.

Many problems can be resolved using corrective maintenance, adjustment, or minor repair. Refer to the vendor supplied literature, electrical schematics, and mechanical prints for additional information.

For engine-related issues, refer to the engine Operation and Maintenance Manual or contact the Cummins Customer Assistance Center at 1-800-CUMMINS (1-800-286-6467).

⚠ WARNING

*The status checks should be performed **ONLY** by a qualified technician. Contact with exposed electrical components could cause extreme personal injury or death.*

⚠ WARNING

*Before equipment operation, **ALL** guards, covers, and protective devices **MUST BE** in place and securely fastened. Serious personal injury could result from contact with exposed or moving components.*

⚠ CAUTION

***AVOID SERVICING** complex components such as: printed circuit boards, programmable controllers, and ECMs not specifically authorized by Cummins. Contact the Cummins Customer Service Department toll free at 1-800-343-7357 before performing any extensive maintenance.*

⚠ CAUTION

Never climb or stand on the equipment frame, guards, or enclosures. Contact with exposed or moving components can cause personal injury or equipment damage.

6.2 Engine Will Not Start

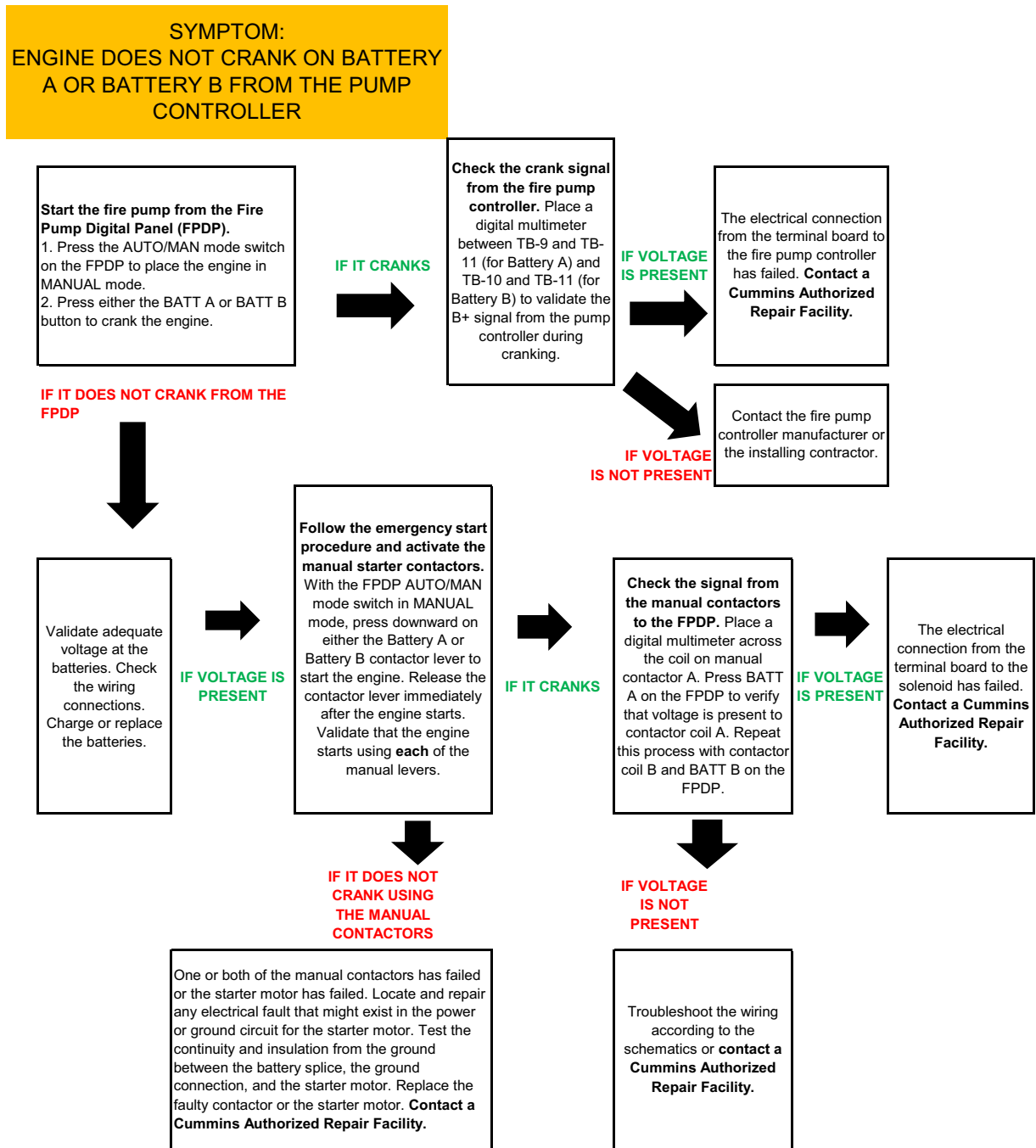

6.3 Engine Cranks But Will Not Start

SYMPTOM:
ENGINE CRANKS FROM THE PUMP CONTROLLER, BUT WILL NOT START (NO EXHAUST SMOKE)

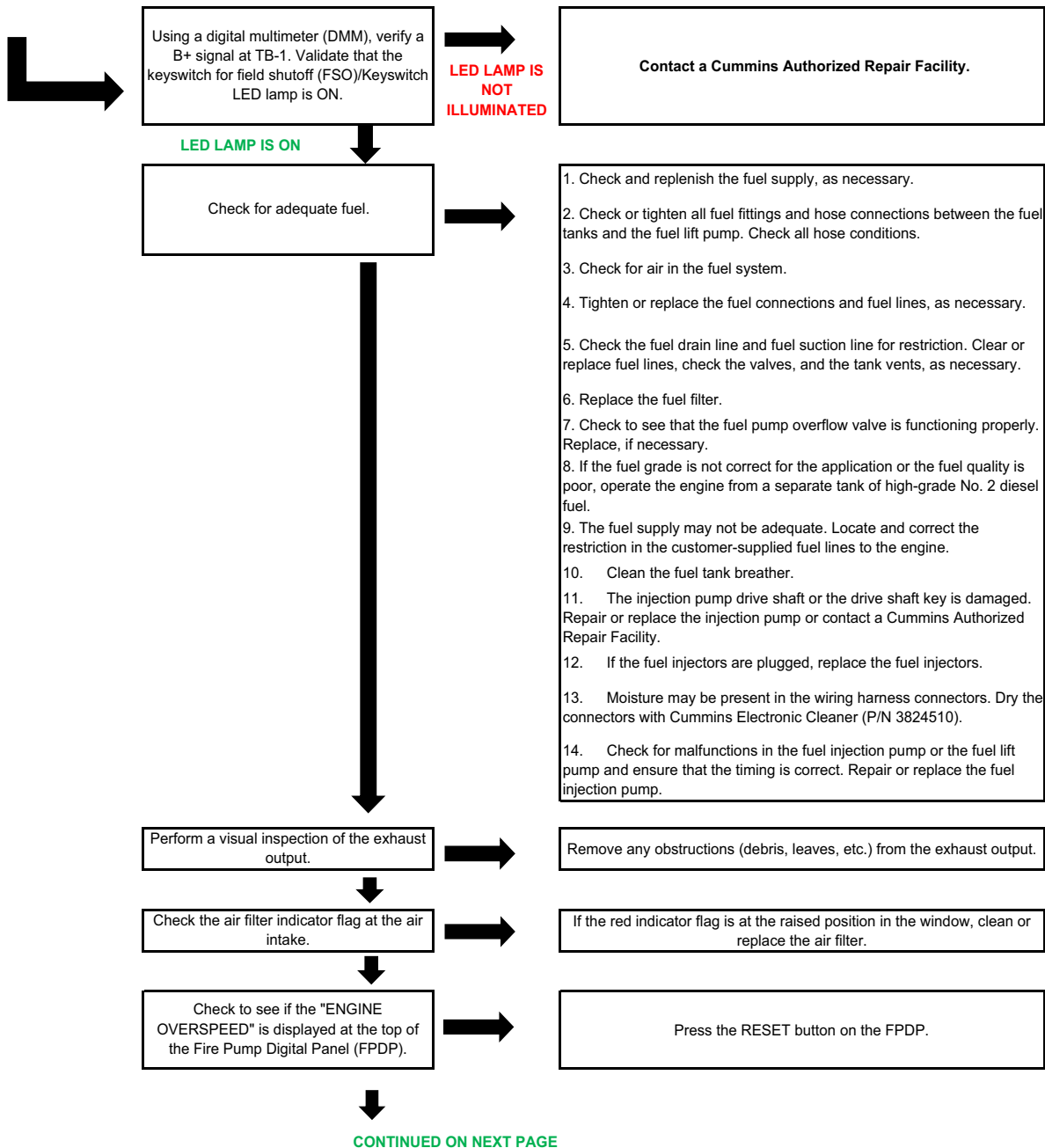

Engine Cranks But Will Not Start (cont.)

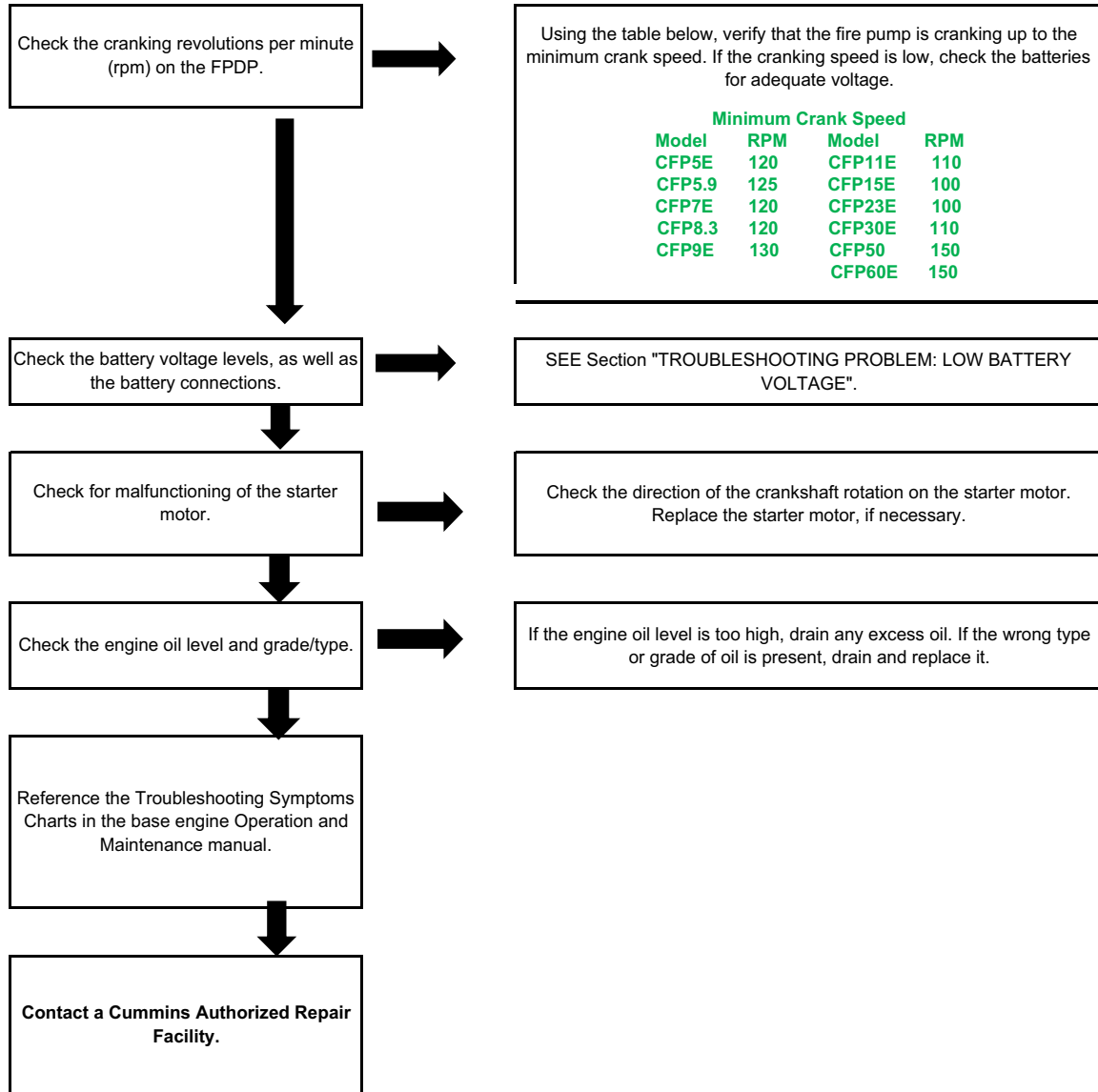

6.4 Engine Starts But Continues to Crank

STOP THE ENGINE AT THE FIRE PUMP CONTROLLER (PLACE THE CONTROLLER IN THE OFF POSITION) AND TROUBLESHOOT FROM THE FIRE PUMP DRIVE ENGINE:

PRIOR TO MAKING A SERVICE CALL, PERFORM A VISUAL INSPECTION:

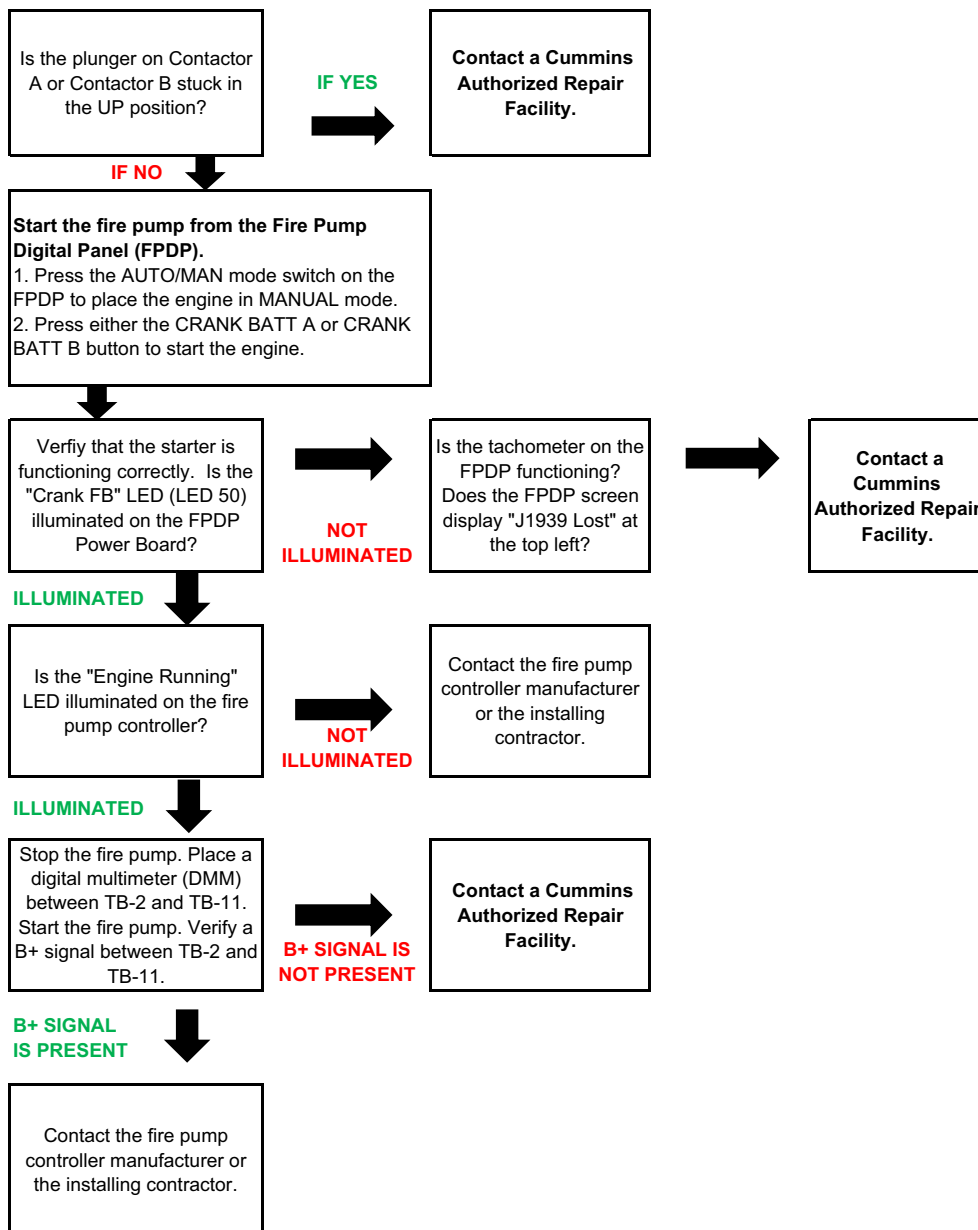

6.5 Engine Will Not Stop

TO STOP THE ENGINE:

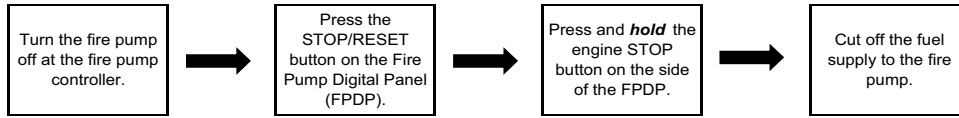

TO TROUBLESHOOT THIS PROBLEM, ONCE THE FIRE PUMP HAS STOPPED:

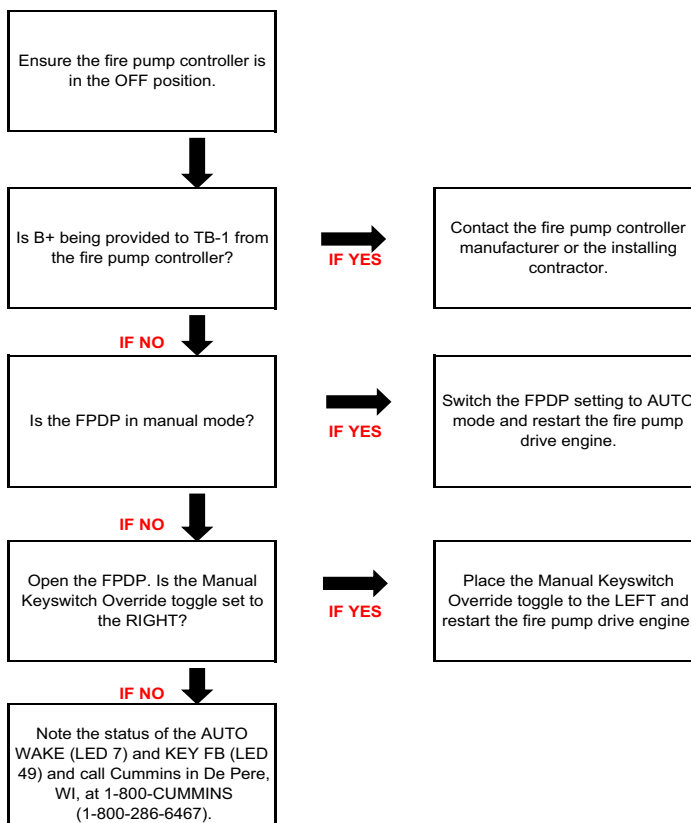

6.6 Low Battery Voltage

PROBLEM: LOW BATTERY VOLTAGE

SYMPTOM: The Fire Pump Digital Panel (FPDP) will momentarily "blink" upon starting or the fire pump drive engine is slow to crank. There is a high probability that the engine will not start.

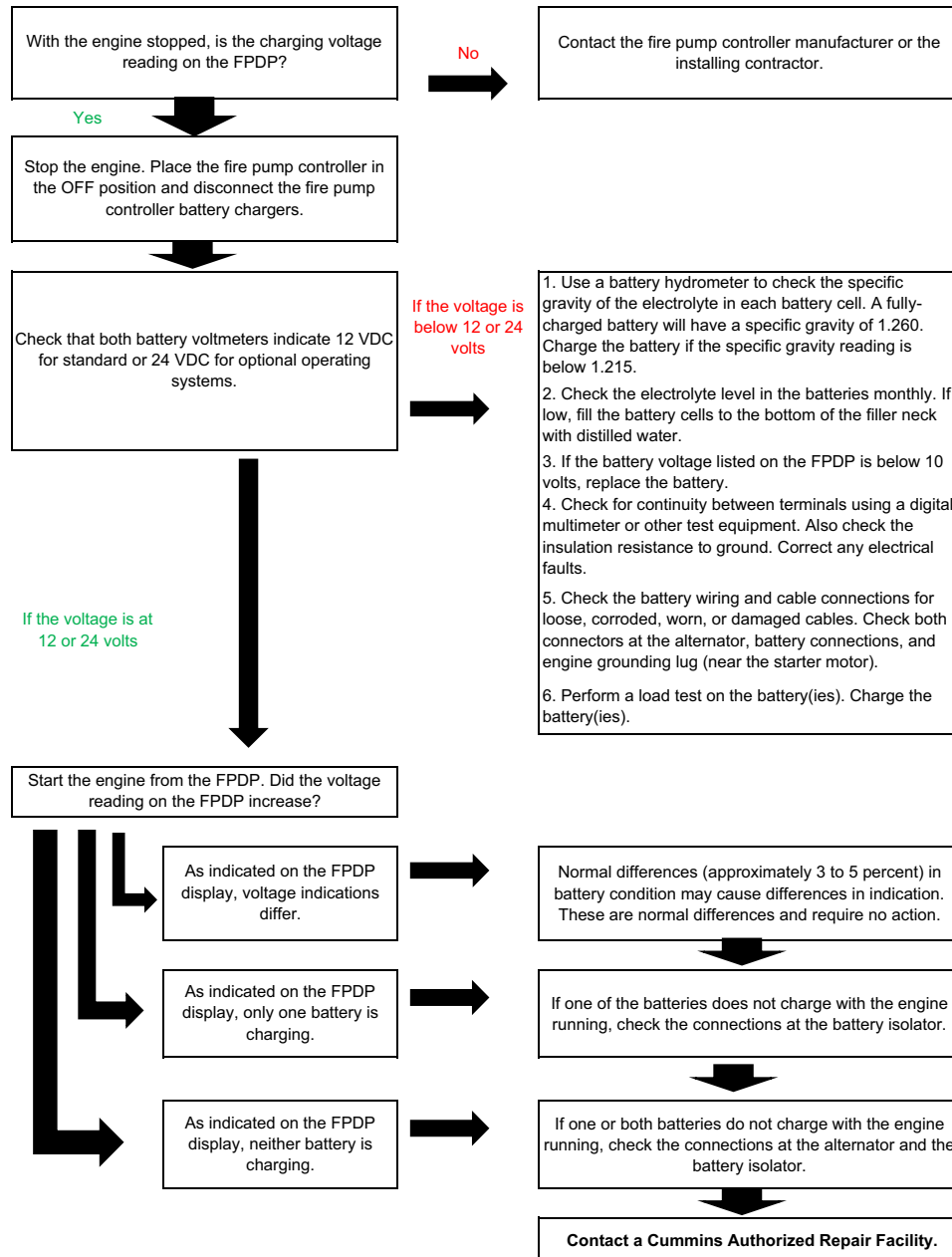

6.7 Fault Code Charts - CFP15E/EVS, CFP23E/EVS, CFP30E, and CFP60E

The following tables specify the fault codes and their meanings for the CFP15E/EVS, CFP23E/EVS, CFP30E, and CFP60E model fire pump drive engines:

Table 6-1. CFP15E, CFP23E, CFP30E, CFP60E FAULT CODES

FAULT CODE (LAMP)	SPN	FMI	LAMP COLOR	CUMMINS DESCRIPTION	FIM FAULT	ECM AUTO SWITCH
111	629	12	RED	Engine Control Module - Critical internal failure		X
112	635	7	RED	Engine Timing Actuator is not responding to ECM commands		
113	635	3	YELLOW	Engine Timing Actuator Circuit - shorted high		
114	635	4	YELLOW	Engine Timing Actuator Circuit - shorted low		
115	190	2	RED	Engine Speed/Position Sensor Circuit - lost both of two signals from the magnetic pickup sensor	X	
116	156	3	RED	Fuel Timing Pressure Sensor Circuit - shorted high	X	
117	156	4	RED	Fuel Timing Pressure Sensor Circuit - shorted low	X	
118	135	3	YELLOW	Fuel Pump Delivery Pressure Sensor Circuit - shorted high	X	
119	135	4	YELLOW	Fuel Pump Delivery Pressure Sensor Circuit - shorted low	X	
121	190	10	YELLOW	Engine Speed/Position Sensor Circuit - lost one of two signals from the magnetic pickup sensor	X	
122	102	3	YELLOW	Intake Manifold Pressure Sensor #1 Circuit - shorted high		
123	102	4	YELLOW	Intake Manifold Pressure Sensor #1 Circuit - shorted low		
124	102	16	YELLOW	High Intake Manifold Pressure Left Bank		
125	102	18		Low Intake Manifold Pressure Left Bank		
126	1129	16	YELLOW	High Intake Manifold Pressure Right Bank		
127	1129	18		Low Intake Manifold Pressure Left Bank		
128	1129	3		Right Bank Intake Manifold Pressure Sensor Circuit Failed High		
129	1129	4		Right Bank Intake Manifold Pressure Sensor Circuit Failed Low		
131	91	3	RED	Accelerator Pedal Position Sensor Circuit - shorted high		
132	91	4	RED	Accelerator Pedal Position Sensor Circuit - shorted low		
133	974	3	RED	Remote Accelerator Pedal Position Sensor Circuit - shorted high		
133	29	3	RED	Remote Accelerator Pedal Position Sensor Circuit - shorted high		

134	974	4	RED	Remote Accelerator Pedal Position Sensor Circuit - shorted low		
134	29	4	RED	Remote Accelerator Pedal Position Sensor Circuit - shorted low		
135	100	3	YELLOW	Engine Oil Pressure Sensor Circuit - shorted high		
136	1208	3		Pre Filter Oil Pressure Sensor Circuit Failed High		
137	1208	4		Pre Filter Oil Pressure Sensor Circuit Failed Low		
141	100	4	YELLOW	Engine Oil Pressure Sensor Circuit - shorted low		
143	100	18	YELLOW	Engine Oil Pressure Low - Warning		
143	100	1	RED	Engine Oil Pressure Low - Warning		
144	110	3	YELLOW	Engine Coolant Temperature Sensor Circuit - shorted high		
145	110	4	YELLOW	Engine Coolant Temperature Sensor Circuit - shorted low		
147	91	8	RED	Accelerator Pedal Position Sensor Circuit - low frequency		
148	91	8	RED	Accelerator Pedal Position Sensor Circuit - high frequency		
151	110	0	RED	Engine Coolant Temperature High - Critical		
153	105	3	YELLOW	Intake Manifold Temperature Sensor #1 Circuit - shorted high		
154	105	4	YELLOW	Intake Manifold Temperature Sensor #1 Circuit - shorted low		
155	105	0	RED	Intake Manifold Temperature #1 High - Critical		
166	733	3	YELLOW	Rack Position Sensor #1 Circuit - shorted high		
172	638	6	RED	Rack Actuator Position #1 Circuit - grounded circuit		
173	638	7	YELLOW	Rack Actuator - mechanically stuck open		
184	609	2	YELLOW	Engine Control Module Identification Input State Error		X
185	639	2	YELLOW	Engine Control Module Network Communication Error		X
187	620	4	YELLOW	Sensor Supply Voltage #2 Circuit - shorted low		
211	1484	31		Additional OEM/Vehicle Diagnostic Codes have been logged.		
212	175	3	YELLOW	Engine Oil Temperature Sensor Circuit - shorted high		
213	175	4	YELLOW	Engine Oil Temperature Sensor Circuit - shorted low		
214	175	0	RED	Engine Oil Temperature High - Critical		
221	108	3	YELLOW	Ambient Air Pressure Sensor circuit - shorted high		
222	108	4	YELLOW	Ambient Air Pressure Sensor circuit - shorted low		

Troubleshooting

223	1265	4	YELLOW	Engine Oil Burn Valve Solenoid Circuit - shorted low		
225	1266	4	YELLOW	Engine Oil Replacement Valve Solenoid Circuit - shorted low		
227	620	3	YELLOW	Sensor Supply Voltage #2 Circuit - shorted high		
231	109	3	YELLOW	Engine Coolant Pressure Sensor Circuit - shorted high		
232	109	4	YELLOW	Engine Coolant Pressure Sensor Circuit - shorted low		
233	109	1	RED	Engine Coolant Pressure Low - Warning		
233	109	18	YELLOW	Engine Coolant Pressure Low - Warning		
234	190	0	RED	Engine Speed High - Critical	X	
235	111	1	RED	Engine Coolant Level Low - Critical		
237	644	2	YELLOW	External Speed Input (Multiple Unit Synchronization) - data incorrect		
241	84	2	YELLOW	Vehicle Speed Sensor Circuit - data incorrect	X	
242	84	10	YELLOW	Vehicle Speed Sensor Circuit - tampering has been detected	X	
245	647	4	YELLOW	Fan Clutch Circuit - shorted low		
254	632	4	RED	Fuel Shutoff Valve Circuit - shorted low	X	
255	632	3	YELLOW	Fuel Shutoff Valve Circuit - shorted high	X	
259	632	7	RED	Fuel Shutoff Valve - Stuck Open	X	
261	174	0	RED	Fuel Temperature High - Warning	X	
263	174	3	YELLOW	Fuel Temperature Sensor Circuit - shorted high	X	
265	174	4	YELLOW	Fuel Temperature Sensor Circuit - shorted low	X	
284	1043	4	YELLOW	Engine Speed / Position Sensor #1 (Crankshaft) Supply Voltage Circuit - shorted low	X	
285	639	9	YELLOW	SAE J1939 Multiplexing PGN Timeout Error		
286	639	13	YELLOW	SAE J1939 Multiplexing Configuration Error		
287	91	19	RED	SAE J1939 Multiplexing Accelerator Pedal Sensor System Error		
288	974	19	RED	SAE J1939 Multiplexing Remote Throttle Data Error		
292	1083	14	RED	Auxiliary Temperature Sensor Input #1 Engine Protection - Critical		
293	1083	3	YELLOW	Auxiliary Temperature Sensor Input #1 Circuit - shorted high		
294	1083	4	YELLOW	Auxiliary Temperature Sensor Input #1 Circuit - shorted low		
295	108	2	YELLOW	Ambient Air Pressure Sensor Circuit - data incorrect		

296	1084	14	RED	Auxiliary Pressure Sensor Input #2 Engine Protection - Critical		
297	1084	3	YELLOW	Auxiliary Pressure Sensor Input #2 Circuit - shorted high		
298	1084	4	YELLOW	Auxiliary Pressure Sensor Input #2 Circuit - shorted low		
299	1384	31		Engine Shutdown Commanded by J1939		
311	651	6	YELLOW	Injector Solenoid Valve Cylinder #1 Circuit - grounded circuit	X	
312	655	6	YELLOW	Injector Solenoid Valve Cylinder #5 Circuit - grounded circuit	X	
313	653	6	YELLOW	Injector Solenoid Valve Cylinder #3 Circuit - grounded circuit	X	
314	656	6	YELLOW	Injector Solenoid Valve Cylinder #6 Circuit - grounded circuit	X	
315	652	6	YELLOW	Injector Solenoid Valve Cylinder #2 Circuit - grounded circuit	X	
316	931	3	YELLOW	Fuel Supply Pump Actuator Circuit - shorted high	X	
318	931	7	YELLOW	Fuel Supply Pump Actuator - mechanically stuck	X	
319	251	2		Real Time Clock - Power Interrupt		
321	654	6	YELLOW	Injector Solenoid Valve Cylinder #4 Circuit - grounded circuit	X	
322	651	5	YELLOW	Injector Solenoid Valve Cylinder #1 Circuit - open circuit	X	
323	655	5	YELLOW	Injector Solenoid Valve Cylinder #5 Circuit - open circuit	X	
324	653	5	YELLOW	Injector Solenoid Valve Cylinder #3 Circuit - open circuit	X	
325	656	5	YELLOW	Injector Solenoid Valve Cylinder #6 Circuit - open circuit	X	
331	652	5	YELLOW	Injector Solenoid Valve Cylinder #2 Circuit - open circuit	X	
332	654	5	YELLOW	Injector Solenoid Valve Cylinder #4 Circuit - open circuit	X	
341	630	2	YELLOW	Engine Control Module - data lost		X
342	630	13	RED	Engine Control Module - Out of Calibration		X
343	629	12	YELLOW	Engine Control Module - Warning Internal Hardware Failure		X
346	630	12	YELLOW	Engine Control Module - Warning Software error		
349	191	16	YELLOW	Transmission Output Shaft (Tailshaft) Speed High - Warning		
349	191	0	YELLOW	Transmission Output Shaft (Tailshaft) Speed High - Warning		
352	1079	4	YELLOW	Sensor Supply Voltage #1 Circuit - shorted low		
378	633	5	YELLOW	Fueling Actuator #1 Circuit - Open Circuit	X	

Troubleshooting

379	633	6	YELLOW	Fueling Actuator #1 Circuit - Grounded Circuit	X	
384	626	11	YELLOW	Start Assist Device Control Circuit Error (Ether Injection)		
386	1079	3	YELLOW	Sensor Supply Voltage #1 Circuit - shorted high		
387	1043	3	YELLOW	Accelerator Pedal Position Sensor Supply Voltage Circuit - shorted high		
394	635	5	YELLOW	Timing Actuator #1 Circuit - Open Circuit		
395	635	6	YELLOW	Timing Actuator #1 Circuit - grounded circuit		
396	1244	5	YELLOW	Fueling Actuator #2 Circuit - open circuit	X	
397	1244	6	YELLOW	Fueling Actuator #2 Circuit - grounded circuit	X	
398	1245	5	YELLOW	Timing Actuator #2 Circuit - open circuit		
399	1245	6	YELLOW	Timing Actuator #2 Circuit - Grounded Circuit		
414	608	9	YELLOW	Data Communication error over the J1587 data link circuit		
415	100	1	RED	Engine Oil Pressure Low - Critical		
418	97	15		Water in Fuel Indicator High - Maintenance		
419	1319	2	YELLOW	Intake Manifold Boost Pressure Imbalance		
422	111	2	YELLOW	Engine Coolant Level Sensor Circuit - data incorrect		
423	156	2	YELLOW	Fuel Timing Pressure or Timing Actuator stuck	X	
426	639	2		SAE J1939 datalink - cannot transmit		X
427	639	9		SAE J1939 not fast enough		X
428	97	3	YELLOW	Water in Fuel Sensor Circuit - shorted high		
429	97	4	YELLOW	Water in Fuel Sensor Circuit - shorted low		
431	558	2	YELLOW	Accelerator Pedal Idle Validation Circuit - data incorrect		
431	91	2	YELLOW	Accelerator Pedal Idle Validation Circuit - data incorrect		
432	558	13	RED	Accelerator Pedal Idle Validation Circuit - Our of Calibration		
432	91	13	RED	Accelerator Pedal Idle Validation Circuit - Our of Calibration		
433	102	2	YELLOW	Intake Manifold Pressure Sensor Circuit - data incorrect		
434	627	2	YELLOW	Power Lost without Ignition Off		
435	100	2	YELLOW	Engine Oil Pressure Sensor Circuit - data incorrect		
441	168	18	YELLOW	Battery #1 Voltage Low - Warning		
441	168	1		Battery #1 Voltage Low - Warning		
442	168	16	YELLOW	Battery #1 Voltage High- Warning		

443	1043	4	YELLOW	Accelerator Pedal Position Sensor Supply Voltage Circuit - shorted low		
449	94	16	YELLOW	Fuel Pressure High - Warning	X	
451	157	3	YELLOW	Injector Metering Rail #1 Pressure Sensor Circuit - Shorted High	X	
452	157	4	YELLOW	Injector Metering Rail #1 Pressure Sensor Circuit - Shorted Low	X	
455	633	3	RED	Fuel Control Valve Circuit - shorted high	X	
466	1188	4	YELLOW	Turbocharger #1 Wastegate Control Circuit - shorted low		
467	635	2	YELLOW	Timing Rail Actuator Circuit - data incorrect		
468	633	2	YELLOW	Fuel Rail Actuator Circuit - data incorrect	X	
479	1318	9		Exhaust Port Temperature Bank Imbalance		
482	94	18	YELLOW	Fuel Pressure Low - Warning	X	
483	1349	3	YELLOW	Injector Metering Rail #2 Pressure Sensor Circuit - Shorted High	X	
484	1349	4	YELLOW	Injector Metering Rail #2 Pressure Sensor Circuit - Shorted Low	X	
485	1349	16	YELLOW	Injector Metering Rail #2 Pressure High - Warning	X	
486	1349	18	YELLOW	Injector Metering Rail #2 Pressure Low - Warning	X	
487	626	1		Start Assist Device - Canister Empty (Ether Injection)		
489	191	18	YELLOW	Transmission Output Shaft (Tailshaft) Speed Low - Warning		
489	191	1	YELLOW	Transmission Output Shaft (Tailshaft) Speed Low - Warning		
496	1043	11	YELLOW	Engine Speed/Position Sensor #2 (Camshaft) Supply Voltage	X	
497	1377	2	YELLOW	Multiple Unit Synchronization Switch Circuit - data incorrect		
514	633	7	RED	Fuel Control Valve - mechanically stuck	X	
524	113	2	YELLOW	OEM Alternate Droop Switch Validation - data incorrect		
527	702	3	YELLOW	Auxiliary Input/Output #2 Circuit - shorted high		
528	93	2	YELLOW	OEM Alternate torque validation switch - data incorrect		
529	703	3	YELLOW	Auxiliary Input/Output #3 Circuit - shorted high		
546	94	3	YELLOW	Fuel Delivery Pressure Sensor Circuit - shorted high	X	
547	94	4	YELLOW	Fuel Delivery Pressure Sensor Circuit - shorted low	X	
551	558	4	YELLOW	Accelerator Pedal Idle Validation Circuit - shorted low		

Troubleshooting

551	91	4	RED	Accelerator Pedal Idle Validation Circuit - shorted low		
553	157	16	YELLOW	Injector Metering Rail #1 Pressure High - Warning Level	X	
554	157	2	YELLOW	Fuel Pressure Sensor Error	X	
555	1264	16	YELLOW	Engine Blowby - Warning Level		
555	1264	0	RED	Engine Blowby - Warning Level		
581	1381	3	YELLOW	Fuel Supply Pump Inlet Pressure Sensor Circuit - shorted high	X	
582	1381	4	YELLOW	Fuel Supply Pump Inlet Pressure Sensor Circuit - shorted low	X	
583	1381	18	YELLOW	Fuel Supply Pump Inlet Pressure Low - warning level	X	
595	103	16	YELLOW	Turbocharger #1 Speed High - warning level		
596	167	16	YELLOW	Electrical Charging System Voltage High - warning level		
597	167	18	YELLOW	Electrical Charging System Voltage Low - warning level		
598	167	1	RED	Electrical Charging System Voltage Low - critical level		
611	1383	31		Engine Hot Shutdown		
612	99	1	RED	High Lubricating Oil Filter Restriction		
617	1172	0		High Turbo Compressor Inlet Temperature LB		
621	1137	18	YELLOW	Low #1 LB Cylinder Power		
622	1138	18	YELLOW	Low #2 LB Cylinder Power		
623	1139	18	YELLOW	Low #3 LB Cylinder Power		
624	1140	18	YELLOW	Low #4 LB Cylinder Power		
625	1141	18	YELLOW	Low #5 LB Cylinder Power		
626	1142	18	YELLOW	Low #6 LB Cylinder Power		
631	1329	1	YELLOW	Low #1 RB Cylinder Power		
632	1329	1	YELLOW	Low #2 RB Cylinder Power		
633	1329	1	YELLOW	Low #3 RB Cylinder Power		
634	1329	1	YELLOW	Low #4 RB Cylinder Power		
635	1329	1	YELLOW	Low #5 RB Cylinder Power		
636	1329	1	YELLOW	Low #6 RB Cylinder Power		
641	1137	0	RED	High #1 LB Cylinder Exhaust Temperature		
642	1138	0	RED	High #2 LB Cylinder Exhaust Temperature		
643	1139	0	RED	High #3 LB Cylinder Exhaust Temperature		

644	1140	0	RED	High #4 LB Cylinder Exhaust Temperature		
645	1141	0	RED	High #5 LB Cylinder Exhaust Temperature		
646	1142	0	RED	High #6 LB Cylinder Exhaust Temperature		
649	1378	0		Change Lubricating Oil and Filter		
651	1143	0	RED	High #1 RB Cylinder Exhaust Temperature		
	1145	0	RED			
652	1144	0	RED	High #2 RB Cylinder Exhaust Temperature		
	1146	0	RED			
653	1145	0	RED	High #3 RB Cylinder Exhaust Temperature		
	1147	0	RED			
654	1146	0	RED	High #4 RB Cylinder Exhaust Temperature		
	1148	0	RED			
655	1147	0	RED	High #5 RB Cylinder Exhaust Temperature		
	1149	0	RED			
656	1148	0	RED	High #6 RB Cylinder Exhaust Temperature		
	1149	0	RED			
661	1323	0	YELLOW	High #1 LB Cylinder Power		
662	1324	0	YELLOW	High #2 LB Cylinder Power		
663	1325	0	YELLOW	High #3 LB Cylinder Power		
664	1326	0	YELLOW	High #4 LB Cylinder Power		
665	1327	0	YELLOW	High #5 LB Cylinder Power		
666	1328	0	YELLOW	High #6 LB Cylinder Power		
671	1137	4		Cylinder #1 LB Exhaust Temperature Sensor Failed Low		
672	1138	4		Cylinder #2 LB Exhaust Temperature Sensor Failed Low		
673	1139	4		Cylinder #3 LB Exhaust Temperature Sensor Failed Low		
674	1140	4		Cylinder #4 LB Exhaust Temperature Sensor Failed Low		
675	1141	4		Cylinder #5 LB Exhaust Temperature Sensor Failed Low		
676	1142	4		Cylinder #6 LB Exhaust Temperature Sensor Failed Low		
691	1172	3		LBF Turbo Comp Inlet Temperature Sensor Failed High		
692	1172	4		LBF Turbo Comp Inlet Temperature Sensor Failed Low		

Troubleshooting

711	1329	0	YELLOW	High #1 RB Cylinder Power		
712	1330	0	YELLOW	High #2 RB Cylinder Power		
713	1331	0	YELLOW	High #3 RB Cylinder Power		
714	1332	0	YELLOW	High #4 RB Cylinder Power		
715	1333	0	YELLOW	High #5 RB Cylinder Power		
716	1334	0	YELLOW	High #6 RB Cylinder Power		
719	1264	3	YELLOW	Crankcase Blowby Pressure Sensor Circuit - shorted high		
721	1143	4		Cylinder #1 RB Exhaust Temperature Sensor Failed Low		
	1145	4				
722	1144	4		Cylinder #2 RB Exhaust Temperature Sensor Failed Low		
	1146	4				
723	1145	4		Cylinder #3 RB Exhaust Temperature Sensor Failed Low		
	1147	4				
724	1146	4		Cylinder #4 RB Exhaust Temperature Sensor Failed Low		
	1148	4				
725	1147	4		Cylinder #5 RB Exhaust Temperature Sensor Failed Low		
	1149	4				
726	1148	4		Cylinder #6 RB Exhaust Temperature Sensor Failed Low		
	1149	4				
729	1264	4	YELLOW	Crankcase Blowby Pressure Sensor Circuit - shorted low		
753	723	2		Engine Speed/Position #2 - Cam sync error	X	
758	1349	7	YELLOW	Injector Metering Rail #2 Pressure Malfunction	X	
951	166	2		Cylinder Power Imbalance between cylinders		
2155	611	4		Post-Filter Oil Pressure Sensor Circuit - shorted low		

Table 6-2.

7 - Component parts and assemblies

7.1 Repairs and technical service

Personnel at Cummins Authorized Repair Locations can assist you with the correct operation and service of your engine. Cummins has a worldwide service network of more than 5,000 Distributors and Dealers who have been trained to provide sound advice, expert service, and complete parts support. Check the telephone directory yellow pages or refer to the directory in this section for the nearest Cummins Authorized Repair Location. Outside of North America, contact your regional office. Telephone numbers and addresses are listed in the International Directory.

If assistance is required, call toll-free: 1-800-CUMMINS. Includes all 50 states, Bermuda, Puerto Rico, Virgin Islands, and the Bahamas. The Cummins Customer Assistance Center provides 24-hour assistance to aid in technical and emergency service when a Cummins Authorized Repair Location cannot be reached or is unable to resolve an issue with a Cummins product.

Refer also to the Cummins Inc. website at cummins.com.

7.2 Recommended spare parts inventory

To minimize downtime and increase productivity, Cummins Inc. recommends maintaining a stock of spare parts critical to uninterrupted engine operation. Shipping costs can be lower using ground transportation rather than overnight or next day air freight. For this reason, Cummins Inc. can provide a list of recommended spare parts. Contact a Cummins Authorized Repair Location for additional information.

7.3 Ordering parts

Replacement parts for the Cummins Inc. equipment are manufactured to the same quality standards and specifications as the original equipment. Unapproved substitution may result in poor performance, reduced service life, lost production, or unsafe operation.

Cummins Inc. relies on the best and most cost effective shipping methods, unless specific instructions or requirements are requested by the customer. When ordering parts, please be prepared to provide the following information:

- Model and serial number
- Part description by name
- Quantity required
- Purchase order number

NOTE: *A purchase order number is desirable, even if the part(s) are supplied on a Returned Goods Authorization (RGA) issue number. A purchase order number helps Cummins and its customer track the parts and necessary credits.*

7.4 Engine data and torque values

The following pages outline applicable reference material that represents the engine data for the CFP15E and all its ratings at the time of this printing. For a complete, up-to-date, Model Specification Sheet, refer to cummins.com.

CFP15E/EVS F10-F30

Air induction system

Maximum temperature rise between ambient air and engine air inlet	30 °F (16.7 °C)
Maximum inlet restriction with dirty filter	25 in. H ₂ O (635 mm H ₂ O)
Recommended air cleaner element - (standard)	K&N Serviceable/Disposable RC-3070
Recommended air cleaner element - (heavy duty)	Optional: primary element AF25544; secondary element AF25545

Lubrication system

Oil pressure range at rated	35-40 PSI (242-276 kPa)
Oil capacity of pan (high - low)	48-40 qt. (45-38 L)
Total system capacity	13 gal. (49 L)
Recommended lube oil filter	Cummins Filtration LF9000

Cooling system*

Raw water working pressure range at heat exchanger	60 PSI (413 kPa) MAX
Recommended minimum water supply pipe size to heat exchanger	1 in. (25.4 mm)
Recommended minimum water discharge pipe size from heat exchanger	1.25 in. (31.75 mm)
Coolant water capacity (engine only)	13.9 gal. (52.6 L)
Standard thermostat - type	Modulating
Standard thermostat - range	180-200 °F (82-93 °C)
Normal operating temperature	180-212 °F (82-100 °C)
Minimum raw water flow:	
- with water temperatures to 60 °F (16 °C)	24.8 GPM (1.56 L/sec)
- with water temperatures to 80 °F (27 °C)	26.4 GPM (1.67 L/sec)
- with water temperatures to 100 °F (38 °C)	28 GPM (1.77 L/sec)
Recommended cooling water filter	Cummins Filtration WF2126

* A jacket water heater is mandatory on this engine. The recommended heater wattage is 3000 down to 40 °F (4 °C)

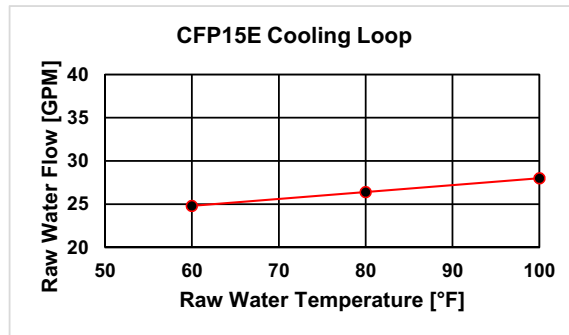

Exhaust system

Maximum allowable back pressure by complete exhaust system	40.8 in. H ₂ O (10.2 kPa)
Exhaust pipe size normally acceptable	6 in. (152 mm)

Noise emissions - The noise emission values are estimated sound pressure levels at 3.3 ft. (1 m).

Top	97.7 dBa
Right side	98.3 dBa
Left side	99.6 dBa
Front	98.9 dBa
Exhaust	120.0 dBa

Fuel supply/drain system

Operating speed in RPM	1470		1760		1900		2100		2250	
CFP15E/EVS F10 fuel rate - gal/hr (L/hr)	19.9	(75)	22.5	(85)	23.6	(90)	24.7	(93)	19.6	(74)
CFP15E/EVS F20 fuel rate - gal/hr (L/hr)	21.4	(81)	24.1	(91)	25.4	(96)	26.5	(100)	21.1	(80)
CFP15E/EVS F30 fuel rate - gal/hr (L/hr)	23.5	(89)	26.5	(100)	27.9	(105)	29.1	(110)	23.1	(87)

Fuel type	No. 2 diesel only
Minimum supply line size	0.75 in. (19.05 mm)
Minimum drain line size	0.75 in. (19.05 mm)
Maximum fuel height above C/L fuel pump	105 in. (2.7 m)
Recommended fuel filter - primary	Cummins Filtration FS1041
Recommended fuel filter - secondary	None
Maximum restriction @ lift pump-inlet - with clean filter	6.0 in. Hg (152 mm Hg)
Maximum restriction @ lift pump-inlet - with dirty filter	10.0 in. Hg (254 mm Hg)
Maximum return line restriction - without check valves	9 in. Hg (229 mm Hg)
Minimum fuel tank vent capability	70 ft ³ /hr (2.1 m ³ /hr)
Maximum fuel temperature @ lift pump inlet	160 °F (71 °C)

Starting and electrical system

Minimum recommended battery capacity - cold soak at 0 °F (-18 °C) or above	24V
Engine only - cold cranking amperes	1400 CCA*
Engine only - reserve capacity	430 minutes*
*Based on FM requirement for a minimum of 900 CCA and 430 reserve capacity minutes	
Battery cable size - minimum of 2/0 AWG and maximum cable length not to exceed 6 ft. (1.5 m)	24V
Maximum resistance of starting circuit	0.002 Ohms
Typical cranking speed	100 RPM
Alternator (standard), internally regulated	70 amps

Operating conditions

Operating speed in RPM	1470		1760		1900		2100		2250	
CFP15E/EVS F-10										
Output - BHP (kW)	382	(285)	460	(343)	488	(364)	488	(364)	380	(283)
Ventilation air required - CFM (litre/sec)	970	(458)	1217	(574)	1357	(641)	1469	(693)	1542.5	(728)
Exhaust gas flow - CFM (litre/sec)	2500	(1180)	2881	(1360)	3099	(1463)	3308	(1561)	3473.4	(1639)
Exhaust gas temperature - °F (°C)	1025	(552)	1025	(552)	1025	(552)	1025	(552)	1025	(552)
Heat rejection to coolant - BTU/min. (kW)	6361	(112)	6947	(122)	7730	(136)	8085	(142)	8166	(143)
Heat rejection to ambient - BTU/min. (kW)	1423	(25)	1637	(29)	2064	(36)	1905	(33)	1886	(33)
CFP15E/EVS F-20										
Output - BHP (kW)	410	(306)	494	(369)	524	(391)	525	(392)	409	(305)
Ventilation air required - CFM (litre/sec)	1018	(480)	1258	(594)	1382	(652)	1515	(715)	1590.8	(751)
Exhaust gas flow - CFM (litre/sec)	2620	(1237)	2991	(1412)	3188	(1505)	3474	(1640)	3647.7	(1722)
Exhaust gas temperature - °F (°C)	1025	(552)	1025	(552)	1025	(552)	1025	(552)	1025	(552)
Heat rejection to coolant - BTU/min. (kW)	6683	(117)	7303	(128)	7954	(140)	8789	(154)	8877	(156)
Heat rejection to ambient - BTU/min. (kW)	1495	(26)	1721	(30)	2124	(37)	2071	(36)	2050	(36)
CFP15E/EVS F-30										
Output - BHP (kW)	450	(336)	536	(400)	575	(429)	564	(421)	418	(312)
Ventilation air required - CFM (litre/sec)	1063	(502)	1312	(619)	1405	(663)	1544	(729)	1621.2	(765)
Exhaust gas flow - CFM (litre/sec)	2740	(1293)	3164	(1493)	3328	(1571)	3577	(1688)	3755.9	(1773)
Exhaust gas temperature - °F (°C)	1025	(552)	1025	(552)	1025	(552)	1025	(552)	1025	(552)
Heat rejection to coolant - BTU/min. (kW)	7010	(123)	7849	(138)	8725	(153)	9111	(160)	9202	(162)
Heat rejection to ambient - BTU/min. (kW)	1568	(28)	1849	(32)	2330	(41)	2147	(38)	2125	(37)

CFP15E F70**Air induction system**

Maximum temperature rise between ambient air and engine air inlet	30 °F (16.7 °C)
Maximum inlet restriction with dirty filter	25 in. H ₂ O (635 mm H ₂ O)
Recommended air cleaner element - (standard)	K&N Serviceable/Disposable RC-3070
Recommended air cleaner element - (heavy duty)	Optional: primary element AF25544; secondary element AF25545

Lubrication system

Oil pressure range at rated	35-40 PSI (242-276 kPa)
Oil capacity of pan (high - low)	88-80 qt. (83-76 L)
Total system capacity	24 gal. (91 L)
Recommended lube oil filter	Cummins Filtration LF9000

Cooling system*

Raw water working pressure range at heat exchanger	60 PSI (413 kPa) MAX
Recommended minimum water supply pipe size to heat exchanger	1 in. (25.4 mm)
Recommended minimum water discharge pipe size from heat exchanger	1.25 in. (31.75 mm)
Coolant water capacity (engine only)	13.9 gal. (52.6 L)
Standard thermostat - type	Modulating
Standard thermostat - range	180-200 °F (82-93 °C)
Normal operating temperature	180-212 °F (82-100 °C)
Minimum raw water flow:	
- with water temperatures to 60 °F (16 °C)	33.6 GPM (2.12 L/sec)
- with water temperatures to 80 °F (27 °C)	35.2 GPM (2.22 L/sec)
- with water temperatures to 100 °F (38 °C)	36.8 GPM (2.32 L/sec)
Recommended cooling water filter	Cummins Filtration WF2073

* A jacket water heater is mandatory on this engine. The recommended heater wattage is 3000 down to 40 °F (4 °C)

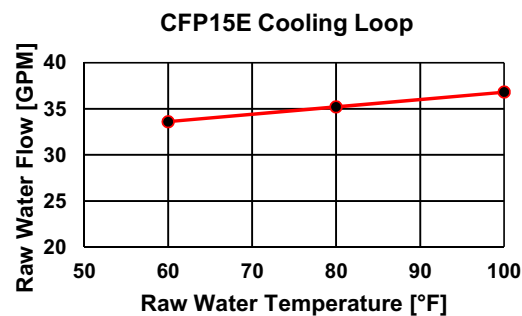

Exhaust system

Maximum allowable back pressure by complete exhaust system	40.8 in. H ₂ O (10.2 kPa)
Exhaust pipe size normally acceptable	6 in. (152 mm)

Noise emissions - The noise emission values are estimated sound pressure levels at 3.3 ft. (1 m).

Top	97.7 dBa
Right side	98.3 dBa
Left side	99.6 dBa
Front	98.9 dBa
Exhaust	120.0 dBa

Fuel supply/drain system

Operating speed in RPM	1760	
CFP15E F70 Fuel rate - gal/hr (L/hr)	35.9	(135.9)

Fuel type	No. 2 diesel only
Minimum supply line size	0.75 in. (19.05 mm)
Minimum drain line size	0.75 in. (19.05 mm)
Maximum fuel height above C/L fuel pump	105 in. (2.7 m)
Recommended fuel filter - primary	Cummins Filtration FS1041
Recommended fuel filter - secondary	None
Maximum restriction @ lift pump-inlet - with clean filter	6.0 in. Hg (152 mm Hg)
Maximum restriction @ lift pump-inlet - with dirty filter	10.0 in. Hg (254 mm Hg)
Maximum return line restriction - without check valves	6.5 in. Hg (165 mm Hg)
Minimum fuel tank vent capability	72 ft ³ /hr (2.16 m ³ /hr)
Maximum fuel temperature @ lift pump inlet	160 °F (71 °C)

Starting and electrical system

Minimum recommended battery capacity - cold soak at 0 °F (-18 °C) or above	24V
Engine only - cold cranking amperes	1400 CCA*
Engine only - reserve capacity	430 minutes*

*Based on FM requirement for a minimum of 900 CCA and 430 reserve capacity minutes

Battery cable size - minimum of 2/0 AWG and maximum cable length not to exceed 6 ft. (1.5 m)	24V
Maximum resistance of starting circuit	0.002 Ohms
Typical cranking speed	100 RPM
Alternator (standard), internally regulated	70 amps

Operating conditions

Operating speed in RPM	1760	
CFP15E/EVS F-70		
Output - BHP (kW)	686	(512)
Ventilation air required - CFM (litre/sec)	1380	(651)
Exhaust gas flow - CFM (litre/sec)	3200	(1510)
Exhaust gas temperature - °F (°C)	909	(488)
Heat rejection to coolant - BTU/min. (kW)	7830	(138)
Heat rejection to ambient - BTU/min. (kW)	2410	(42)

7.5 Cap screw markings and torque values



Always use a cap screw of the same measurement and strength as the cap screw being replaced. Using the wrong cap screws can result in engine damage.

Always use the torque values listed in the following tables when specific torque values are not available.



When the ft-lb value is less than 10, convert the ft-lb value to in-lb to obtain a better torque with an in-lb torque wrench. Example: 6 ft-lb equals 72 in-lb.

7.5.1 Cap screw identification

7.5.1.1 Metric cap screw identification and head markings

Sample:	M8-1.25 x 25		
Value:	M8	1.25	X 25
Meaning:	Major thread diameter in millimeters	Distance between threads in millimeters	Length in millimeters

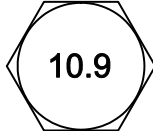
Metric cap screws and nuts are identified by the grade number stamped on the head of the cap screw or on the surface of the nuts.

Commercial Steel Class	8.8	10.9	12.9
Cap Screw Head Markings			

7.5.1.2 US customary cap screw identification and head markings

Sample:	5/16 x 18 x 1-1/2		
Value:	5/16	18	1-1/2
Meaning:	Major thread diameter in inches	Number of threads per inch	Length in inches

U.S. Customary cap screws are identified by radial lines stamped on the head of the cap screw.

SAE grade 5 w/three lines



SAE grade 8

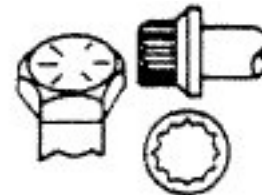

7.5.2 Cap screw torque values

Table 7-1. Metric Cap Screw Torque Values (lubricated threads)

Class:	8.8				10.9				12.9			
Diameter	Cast Iron		Aluminum		Cast Iron		Aluminum		Cast Iron		Aluminum	
mm	N•m	ft-lb	N•m	ft-lb	N•m	ft-lb	N•m	ft-lb	N•m	ft-lb	N•m	ft-lb
6	9	5	7	4	13	10	7	4	14	9	7	4
7	14	9	11	7	18	14	11	7	23	18	11	7
8	23	17	18	14	33	25	18	14	40	29	18	14
10	45	33	30	25	65	50	30	25	70	50	30	25
12	80	60	55	40	115	85	55	40	125	95	55	40
14	125	90	90	65	180	133	90	65	195	145	90	65
16	195	140	140	100	280	200	140	100	290	210	140	100
18	280	200	180	135	390	285	180	135	400	290	180	135
20	400	290	—	—	550	400	—	—	—	—	—	—

Table 7-2. U.S. Customary Cap Screw Torque Values (lubricated threads)

Grade:	SAE Grade 5				SAE Grade 8			
Cap Screw Body Size	Cast Iron		Aluminum		Cast Iron		Aluminum	
	N•m	ft-lb	N•m	ft-lb	N•m	ft-lb	N•m	ft-lb
1/4-20	9	7	8	6	15	11	8	6
1/4-28	12	9	9	7	18	13	9	7
5/16-18	20	15	16	12	30	22	16	12
5/16-24	23	17	19	14	33	24	19	14
3/8-16	40	30	25	20	55	40	25	20
3/8-24	40	30	35	25	60	45	35	25
7/16-14	60	45	45	35	90	65	45	35
7/16-20	65	50	55	40	95	70	55	40
1/2-13	95	70	75	55	130	95	75	55
1/2-20	100	75	80	60	150	110	80	60
9/16-12	135	100	110	80	190	140	110	80
9/16-18	150	110	115	85	210	155	115	85
5/8-11	180	135	150	110	255	190	150	110
5/8-18	210	155	160	120	290	215	160	120
3/4-10	325	240	255	190	460	340	255	190
3/4-16	365	270	285	210	515	380	285	210
7/8-9	490	360	380	280	745	550	380	280
7/8-14	530	390	420	310	825	610	420	310
1-8	720	530	570	420	1100	820	570	420
1-14	800	590	650	480	1200	890	650	480

7.6 CFP15E assembly drawings

Please refer to our website at cummins.com for the most up-to-date information.

Drawing No.	Description
A042J661	General Arrangement, Installation, Fire Pump, CFP15E F10/20/30
A042J662	General Arrangement, Installation, Fire Pump, CFP15E F70
A042H685	Assembly, Fire Pump, Industrial CFP15E/EVS F10-F30
A042H686	Assembly, Fire Pump, G-Drive CFP15E/EVS F70
8742	Assembly, Engine, Industrial, CFP15E F10-F30
11712	Assembly, Engine, G-Drive, CFP15E F70
11492-01	Assembly, Heat Exchanger CFP15E F10-F30, Raw Water
A042D121	Assembly, Heat Exchanger CFP15E F10-F30, Sea Water
11492-02	Assembly, Heat Exchanger CFP15E F70, Raw Water
17650	Assembly, Heat Exchanger CFP15E F70, Sea Water
10856-01	Assembly, Air Intake CFP15E/EVS F10-F30
10856-02	Assembly, Air Intake CFP15E/EVS F70
16707	Assembly, Guarding CFP15E/EVS
A042J191	Assembly, Coolant Heater CFP15E/EVS
A042H297	Assembly, Sensors and Harnessing CFP15E/EVS
A042J761	Assembly, Secondary ECM CFP15E/EVS
21249	Assembly, Control Panel Mounting
Assembly, All Components Top-level:	
A042G185	Assembly, Panel, Digital Electronic
8824-24	Battery Contactors 24V
A042J765	Kit, Fuel Lines CFP15E/EVS
18501	Kit, Fuel Valve Bypass
A042A257	Misc. Piping, Cooling Loop, Raw Water CFP15E/EVS
A042H730	Assembly, Raw Water Cooling Loop, 1" Vertical
A042H732	Assembly, Raw Water Cooling Loop, 1" Horizontal 24V
A042C201	Misc. Piping, Cooling Loop, Sea Water CFP15E/EVS
A042H733	Assembly, Sea Water Cooling Loop, 1" Vertical
A042H735	Assembly, Sea Water Cooling Loop, 1" Horizontal 24V
12590	Assembly, Stub-Shaft and Guarding CFP15E/EVS
A042J125	Schematic, Overall CFP15E/EVS, GEN II FPDP
A042E428	Assembly, VSPLC (FM-approved option)

LEGEND AND DATUM IDENTIFIER	
SHEET 1	INSTALLATION DRAWING
SHEET 2	GENERAL ARRANGEMENT - HORIZONTAL SPLIT CASE PUMP BASE OPTION
SHEET 3	GENERAL ARRANGEMENT - VERTICAL TURBINE PUMP BASE OPTION
SHEET 4	DRIVE LINE OPTIONS
SHEET 5	ELECTRICAL INFORMATION
DATUM "A"	FACE OF FLYWHEEL HOUSING
DATUM "B"	REAR LEG BOLT LOCATION
DATUM "C"	FLYWHEEL MOUNTING SURFACE
DATUM "D"	UJOINT ADAPTER MOUNTING SURFACE
DATUM "EOS"	END OF PUMP SHAFT

CFP15E CONNECTION INFORMATION	
SAE #1	FLYWHEEL HOUSING
3/4" NPT	FUEL INLET
3/4" NPT	FUEL OUTLET
1" NPT	RAW WATER INLET
1 1/4" NPT	RAW WATER DISCHARGE
120 / 240 VAC	COOLANT HEATER (3000 WATTS)
6" DIA NPT, CUFF, OR FLANGE	EXHAUST CONNECTION
1/2" NPT	VSPLC CONNECTION

REV	REL NO	REVISION	DWN	CKD	APVD	DATE
0	2016-668	INITIAL RELEASE	HE392	-	-	12JAN17
1	2020-021	ADDED CG DIMENSIONS & NOTES; REMOVED CFP15E-F40 SPECS; REPLACED ECM & WIRE HARNESS; UPDATED FUEL LINE KIT	NO134	MS707	MS707	31JAN20

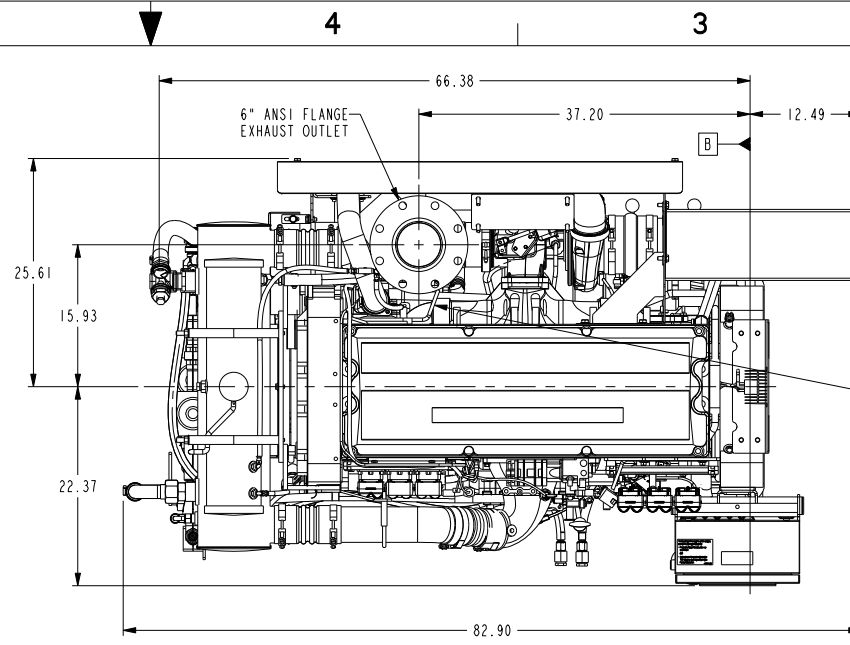

ENGINE ONLY LIFTING POINTS

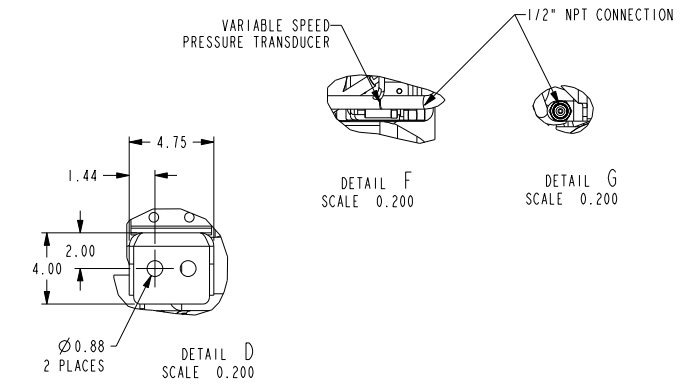
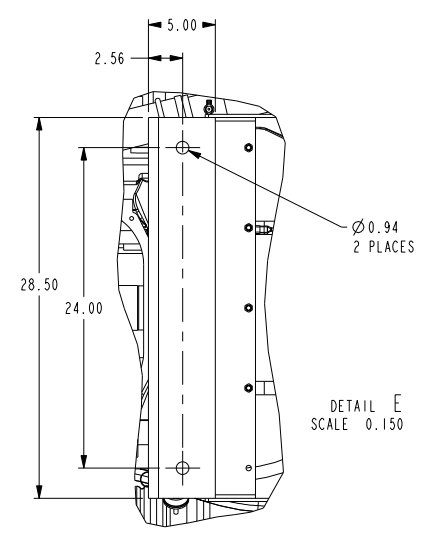
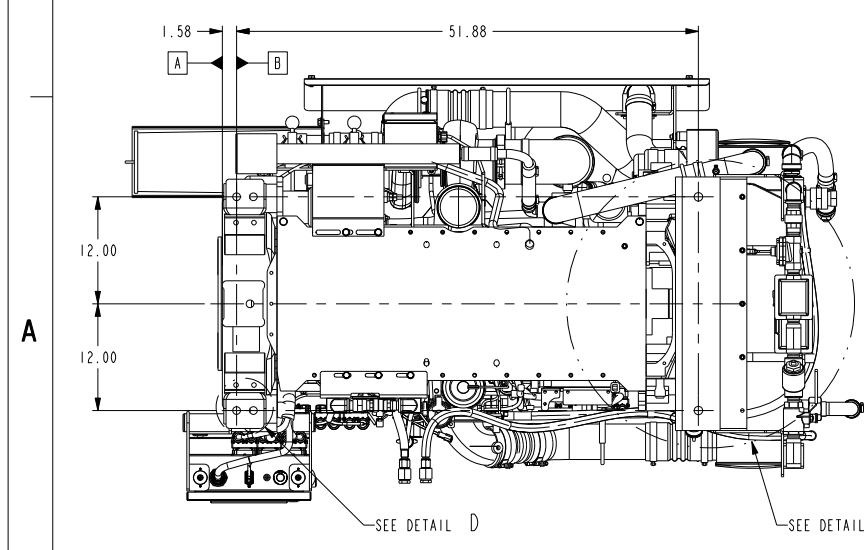
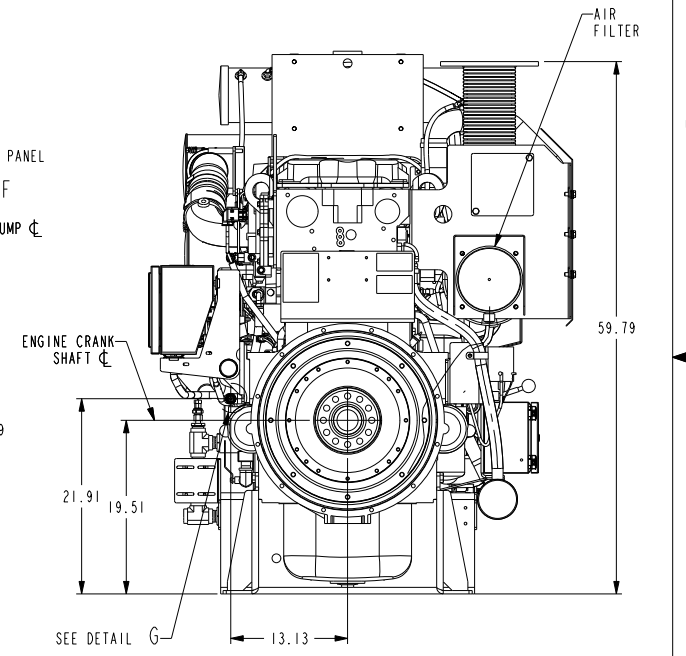
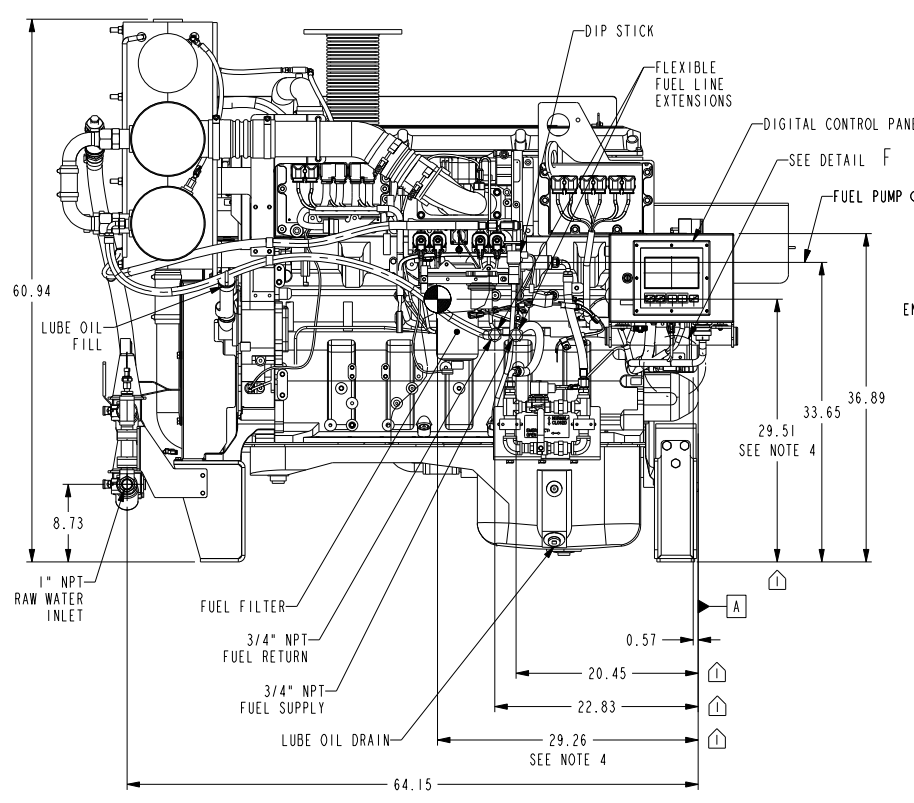
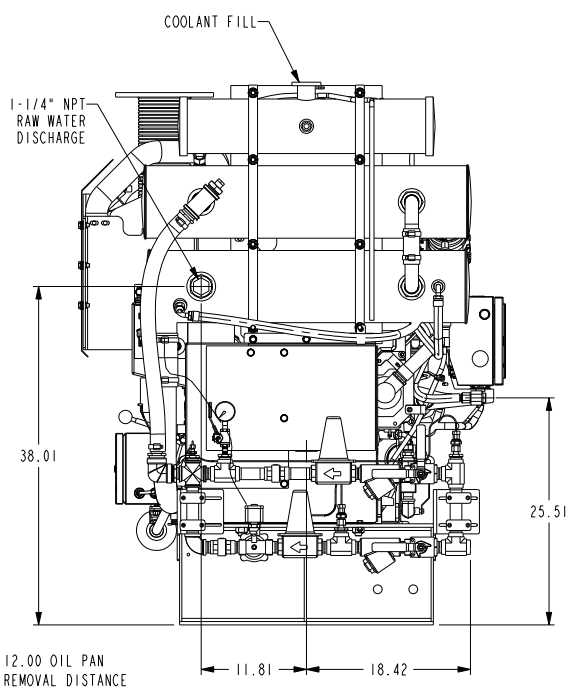
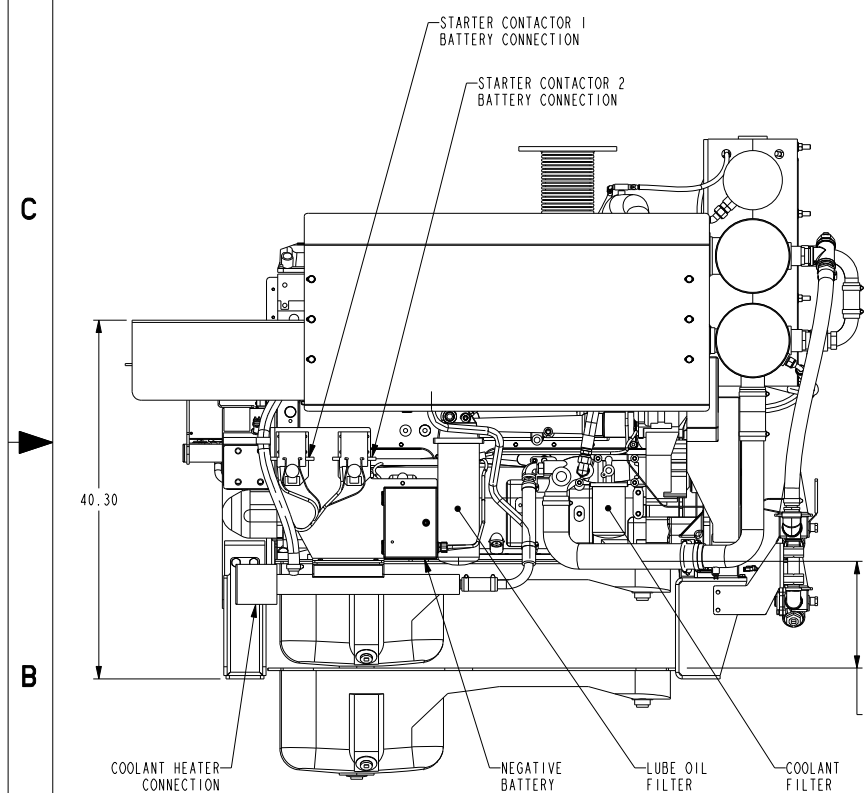

- NOTES:
- ALL PLUMBING MUST BE SUPPORTED AND/OR ISOLATED SO THAT NO WEIGHT OR STRESS IS APPLIED TO ANY ENGINE COMPONENT
 - REFER TO ENGINE DATA SHEET FOR CUSTOMER CONNECTION RECOMMENDATIONS
 - DRAWING SUBJECT TO CHANGE WITH OUT NOTICE
 - CENTER OF GRAVITY LOCATION IS APPROXIMATE

DIMENSIONS ARE IN: INCHES 1. ARE IN: DRAWING TOLERANCES APPLY TO PRIMARY DIMENSIONS UNLESS OTHERWISE SPECIFIED X.1: ± 1/16 IN OR 0.6 mm X.2: ± 1/32 IN OR 0.8 mm X.3: ± 0.01 IN OR 0.25 mm X.4: ± 0.005 IN OR 0.125 mm ANGULAR TOLERANCE: ±	DO NOT SCALE PRINT SCALE 0.100	CMV DATA CLASSIFICATION Cummins Confidential DWN: HE392 CKD: - APVD: - DATE: 12JAN2017	Cummins Inc. ITEM NAME GENERAL ARRANGEMENT CFP15E-F10/20/30 CAD SHEET 1 OF 5 ITEM NUMBER A042J661	REV 1
---	-----------------------------------	---	--	----------

8 7 6 5 4 3 2 1

LEGEND AND DATUM IDENTIFIER	
SHEET 1	INSTALLATION DRAWING
SHEET 2	GENERAL ARRANGEMENT - HORIZONTAL SPLIT CASE PUMP BASE OPTION
SHEET 3	GENERAL ARRANGEMENT - VERTICAL TURBINE PUMP BASE OPTION
SHEET 4	DRIVE LINE OPTIONS
SHEET 5	ELECTRICAL INFORMATION
DATUM "A"	FACE OF FLYWHEEL HOUSING
DATUM "B"	REAR LEG BOLT LOCATION
DATUM "C"	FLYWHEEL MOUNTING SURFACE
DATUM "D"	UJOINT ADAPTER MOUNTING SURFACE
DATUM "EOS"	END OF PUMP SHAFT

REV	REL NO	REVISION	DWN	CKD	APVD	DATE
0	2016-668	INITIAL RELEASE	HE392	-	-	12JAN17
1	2020-021	SEE SHEET 1 FOR REVISION DETAILS	NO134	MS707	MS707	31JAN20

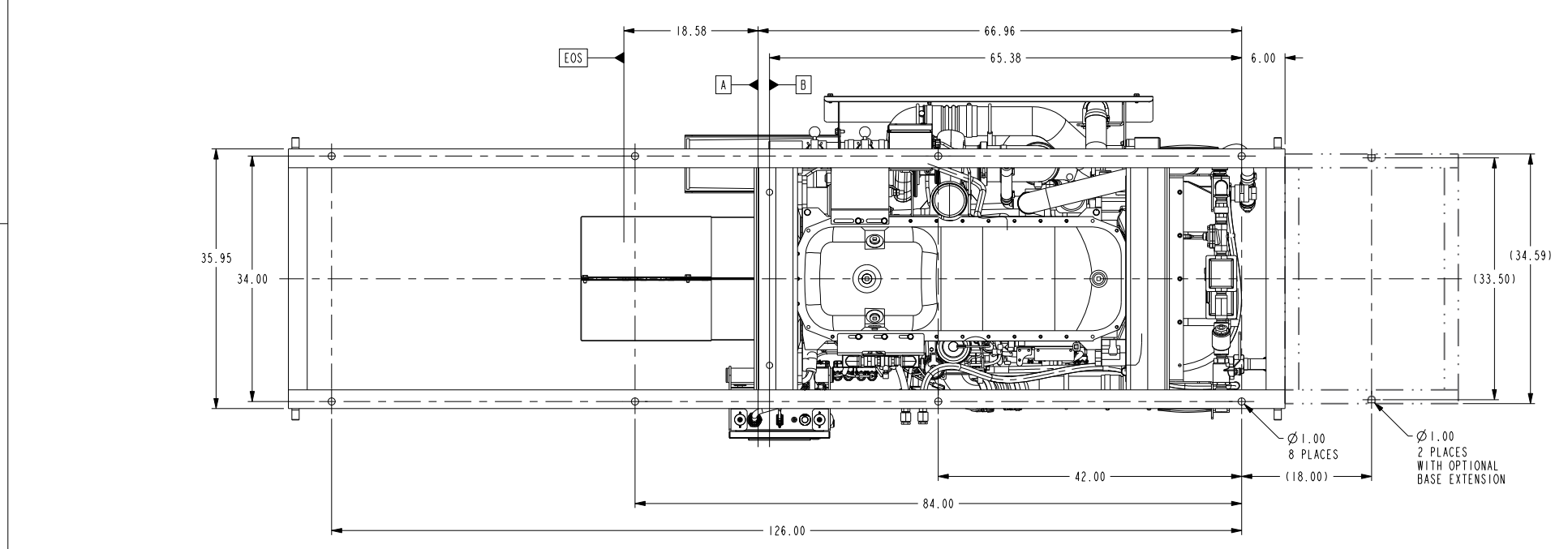
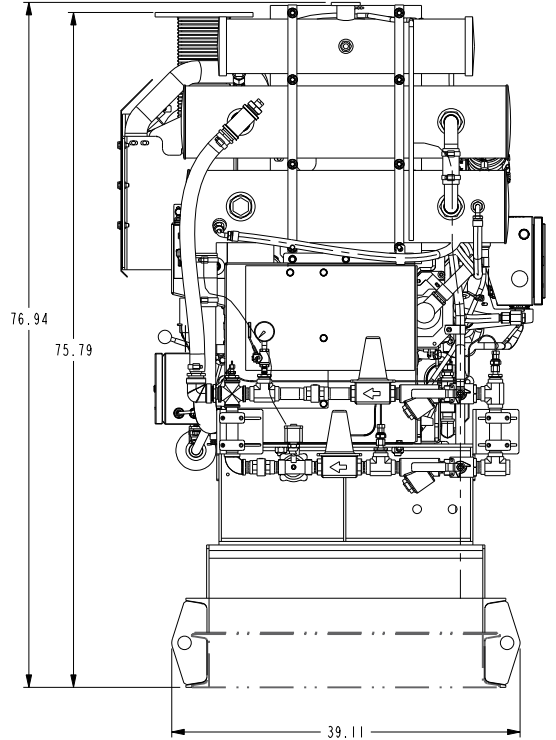
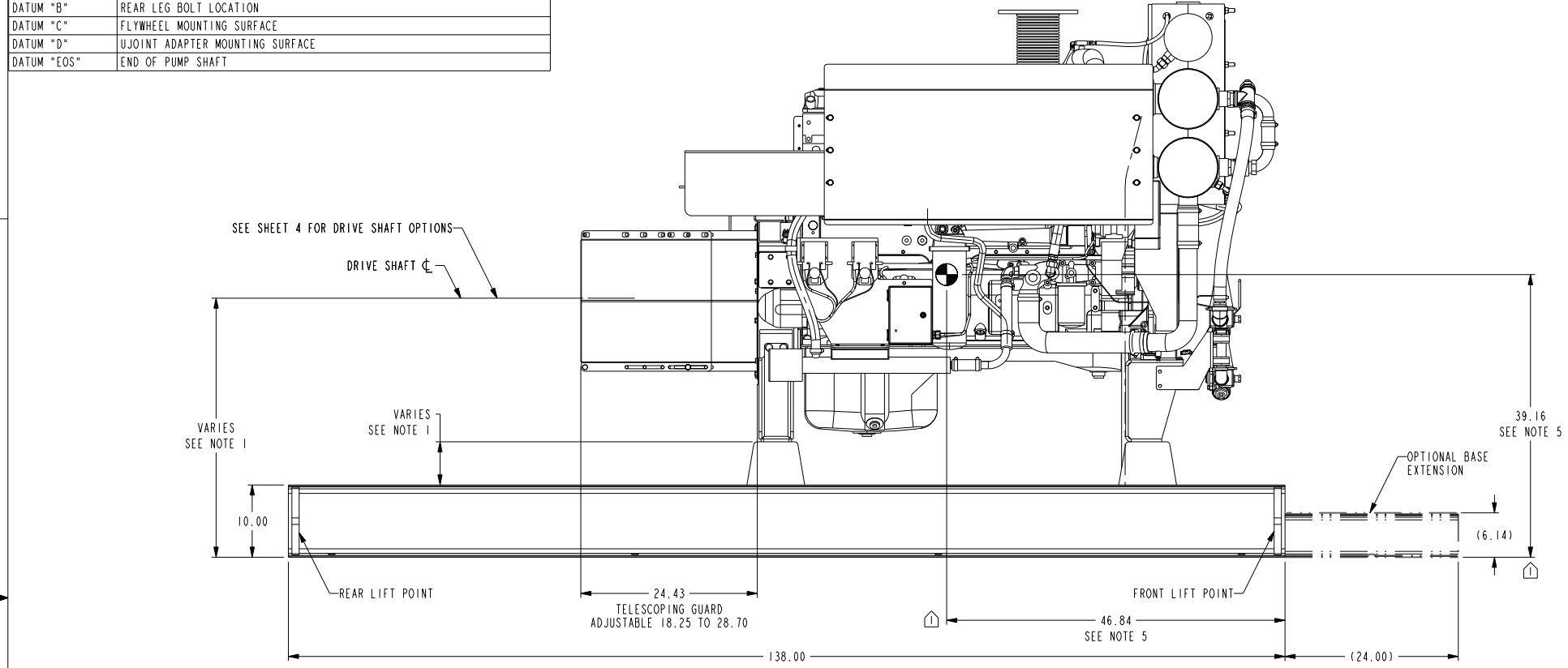

- NOTES:
1. RISER HEIGHT VARIES TO ACCOMMODATE CUSTOMER SUPPLIED PUMPS
 2. REFERENCE OWNERS MANUAL FOR DRIVE SHAFT ALIGNMENT SPECS
 3. DRAWING SUBJECT TO CHANGE WITHOUT NOTICE
 4. REFERENCE SHEET 1 FOR BASE FIRE PUMP INTERFACE
 5. CENTER OF GRAVITY LOCATION IS APPROXIMATE & DOES NOT INCLUDE U-JOINT ADAPTER, DRIVE SHAFT, COMPANION FLANGE, DRIVE SHAFT GUARDS OR BASE EXTENSION

<small>DIMENSIONS ARE IN: INCHES 1. ARE IN: DRAWING TOLERANCES APPLY TO PRIMARY DIMENSIONS UNLESS OTHERWISE SPECIFIED</small>	<small>DO NOT SCALE PRINT</small> SCALE 0.100	<small>CMI DATA CLASSIFICATION</small> Cummins Confidential		Cummins Inc.	
				ITEM NAME GENERAL ARRANGEMENT CFP15E-F10/20/30	
<small>THIS DOCUMENT (AND THE INFORMATION SHOWN THEREIN) IS CONFIDENTIAL AND PROPRIETARY AND SHALL NOT BE DISCLOSED TO OTHERS IN ANY FORM OR BY ANY MEANS, OR REPRODUCED IN ANY MANNER, WITHOUT THE WRITTEN CONSENT OF CUMMINS INC.</small>	<small>FOR INTERPRETATION OF DIMENSIONING AND TOLERANCING, SEE ASME Y14.5-2009</small>	<small>MUST CONFORM TO CES 10903</small>	<small>CAD SHEET</small> 2 OF 5	<small>ITEM NUMBER</small> A042J661	<small>REV</small> 1

8 7 6 5 4 3 2 1

LEGEND AND DATUM IDENTIFIER	
SHEET 1	INSTALLATION DRAWING
SHEET 2	GENERAL ARRANGEMENT - HORIZONTAL SPLIT CASE PUMP BASE OPTION
SHEET 3	GENERAL ARRANGEMENT - VERTICAL TURBINE PUMP BASE OPTION
SHEET 4	DRIVE LINE OPTIONS
SHEET 5	ELECTRICAL INFORMATION
DATUM "A"	FACE OF FLYWHEEL HOUSING
DATUM "B"	REAR LEG BOLT LOCATION
DATUM "C"	FLYWHEEL MOUNTING SURFACE
DATUM "D"	UJOINT ADAPTER MOUNTING SURFACE
DATUM "EOS"	END OF PUMP SHAFT

REV	REL NO	REVISION	DWN	CKD	APVD	DATE
0	2016-668	INITIAL RELEASE	HE392	-	-	12JAN17
1	2020-021	SEE SHEET 1 FOR REVISION DETAILS	NO134	MS707	MS707	31JAN20

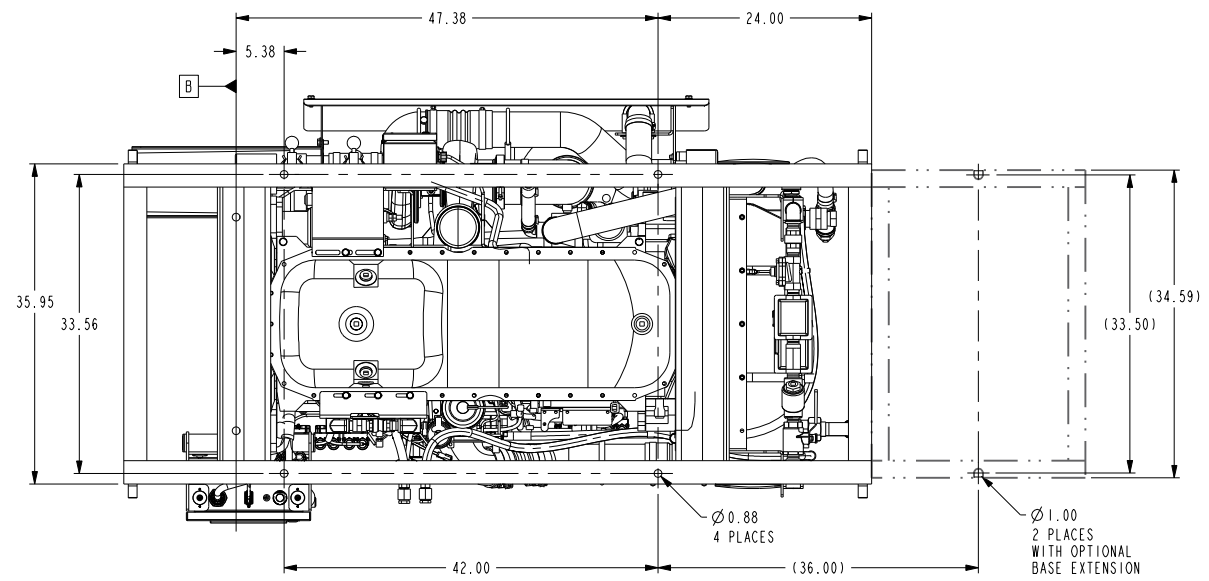
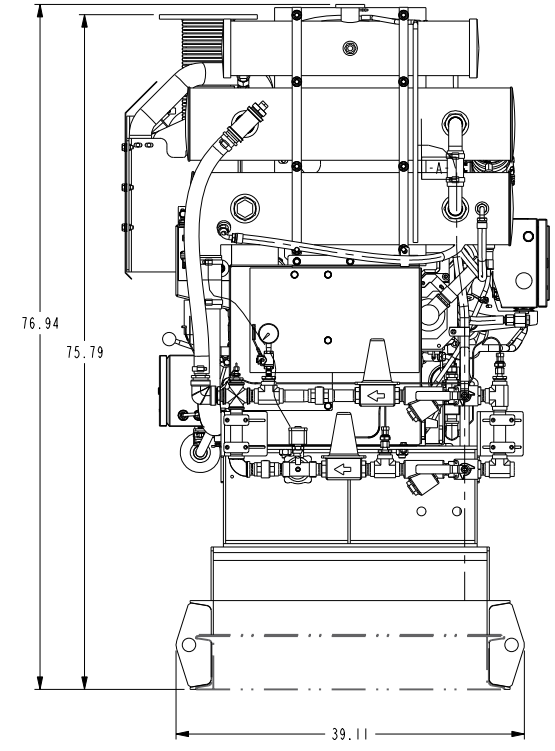
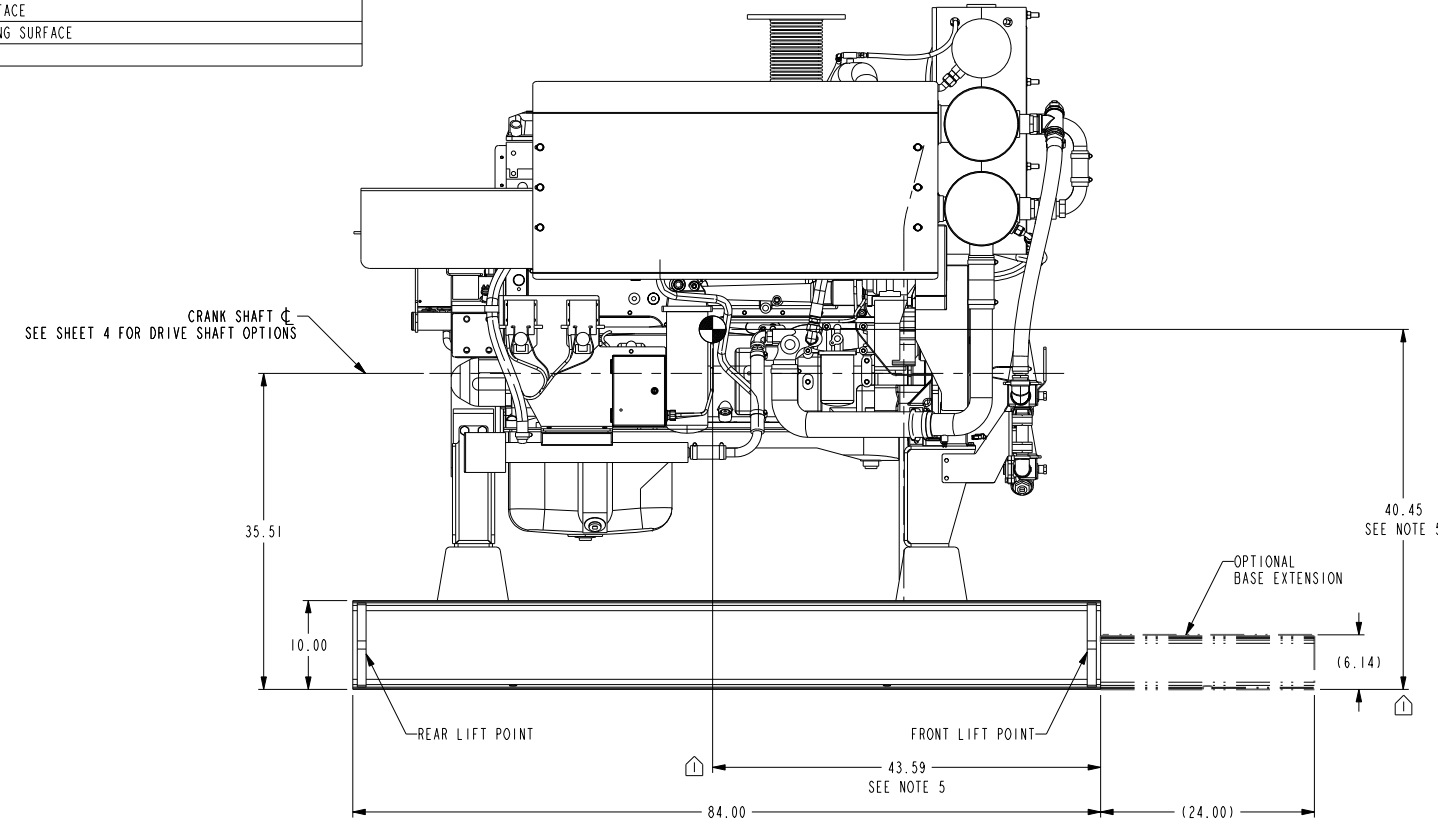

NOTE:
 1. TORSIONAL ANALYSIS REQUIRED FOR VERTICAL TURBINE INSTALLATION
 2. REFERENCE OWNERS MANUAL FOR DRIVE SHAFT ALIGNMENT SPECS
 3. DRAWING SUBJECT TO CHANGE WITHOUT NOTICE
 4. REFERENCE SHEET 1 FOR BASE FIRE PUMP INTERFACE
 5. CENTER OF GRAVITY LOCATION IS APPROXIMATE & DOES NOT INCLUDE BASE EXTENSION

DIMENSIONS ARE IN: INCHES 1.1 ARE IN:	DO NOT SCALE PRINT	CMI DATA CLASSIFICATION Cummins Confidential		Cummins Inc.	
DRAWING TOLERANCES APPLY TO PRIMARY DIMENSIONS UNLESS OTHERWISE SPECIFIED F: ± 0.004 IN OR 0.10 mm M: ± 0.003 IN OR 0.075 mm H: ± 0.002 IN OR 0.05 mm L: ± 0.001 IN OR 0.025 mm ANGULAR TOLERANCE: ± 0.005°	SCALE 0.100	DWN: HE392 CKD: - APVD: - DATE: 12JAN2017		ITEM NAME GENERAL ARRANGEMENT CFP15E-F10/20/30	CAD SHEET 3 OF 5
THIS DOCUMENT (AND THE INFORMATION SHOWN THEREON) IS CONFIDENTIAL AND PROPRIETARY AND SHALL NOT BE DISCLOSED TO OTHERS IN HARD COPY OR ELECTRONIC FORM, REPRODUCED BY ANY MEANS, OR USED FOR ANY PURPOSE WITHOUT WRITTEN CONSENT OF CUMMINS INC.			FOR INTERPRETATION OF DIMENSIONING AND TOLERANCING, SEE ASME Y14.5-2009	MUST CONFORM TO CES 10903	REV 1

LEGEND AND DATUM IDENTIFIER	
SHEET 1	INSTALLATION DRAWING
SHEET 2	GENERAL ARRANGEMENT - HORIZONTAL SPLIT CASE PUMP BASE OPTION
SHEET 3	GENERAL ARRANGEMENT - VERTICAL TURBINE PUMP BASE OPTION
SHEET 4	DRIVE LINE OPTIONS
SHEET 5	ELECTRICAL INFORMATION
DATUM "A"	FACE OF FLYWHEEL HOUSING
DATUM "B"	REAR LEG BOLT LOCATION
DATUM "C"	FLYWHEEL MOUNTING SURFACE
DATUM "D"	UJOINT ADAPTER MOUNTING SURFACE
DATUM "EOS"	END OF PUMP SHAFT

ENGINE MODEL	CFP DRIVE SHAFT MATRIX				
	CFP F RATINGS WITH MULTIPLE SHAFTS				
	RPM 1470	RPM 1760	RPM 1900	RPM 2100	RPM 2250
CFP15E-F10	3172 SHAFT	3172 SHAFT	NON LISTED 3172 SHAFT	NON LISTED 3172 SHAFT	NON LISTED 3172 SHAFT
CFP15E-F20	3172 SHAFT	NON LISTED 3172 SHAFT	NON LISTED 3172 SHAFT	NON LISTED 3172 SHAFT	NON LISTED 3172 SHAFT
CFP15E-F30	NON LISTED 3172 SHAFT	NON LISTED 3172 SHAFT	NON LISTED 3172 SHAFT	NON LISTED 3172 SHAFT	NON LISTED 3172 SHAFT

REV	REL NO	REVISION	DWN	CKD	APVD	DATE
0	2016-668	INITIAL RELEASE	HE392	-	-	12JAN17
1	2020-021	SEE SHEET 1 FOR REVISION DETAILS	NO134	MS707	MS707	31JAN20

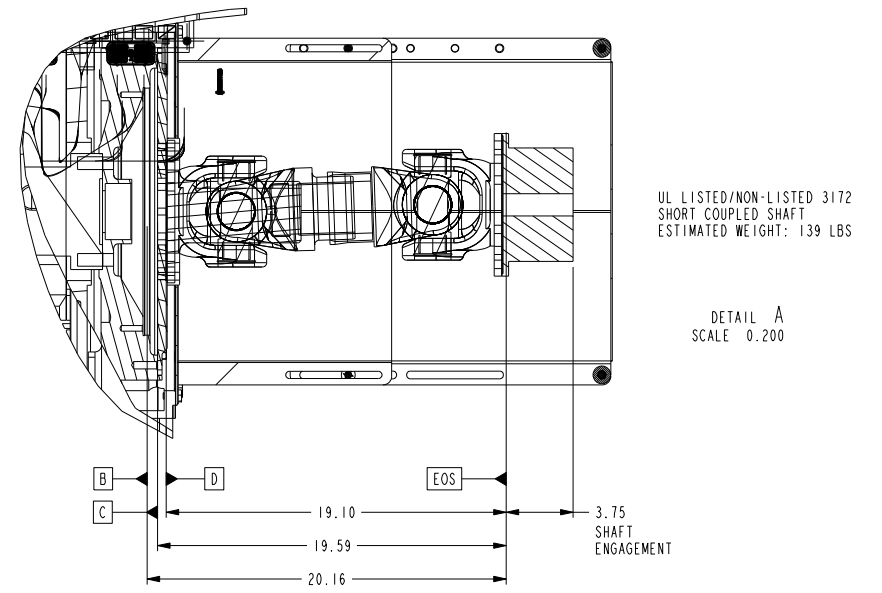
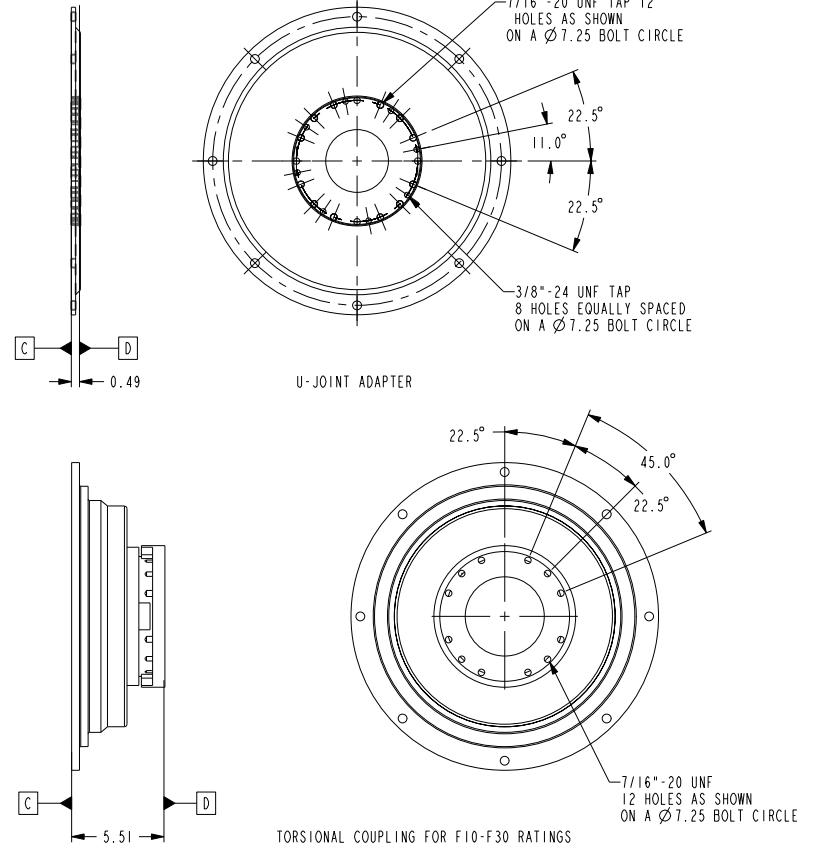
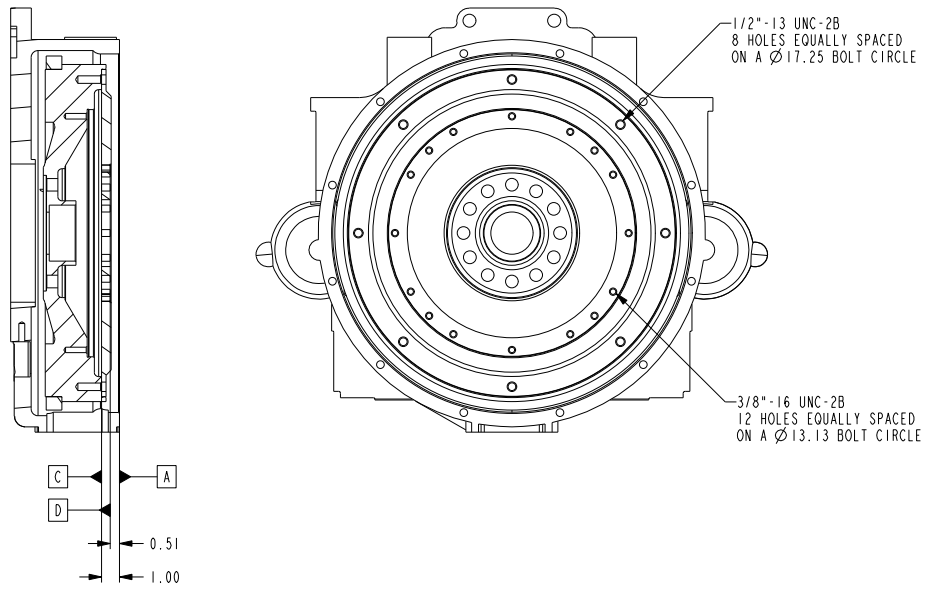
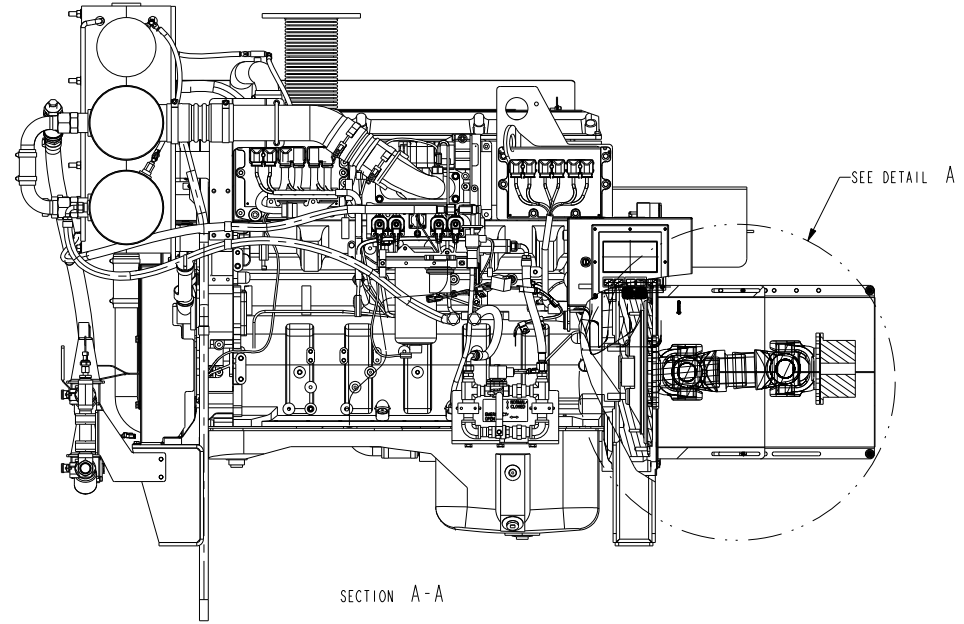
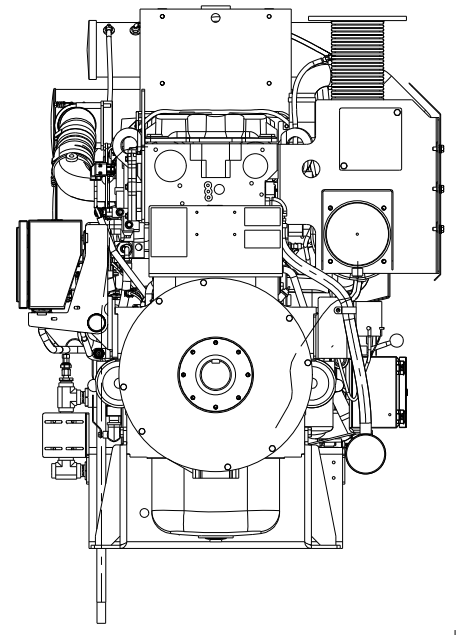
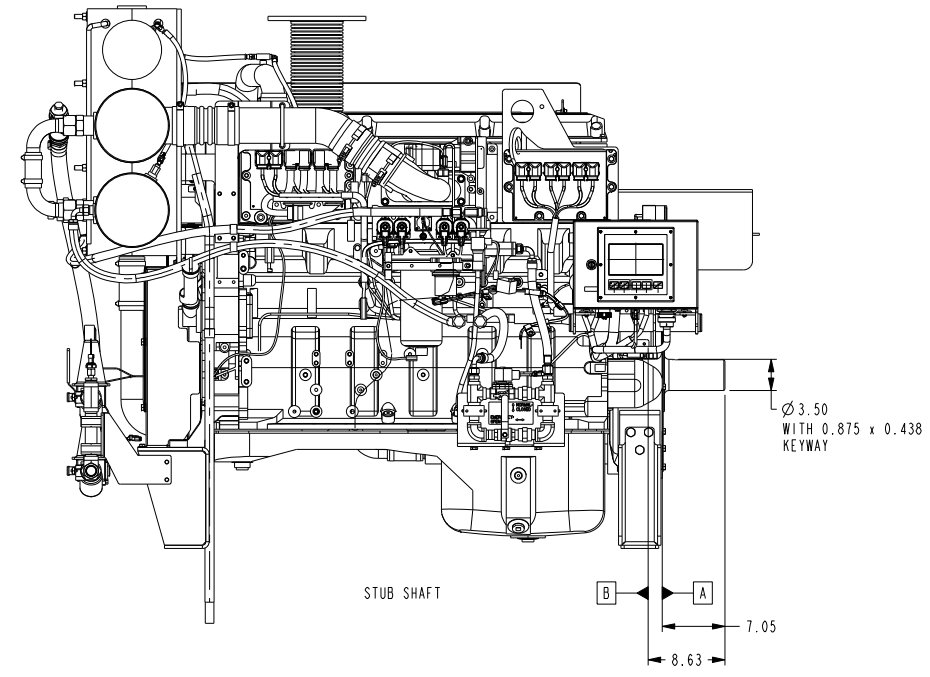

NOTE:

- TORSIONAL ANALYSIS REQUIRED FOR VERTICAL TURBINE INSTALLATION
- REFERENCE OWNERS MANUAL FOR DRIVE SHAFT ALIGNMENT SPECS
- DRAWING SUBJECT TO CHANGE WITHOUT NOTICE
- REFERENCE SHEET 1 FOR BASE FIRE PUMP INTERFACE

DIMENSIONS ARE IN: INCHES 1 J ARE IN:	DO NOT SCALE PRINT	CMI DATA CLASSIFICATION Cummins Confidential	Cummins Inc.
DRAWING TOLERANCES APPLY TO PRIMARY DIMENSIONS UNLESS OTHERWISE SPECIFIED	SCALE 0.100	DWN: HE392	
THIS DOCUMENT (AND THE INFORMATION SHOWN THEREIN) IS CONFIDENTIAL AND PROPRIETARY AND SHALL NOT BE DISCLOSED TO OTHERS IN HARD COPY OR ELECTRONIC FORM, REPRODUCED BY ANY MEANS, OR USED FOR ANY PURPOSE WITHOUT WRITTEN CONSENT OF CUMMINS INC.	FOR INTERPRETATION OF DIMENSIONING AND TOLERANCING, SEE ASME Y14.5-2009	MUST CONFORM TO CES 10903	ITEM NAME GENERAL ARRANGEMENT CFP15E-F10/20/30
			CAD SHEET 4 OF 5
			ITEM NUMBER A042J661
			REV 1

8

7

6

5

4

3

2

1

REV	REL NO	REVISION	DWN	CKD	APVD	DATE
0	2016-668	INITIAL RELEASE	HE392	-	-	12JAN17
1	2020-021	SEE SHEET 1 FOR REVISION DETAILS	NO134	MS707	MS707	31JAN20

LEGEND AND DATUM IDENTIFIER	
SHEET 1	INSTALLATION DRAWING
SHEET 2	GENERAL ARRANGEMENT - HORIZONTAL SPLIT CASE PUMP BASE OPTION
SHEET 3	GENERAL ARRANGEMENT - VERTICAL TURBINE PUMP BASE OPTION
SHEET 4	DRIVE LINE OPTIONS
SHEET 5	ELECTRICAL INFORMATION
DATUM "A"	FACE OF FLYWHEEL HOUSING
DATUM "B"	REAR LEG BOLT LOCATION
DATUM "C"	FLYWHEEL MOUNTING SURFACE
DATUM "D"	UJOINT ADAPTER MOUNTING SURFACE
DATUM "EOS"	END OF PUMP SHAFT

D

D

C

C

B

B

A

A

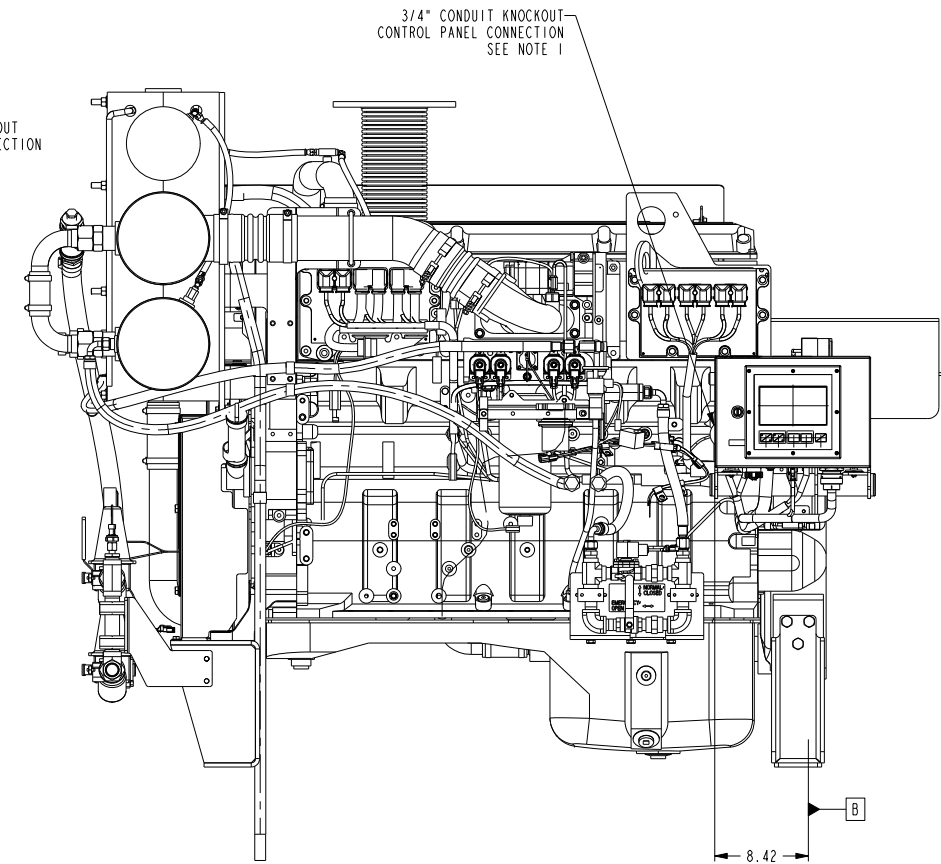
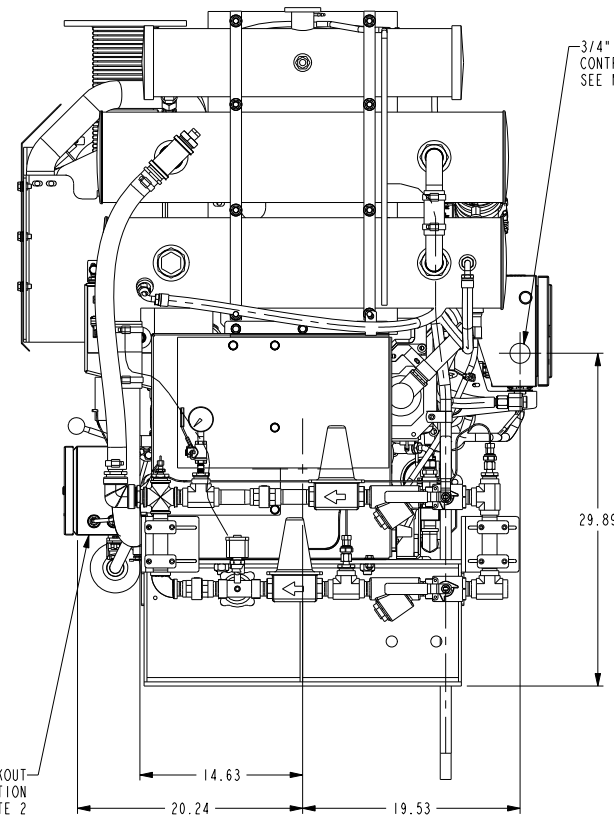
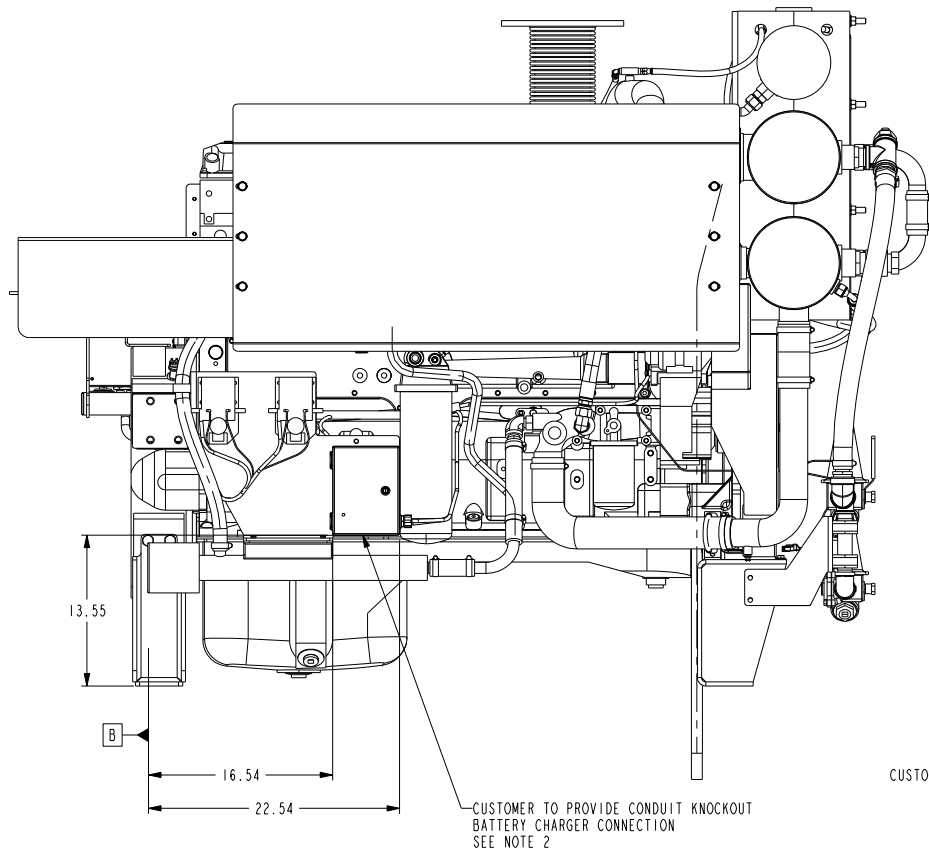

- NOTES:
- CONTROL PANEL TERMINAL BLOCKS
1, 2, 3, 4, 5, 9, 10, 301, 302, 303, 304, 310, 311, 312
 - BATTERY CHARGER CONNECTION BOX TERMINAL BLOCKS
6, 8, 11

DIMENSIONS ARE IN: INCHES [] ARE IN: []	DO NOT SCALE PRINT SCALE 0.125	CMI DATA CLASSIFICATION Cummins Confidential		Cummins Inc.	
DRAWING TOLERANCES APPLY TO PRIMARY DIMENSIONS UNLESS OTHERWISE SPECIFIED X: ± 0.005 IN OR 0.127 mm Y: ± 0.003 IN OR 0.076 mm Z: ± 0.002 IN OR 0.051 mm ANGULAR TOLERANCE: ± 0.005		DWN: HE392 CKD: - APVD: - DATE: 12JAN2017		ITEM NAME GENERAL ARRANGEMENT CFP15E-F10/20/30	CAD SHEET 5 OF 5
THIS DOCUMENT (AND THE INFORMATION SHOWN THEREIN) IS CONFIDENTIAL AND PROPRIETARY AND SHALL NOT BE DISCLOSED TO OTHERS IN HAND COPY OR ELECTRONIC FORM, REPRODUCED BY ANY MEANS, OR USED FOR ANY PURPOSE WITHOUT WRITTEN CONSENT OF CUMMINS INC.			FOR INTERPRETATION OF DIMENSIONING AND TOLERANCING, SEE ASME Y14.5-2009	MUST CONFORM TO CES 10903	REV 1

8

7

6

5

4

3

2

1

LEGEND AND DATUM IDENTIFIER	
SHEET 1	INSTALLATION DRAWING
SHEET 2	GENERAL ARRANGEMENT - HORIZONTAL SPLIT CASE PUMP BASE OPTION
SHEET 3	GENERAL ARRANGEMENT - VERTICAL TURBINE PUMP BASE OPTION
SHEET 4	DRIVE LINE OPTIONS
SHEET 5	ELECTRICAL INFORMATION
DATUM "A"	FACE OF FLYWHEEL HOUSING
DATUM "B"	REAR LEG BOLT LOCATION
DATUM "C"	FLYWHEEL MOUNTING SURFACE
DATUM "D"	UJOINT ADAPTER MOUNTING SURFACE
DATUM "EOS"	END OF PUMP SHAFT

CFPI5E CONNECTION INFORMATION	
SAE #1	FLYWHEEL HOUSING
3/4" NPT	FUEL INLET
3/4" NPT	FUEL OUTLET
1" NPT	RAW WATER INLET
1 1/4" NPT	RAW WATER DISCHARGE
120 / 240 VAC	COOLANT HEATER (3000WATTS)
6" DIA NPT, CUFF, OR FLANGE	EXHAUST CONNECTION

REV	REL NO	REVISION	DWN	CKD	APVD	DATE
-	2016-668	RELEASED TO PRODUCTION	HE392	NE627	NE627	16JAN17
A	2019-211	REPLACED EXHAUST TUBE WAS 13572	NO134	MS707	MS707	21MAY19
2	2020-021	ADDED CG DIMENSIONS & NOTES; REPLACED ECM & FUEL LINE KIT	NO134	MS707	MS707	03FEB20

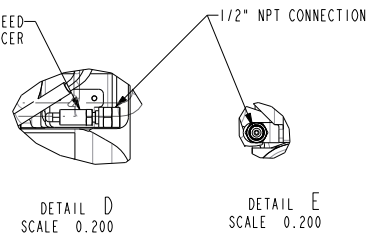
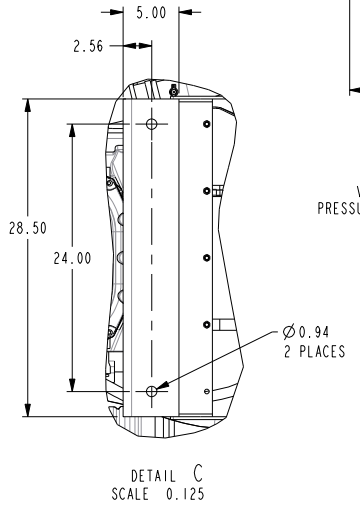
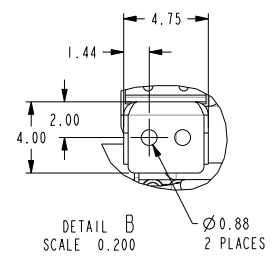
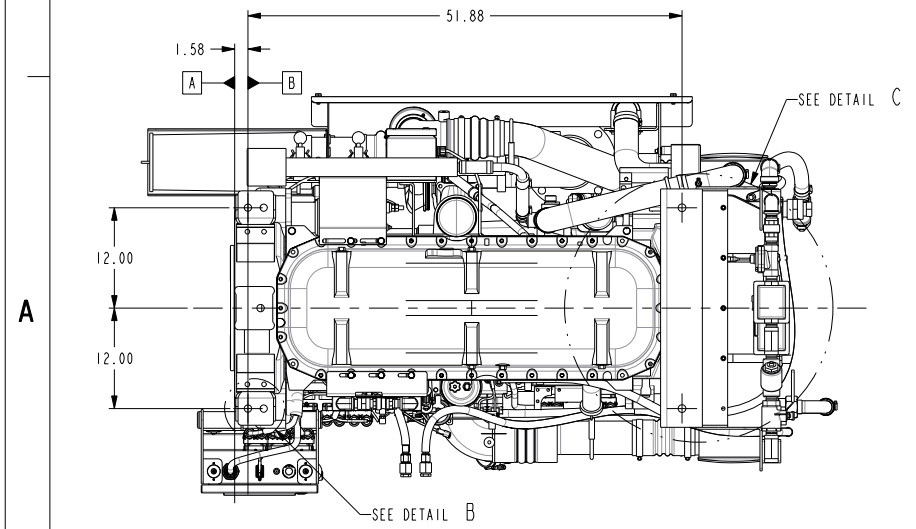
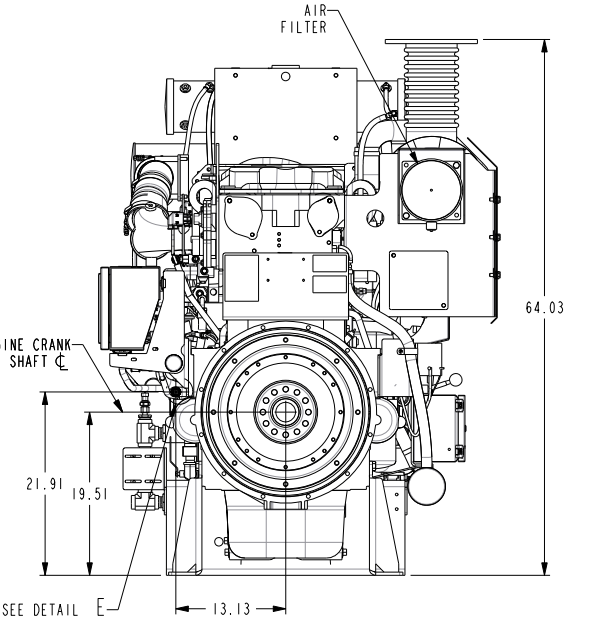
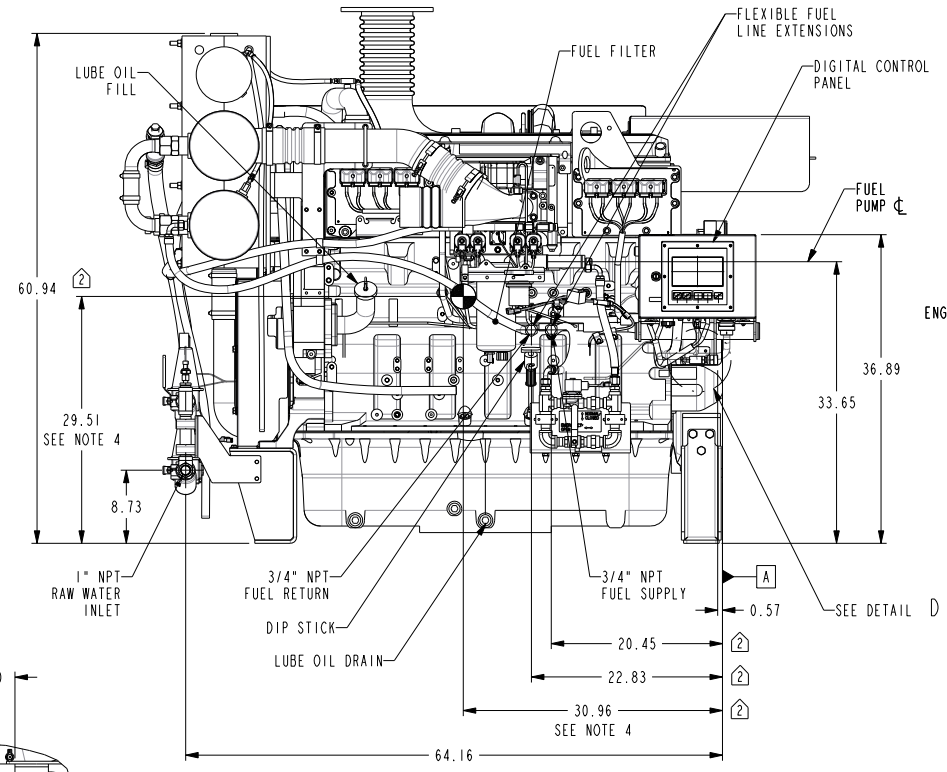
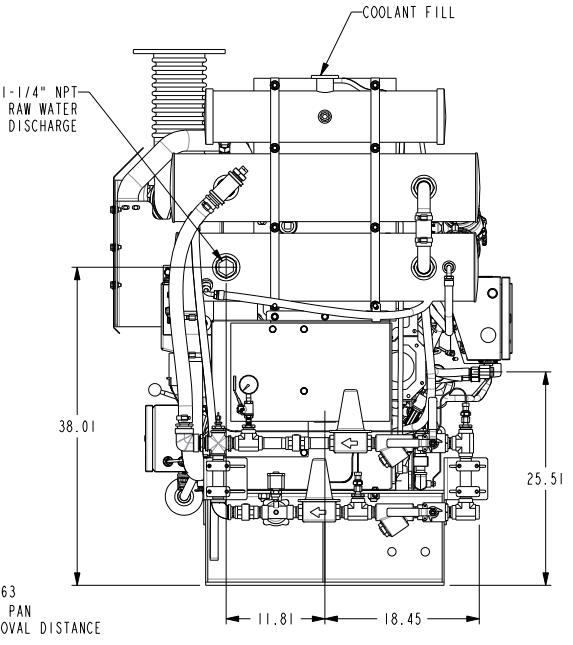
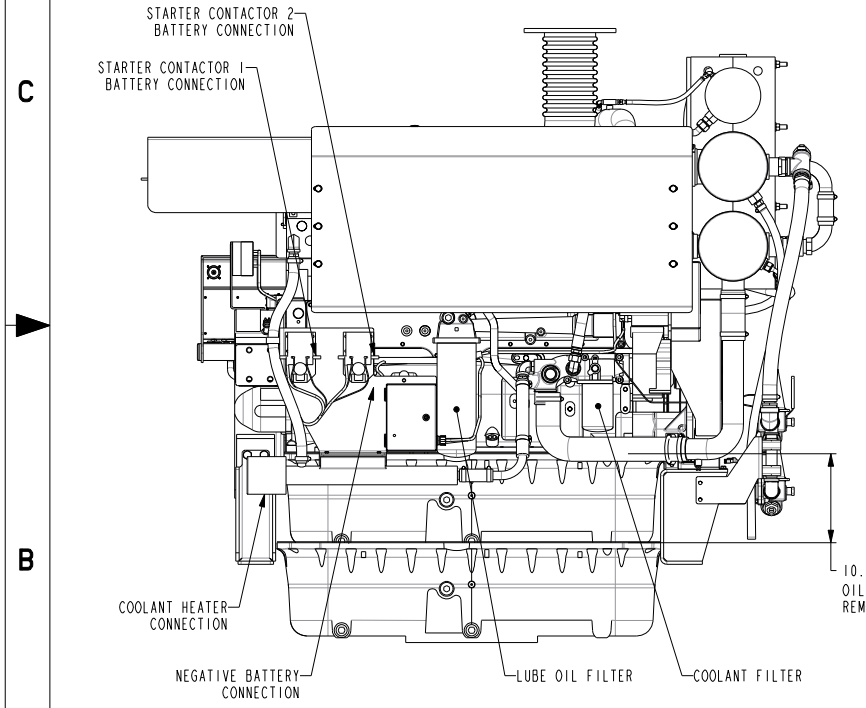
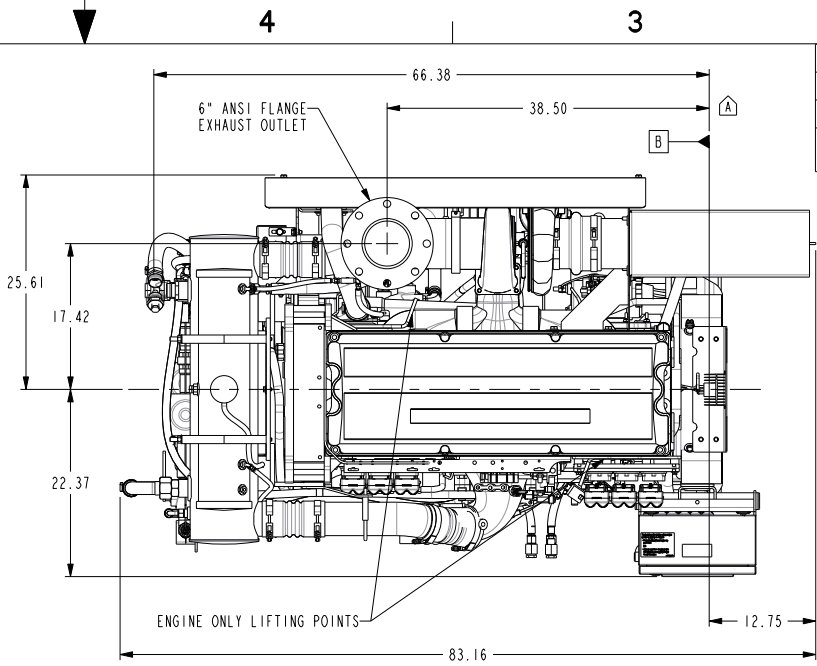

- NOTES:
- ALL PLUMBING MUST BE SUPPORTED AND/OR ISOLATED SO THAT NO WEIGHT OR STRESS IS APPLIED TO ANY ENGINE COMPONENT
 - REFER TO ENGINE DATA SHEET FOR CUSTOMER CONNECTION RECOMMENDATIONS
 - DRAWING SUBJECT TO CHANGE WITH OUT NOTICE
 - CENTER OF GRAVITY LOCATION IS APPROXIMATE

DIMENSIONS ARE IN: INCHES 1.1 ARE IN: DRAWING TOLERANCES APPLY TO PRIMARY DIMENSIONS UNLESS OTHERWISE SPECIFIED X: ± 1 IN OR 4 mm X.X: ± 1 IN OR 0.1 mm X.XX: ± 0.00 IN OR 0.25 mm X.XXX: ± 0.01 IN OR 0.25 mm ANGULAR TOLERANCES: ±	DO NOT SCALE PRINT SCALE 0.094	CMI DATA CLASSIFICATION Cummins Confidential DWN HE392 CKD NE627 APVD NE627 DATE 16JAN2017		Cummins Inc.			
				ITEM NAME GENERAL, ARRANGEMENT CFPI5E-F70			
THIS DOCUMENT AND THE INFORMATION SHOWN THEREON IS CONFIDENTIAL AND PROPRIETARY AND SHALL NOT BE DISCLOSED TO OTHERS IN HARD COPY OR ELECTRONIC FORM, REPRODUCED BY ANY MEANS, OR USED FOR ANY PURPOSE WITHOUT WRITTEN CONSENT OF CUMMINS INC.			FOR INTERPRETATION OF DIMENSIONING AND TOLERANCING, SEE ASME Y14.5-2009	MUST CONFORM TO CES 10903	CAD SHEET 1 OF 5	ITEM NUMBER A042J662	REV 2

LEGEND AND DATUM IDENTIFIER	
SHEET 1	INSTALLATION DRAWING
SHEET 2	GENERAL ARRANGEMENT - HORIZONTAL SPLIT CASE PUMP BASE OPTION
SHEET 3	GENERAL ARRANGEMENT - VERTICAL TURBINE PUMP BASE OPTION
SHEET 4	DRIVE LINE OPTIONS
SHEET 5	ELECTRICAL INFORMATION
DATUM "A"	FACE OF FLYWHEEL HOUSING
DATUM "B"	REAR LEG BOLT LOCATION
DATUM "C"	FLYWHEEL MOUNTING SURFACE
DATUM "D"	UJOINT ADAPTER MOUNTING SURFACE
DATUM "EOS"	END OF PUMP SHAFT

REV	REL NO	REVISION	DWN	CKD	APVD	DATE
-	2016-668	RELEASED TO PRODUCTION	HE392	NE627	NE627	16JAN17
A	2019-211	SEE SHEET 1 FOR REVISION DETAILS	NO134	MS707	MS707	21MAY19
2	2020-021	SEE SHEET 1 FOR REVISION DETAILS	NO134	MS707	MS707	03FEB20

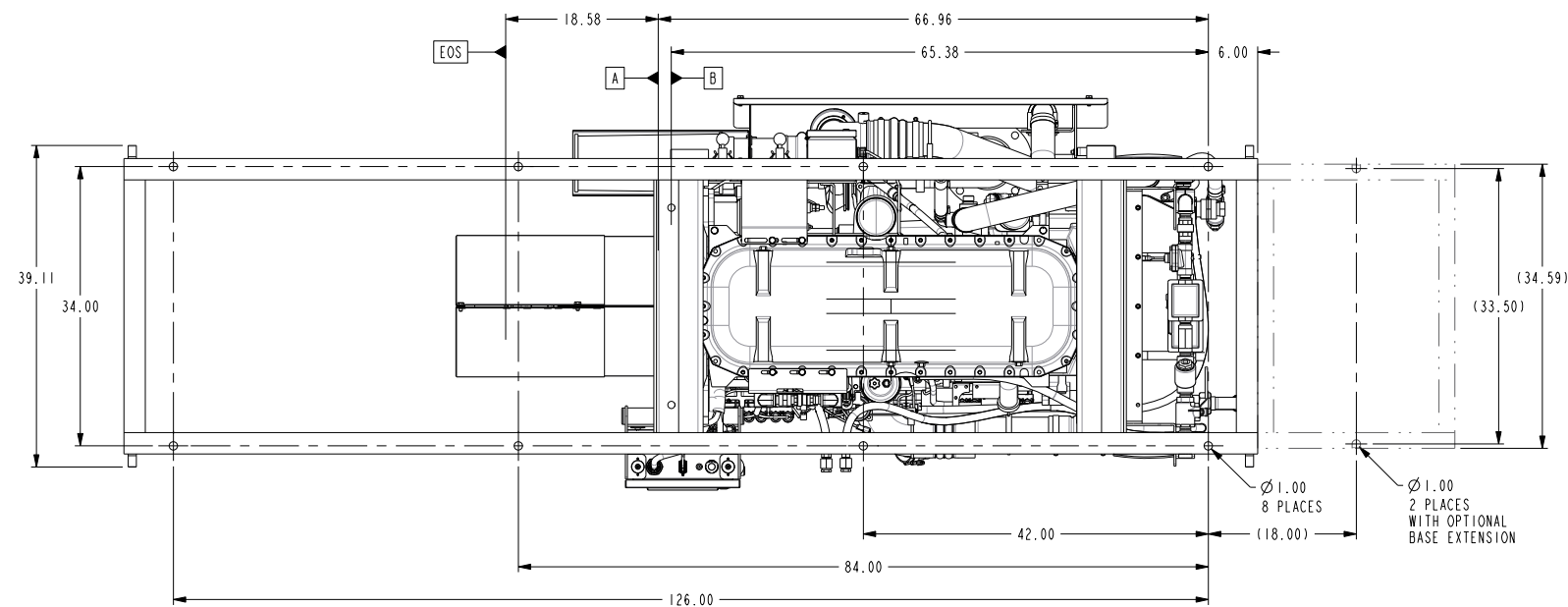
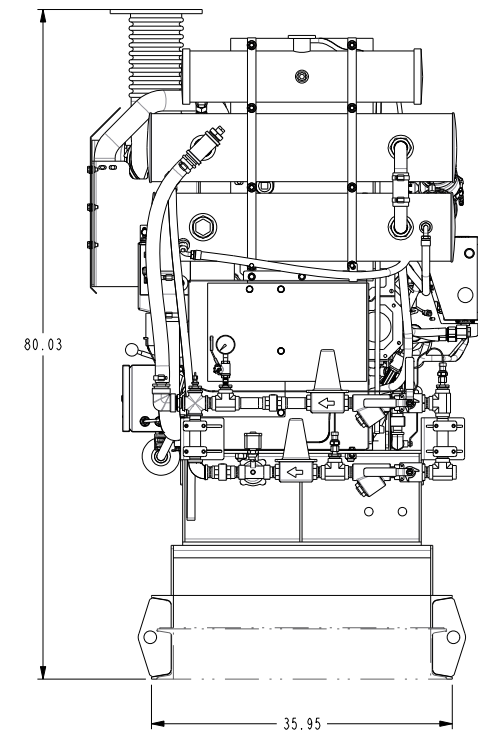
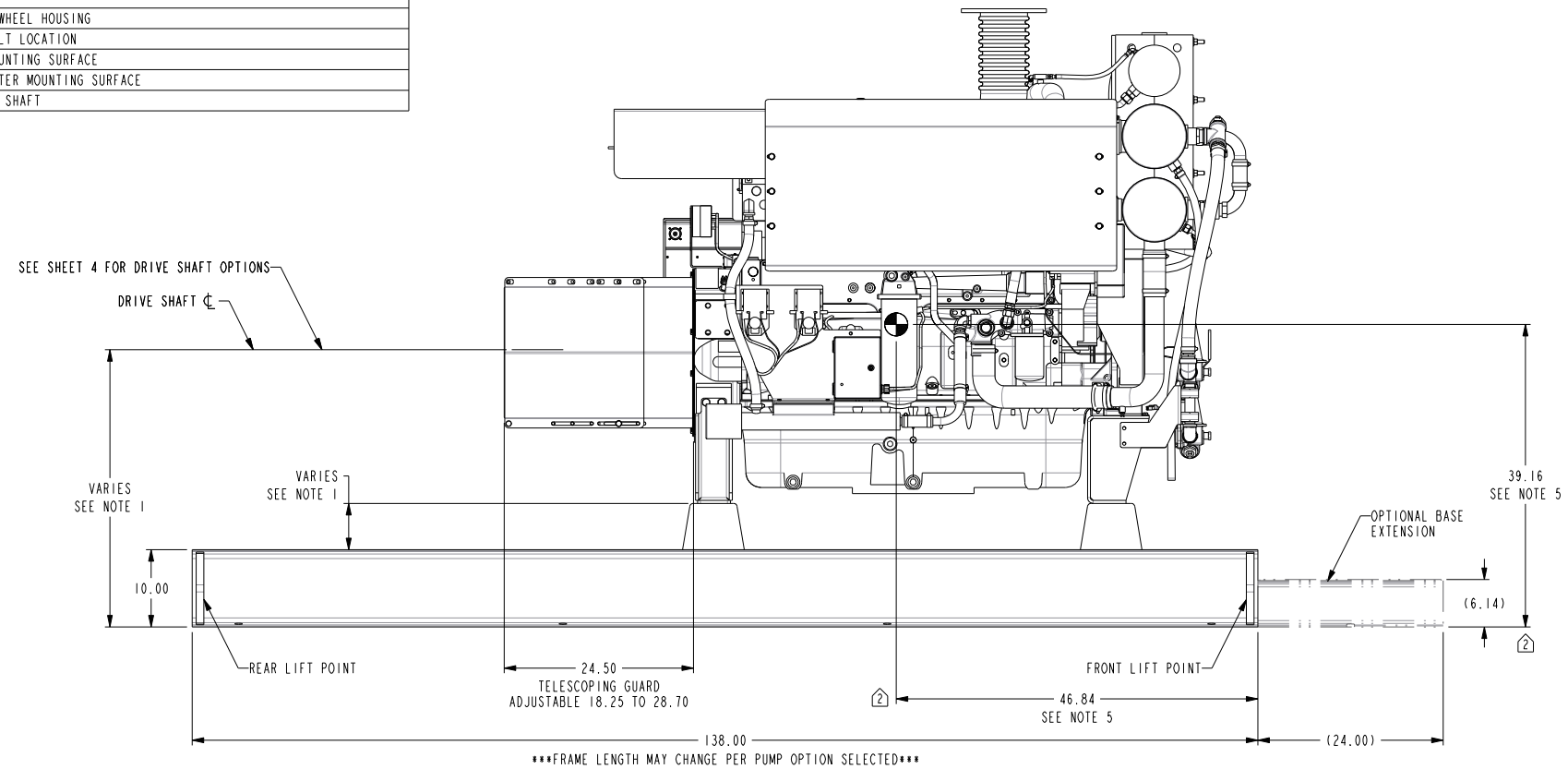

- NOTES:
1. RISER HEIGHT VARIES TO ACCOMMODATE CUSTOMER SUPPLIED PUMPS
 2. REFERENCE OWNERS MANUAL FOR DRIVE SHAFT ALIGNMENT SPECS
 3. DRAWING SUBJECT TO CHANGE WITHOUT NOTICE
 4. REFERENCE SHEET 1 FOR BASE FIRE PUMP INTERFACE
 5. CENTER OF GRAVITY LOCATION IS APPROXIMATE & DOES NOT INCLUDE U-JOINT ADAPTER, DRIVE SHAFT, COMPANION FLANGE, DRIVE SHAFT GUARDS OR BASE EXTENSION

DIMENSIONS ARE IN: INCHES 1:1 ARE IN: DRAWING TOLERANCES APPLY TO PRIMARY DIMENSIONS UNLESS OTHERWISE SPECIFIED	DO NOT SCALE PRINT SCALE 0.094	CM1 DATA CLASSIFICATION Cummins Confidential		Cummins Inc.	
X: ± 1 IN OR 4 mm X,Z: ± 1 IN OR 0.7 mm X,Z: ± 0.00 IN OR 0.25 mm X,Z: ± 0.01 IN OR 0.25 mm ANGULAR TOLERANCE: ±		DWN HE392 CKD NE627 APVD NE627 DATE 16JAN2017		ITEM NAME GENERAL, ARRANGEMENT CF15E-F70	CAD SHEET 2 OF 5
THIS DOCUMENT AND THE INFORMATION SHOWN HEREON IS CONFIDENTIAL AND PROPRIETARY AND SHALL NOT BE DISCLOSED TO OTHERS IN HARD COPY OR ELECTRONIC FORM, REPRODUCED BY ANY MEANS, OR USED FOR ANY PURPOSE WITHOUT WRITTEN CONSENT OF CUMMINS INC.			FOR INTERPRETATION OF DIMENSIONING AND TOLERANCING, SEE ASME Y14.5-2009	MUST CONFORM TO CES 10903	REV 2

LEGEND AND DATUM IDENTIFIER	
SHEET 1	INSTALLATION DRAWING
SHEET 2	GENERAL ARRANGEMENT - HORIZONTAL SPLIT CASE PUMP BASE OPTION
SHEET 3	GENERAL ARRANGEMENT - VERTICAL TURBINE PUMP BASE OPTION
SHEET 4	DRIVE LINE OPTIONS
SHEET 5	ELECTRICAL INFORMATION
DATUM "A"	FACE OF FLYWHEEL HOUSING
DATUM "B"	REAR LEG BOLT LOCATION
DATUM "C"	FLYWHEEL MOUNTING SURFACE
DATUM "D"	UJOINT ADAPTER MOUNTING SURFACE
DATUM "EOS"	END OF PUMP SHAFT

REV	REL NO	REVISION	DWN	CKD	APVD	DATE
-	2016-668	RELEASED TO PRODUCTION	HE392	NE627	NE627	16JAN17
A	2019-211	SEE SHEET 1 FOR REVISION DETAILS	NO134	MS707	MS707	21MAY19
2	2020-021	SEE SHEET 1 FOR REVISION DETAILS	NO134	MS707	MS707	03FEB20

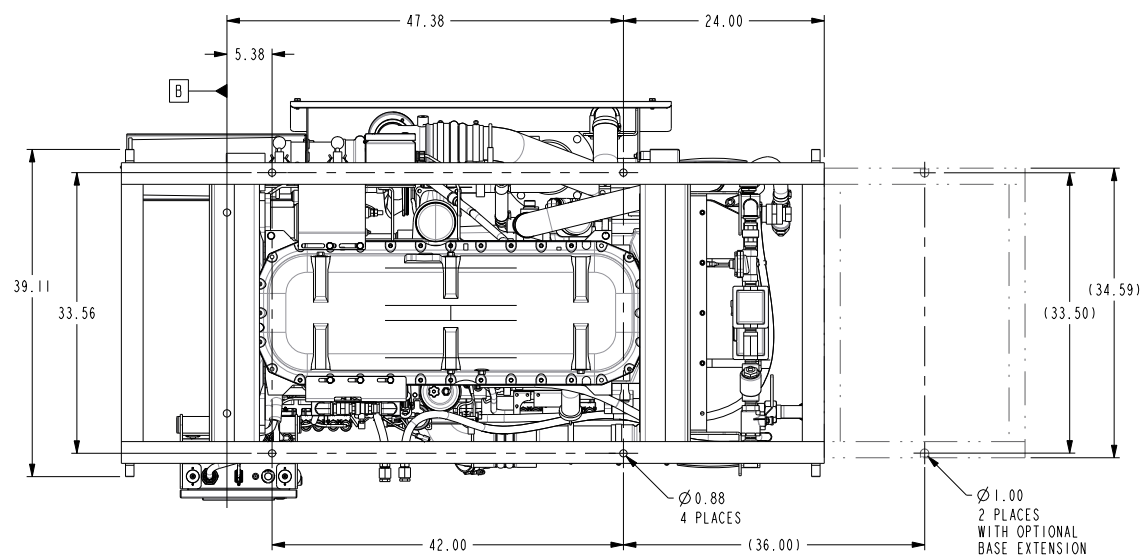
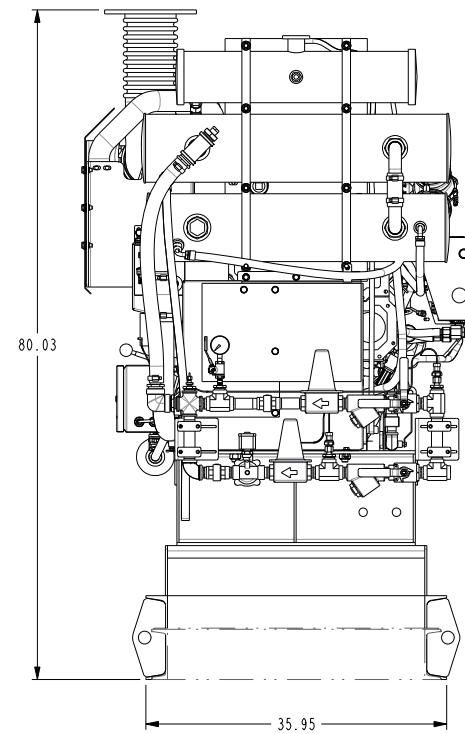
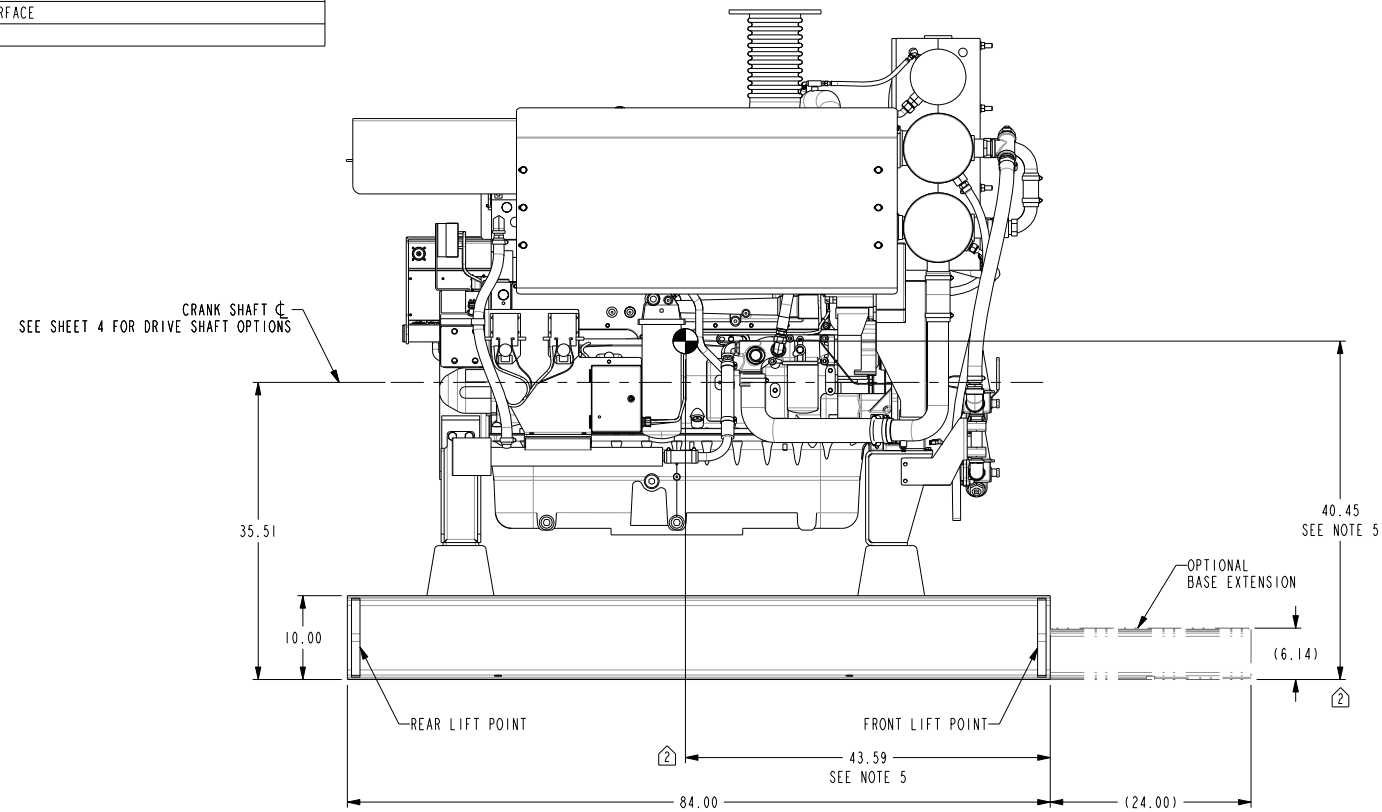

- NOTE:
- TORSIONAL ANALYSIS REQUIRED FOR VERTICAL TURBINE INSTALLATION
 - REFERENCE OWNERS MANUAL FOR DRIVE SHAFT ALIGNMENT SPECS
 - DRAWING SUBJECT TO CHANGE WITHOUT NOTICE
 - REFERENCE SHEET 1 FOR BASE FIRE PUMP INTERFACE
 - CENTER OF GRAVITY LOCATION IS APPROXIMATE & DOES NOT INCLUDE BASE EXTENSION

DIMENSIONS ARE IN: INCHES [] ARE IN: MILLIMETERS DRAWING TOLERANCES APPLY TO PRIMARY DIMENSIONS UNLESS OTHERWISE SPECIFIED X: ± 1 IN OR 4 mm X.II: ± 1 IN OR 0.1 mm X.III: ± 0.00 IN OR 0.25 mm X.IV: ± 0.01 IN OR 0.25 mm ANGULAR TOLERANCES: ±	DO NOT SCALE PRINT SCALE: 0.094	CM1 DATA CLASSIFICATION Cummins Confidential DWN: HE392 CKD: NE627 APVD: NE627 DATE: 16JAN2017	Cummins Inc. ITEM NAME GENERAL, ARRANGEMENT CFP15E-F70 FOR INTERPRETATION OF DIMENSIONING AND TOLERANCING, SEE ASME Y14.5-2009	MUST CONFORM TO CES 10903	CAD SHEET 3 OF 5 ITEM NUMBER A042J662 REV 2
--	------------------------------------	---	--	---------------------------	---

LEGEND AND DATUM IDENTIFIER	
SHEET 1	INSTALLATION DRAWING
SHEET 2	GENERAL ARRANGEMENT - HORIZONTAL SPLIT CASE PUMP BASE OPTION
SHEET 3	GENERAL ARRANGEMENT - VERTICAL TURBINE PUMP BASE OPTION
SHEET 4	DRIVE LINE OPTIONS
SHEET 5	ELECTRICAL INFORMATION
DATUM "A"	FACE OF FLYWHEEL HOUSING
DATUM "B"	REAR LEG BOLT LOCATION
DATUM "C"	FLYWHEEL MOUNTING SURFACE
DATUM "D"	UJOINT ADAPTER MOUNTING SURFACE
DATUM "EOS"	END OF PUMP SHAFT

CFP DRIVE SHAFT MATRIX	
CFP F RATINGS WITH MULTIPLE SHAFTS	
ENGINE MODEL	RPM
CFP15E-F70	NON LISTED 3172 SHAFT

REV	REL NO	REVISION	DWN	CKD	APVD	DATE
-	2016-668	RELEASED TO PRODUCTION	HE392	NE627	NE627	16JAN17
A	2019-211	SEE SHEET 1 FOR REVISION DETAILS	NO134	MS707	MS707	21MAY19
2	2020-021	SEE SHEET 1 FOR REVISION DETAILS	NO134	MS707	MS707	03FEB20

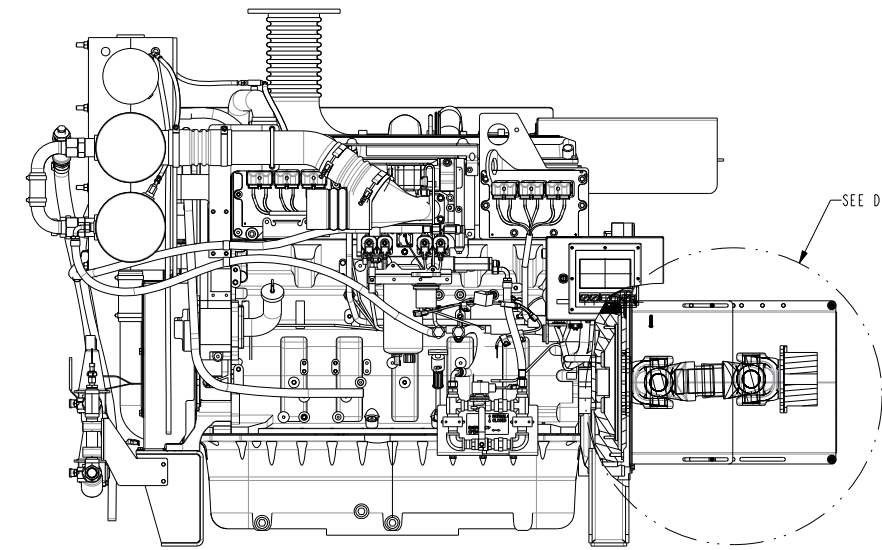
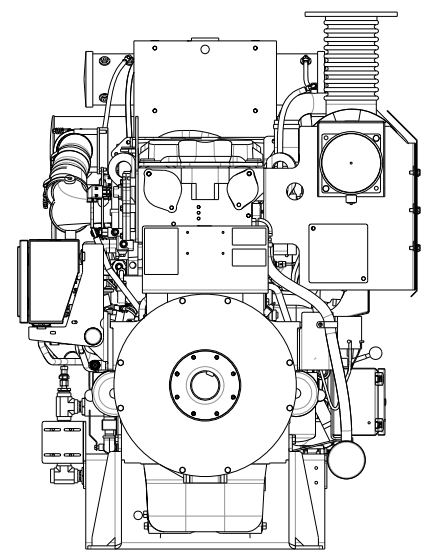
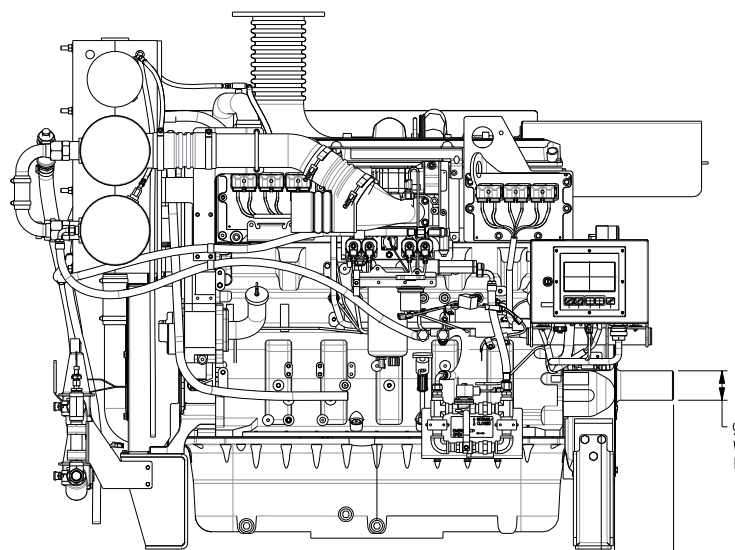

SECTION A-A

Ø 3.50 STUB SHAFT
WITH 0.875 x 0.438
KEYWAY

7.05
8.63

3/8"-16 UNC TAP
12 HOLES EQUALLY SPACED
ON A Ø13.13 BOLT CIRCLE

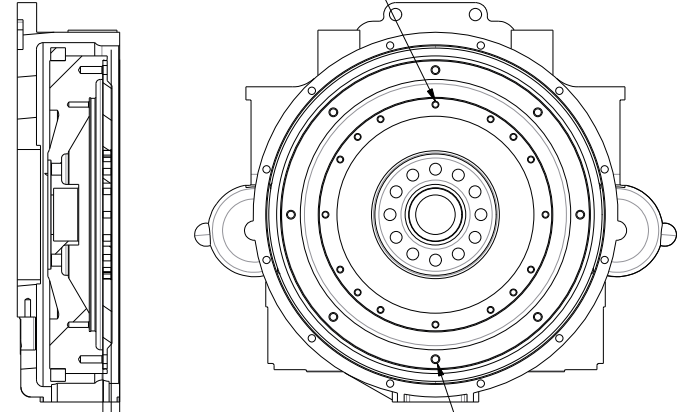

1/2"-13 UNC TAP
8 HOLES EQUALLY SPACED
ON A Ø17.25 BOLT CIRCLE

0.51
1.00

SECTION A-A

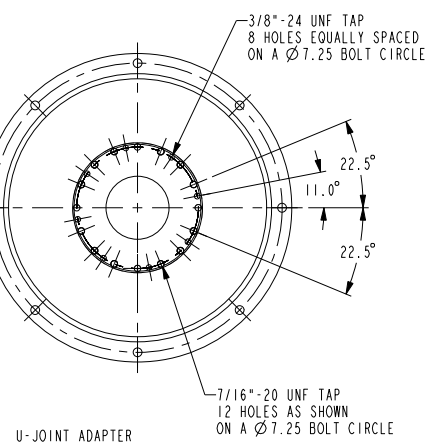
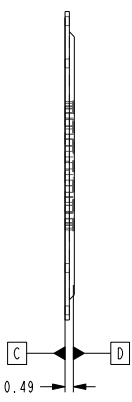

U-JOINT ADAPTER

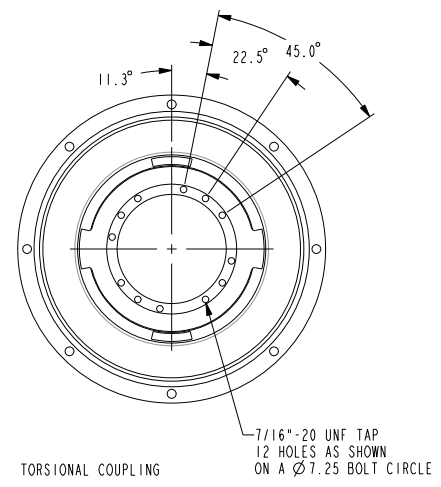
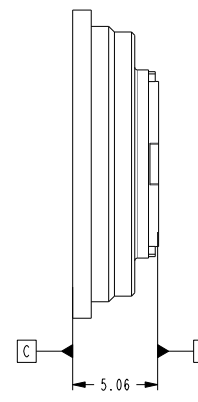

TORSIONAL COUPLING

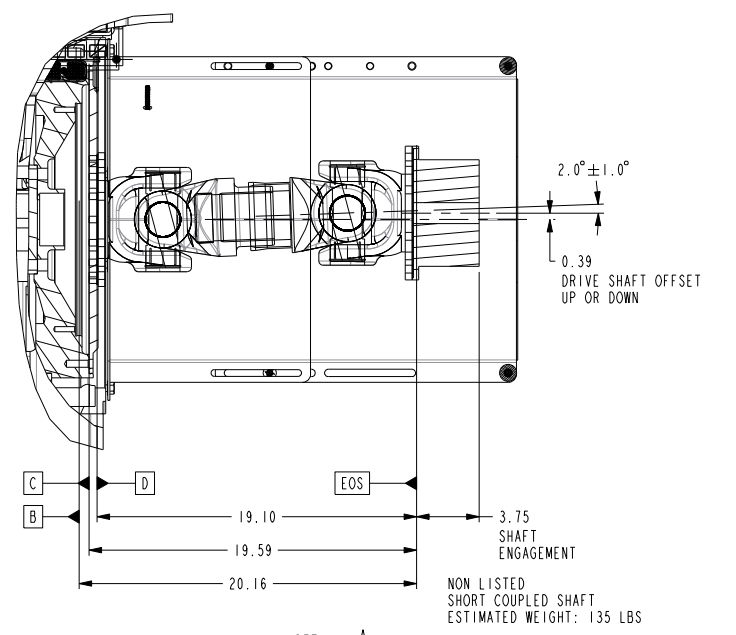

DETAIL A
SCALE 0.188

2.0° ± 1.0°
0.39
DRIVE SHAFT OFFSET
UP OR DOWN

3.75
SHAFT
ENGAGEMENT

NON LISTED
SHORT COUPLED SHAFT
ESTIMATED WEIGHT: 135 LBS

19.10
19.59
20.16

- NOTE:
1. TORSIONAL ANALYSIS REQUIRED FOR VERTICAL TURBINE INSTALLATION
 2. REFERENCE OWNERS MANUAL FOR DRIVE SHAFT ALIGNMENT SPECS
 3. DRAWING SUBJECT TO CHANGE WITHOUT NOTICE.
 4. REFERENCE SHEET 1 FOR BASE FIRE PUMP INTERFACE

DIMENSIONS ARE IN: INCHES 1, 2 ARE IN:	DO NOT SCALE PRINT SCALE 0.094	CMV DATA CLASSIFICATION Cummins Confidential		Cummins Inc.	
DRAWING TOLERANCES APPLY TO PRIMARY DIMENSIONS UNLESS OTHERWISE SPECIFIED X: ± 1 IN OR 4 mm X.2: ± 1 IN OR 0.1 mm X.12: ± 0.00 IN OR 0.25 mm X.125: ± 0.01 IN OR 0.25 mm ANGULAR TOLERANCE: ±		DWN HE392 CKD NE627 APVD NE627 DATE 16JAN2017		ITEM NAME GENERAL, ARRANGEMENT CFP15E-F70	CAD SHEET 4 OF 5
THIS DOCUMENT AND THE INFORMATION SHOWN THEREON IS CONFIDENTIAL AND PROPRIETARY AND SHALL NOT BE DISCLOSED TO OTHERS IN HARD COPY OR ELECTRONIC FORM, REPRODUCED BY ANY MEANS, OR USED FOR ANY PURPOSE WITHOUT WRITTEN CONSENT OF CUMMINS INC.			FOR INTERPRETATION OF DIMENSIONING AND TOLERANCING, SEE ASME Y14.5-2009		MUST CONFORM TO CES 10903

LEGEND AND DATUM IDENTIFIER	
SHEET 1	INSTALLATION DRAWING
SHEET 2	GENERAL ARRANGEMENT - HORIZONTAL SPLIT CASE PUMP BASE OPTION
SHEET 3	GENERAL ARRANGEMENT - VERTICAL TURBINE PUMP BASE OPTION
SHEET 4	DRIVE LINE OPTIONS
SHEET 5	ELECTRICAL INFORMATION
DATUM "A"	FACE OF FLYWHEEL HOUSING
DATUM "B"	REAR LEG BOLT LOCATION
DATUM "C"	FLYWHEEL MOUNTING SURFACE
DATUM "D"	UJOINT ADAPTER MOUNTING SURFACE
DATUM "EOS"	END OF PUMP SHAFT

REV	REL NO	REVISION	DWN	CKD	APVD	DATE
-	2016-668	RELEASED TO PRODUCTION	HE392	NE627	NE627	16JAN17
A	2019-211	SEE SHEET 1 FOR REVISION DETAILS	NO134	MS707	MS707	21MAY19
2	2020-021	SEE SHEET 1 FOR REVISION DETAILS	NO134	MS707	MS707	03FEB20

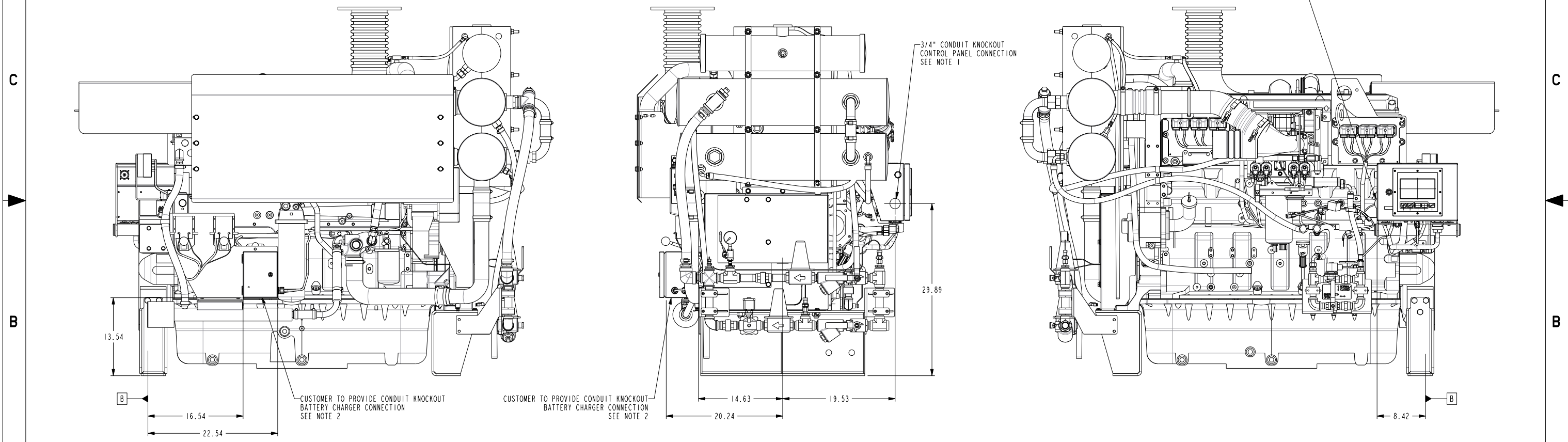



- NOTES:
- CONTROL PANEL TERMINAL BLOCKS
1, 2, 3, 4, 5, 9, 10, 301, 302, 303, 304, 310, 311, 312
 - BATTERY CHARGER CONNECTION BOX TERMINAL BLOCKS
6, 8, 11

DIMENSIONS ARE IN: INCHES [] ARE IN:	DO NOT SCALE PRINT SCALE 0.125	CMI DATA CLASSIFICATION Cummins Confidential		Cummins Inc.											
DRAWING TOLERANCES APPLY TO PRIMARY DIMENSIONS UNLESS OTHERWISE SPECIFIED X: ± 1 IN OR 4 mm X.I: ± 1 IN OR 0.1 mm X.IX: ± 0.00 IN OR 0.25 mm X.IX: ± 0.01 IN OR 0.25 mm ANGULAR TOLERANCE: ±		FOR INTERPRETATION OF DIMENSIONING AND TOLERANCING, SEE ASME Y14.5-2009		<table border="1"> <tr> <td>DWN</td> <td>HE392</td> </tr> <tr> <td>CKD</td> <td>NE627</td> </tr> <tr> <td>APVD</td> <td>NE627</td> </tr> <tr> <td>DATE</td> <td>16JAN2017</td> </tr> </table>	DWN	HE392	CKD	NE627	APVD	NE627	DATE	16JAN2017	ITEM NAME GENERAL, ARRANGEMENT CFP15E-F70	CAD SHEET 5 OF 5	ITEM NUMBER A042J662
DWN	HE392														
CKD	NE627														
APVD	NE627														
DATE	16JAN2017														
<small>THIS DOCUMENT AND THE INFORMATION SHOWN HEREON IS CONFIDENTIAL AND PROPRIETARY AND SHALL NOT BE DISCLOSED TO OTHERS IN HARD COPY OR ELECTRONIC FORM, REPRODUCED BY ANY MEANS, OR USED FOR ANY PURPOSE WITHOUT WRITTEN CONSENT OF CUMMINS INC.</small>			MUST CONFORM TO CES 10903												

BILL OF MATERIAL			
ITEM	QTY	DESCRIPTION	PART NUMBER
1	2	CONTACTOR, MANUAL OVERRIDE, 24V; PN:535-0098, FIREPUMP	8824-24
2	1	EXHAUST, L 90 HALF MARMON; 6" 125# ANSI FLANGE	9514-06
3	1	ASSEMBLY, SUPPORT; CFP15E FIRE PUMP	10835
4	1	ASSEMBLY, AIR CLEANER; CFP15E	10856-01
5	1	ASSEMBLY, HEAT EXCHANGER; LOW HP, CFP15E	11492-01
6	1	ASSEMBLY, GUARDING; CFP15E	16707
7	1	ASSEMBLY, FUEL VALVE AND BYPASS;	18501
8	1	ASSEMBLY, CONTROL PANEL MOUNTING; CFP POWER UNITS	21249
9	1	MISCELLANEOUS PIPING; RAW WATER, CFP15E	A042A257
10	1	ENCLOSURE, INTERFACE; BATTERY CHARGER FIRE PUMP	A042C868
11	1	ASSEMBLY, SENSORS & HARNESSING; CFP15E	A042H297
12	1	COOLING LOOP, 1", 24V; RAW WATER	A042H732
13	1	CONTROL ASSEMBLY; FPDP ELECTRONIC CARBON STEEL	A042H780
14	1	ASSEMBLY, ACCESSORY MOUNTING; CFP15E	A042J030
15	1	ASSEMBLY, COOLANT HEATER; CFP15E	A042J191
16	1	ASSEMBLY, SECONDARY ECM; CFP15E	A042J761
17	1	ASSEMBLY, FUEL LINE; CFP15E	A042J765
18	1	ASSEMBLY, 24VDC ENGINE; CFP15E-F10/20/30/40	A042K083
19	1	PAINT, SPRAY BOMB; CUMMINS RED, ES044 RAL 3001	A15730-A12
20	1	PLUG, 1/2 NPT;	LTL-SCSP12

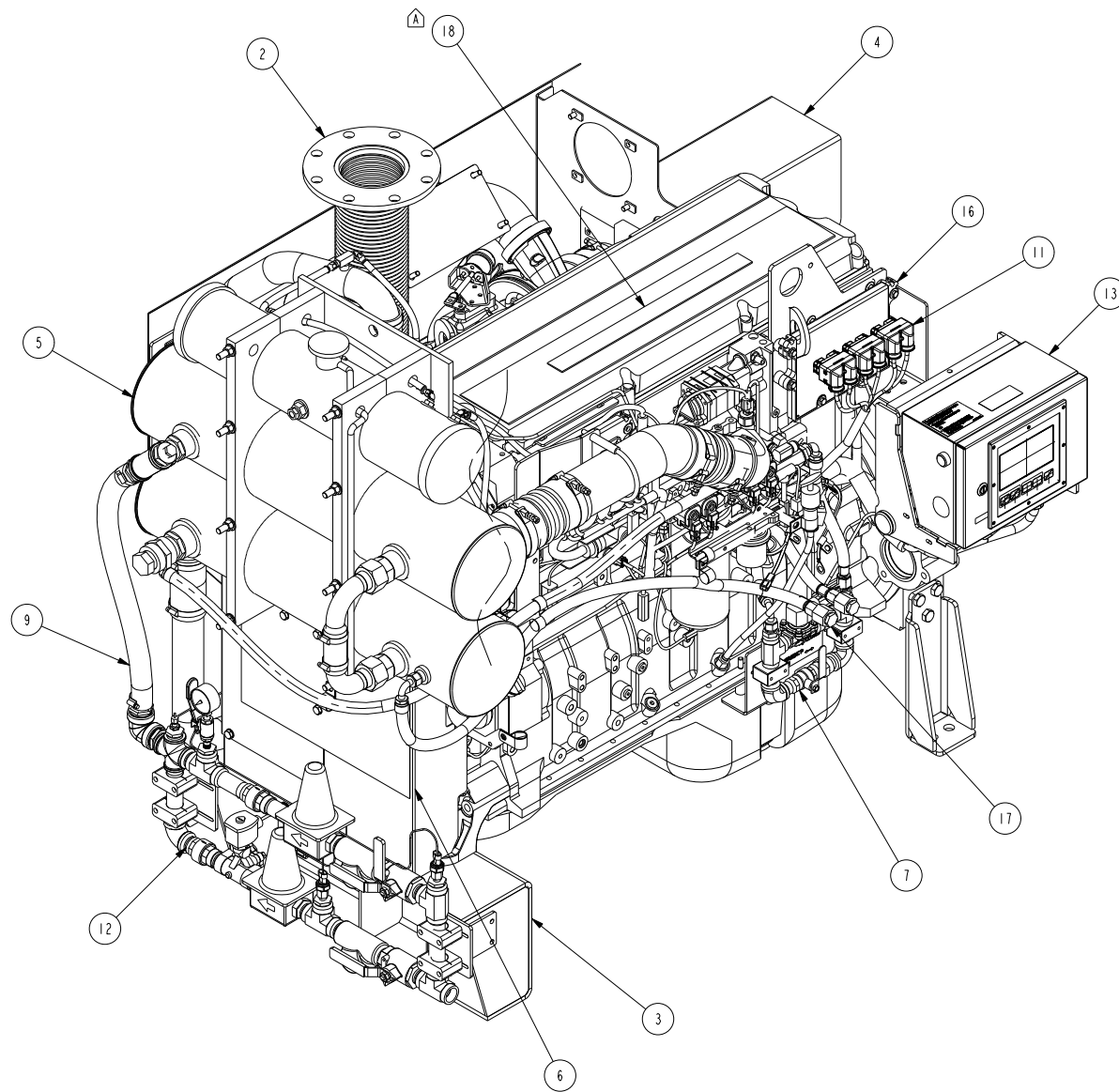
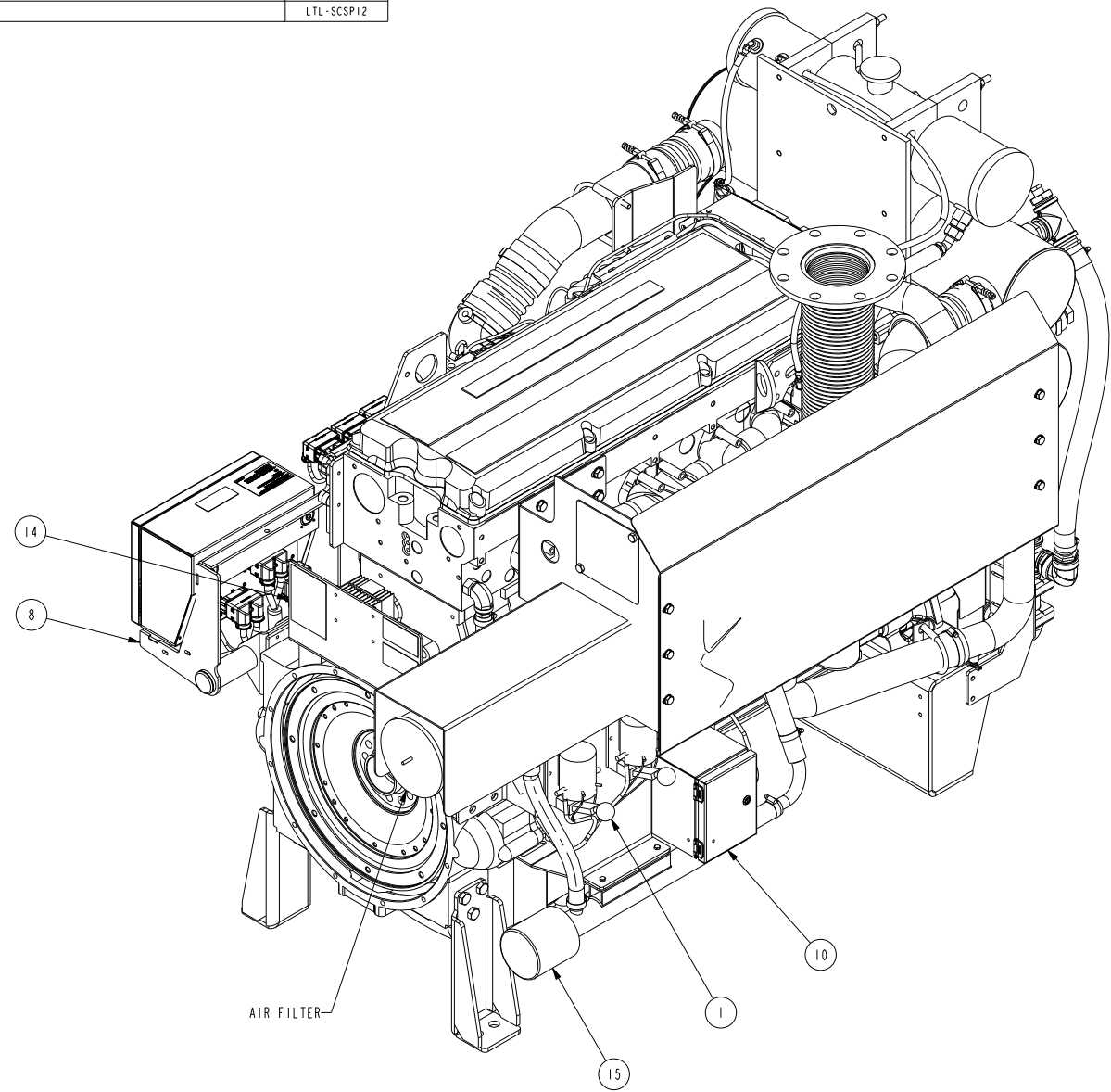
REV	REL NO	REVISION	DWN	CKD	APVD	DATE
A	2017-137	DELETE 16779. ADD A042K083	HE392	HE392	HE392	09MAR17
2	2020-021	REMOVED CFP15E-F40 FROM ITEM NAME; UPDATED PER A042J765	NO134	MS707	MS707	19FEB20



DIMENSIONS ARE IN: INCHES 1:1 ARE IN:	DO NOT SCALE PRINT SCALE 0.150	CMI DATA CLASSIFICATION Cummins Confidential		Cummins Inc.							
DRAWING TOLERANCES APPLY TO PRIMARY DIMENSIONS UNLESS OTHERWISE SPECIFIED X: ± .10 IN OR 3 mm Y: ± .10 IN OR 3 mm Z: ± .03 IN OR 0.75 mm H: ± .010 IN OR 0.25 mm M: ± .010 IN OR 0.25 mm R: ± .010 IN OR 0.25 mm ANGULAR TOLERANCE: ±	SCALE 0.150	DWN: HE392 CKD: HE392 APVD: HE392 DATE: 25OCT2016		ITEM NAME ASSEMBLY, FIRE PUMP CFP15E-F10/20/30							
THIS DOCUMENT (AND THE INFORMATION SHOWN THEREIN) IS CONFIDENTIAL AND PROPRIETARY AND SHALL NOT BE DISCLOSED TO OTHERS IN HARD COPY OR ELECTRONIC FORM, REPRODUCED BY ANY MEANS, OR USED FOR ANY PURPOSE WITHOUT WRITTEN CONSENT OF CUMMINS INC.			FOR INTERPRETATION OF DIMENSIONING AND TOLERANCING, SEE ASME Y14.5-2009	MUST CONFORM TO CES 10903	<table border="1"> <tr> <td>CAD SHEET</td> <td>ITEM NUMBER</td> <td>REV</td> </tr> <tr> <td>1 OF 3</td> <td>A042H685</td> <td>2</td> </tr> </table>	CAD SHEET	ITEM NUMBER	REV	1 OF 3	A042H685	2
CAD SHEET	ITEM NUMBER	REV									
1 OF 3	A042H685	2									

REV	REL NO	REVISION	DWN	CKD	APVD	DATE
A	2017-137	SEE SHEET 1 FOR REVISION DETAILS	HE392	HE392	HE392	09MAR17
2	2020-021	SEE SHEET 1 FOR REVISION DETAILS	NO134	MS707	MS707	19FEB20

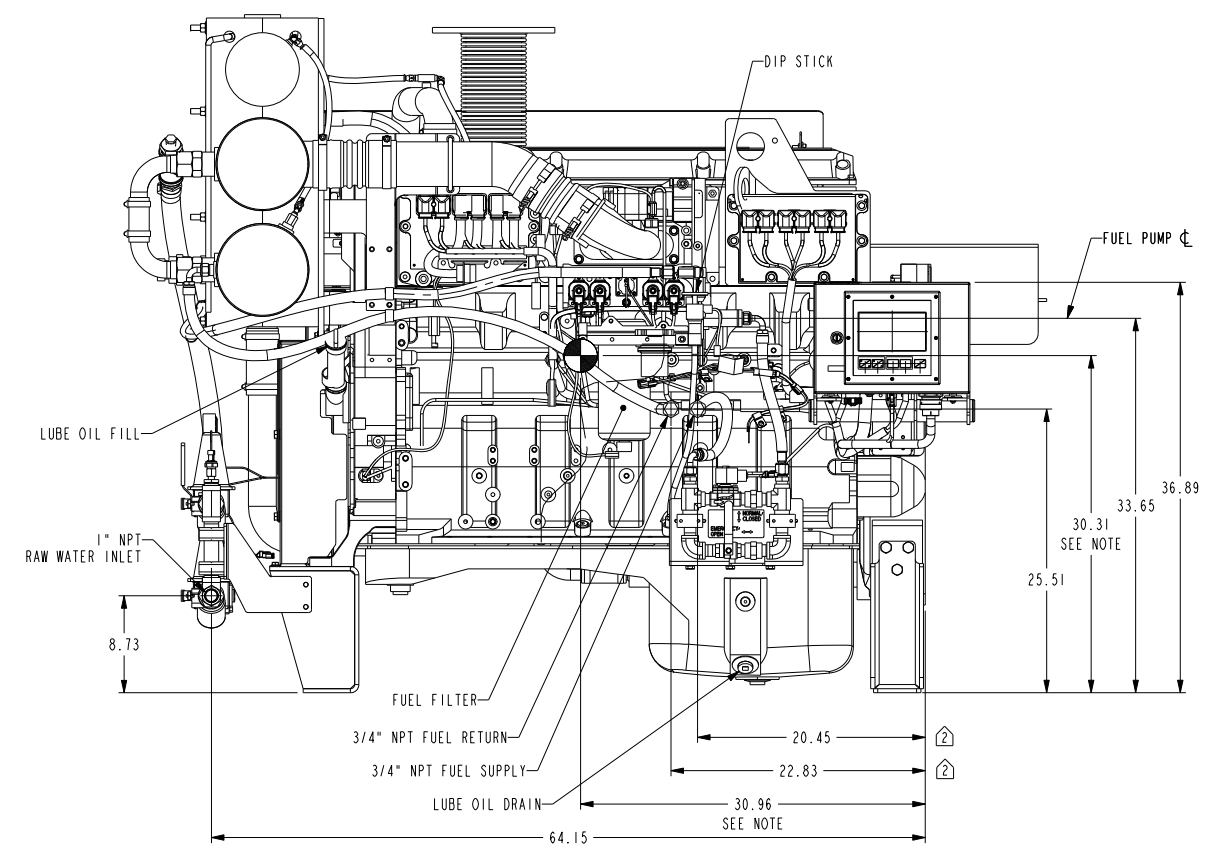
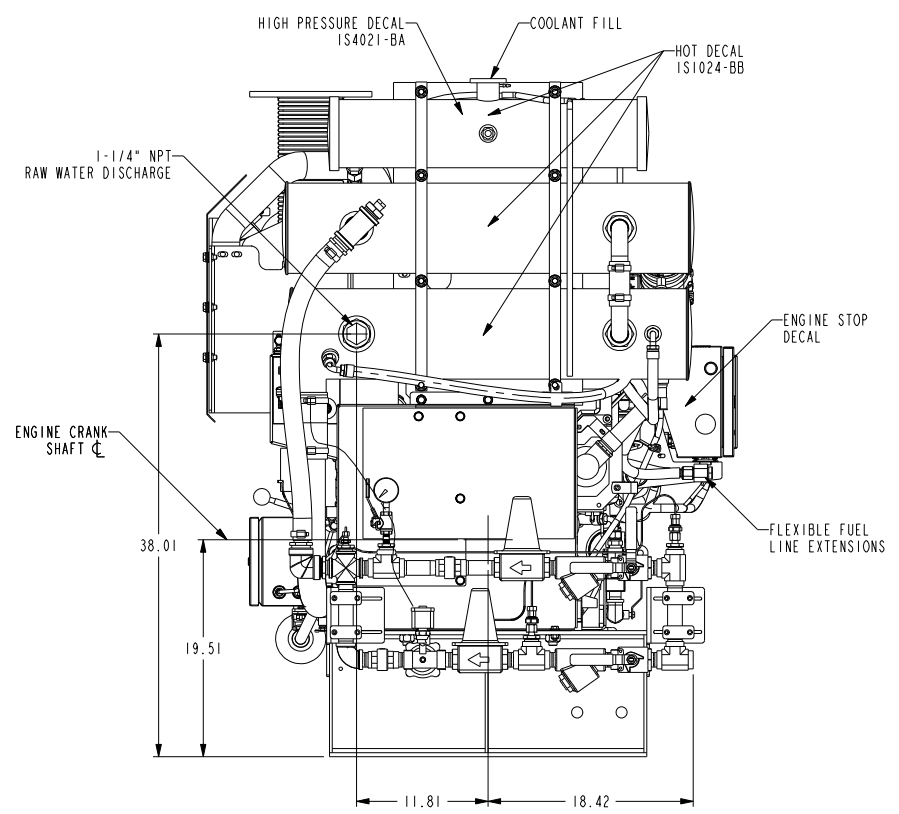
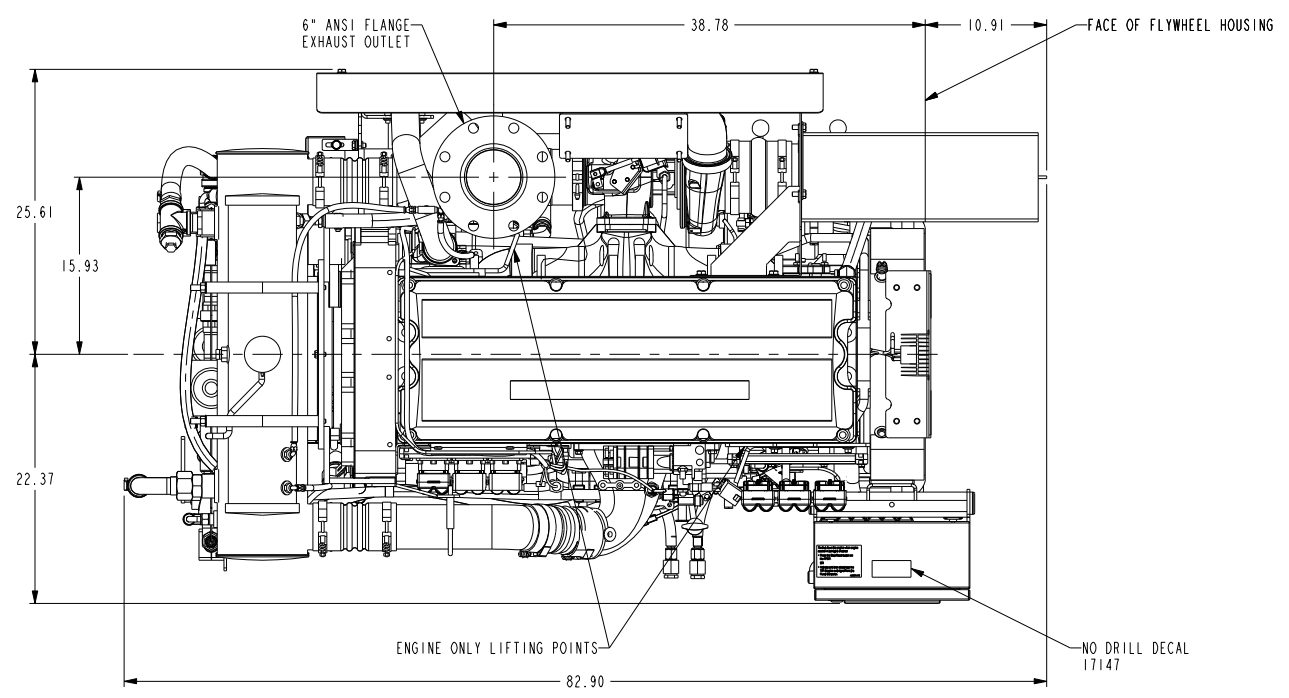

NOTE:
1. CENTER OF GRAVITY LOCATION IS APPROXIMATE

DIMENSIONS ARE IN: INCHES 1:1 ARE IN: DRAWING TOLERANCES APPLY TO PRIMARY DIMENSIONS UNLESS OTHERWISE SPECIFIED F: ± .10 IN OR 4 mm X.X: ± .1 IN OR 3 mm X.XX: ± .030 IN OR 0.75 mm X.XXX: ± .010 IN OR 0.25 mm ANGULAR TOLERANCE: ±	DO NOT SCALE PRINT SCALE 0.125 	CMI DATA CLASSIFICATION Cummins Confidential DWN: HE392 CKD: HE392 APVD: HE392 DATE: 25OCT2016		Cummins Inc.	
				ITEM NAME ASSEMBLY, FIRE PUMP CFPI5E-F10/20/30	
THIS DOCUMENT (AND THE INFORMATION SHOWN THEREON) IS CONFIDENTIAL AND PROPRIETARY AND SHALL NOT BE DISCLOSED TO OTHERS IN HARD COPY OR ELECTRONIC FORM, REPRODUCED BY ANY MEANS, OR USED FOR ANY PURPOSE WITHOUT WRITTEN CONSENT OF CUMMINS INC.			FOR INTERPRETATION OF DIMENSIONING AND TOLERANCING, SEE ASME Y14.5-2009		MUST CONFORM TO CES 10903
CAD SHEET 2 OF 3		ITEM NUMBER A042H685		REV 2	

REV	REL NO	REVISION	DWN	CKD	APVD	DATE
A	2017-137	SEE SHEET 1 FOR REVISION DETAILS	HE392	HE392	HE392	09MAR17
2	2020-021	SEE SHEET 1 FOR REVISION DETAILS	NO134	MS707	MS707	19FEB20

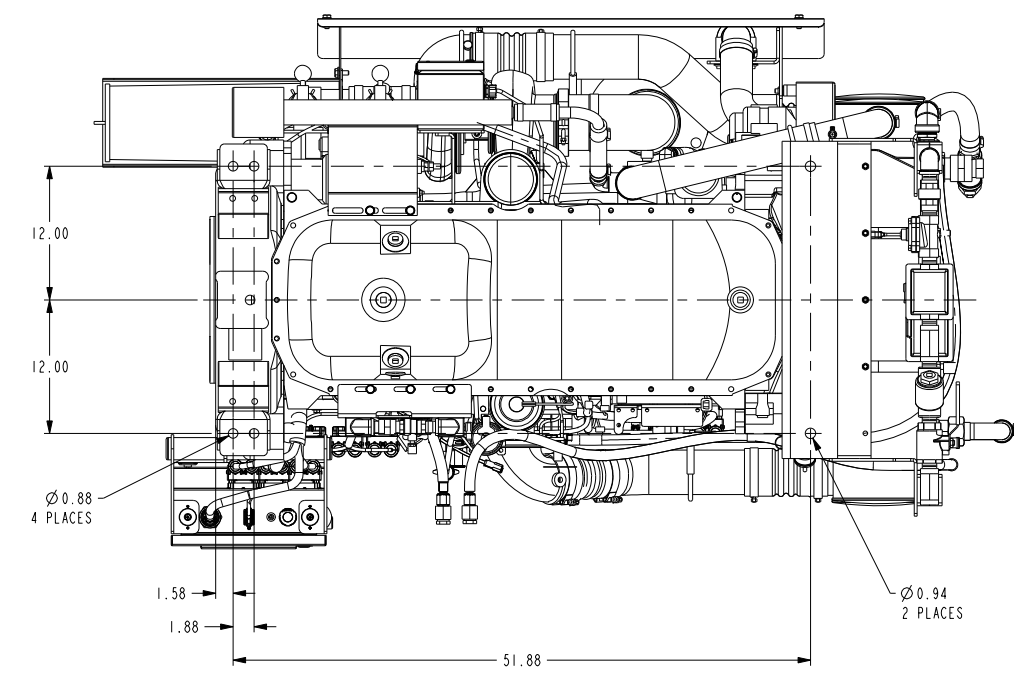
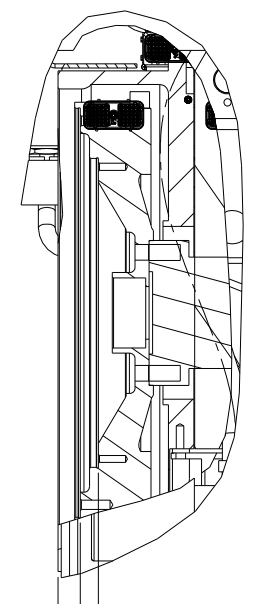
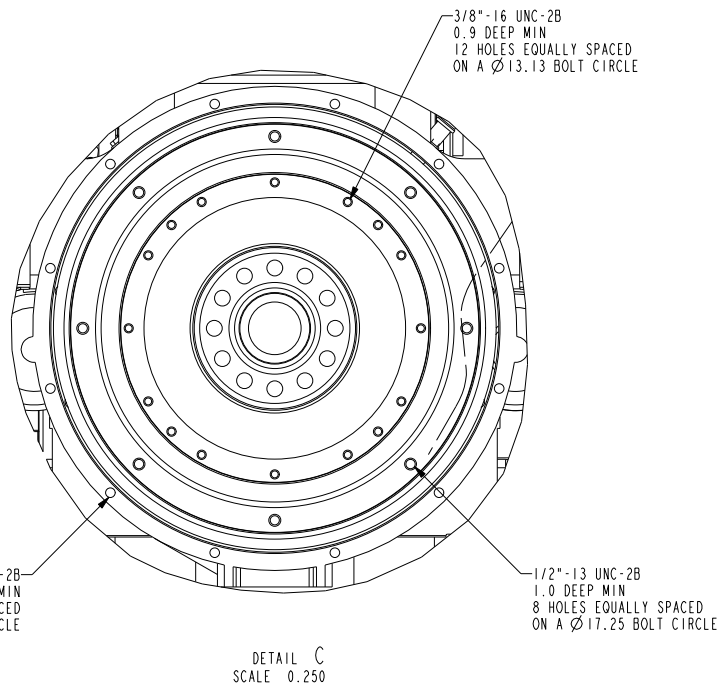
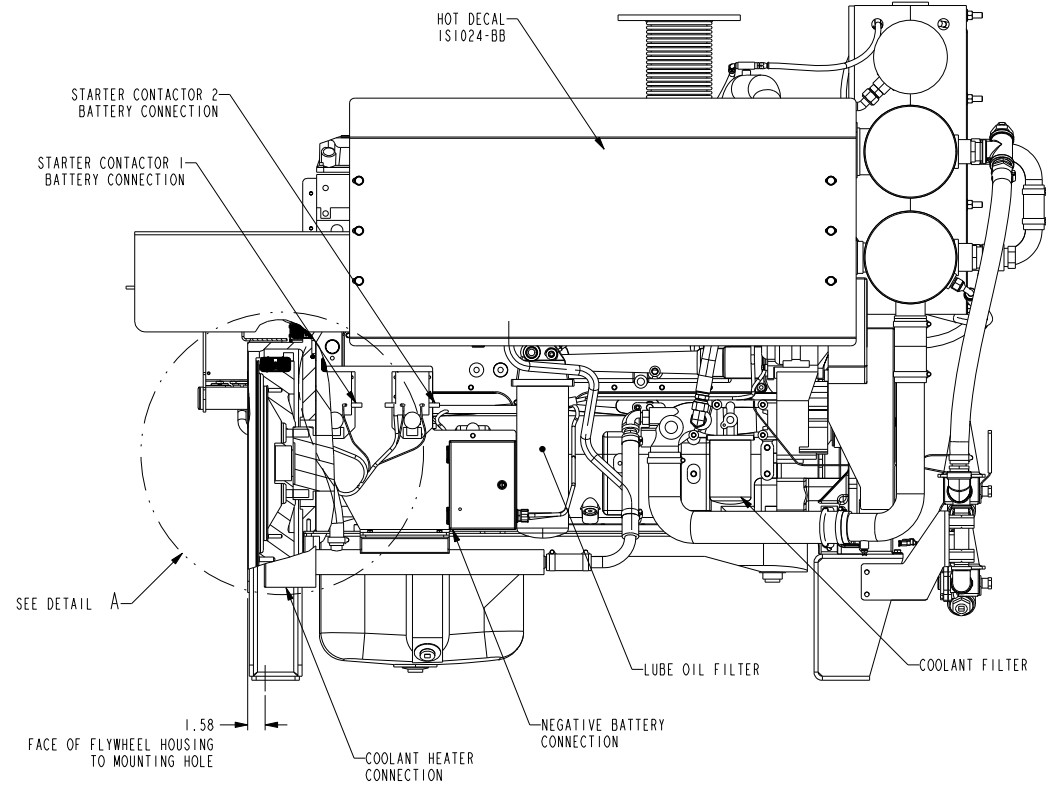
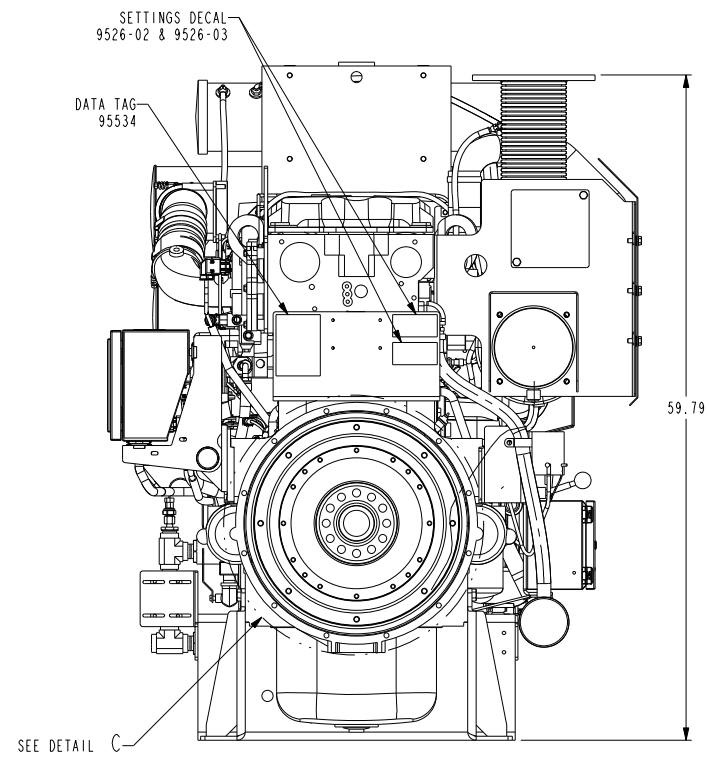

DIMENSIONS ARE IN: INCHES 1:1 ARE IN: DRAWING TOLERANCES APPLY TO PRIMARY DIMENSIONS UNLESS OTHERWISE SPECIFIED F: ± .10 IN OR 0.7 mm M: ± .01 IN OR 0.25 mm H: ± .010 IN OR 0.25 mm ANGULAR TOLERANCE: ±	DO NOT SCALE PRINT SCALE 0.125	CMI DATA CLASSIFICATION Cummins Confidential DWN: HE392 CKD: HE392 APVD: HE392 DATE: 25OCT2016		Cummins Inc. ITEM NAME ASSEMBLY, FIRE PUMP CFP15E-F10/20/30	
				THIS DOCUMENT (AND THE INFORMATION SHOWN THEREIN) IS CONFIDENTIAL AND PROPRIETARY AND SHALL NOT BE DISCLOSED TO OTHERS IN HARD COPY OR ELECTRONIC FORM, REPRODUCED BY ANY MEANS, OR USED FOR ANY PURPOSE WITHOUT WRITTEN CONSENT OF CUMMINS INC.	FOR INTERPRETATION OF DIMENSIONING AND TOLERANCING, SEE ASME Y14.5-2009

BILL OF MATERIAL			
ITEM	QTY	DESCRIPTION	PART NUMBER
1	2	CONTACTOR, MANUAL OVERRIDE, 24V; PN:535-0098, FIREPUMP	8824-24
2	1	ASSEMBLY, SUPPORT; CFP15E FIRE PUMP	10835
3	1	ASSEMBLY, AIR CLEANER; CFP15E	10856-02
4	1	ASSEMBLY, HEAT EXCHANGER; HIGH HP, CFP15E	11492-02
5	1	ASSEMBLY, GUARDING; CFP15E	16707
6	1	ASSEMBLY, FUEL VALVE AND BYPASS;	18501
7	1	ASSEMBLY, CONTROL PANEL MOUNTING; CFP POWER UNITS	21249
8	1	MISCELLANEOUS PIPING; RAW WATER, CFP15E	A042A257
9	1	ENCLOSURE, INTERFACE; BATTERY CHARGER FIRE PUMP	A042C868
10	1	ASSEMBLY, SENSORS & HARNESSING; CFP15E	A042H297
11	1	COOLING LOOP, 1", 24V; RAW WATER	A042H732
12	1	CONTROL ASSEMBLY; FPDP ELECTRONIC CARBON STEEL	A042H780
13	1	ASSEMBLY, ACCESSORY MOUNTING; CFP15E	A042J030
14	1	ASSEMBLY, COOLANT HEATER; CFP15E	A042J191
15	1	ASSEMBLY, SECONDARY ECM; CFP15E	A042J761
16	1	ASSEMBLY, FUEL LINE; CFP15E	A042J765
17	1	ASSEMBLY, 24VDC ENGINE; CFP15E-F45/50/60/70	A042K085
18	1	TUBE, EXHAUST TRANSFER; 6", FLEX, FLARE TO 6" ANSI FLANGE	A058M343
19	1	PAINT, SPRAY BOMB; CUMMINS RED, ES044 RAL 3001	A15730-A12

REV	REL NO	REVISION	DWN	CKD	APVD	DATE
-	2016-668	RELEASED TO PRODUCTION	HE392	-	-	25OCT16
B	2019-211	REPLACED 13572 W/ A058M343	N0134	MS707	MS707	10MAY19
3	2019-580	ADDED DIMENSIONS & NOTE; UPDATED PER A042J765	N0134	MS707	MS707	03DEC19

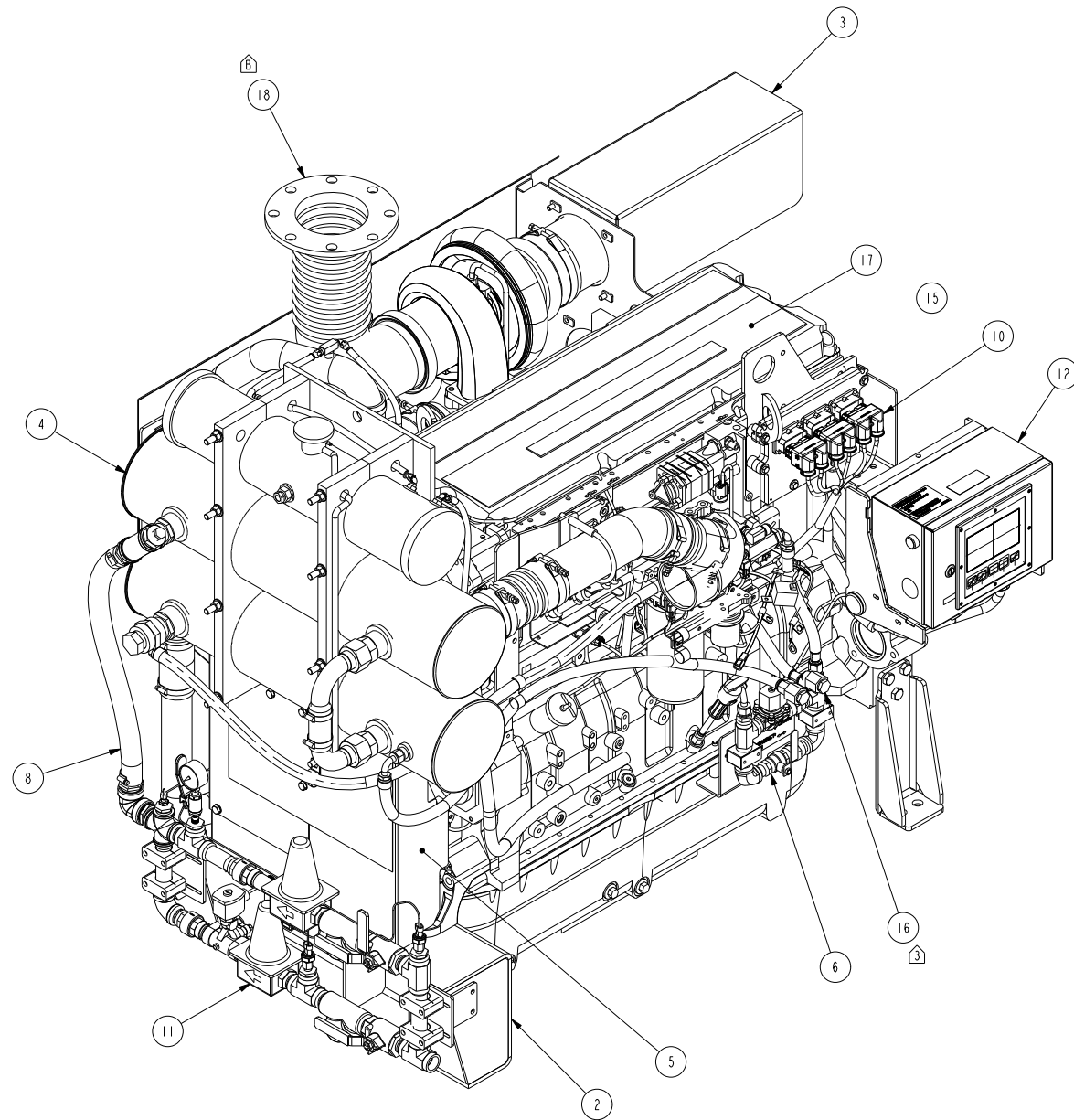
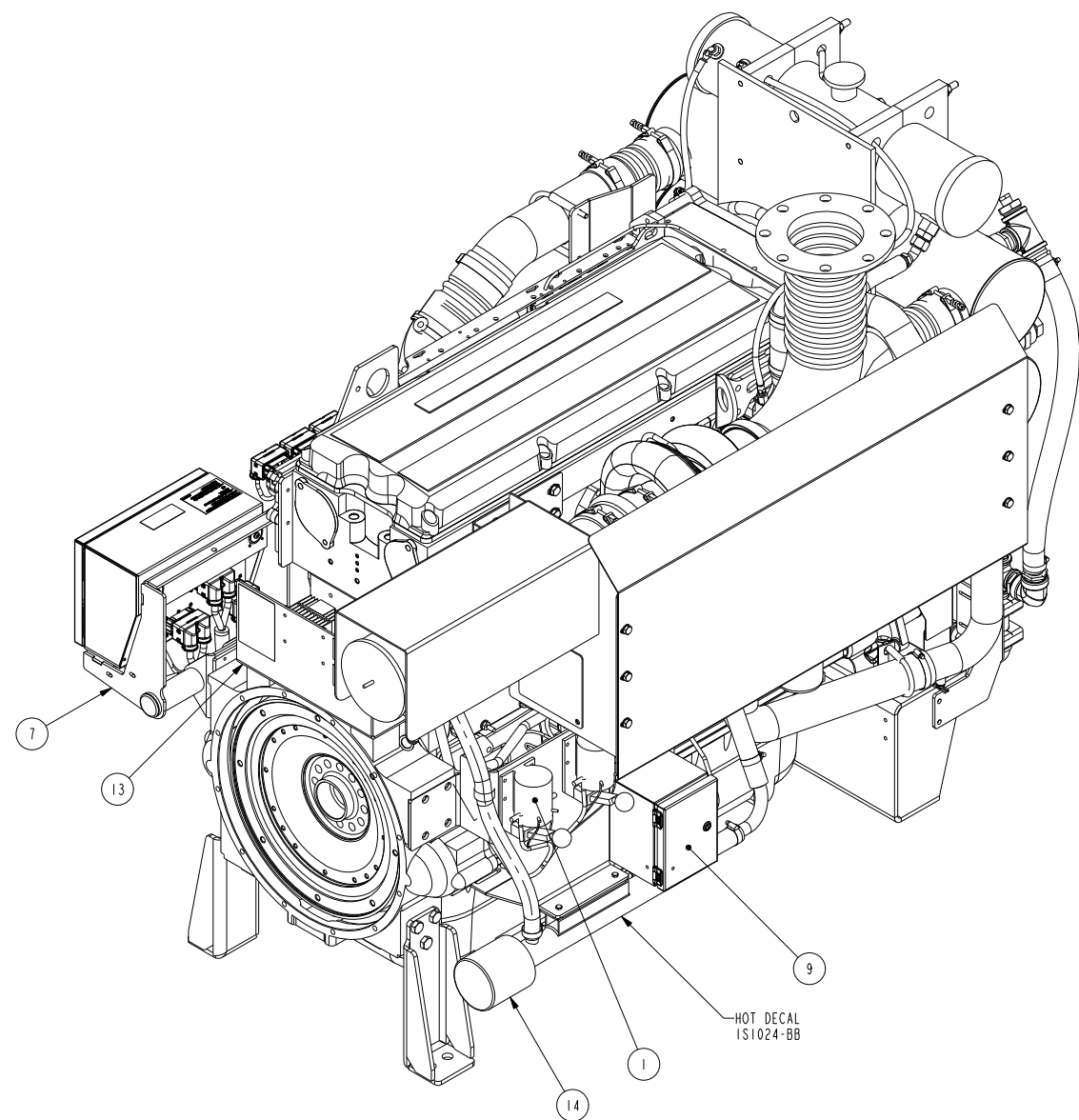

DIMENSIONS ARE IN: INCHES 1: ARE IN:	DO NOT SCALE PRINT SCALE 0.150	CMI DATA CLASSIFICATION Cummins Confidential		Cummins Inc.	
				ITEM NAME ASSEMBLY, FIRE PUMP CFP15E-F70	
DRAWING TOLERANCES APPLY TO PRIMARY DIMENSIONS UNLESS OTHERWISE SPECIFIED F: ± 0.004 IN OR 0.10 mm M: ± 0.003 IN OR 0.075 mm H: ± 0.002 IN OR 0.051 mm H: ± 0.001 IN OR 0.025 mm H: ± 0.0005 IN OR 0.0127 mm H: ± 0.0002 IN OR 0.0051 mm H: ± 0.0001 IN OR 0.0025 mm H: ± 0.00005 IN OR 0.00127 mm H: ± 0.00002 IN OR 0.00051 mm H: ± 0.00001 IN OR 0.00025 mm H: ± 0.000005 IN OR 0.000127 mm H: ± 0.000002 IN OR 0.000051 mm H: ± 0.000001 IN OR 0.000025 mm	FOR INTERPRETATION OF DIMENSIONING AND TOLERANCING, SEE ASME Y14.5-2009	MUST CONFORM TO CES 10903	CAD SHEET 1 OF 3	ITEM NUMBER A042H686	REV 3

REV	REL NO	REVISION	DWN	CKD	APVD	DATE
-	2016-668	RELEASED TO PRODUCTION	HE392	-	-	25OCT16
B	2019-211	SEE SHEET 1 FOR REVISION DETAILS	NO134	MS707	MS707	10MAY19
3	2019-580	SEE SHEET 1 FOR REVISION DETAILS	NO134	MS707	MS707	03DEC19

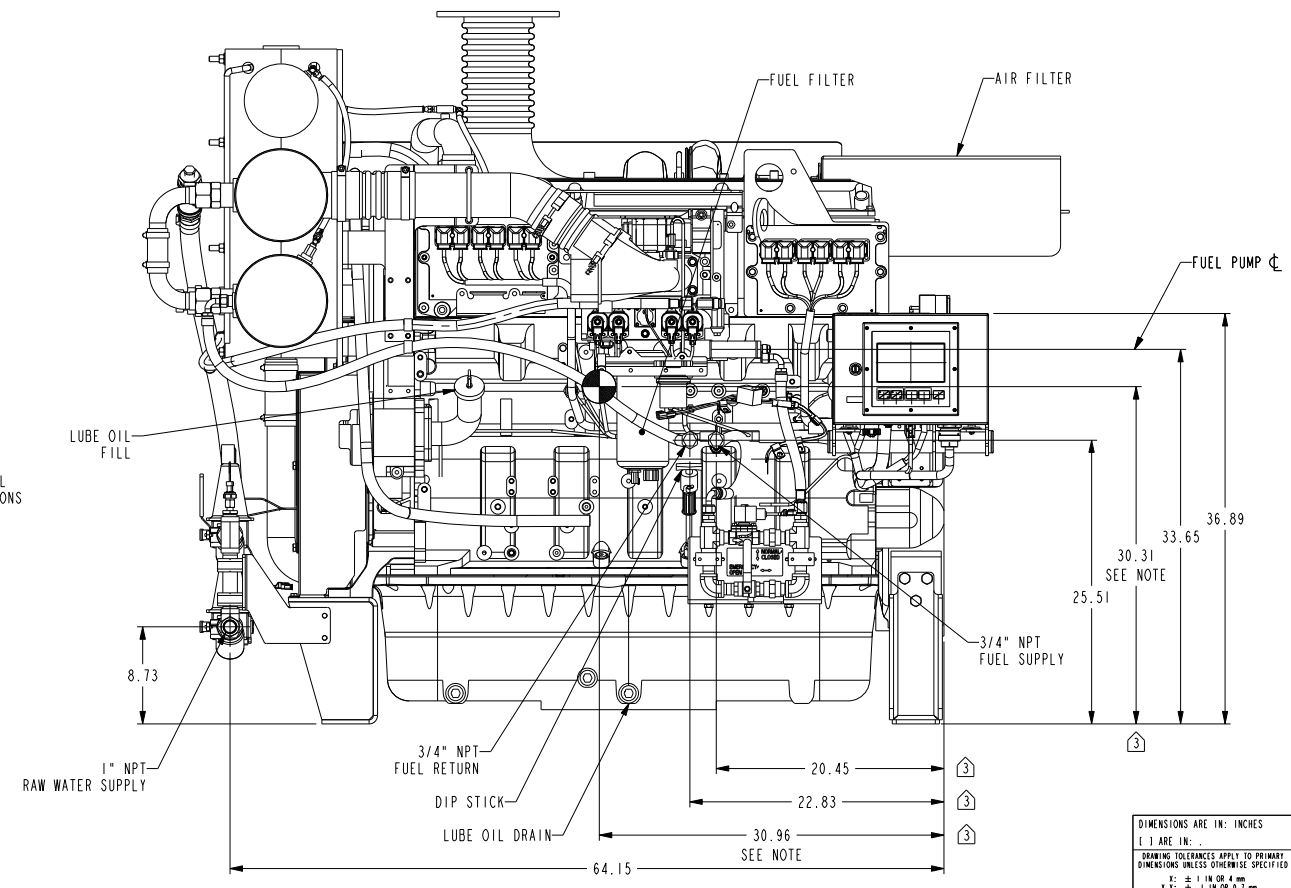
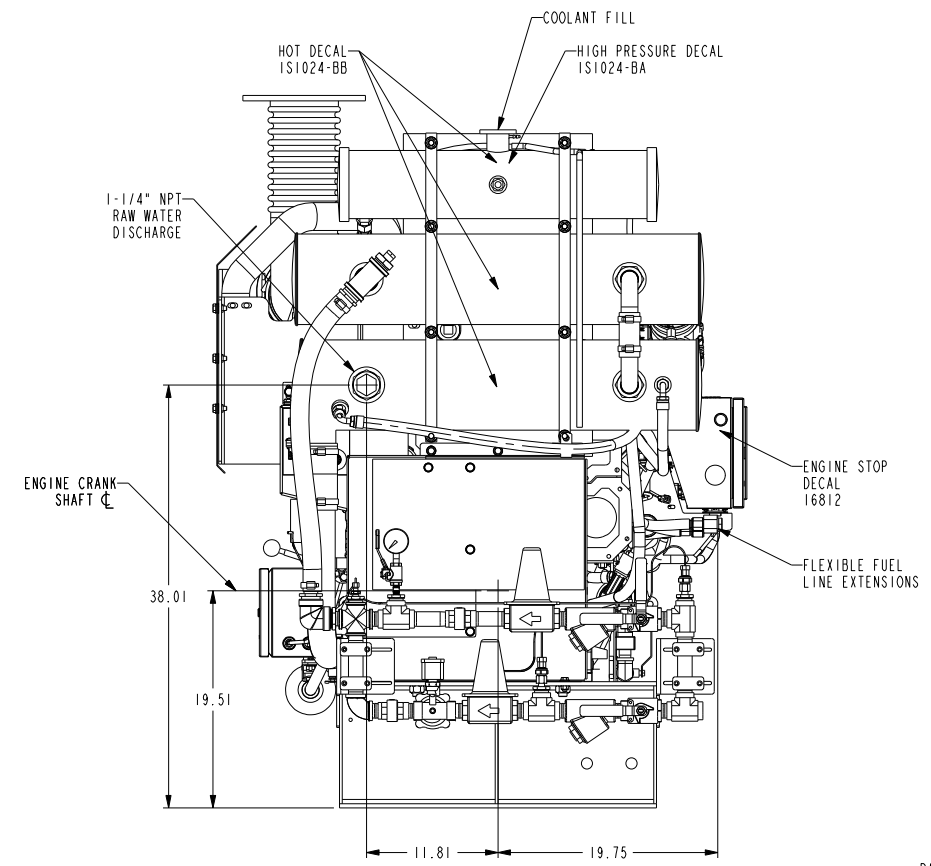
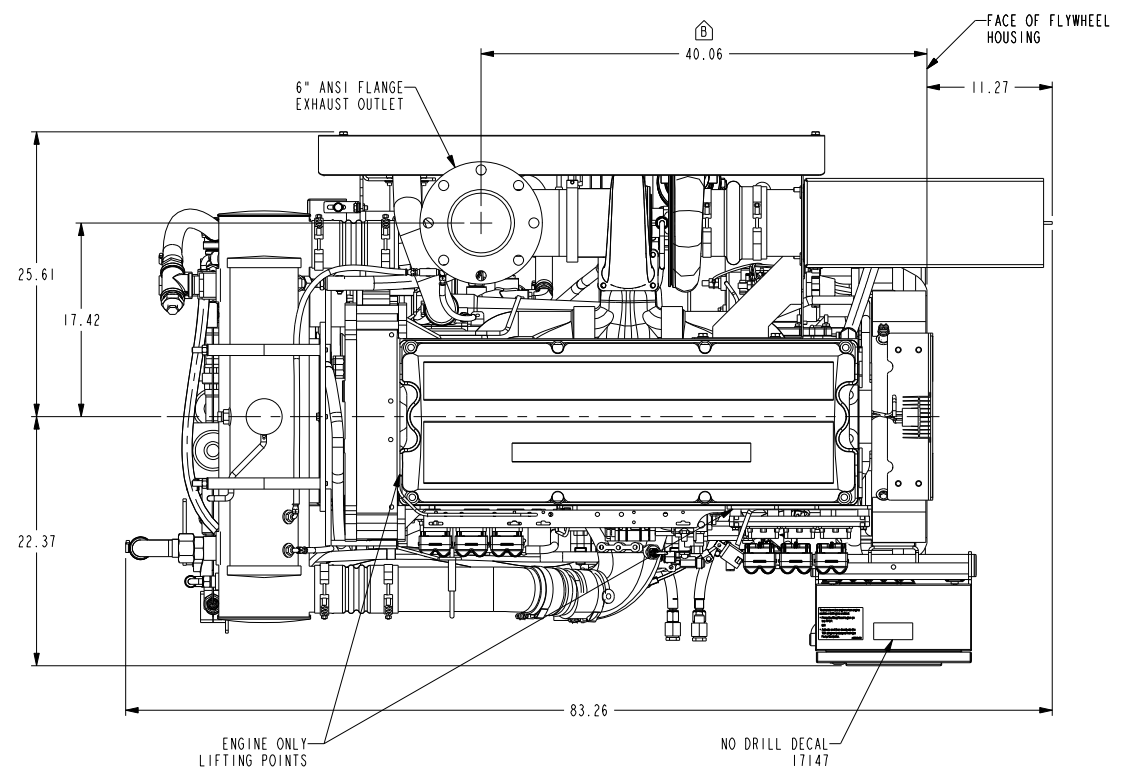

NOTES:
1. CENTER OF GRAVITY LOCATION IS APPROXIMATE

DIMENSIONS ARE IN: INCHES 1. ARE IN: DRAWING TOLERANCES APPLY TO PRIMARY DIMENSIONS UNLESS OTHERWISE SPECIFIED F: ± .0010 IN OR 0.025 mm M: ± .0015 IN OR 0.038 mm A: ± .0010 IN OR 0.025 mm H: ± .0010 IN OR 0.025 mm ANGLE TOLERANCE: ± 1°	DO NOT SCALE PRINT SCALE 0.125	CMI DATA CLASSIFICATION Cummins Confidential DWN: HE392 CKD: HE392 APVD: HE392 DATE: 25OCT2016		Cummins Inc.	
				ITEM NAME ASSEMBLY, FIRE PUMP CFPI5E-F70	
THIS DOCUMENT (AND THE INFORMATION SHOWN THEREON) IS CONFIDENTIAL AND PROPRIETARY AND SHALL NOT BE DISCLOSED TO OTHERS IN ANY MANNER OR BY ANY MEANS, OR REPRODUCED IN ANY MANNER, WITHOUT WRITTEN CONSENT OF CUMMINS INC.			FOR INTERPRETATION OF DIMENSIONING AND TOLERANCING, SEE ASME Y14.5-2009		MUST CONFORM TO CES 10903
CAD SHEET 2 OF 3		ITEM NUMBER A042H686		REV 3	

REV	REL NO	REVISION	DWN	CKD	APVD	DATE
-	2016-668	RELEASED TO PRODUCTION	HE392	-	-	25OCT16
B	2019-211	SEE SHEET 1 FOR REVISION DETAILS	NO134	MS707	MS707	10MAY19
3	2019-580	SEE SHEET 1 FOR REVISION DETAILS	NO134	MS707	MS707	03DEC19

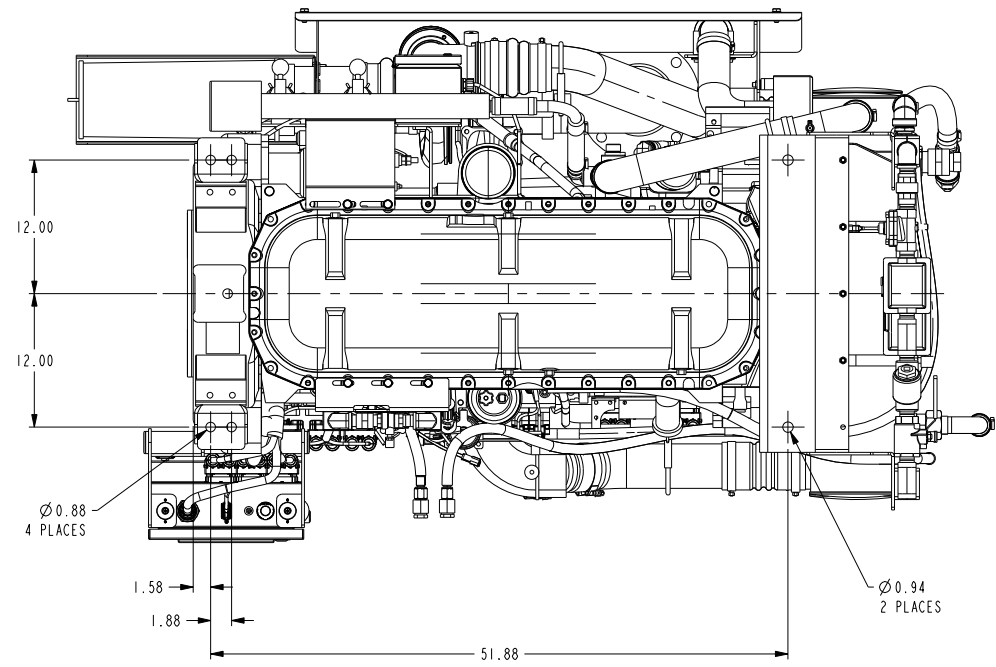
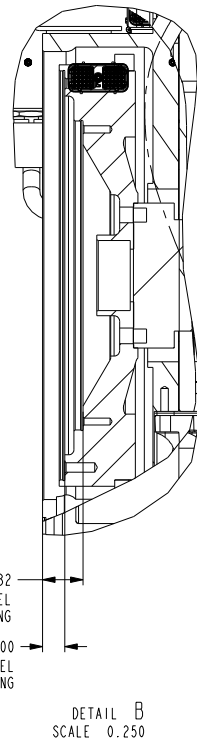
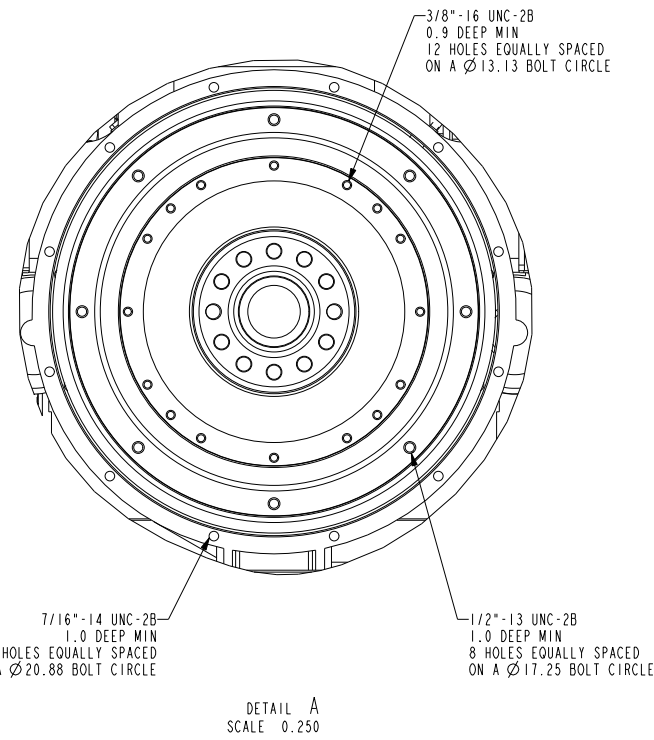
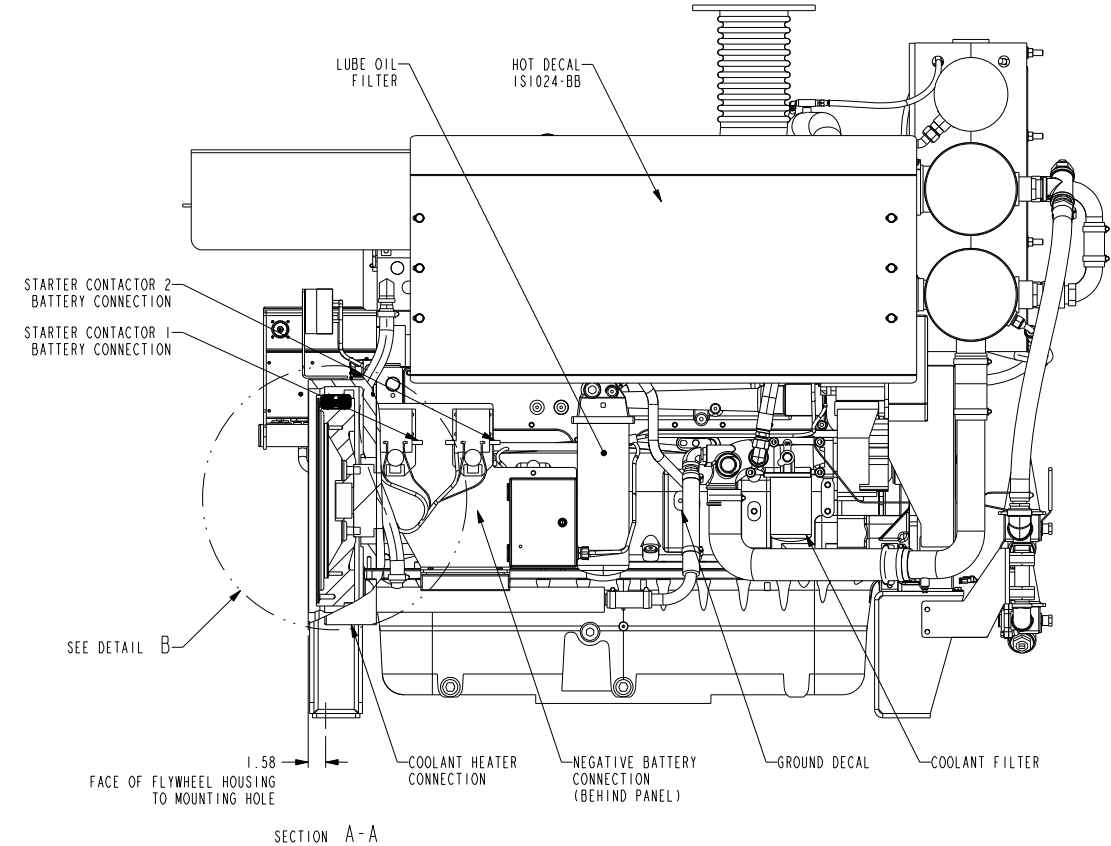
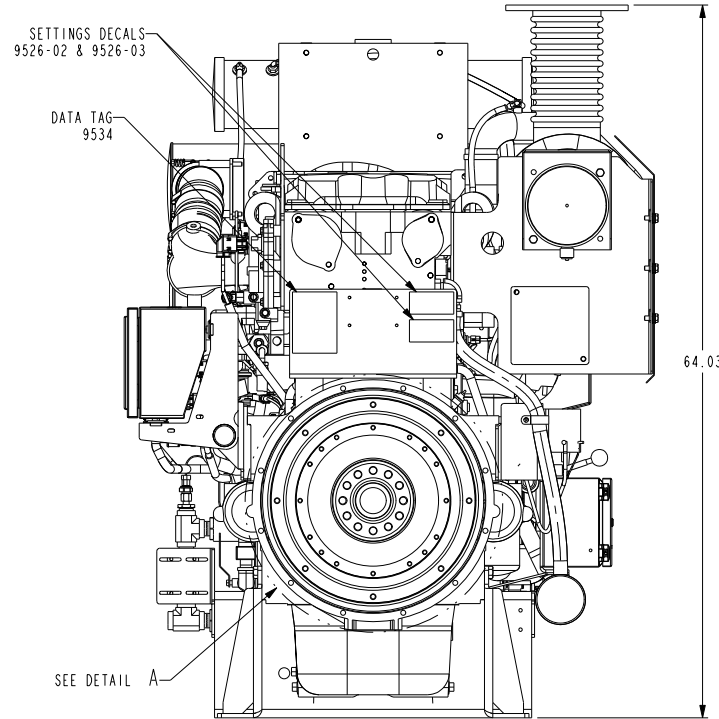

DIMENSIONS ARE IN: INCHES 1.1 ARE IN:	DO NOT SCALE PRINT SCALE 0.125	CMI DATA CLASSIFICATION Cummins Confidential		Cummins Inc.	
				ITEM NAME ASSEMBLY, FIRE PUMP CFP15E-F70	
DRAWING TOLERANCES APPLY TO PRIMARY DIMENSIONS UNLESS OTHERWISE SPECIFIED F: ± .010 IN OR 0.25 mm M: ± .005 IN OR 0.125 mm H: ± .002 IN OR 0.051 mm ANGULAR TOLERANCE: ±	FOR INTERPRETATION OF DIMENSIONING AND TOLERANCING, SEE ASME Y14.5-2009	MUST CONFORM TO CES 10903	CAD SHEET 3 OF 3	ITEM NUMBER A042H686	REV 3

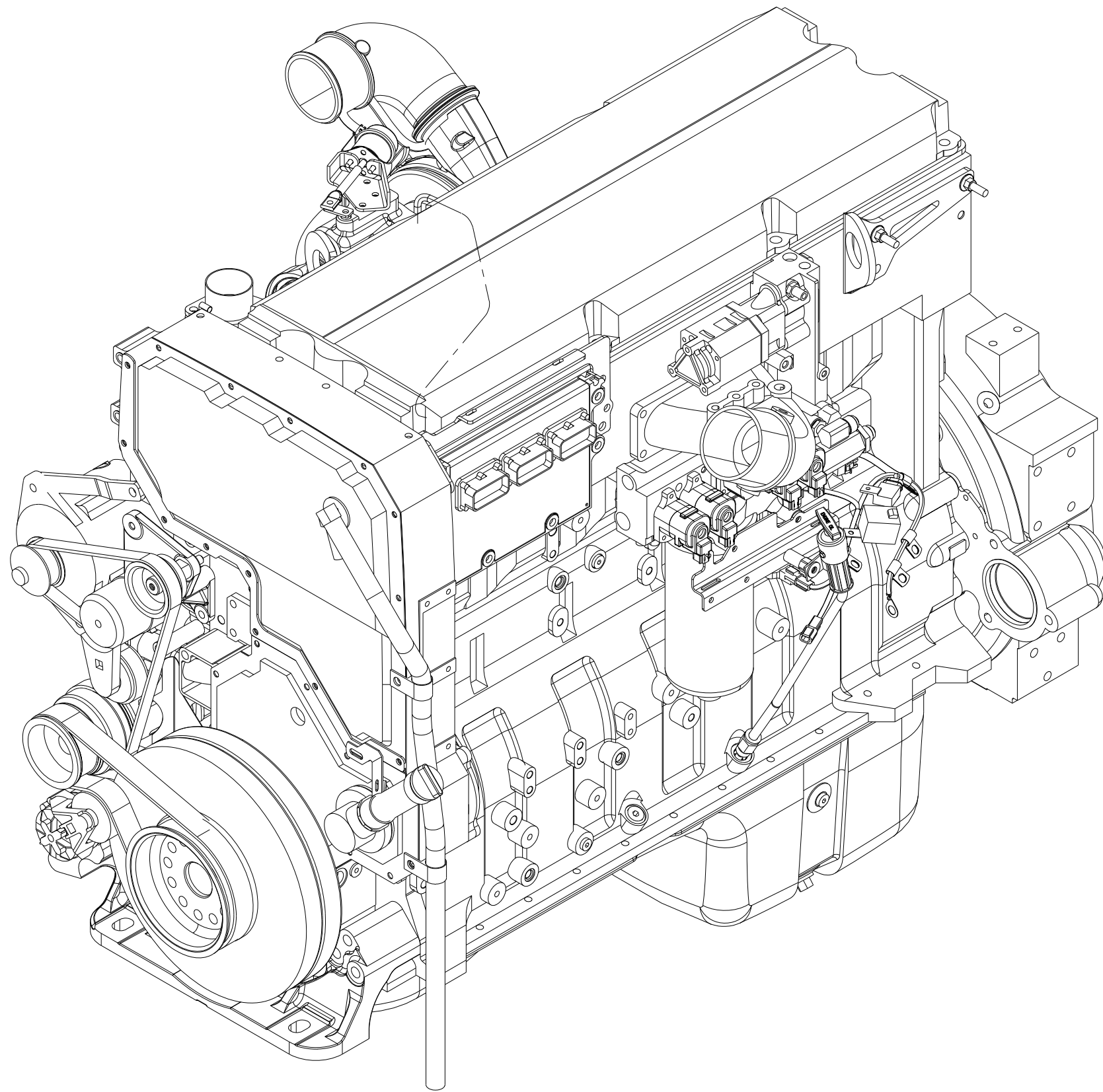

BILL OF MATERIAL							
ITEM	QTY	DESCRIPTION	PART NUMBER				
1	1	SUPPORT, ACCESSORY	AB1702	31	1	MOUNTING, INT CONNECTION	IC1712
2	1	APPROVAL, AGENCY	AP1214	32	1	CONNECTION, AIR TRANSFER	IT1014
3	1	PLUMBING, CYLINDER BLOCK	BB1819	33	1	ARRANGEMENT, LIFTING	LA1099
4	1	BLOCK, CYLINDER	BB1898	34	1	COOLER, ENGINE OIL	LC1734
5	1	BREATHER, CRANKCASE	BR1242	35	1	OIL FILTER	LF1210
6	1	DRIVE, ENGINE BARRING	CB1707	36	1	GAUGE, OIL LEVEL	LG1035
7	1	MOUNTING, REF COMPRESSOR	CF1069	37	1	PUMP, LUBRICATING OIL	LP1718
8	1	AID, COO HEATER STARTING	CH1021	38	1	LITERATURE	LT1066
9	1	DAMPER, VIBRATION	DA1229	39	1	NAMEPLATE	NN1701
10	1	DRIVE, FRO GER TRA ACC	DF1020	40	1	FILL, OIL	OB1400
11	1	LOCATION, DRAIN	DL1047	41	1	MOUNTING, OIL FILL TUBE	OB1723
12	1	SOFTWARE, CUSTOMER INTERFACE	DO1482	42	1	PAN, OIL	OP1489
13	1	HARNES, EXTENSION	EA1715	43	1	MODULE, ENGINE CONTROL	PH1763
14	1	ENGINE BRAKE, NONE	EB1203	44	1	TURBOCHARGER	PP10303
15	1	THERMOSTAT	EC1722	45	1	PARTS, PERFORMANCE	PP43087
16	1	ALTERNATOR	EE1269	46	1	POWER, PROGRAMMABLE	PW1157
17	1	MOUNTING, ALTERNATOR	EH1102	47	1	SOFTWARE, CALIBRATION	SC11533
18	1	DRIVE, ALTERNATOR	EH1730	48	1	ARRANGEMENT, SHIPPING	SK1001
19	1	SUPPORT, FRONT ENGINE	EM1397	49	1	BRACKET, SHIPPING	SK1709
20	1	FAN DRIVE, NONE	FA1464	50	1	MOUNTING, STARTER MOTOR	SM1742
21	1	CALIBRATION, FUEL PUMP	FCPJ30	51	1	PAINT	SS1097
22	1	FILTER, FUEL	FF1280	52	1	MOTOR, STARTING	ST1408
23	1	HOUSING, FLYWHEEL	FH11089	53	1	VOLTAGE, ENGINE OPERATION	SV1002
24	1	PUMP, FUEL	FP11065	54	1	ARRANGEMENT, TURBOCHARGER	TB1453
25	1	RATING, FUEL	FR10663	55	1	HOUSING, THERMOSTAT	TH1160
26	1	FLYWHEEL	FW1022	56	1	COVER, VALVE	VC1072
27	1	MOUNTING, FLYWHEEL	FW1701	57	1	RESISTOR, CORROSION	WF1241
28	1	COVER, FRONT GEAR	GG1729	58	1	CONNECTION, WATER INLET	WI1087
29	1	AIR INTAKE CONNECTION OPTION, 35 DEG UP	IC1057	59	1	CONNECTION, WATER OUTLET	WO1123
30	1	HOSES, AIR INTAKE	IC1080	60	1	PUMP, WATER	WP1750
				61	1	CONNECTION, EXHAUST OUTLET	XS1026

This document contains confidential and trade secret information, is the property of Cummins Fire Power LLC and is given to the receiver in confidence. The receiver, by receiving and retaining of the document accepts the document in confidence and agrees that, except as authorized in writing by Cummins Fire Power, it will (1) not use the document or any copy thereof of the confidential or trade secret information therein, (2) not copy the document, (3) not disclose to others either the document or the confidential or trade secret information therein, and (4) upon completion of the need to retain the document, or upon demand, return the document, all copies thereof, and all material copied therefrom. COPYRIGHT Cummins Fire Power LLC



CUMMINS FIRE POWER LLC
CORPORATE OFFICE
1600 BUEKLE ROAD
WHITE BEAR LAKE, MN
WWW.CUMMINSFIREPOWER.COM

CUSTOM DESIGN
AND UFIT CENTER
875 LAWRENCE DRIVE
DEPERE, WISCONSIN

ENGINE, QSX15-C665
SPEC CFP15E F10-F40

ANGULAR DIMENSIONS ± 1°

THIRD ANGLE PROJECTION

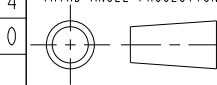

MACHINED SURFACES

125

IMPERIAL UNITS

METRIC UNITS

MACHINING TOLERANCES

FORM TOLERANCES

FAB TOLERANCES

DWG UNITS:

MM KG S

SCALE: 0.150

EST WEIGHT: 3253.111

DRAWN BY: S.DANFORTH

PRO-ENGINEER

SHEET 1 OF 1

DATE: APR2006

INIT ECO: 8742

REV	ECO	DESCRIPTION OF REVISION	REV BY	DATE
E	2014-679	SPEC UPDATED	JJW	29SEP2014
D	2010-367	SPEC UPDATE	S DUBICK	10AUG2010

C B		BILL OF MATERIAL							
ITEM	QTY	DESCRIPTION	PART NUMBER						
1	1	SUPPORT, ACCESSORY	AB1701	21	1	FILTER, FUEL			FF1254
2	1	APPROVAL, AGENCY	API186	22	1	HOUSING, FLYWHEEL			FH11089
3	1	DOCUMENTATION, DCN IPN	API704	23	1	PUMP, FUEL			FP11065
4	1	PLUMBING, CYLINDER BLOCK	BB1809	24	1	RATING, FUEL			FR10549
5	1	BLOCK, CYLINDER, QSX15	BB1888	25	1	FLYWHEEL			FW1022
6	1	COMPONENTS, BASE	BC1006	26	1	MOUNTING, FLYWHEEL			FW1701
7	1	BREATHER, CRANKCASE	BR1252	27	1	COVER, FRONT GEAR			GG1727
8	1	ADAPTER, PUMP DRIVE, CECO OPTION, UPFIT BY CFP	CB1704	28	1	CONNECTION, AIR INTAKE, REPLACE WITH IC1057			IC1064
9	1	AID, COO HEATER STARTING	CH1021	29	1	HOSE, AIR INTAKE			IC1071
10	1	DAMPER, VIBRATION	DA1229	30	1	MOUNTING, INT CONNECTION			IC1712
11	1	LOCATION, DRAIN	DL1047	31	1	CONNECTION, AIR TRANSFER			IT1022
12	1	SOFTWARE, CUSTOMER INTERFACE	DO1512	32	1	ARRANGEMENT, LIFTING			LA1094
13	1	HARNES, EXTENSION	EA1705	33	1	COOLER, ENGINE OIL			LC1729
14	1	THERMOSTAT	EC1722	34	1	OIL FILTER			LF1210
15	1	ALTERNATOR	EE1211	35	1	OIL LEVEL GAUGE			LG1090
16	1	MOUNTING, ALTERNATOR	EH1099	36	1	PUMP, LUBRICATING OIL			LP1709
17	1	DRIVE, ALTERNATOR	EH1723	37	1	LITERATURE			LT1070
18	1	SUPPORT, FRONT ENGINE	EM1356	38	1	NAMEPLATE			NN1701
19	1	FAN DRIVE, NONE	FA1464	39	1	ARRANGEMENT, OIL FILL			OB1397
20	1	CALIBRATION, FUEL PUMP	FCPG25	40	1	PAN, OIL			OPI493
				41	1	MODULE, ENGINE CONTROL			PH1807
				42	1	PARTS, PERFORMANCE			PP8587
				43	1	POWER, PROGRAMMABLE			PW1112
				44	1	PLUMBING, RADIATOR			RP1003
				45	1	SOFTWARE, CALIBRATION			SC11593
				46	1	ARRANGEMENT, SHIPPING			SK1018
				47	1	BRACKET, SHIPPING			SK1705
				48	1	MOUNTING, STARTER MOTOR			SM1742
				49	1	PAINT			SS1097
				50	1	MOTOR, STARTING			ST1408
				51	1	ARRANGEMENT, TURBOCHARGER			TB1410
				52	1	HOUSING, THERMOSTAT			TH1156
				53	1	PLUMBING, TURBOCHARGER			TP1756
				54	1	COVER, VALVE			VC1072
				55	1	RESISTOR, CORROSION			WF1241
				56	1	CONNECTION, WATER INLET			WI1076
				57	1	PUMP, WATER			WP1733
				58	1	CONNECTION, EXHAUST OUTLET			XS1069

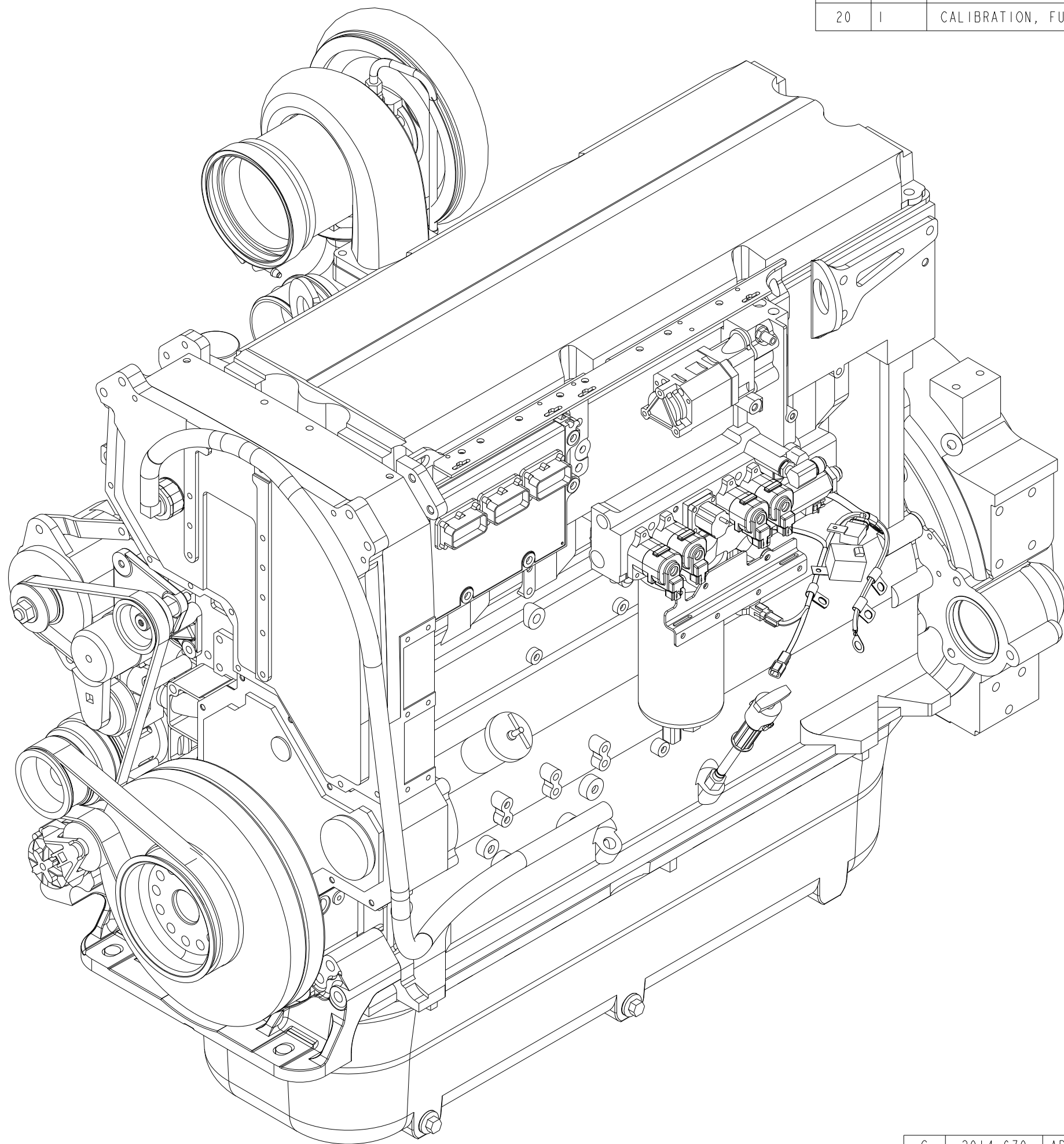

This document contains confidential and trade secret information, is the property of Cummins Fire Power LLC and is given to the receiver in confidence. The receiver, by receiving and retaining of the document accepts the document in confidence and agrees that, except as authorized in writing by Cummins Fire Power, it will not use the document or any copy thereof of the confidential or trade secret information therein, (2) not copy the document, (3) not disclose to others either the document or the confidential or trade secret information therein, and (4) upon completion of the need to retain the document, or upon demand, return the document, all copies thereof, and all material copied therefrom. COPYRIGHT Cummins Fire Power LLC

	CUMMINS FIRE POWER LLC CORPORATE OFFICE 1600 BUEKLE ROAD WHITE BEAR LAKE, MN WWW.CUMMINSFIREPOWER.COM	CUSTOM DESIGN AND UPFIT CENTER 875 LAWRENCE DRIVE DEPERE, WISCONSIN
	ENGINE, QSX15-G9-755 SPEC CFP15 F50-F70	

UNLESS OTHERWISE SPECIFIED ALL DIMENSION TOLERANCES ARE:		MACHINED SURFACES		IMPERIAL UNITS	METRIC UNITS	DWG UNITS:	DRAWN BY: S.DANFORTH	DATE: APR2006
ANGULAR DIMENSIONS ± 1°				± .005	± .02	MM KG S	PRO-ENGINEER	INIT ECO:
THIRD ANGLE PROJECTION				± .005	± .02	SCALE: 0.166	SHEET 1 OF 1	DRAWING NO: 11712
				± .005	± .02	EST WEIGHT: 1475.164		

C	2014-679	API186 REPLACED API179	JJW	26SEP2014
B	2010-367	SPEC UPDATED	S DUBICK	10AUG2010
REV	ECO	DESCRIPTION OF REVISION	REV BY	DATE

ITEM	QTY	DESCRIPTION	PART NUMBER
1	1	COOLER, JACKET WATER; CFP15E	10847
2	1	HEAT EXCHANGER, CAC; CFP15E	10848
3	1	TUBE, COOLANT, LOWER; CFP15E	10891
4	1	TUBE, COOLANT, UPPER; CFP15E FIREPUMP	10892
5	1	TUBE, CAC, TURBO SIDE; CFP15E FIREPUMP	10893
6	1	TUBE, CAC, IM SIDE; CFP15E FIREPUMP	10894
7	1	HOSE, WATER FILL; CFP15E	12950
8	1	DRAIN VALVE, 1/4"NPT; DC604-4	80511
9	1	BRACKET, HEAT EXCHANGER ; CFP15E	A058V256
10	1	BRACKET, MOUNTING; HEAT EXCHANGER	A059H839
11	16	COOLANT, FC EG PM, 1 GALLON	CC2743
12	1	ADAPTER, MALE JIC 37 DEG X MALE SAE ORB; -12	12235-12-12
13	1	TANK, SURGE; CFP15E, FIREPUMP	10865
14	1	DETAIL, BRKT, HX MOUNTING; CFP15E FIREPUMP	11487
15	4	BRACKET, HEAT EXCHANGER MOUNTING; BACK	11488
16	1	BRACKET, RADIATOR TUBE	11581
17	1	CONNECTOR, FEMALE; -6 ORB X -4 FNPT, STEEL	12171-6-4
18	1	CONNECTOR, FEMALE; M12 ORR X -4 FNPT, STEEL	12181-M12-4
19	1	PLUG, PIPE; INT HEX -2 NPT, STEEL	12212-2
20	1	TEE, MALE BRANCH PIPE; -4 NPT, BRASS	12533-4
21	6	COUPLING, PLAIN HOSE; -4 FLR X -4 BARB, STEEL	12543-4-4
22	3	ELBOW, MALE ADAPTER; 90D -4 FLR X -4 NPT, BRS	12550-4-4
23	1	ELBOW, MALE ADAPTER; 45D -4 FLR X -4 NPT, BRS	12551-4-4
24	2	CONNECTOR, MALE; -4 FLR X -4 NPT, BRASS	12553-4-4
25	8	ROD, 1/2-13 X 12; 1-1/2" THREADED ENDS	12791
26	1	BRACKET, CAC SUPPORT; CFP15E LOW HORSE POWER	12886
27	2	CLAMP, SPRING LOADED T-BOLT; 4.28-4.58	12975-0450
28	1	CLAMP, HOSE; .56-1.06 WORM	14990-10
29	8	CLAMP, HOSE; 2.06 - 3.00 WORM	14990-40
30	8	WASHER, PLAIN; 0.50, B18.21.1 TYPE A, NRW	20010-050
31	8	NUT, HEX; 0.50-13	20100-050
32	1	HOSE, RUBBER, 2.50 90 DEGREE; GATES 21891	21891
33	1	CLIP; 1.25 ID, 3/8" HOLE, VINYL	26963-20
34	1	HOSE, FUEL LINE, 5/16ID; 72"L	27003
35	1	VALVE, CHECK	3970799
36	1	ELBOW, 90 DEG, JIC X METRIC PORT; PARKER OR EQUIV.	12275-12-M27
37	1	SIGHT GLASS, 1/2" NPT	3277K34
38	1	CLAMP, U-BOLT; NELSON	89543K
39	4	CLAMP, U-BOLT; GUILLOTINE; 4.00", PLATED	89548K
40	2	HOSE, PLAIN; 2.50 ID X 6.00 LG EPDM	A042F057
41	1	HOSE, SILICONE; 5/8IN ID X 42.00IN LONG	A042F072
42	1	BRACKET, CAC, IM SIDE; CFP15E FIREPUMP	A042F177
43	1	HOSE, COOLANT, RUBBER; GATES, 2.50 I.D. 90 DEGREE	21115
44	1	HOSE, PARKER; 1/4IN ID X 12.00IN LONG	R-801-4
45	1	HOSE, PARKER; 1/4IN ID X 14.00IN LONG	R-801-4
46	1	HOSE, PARKER; 1/4IN ID X 18.00IN LONG	R-801-4

REV	REL NO	REVISION	DWN	CKD	APVD	DATE
AA	2018-705	ADDED A058V256 & A059H839; DELETED DIMENSION VIEWS, 11486, 4330737, 12975-0425, IC1080 & HARDWARE; UPDATED DRAWING TITLE & NOTES; A042F057 REPLACED 8933 (QTY 2) & 89548K (QTY 4) WAS 5	L0629	MS707	MS707	04JAN19
28	2020-048	UPDATED PER 10891; ADDED 80511; REMOVED 16825	RE123	MS707	MS707	23JAN20
29	2020-057	UPDATED PER 10848, 10865 & HOSE LENGTH; ADDED 3970799, 14990-10 & A042F072	NO134	MS707	MS707	14MAY20

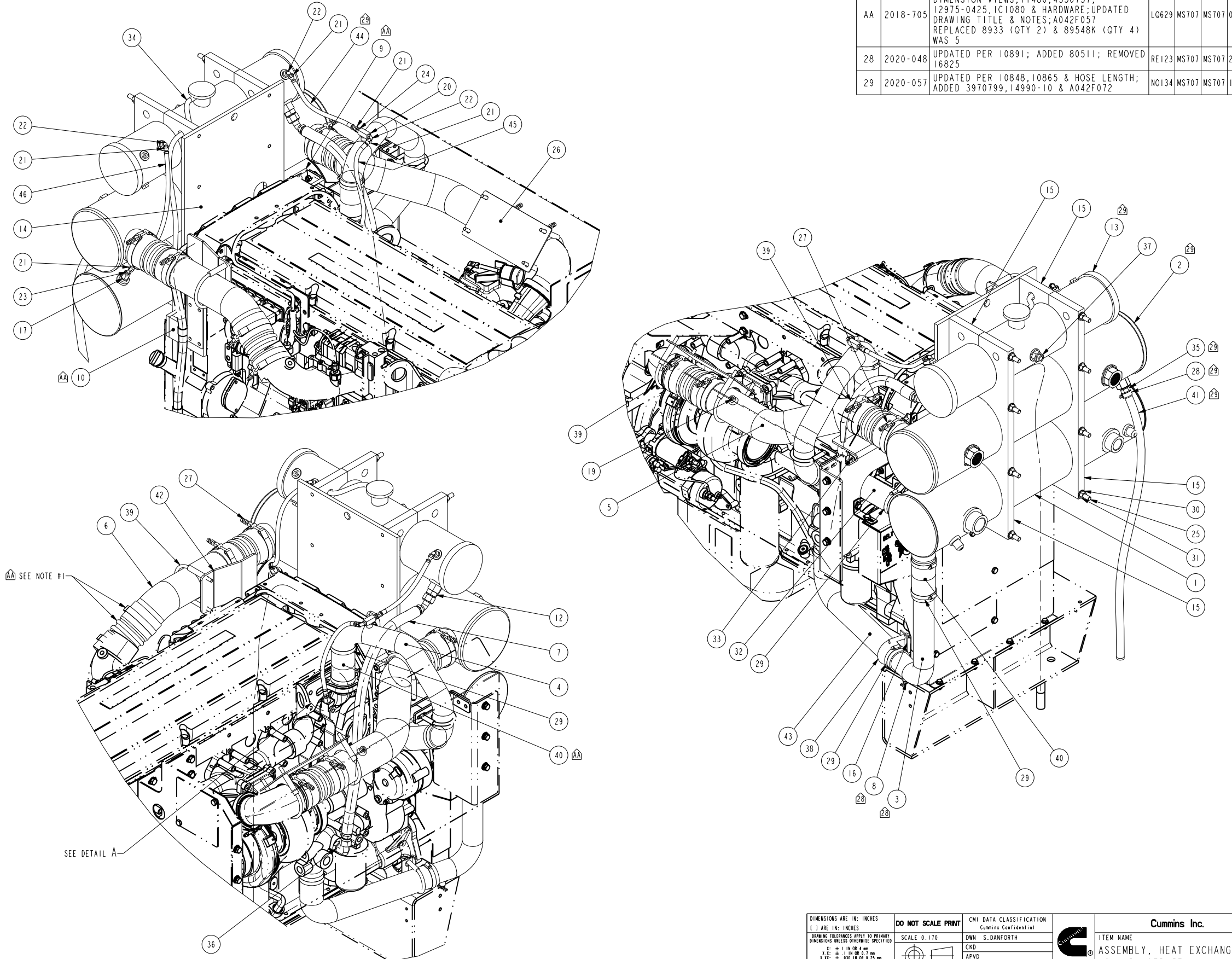

NOTES:
 1. CAC HUMP HOSES QTY(4) & CLAMPS QTY(8) COME W/ ENGINE
 2. ALL FITTINGS TO BE POSITIONED AS SHOWN
 3. ALL PARTS TO BE CLEAN BEFORE ASSEMBLY
 4. ALL OPENINGS ARE TO BE CAPPED OR PLUGGED AFTER ASSEMBLY
 5. CHECK ALL FITTINGS FOR O-RING BEFORE MAKING CONNECTIONS
 6. APPLY THREAD SEALANT ON ALL NPT THREADS

DIMENSIONS ARE IN: INCHES 1: ARE IN: INCHES	DO NOT SCALE PRINT	CMV DATA CLASSIFICATION Cummins Confidential		Cummins Inc.	
DRAWING TOLERANCES APPLY TO PRIMARY DIMENSIONS UNLESS OTHERWISE SPECIFIED	SCALE 0.170	DWN: S.DANFORTH		ITEM NAME ASSEMBLY, HEAT EXCHANGER LOW HP, CFP15E	
F: ± .10 IN OR 3 mm M: ± .01 IN OR .25 mm H: ± .005 IN OR .125 mm A: ± .010 IN OR .25 mm ANGULAR TOLERANCE: ±		CKD: APVD: DATE: 25 JUN 2007	MUST CONFORM TO CES 10903	CAD SHEET 1 OF 1	ITEM NUMBER 11492-01
THIS DOCUMENT (AND THE INFORMATION SHOWN THEREON) IS CONFIDENTIAL AND PROPRIETARY AND SHALL NOT BE DISCLOSED TO OTHERS IN HARD COPY OR ELECTRONIC FORM, REPRODUCED BY ANY MEANS, OR USED FOR ANY PURPOSE WITHOUT WRITTEN CONSENT OF CUMMINS INC.			FOR INTERPRETATION OF DIMENSIONING AND TOLERANCING, SEE ASME Y14.5-2009	REV 29	

BILL OF MATERIAL			
ITEM	QTY	DESCRIPTION	PART NUMBER
1	1	TUBE, COOLANT, LOWER; CFP15E	10891
2	1	TUBE, COOLANT, UPPER; CFP15E FIREPUMP	10892
3	1	TUBE, CAC, TURBO SIDE; CFP15E FIREPUMP	10893
4	1	TUBE, CAC, IM SIDE; CFP15E FIREPUMP	10894
5	1	HOSE, WATER FILL; CFP15E	12950
6	1	HEAT EXCHANGER, JW, 8" DIA; COPPER NICKEL, CFP15E	15725
7	1	HEAT EXCHANGER, CAC, 8" DIA; COPPER NICKEL, CFP15E	15726
8	1	GROUND STRAP, 1/4" BRAID; 12" LONG, 1/4" & 1/2" TERMINALS	15813
9	1	GROUND STRAP, 1/4" BRAID; 18" LONG, 1/4" & 1/2" TERMINALS	15814
10	1	DRAIN VALVE, 1/4"NPT; DC604-4	80511
11	1	BRACKET, HEAT EXCHANGER ; CFP15E	A058V256
12	1	BRACKET, MOUNTING; HEAT EXCHANGER	A059H839
13	1	ADAPTER, MALE JIC 37 DEG X MALE SAE ORB; -12	12235-12-12
14	1	TANK, SURGE; CFP15E, FIREPUMP	10865
15	1	DETAIL, BRKT, HX MOUNTING; CFP15E FIREPUMP	11487
16	4	BRACKET, HEAT EXCHANGER MOUNTING; BACK	11488
17	1	BRACKET, RADIATOR TUBE	11581
18	1	CONNECTOR, FEMALE; -6 ORB X -4 FNPT, STEEL	12171-6-4
19	1	CONNECTOR, FEMALE; M12 ORR X -4 FNPT, STEEL	12181-M12-4
20	1	TEE, MALE BRANCH PIPE; -4 NPT, BRASS	12533-4
21	6	COUPLING, PLAIN HOSE; -4 FLR X -4 BARB, STEEL	12543-4-4
22	3	ELBOW, MALE ADAPTER; 90D -4 FLR X -4 NPT, BRS	12550-4-4
23	1	ELBOW, MALE ADAPTER; 45D -4 FLR X -4 NPT, BRS	12551-4-4
24	2	CONNECTOR, MALE; -4 FLR X -4 NPT, BRASS	12553-4-4
25	8	ROD, 1/2-13 X 12; 1-1/2" THREADED ENDS	12791
26	1	BRACKET, CAC SUPPORT; CFP15E LOW HORSE POWER	12886
27	2	CLAMP, SPRING LOADED T-BOLT; 4.28-4.58	12975-0450
28	1	CLAMP, HOSE; .56-1.06 WORM	14990-10
29	8	CLAMP, HOSE; 2.06 - 3.00 WORM	14990-40
30	8	NUT, HEX; 0.50-13	20100-050
31	1	HOSE, RUBBER, 2.50 90 DEGREE; GATES 21891	21891
32	1	CLIP; 1.25 ID, 3/8" HOLE, VINYL	26963-20
33	1	HOSE, FUEL LINE, 5/16ID; 72"L	27003
34	1	VALVE, CHECK	3970799
35	1	ELBOW, 90 DEG, JIC X METRIC PORT; PARKER OR EQUIV.	12275-12-M27
36	1	SIGHT GLASS, 1/2" NPT	3277K34
37	1	CLAMP, U-BOLT; NELSON	89543K
38	4	CLAMP, U-BOLT, GUILLOTINE; 4.00", PLATED	89548K
39	2	HOSE, PLAIN; 2.50 ID X 6.00 LG EPDM	A042F057
40	1	HOSE, SILICONE; 5/8IN ID X 42.00IN LONG	A042F072
41	1	BRACKET, CAC, IM SIDE; CFP15E FIREPUMP	A042F177
42	16	COOLANT, FC EG PM, 1 GALLON; -	CC2743
43	1	HOSE, COOLANT, RUBBER; GATES, 2.50 I.D. 90 DEGREE	21115
44	1	HOSE, PARKER; 1/4IN ID X 12.00IN LONG	R-801-4
45	1	HOSE, PARKER; 1/4IN ID X 14.00IN LONG	R-801-4
46	1	HOSE, PARKER; 1/4IN ID X 18.00IN LONG	R-801-4

REV	REL NO	REVISION	DWN	CKD	APVD	DATE
-	2014-757	RELEASED TO PRODUCTION	PBS		JT	04NOV14
6	2020-048	ADDED 80511 (1); UPDATED PER 10891	RE123	MS707	MS707	23JAN20
7	2020-057	UPDATED PER 10865, 15726 & HOSE LENGTH; ADDED 3970799, 14990-10 & A042F072	N0134	MS707	MS707	15MAY20

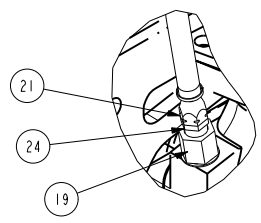
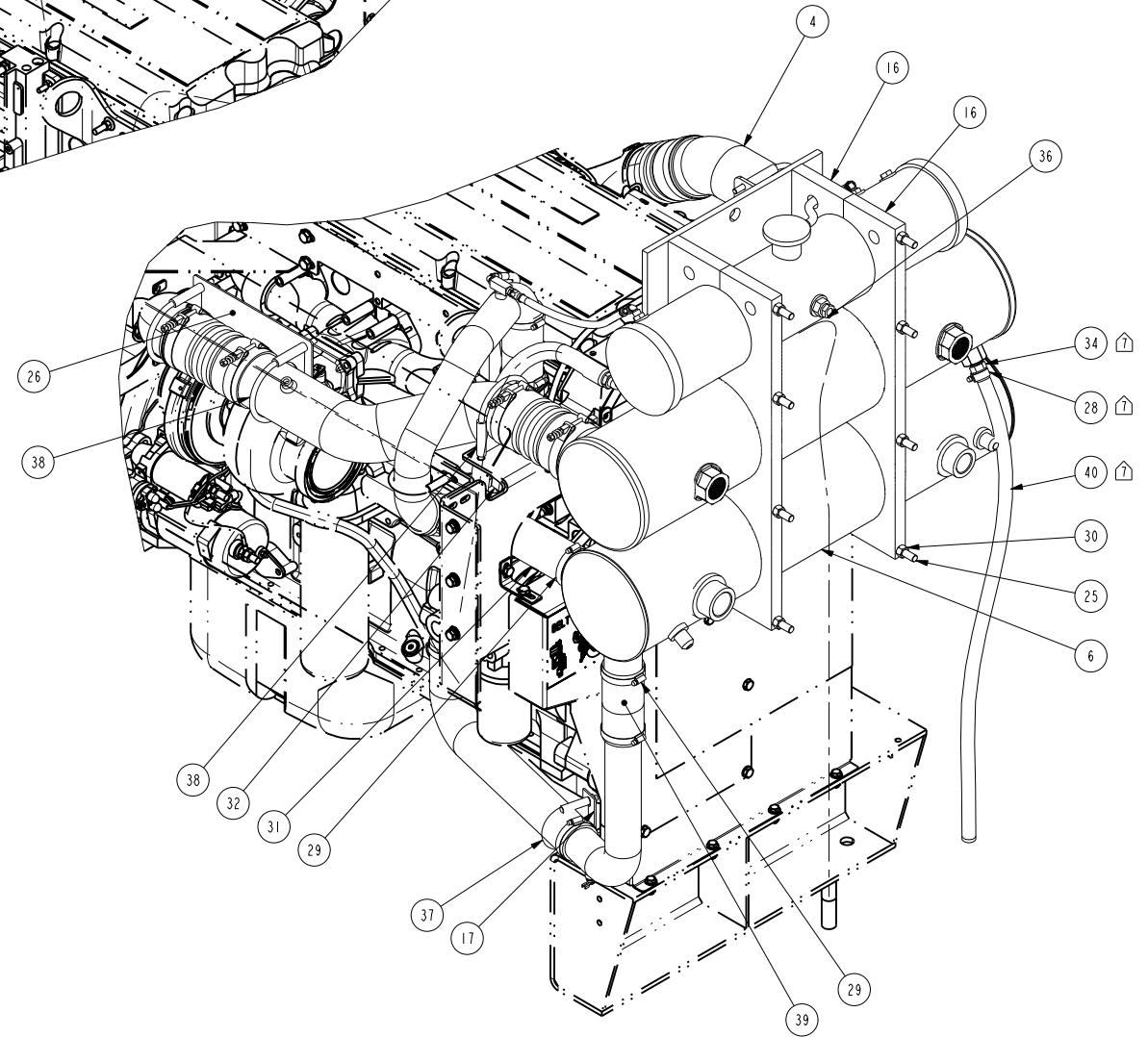
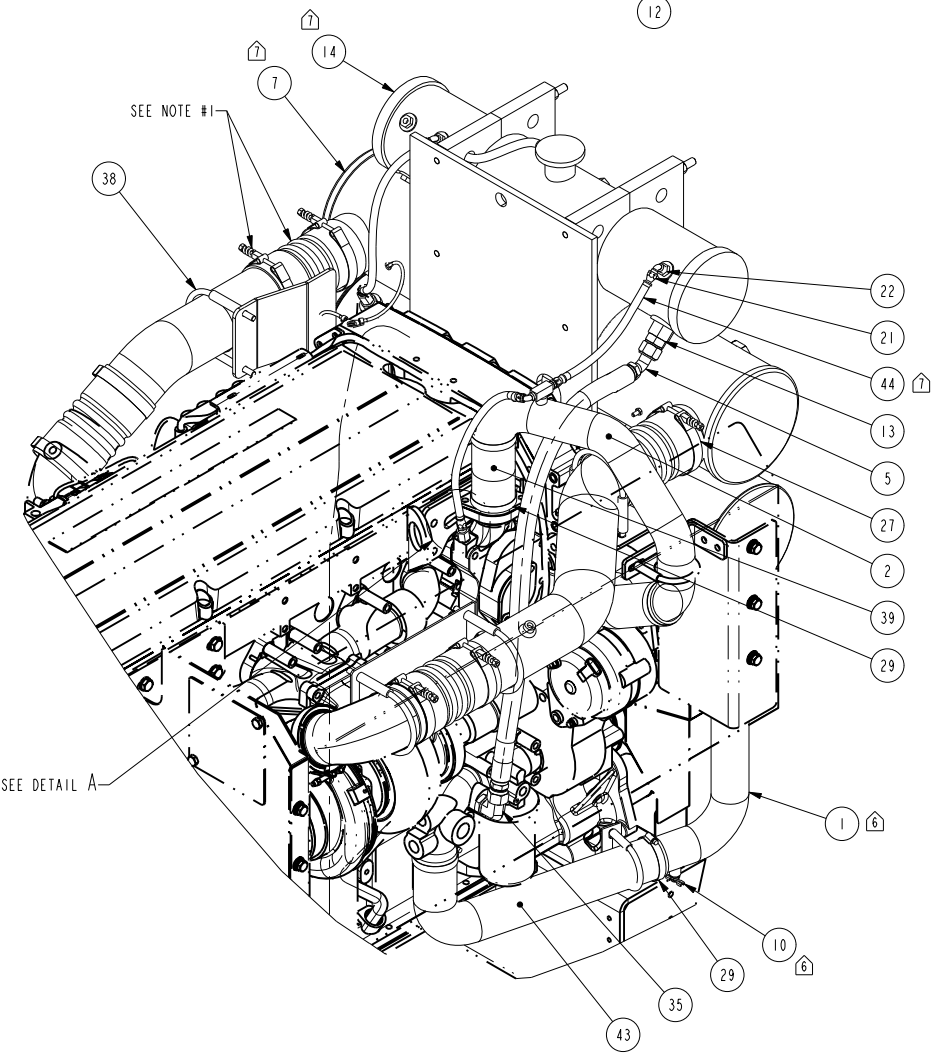
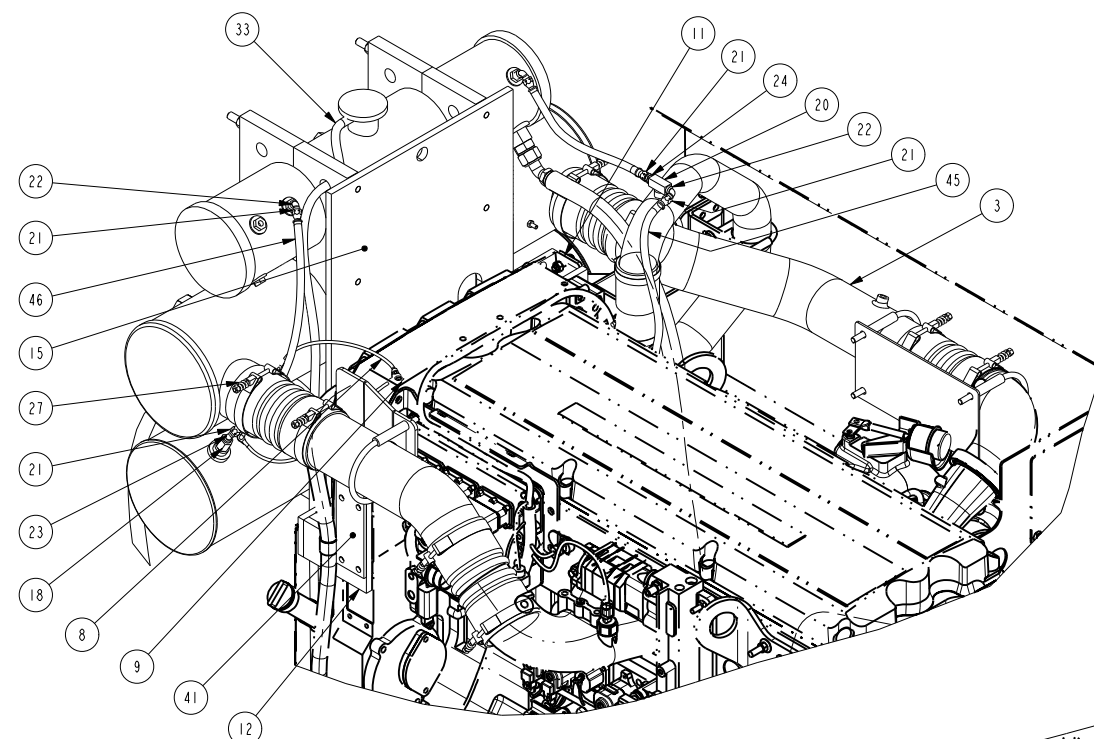

DETAIL A
SCALE 0.500

- NOTES:
- CAC HUMP HOSES QTY(4) & CLAMPS QTY(8) COME W/ ENGINE
 - ALL FITTINGS TO BE POSITIONED AS SHOWN
 - ALL PARTS TO BE CLEAN BEFORE ASSEMBLY
 - ALL OPENINGS ARE TO BE CAPPED OR PLUGGED AFTER ASSEMBLY
 - CHECK ALL FITTINGS FOR O-RING BEFORE MAKING CONNECTIONS
 - APPLY THREAD SEALANT ON ALL NPT THREADS

DIMENSIONS ARE IN: INCHES 1:1 ARE IN: INCHES	DO NOT SCALE PRINT	CM1 DATA CLASSIFICATION Cummins Confidential		Cummins Inc.	
DRAWING TOLERANCES APPLY TO PRIMARY DIMENSIONS UNLESS OTHERWISE SPECIFIED	SCALE 0.170	DWN: PBS		ITEM NAME ASSEMBLY, HEAT EXCHANGER LOW HP, CFP15E, SW	
H: ± 0.004 IN OR 0.10 mm K: ± 0.004 IN OR 0.10 mm L: ± 0.004 IN OR 0.10 mm M: ± 0.004 IN OR 0.10 mm N: ± 0.004 IN OR 0.10 mm P: ± 0.004 IN OR 0.10 mm Q: ± 0.004 IN OR 0.10 mm R: ± 0.004 IN OR 0.10 mm S: ± 0.004 IN OR 0.10 mm T: ± 0.004 IN OR 0.10 mm U: ± 0.004 IN OR 0.10 mm V: ± 0.004 IN OR 0.10 mm W: ± 0.004 IN OR 0.10 mm X: ± 0.004 IN OR 0.10 mm Y: ± 0.004 IN OR 0.10 mm Z: ± 0.004 IN OR 0.10 mm		DATE: 04NOV2014 FOR INTERPRETATION OF DIMENSIONING AND TOLERANCING, SEE ASME Y14.5-2009	MUST CONFORM TO CES 10903	CAD SHEET 1 OF 1	ITEM NUMBER A042D121
THIS DOCUMENT (AND THE INFORMATION SHOWN THEREIN) IS CONFIDENTIAL AND PROPRIETARY AND SHALL NOT BE DISCLOSED TO OTHERS IN HARD COPY OR ELECTRONIC FORM, REPRODUCED BY ANY MEANS, OR USED FOR ANY PURPOSE WITHOUT WRITTEN CONSENT OF CUMMINS INC.					REV 7

ITEM	QTY	DESCRIPTION	PART NUMBER
1	1	COOLER, JACKET WATER; CFP15E	10847
2	1	HEAT EXCHANGER, CAC; CFP15E	10848
3	1	TUBE, COOLANT, LOWER; CFP15E	10891
4	1	TUBE, COOLANT, UPPER; CFP15E FIREPUMP	10892
5	1	TUBE, CAC, IM SIDE; CFP15E FIREPUMP	10894
6	1	TUBE, CAC OUT; CFP15E-F50 thru F70	11718
7	1	HOSE, WATER FILL; CFP15E	12950
8	1	DRAIN VALVE, 1/4"NPT; DC604-4	80511
9	1	BRACKET, ASSEMBLY,HHP; CFP15E,CAC SUPPORT	A042F160
10	1	BRACKET, HEAT EXCHANGER ; CFP15E	A058V256
11	1	BRACKET,MOUNTING; HEAT EXCHANGER	A059H839
12	16	COOLANT, FC EG PM, 1 GALLON	CC2743
13	1	ADAPTER, MALE JIC 37 DEG X MALE SAE ORB; -12	12235-12-12
14	1	HOSE, HOSE CAC 4 TO 4.5; FLEX FAB P/N FLX7735	10459
15	1	TANK, SURGE; CFP15E, FIREPUMP	10865
16	1	DETAIL, BRKT, HX MOUNTING; CFP15E FIREPUMP	11487
17	4	BRACKET, HEAT EXCHANGER MOUNTING; BACK	11488
18	1	BRACKET, RADIATOR TUBE	11581
19	1	CONNECTOR,FEMALE; -6 ORB X -4 FNPT,STEEL	12171-6-4
20	1	CONNECTOR,FEMALE; M12 ORR X -4 FNPT,STEEL	12181-M12-4
21	1	TEE,MALE BRANCH PIPE; -4 NPT, BRASS	12533-4
22	6	COUPLING,PLAIN HOSE; -4 FLR X -4 BARB,STEEL	12543-4-4
23	3	ELBOW,MALE ADAPTER; 90D -4 FLR X -4 NPT,BRS	12550-4-4
24	1	ELBOW,MALE ADAPTER; 45D -4 FLR X -4 NPT,BRS	12551-4-4
25	2	CONNECTOR,MALE; -4 FLR X -4 NPT,BRASS	12553-4-4
26	8	ROD, 1/2-13 x 12; 1-1/2" THREADED ENDS	12791
27	5	CLAMP, SPRING LOADED T-BOLT; 4.03-4.33	12975-0425
28	2	CLAMP, SPRING LOADED T-BOLT; 4.28-4.58	12975-0450
29	1	CLAMP, SPRING LOADED T-BOLT; 4.53-4.83	12975-0475
30	1	CLAMP,HOSE; .56-1.06 WORM	14990-10
31	8	CLAMP,HOSE; 2.06 - 3.00 WORM	14990-40
32	8	WASHER,PLAIN; 0.50, B18.21.1 TYPE A, NRW	20010-050
33	8	NUT,HEX; 0.50-13	20100-050
34	1	HOSE, RUBBER, 2.50 90 DEGREE; GATES 21891	21891
35	1	HOSE,FUEL LINE,5/16ID; 72"L	27003
36	1	VALVE,CHECK	3970799
37	3	HOSE,HUMP	4330737
38	1	ELBOW, 90 DEG, JIC X METRIC PORT; PARKER OR EQUIV.	12275-12-M27
39	1	SIGHT GLASS, 1/2" NPT	3277K34
40	1	CLAMP, U-BOLT; NELSON	89543K
41	3	CLAMP, U-BOLT, GUILLOTINE; 4.00", PLATED	89548K
42	2	HOSE,PLAIN; 2.50 ID X 6.00 LG EPDM	A042F057
43	1	HOSE,SILICONE; 5/8IN IDx42.00IN LONG	A042F072
44	1	BRACKET,CAC, IM SIDE; CFP15E FIREPUMP	A042F177
45	1	HOSE, COOLANT,RUBBER; GATES,2.50 I.D. 90 DEGREE	21115
46	1	HOSE,PARKER; 1/4IN ID X 12.00IN LONG	R-801-4
47	1	HOSE,PARKER; 1/4IN ID X 18.00IN LONG	R-801-4
48	1	HOSE,PARKER; 3/8IN ID X 14.00IN LONG	R-801-6

REV	REL NO	REVISION	DWN	CKD	APVD	DATE
28	2019-608	ADDED 4330737 (3) & 12975-0425 (5); REMOVED 16825 & 26963-20; UPDATED NOTES	RE123	MS707	MS707	16DEC19
29	2020-048	ADDED 80511; UPDATED PER 10891; CHANGED A042F057 LENGTH FROM 36" TO 6"	RE123	MS707	MS707	22JAN20
30	2020-057	UPDATED PER 10848,10865.HOSE LENGTH & NOTES:ADDED 3970799,14990-10 & A042F072	NO134	MS707	MS707	14MAY20

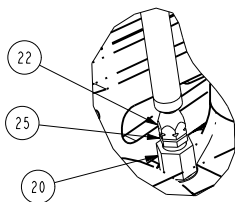
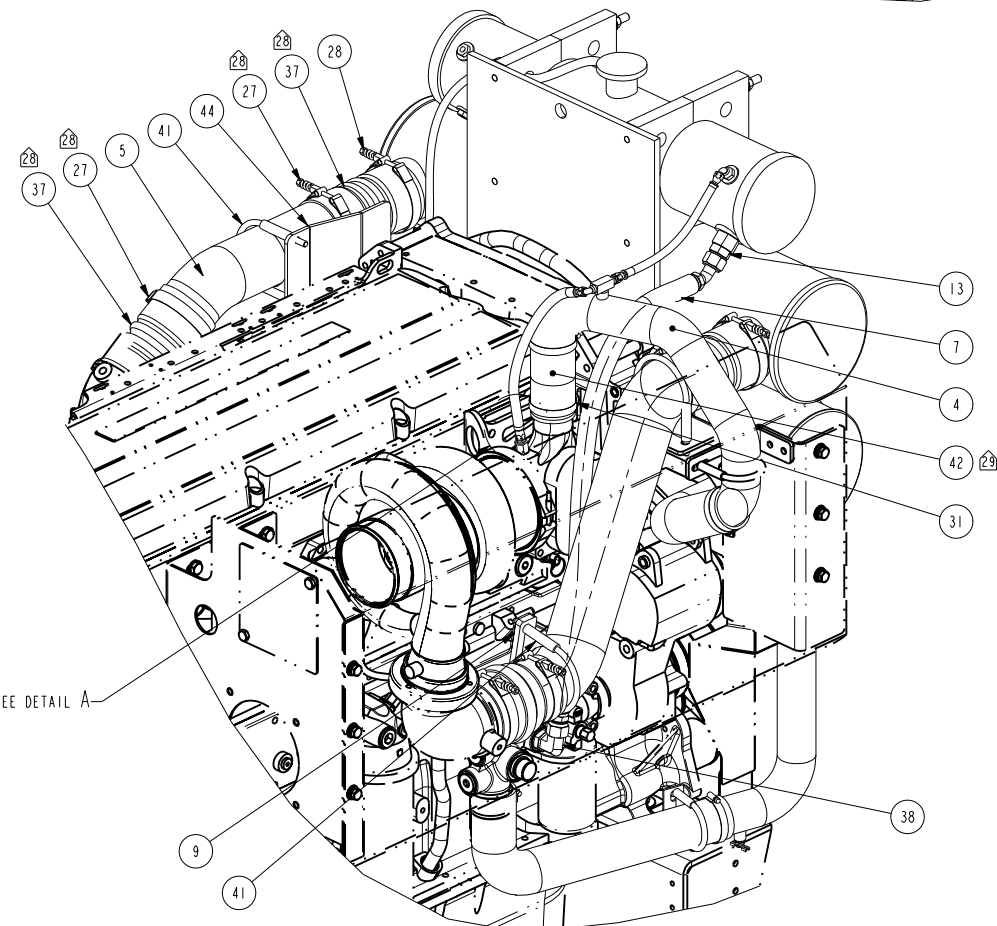
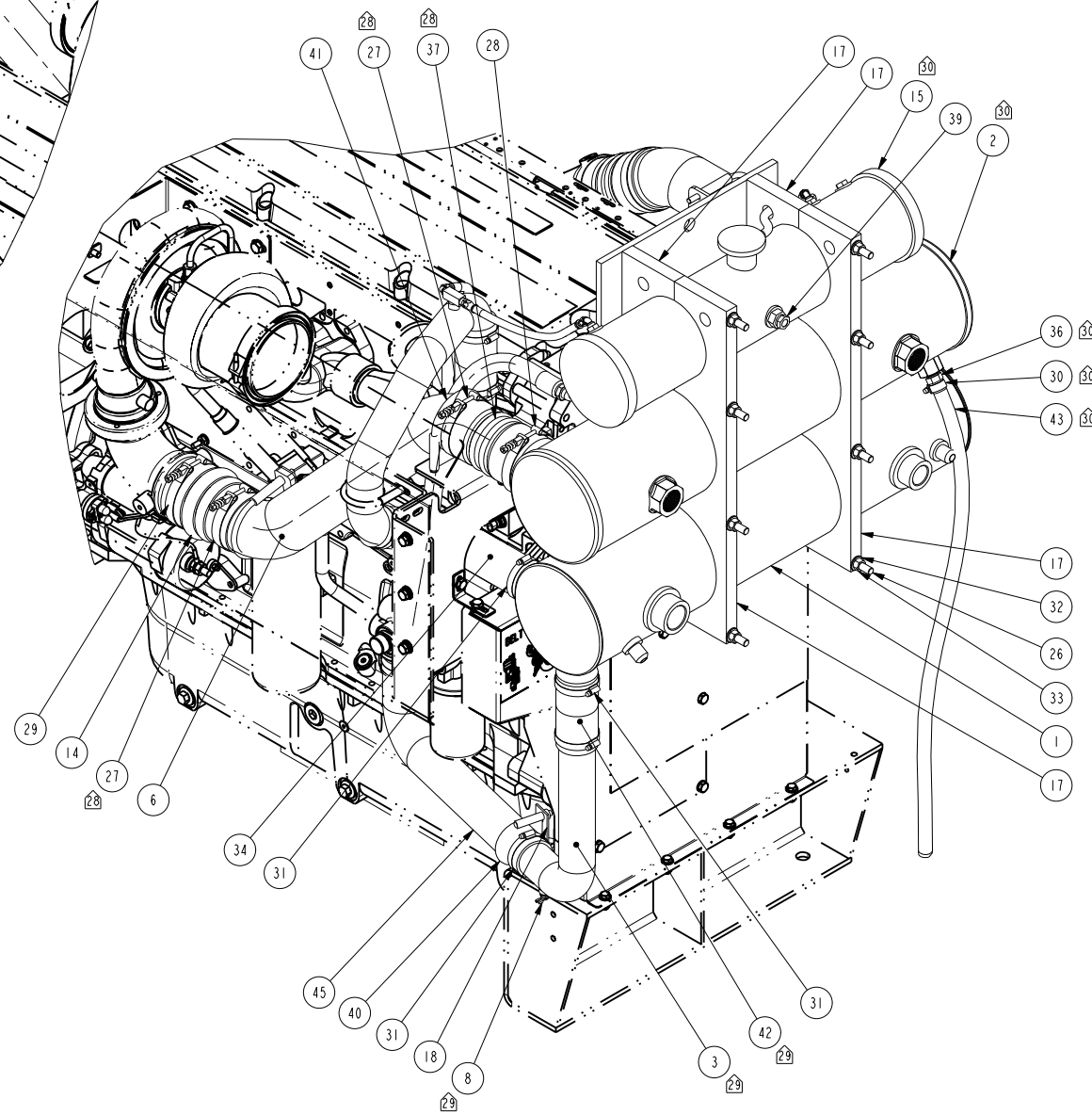
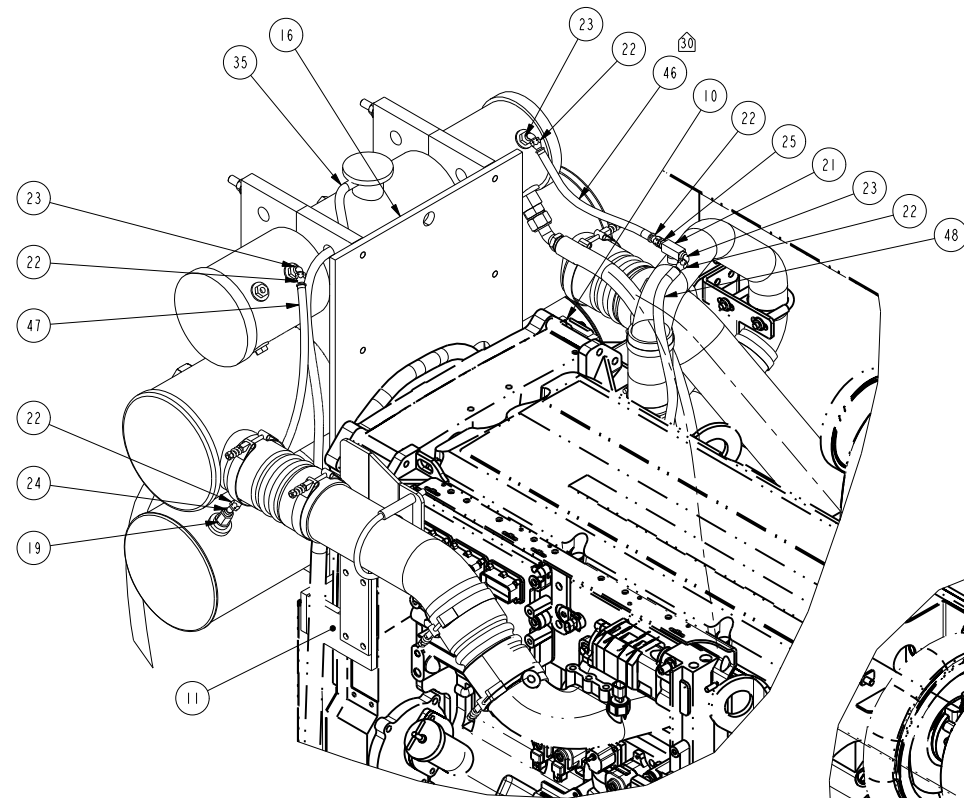

DETAIL A
SCALE 0.500

SEE DETAIL A

- NOTES:
1. ALL FITTINGS TO BE POSITIONED AS SHOWN
 2. ALL PARTS TO BE CLEAN BEFORE ASSEMBLY
 3. ALL OPENINGS ARE TO BE CAPPED OR PLUGGED AFTER ASSEMBLY
 4. CHECK ALL FITTINGS FOR O-RING BEFORE MAKING CONNECTIONS
 5. APPLY THREAD SEALANT ON ALL NPT THREADS

DIMENSIONS ARE IN: INCHES 1:1 ARE IN: INCHES DRAWING TOLERANCES APPLY TO PRIMARY DIMENSIONS UNLESS OTHERWISE SPECIFIED F: ± .010 IN OR 0.25 mm M: ± .005 IN OR 0.125 mm H: ± .002 IN OR 0.05 mm ANGULAR TOLERANCE: ±	DO NOT SCALE PRINT SCALE 0.175	CMI DATA CLASSIFICATION Cummins Confidential DWN: S.DANFORTH CKD: APVD: DATE: 25 JUN 2007	Cummins Inc. ITEM NAME ASSEMBLY, HEAT EXCHANGER HIGH HP, CFP15E CAD SHEET 1 OF 1 ITEM NUMBER 11492-02 REV 30
--	-----------------------------------	--	--

BILL OF MATERIAL			
ITEM	QTY	DESCRIPTION	PART NUMBER
1	1	ELEMENT, FILTER, CFPI5E; SPECIAL	10857
2	1	SHROUD, INTAKE; CFPI5E	11715
3	2	CLAMP, T-BOLT; 6.28-6.59	13164-0650
4	1	HUMP HOSE; 5.50" X 6.00"	3316612S
5	1	SERVICE INDICATOR, FILTER; DONALDSON D-RAX00-2352	D-RAX00-2352

REV	REL NO	REVISION	DWN	CKD	APVD	DATE
D	2013-699	ADDED 11715, 3316612S & 13164-0650; REMOVED AC600 & 89839K	PBS			28OCT13
6	2020-026	REMOVED 13164-0650 (1); REPLACED RAX00-2352 WITH D-RAX00-2352	RE123	MS707	MS707	27JAN20

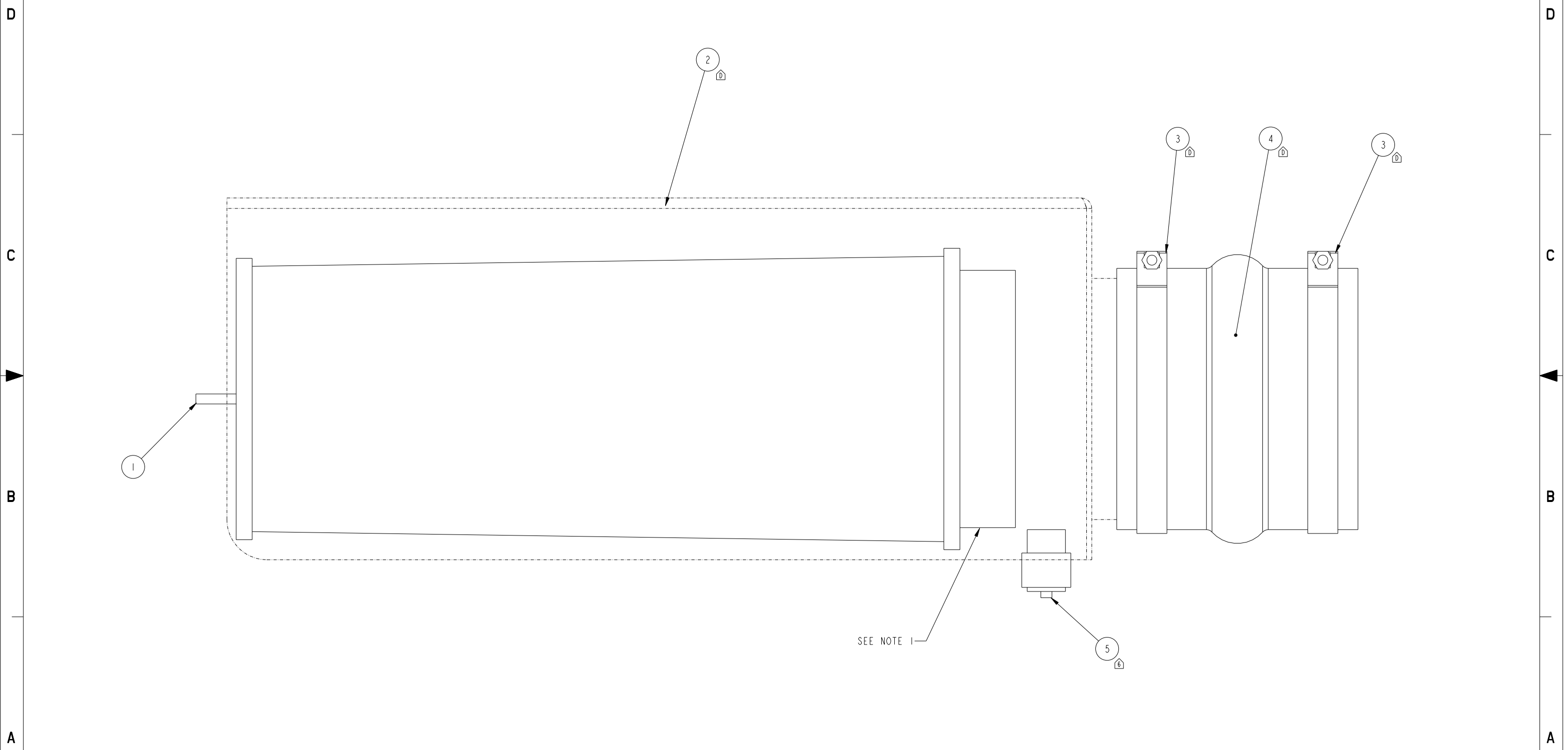

NOTE:
1. (1) CLAMP COMES WITH AIR CLEANER

DIMENSIONS ARE IN: INCHES [] ARE IN: - DRAWING TOLERANCES APPLY TO PRIMARY DIMENSIONS UNLESS OTHERWISE SPECIFIED X.1: ± .1 IN OR 4 mm X.2: ± .1 IN OR 3.7 mm X.3: ± .030 IN OR 0.75 mm X.4: ± .010 IN OR 0.25 mm ANGULAR TOLERANCE: ±	DO NOT SCALE PRINT SCALE .875 	CMI DATA CLASSIFICATION Cummins Confidential DWN S. DANFORTH CKD - APVD - DATE APROG		Cummins Inc. ITEM NAME ASSEMBLY, AIR CLEANER CFPI5E	
				THIS DOCUMENT AND THE INFORMATION SHOWN THEREON IS CONFIDENTIAL AND PROPRIETARY AND SHALL NOT BE DISCLOSED TO OTHERS IN HARD COPY OR ELECTRONIC FORM, REPRODUCED BY ANY MEANS, OR USED FOR ANY PURPOSE WITHOUT WRITTEN CONSENT OF CUMMINS INC.	FOR INTERPRETATION OF DIMENSIONING AND TOLERANCING, SEE ASME Y14.5-2009

BILL OF MATERIAL			
ITEM	QTY	DESCRIPTION	PART NUMBER
1	1	ELEMENT, FILTER, CFP15E; SPECIAL	10857
2	1	SHROUD, INTAKE; CFP15E	11715
3	1	CLAMP, T-BOLT; 5.78-6.09	13164-0600
4	1	CLAMP, T-BOLT; 6.28-6.59	13164-0650
5	1	HUMP HOSE, 5.50" X 6.00"	3316622-S
6	1	SERVICE INDICATOR, FILTER; DONALDSON D-RAX00-2352	D-RAX00-2352

REV	REL NO	REVISION	DWN	CKD	APVD	DATE
D	2013-669	ADDED 11715, 13164-0650, 13164-0600 & 3316622-S; REMOVED AC600 & 89849K	PBS			28OCT13
6	2020-026	REMOVED 13164-0650 (1); REPLACED RAX00-2352 WITH D-RAX00-2352	RE123	MS707	MS707	27JAN20

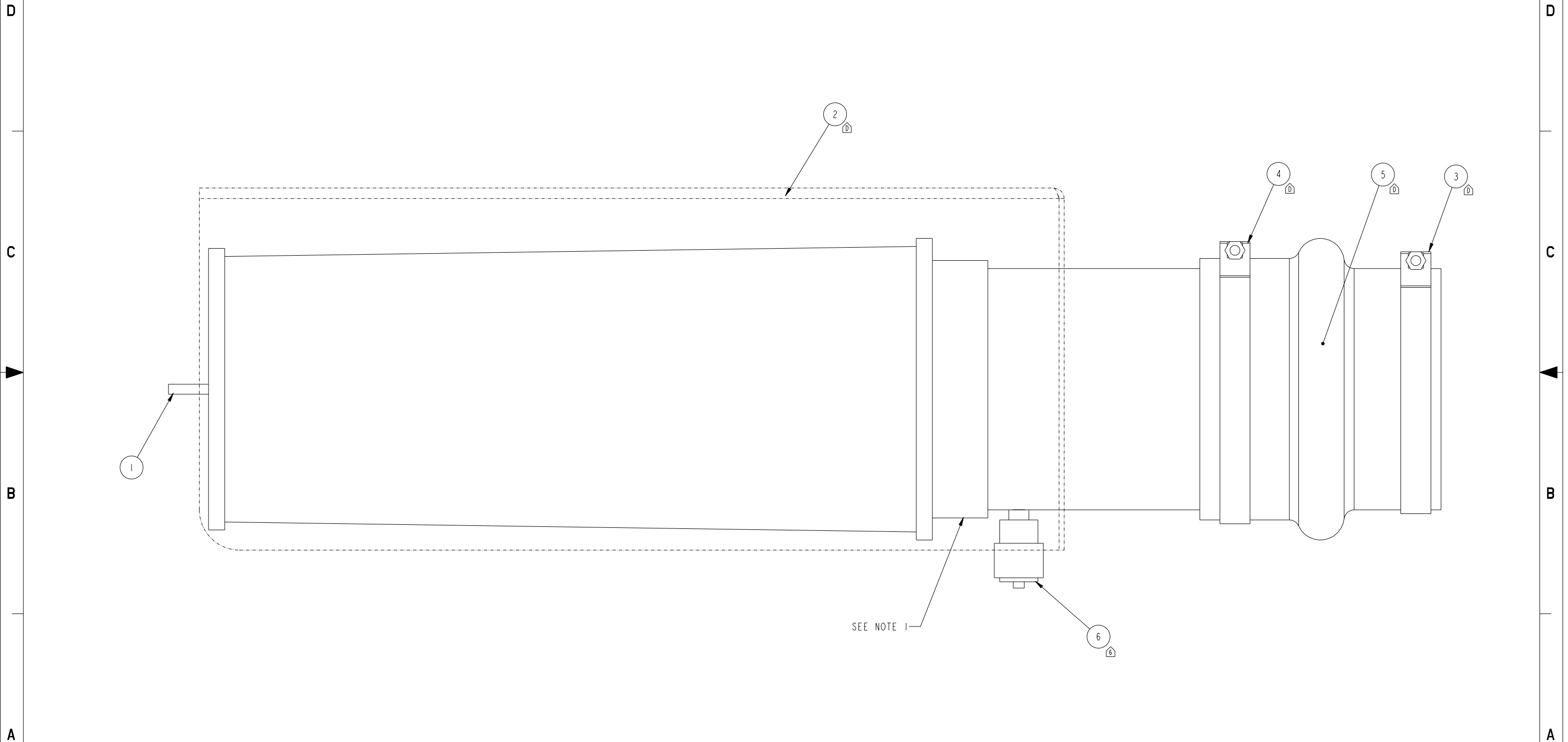

NOTE:
1. (1) CLAMP COMES WITH AIR CLEANER

DIMENSIONS ARE IN: INCHES 1. ARE IN: -	DO NOT SCALE PRINT SCALE .875	CWI DATA CLASSIFICATION Cummins Confidential		Cummins Inc.	
DRAWING TOLERANCES APPLY TO PRIMARY DIMENSIONS UNLESS OTHERWISE SPECIFIED X.1: ±.1 IN OR 3 mm X.2: ±.01 IN OR 0.25 mm X.3: ±.001 IN OR 0.025 mm ANGULAR TOLERANCES: ±	FOR INTERPRETATION OF DIMENSIONING AND TOLERANCING, SEE ASME Y14.5-2009	DWN S. DANFORTH CKD - APVD - DATE APROG		ITEM NAME ASSEMBLY, AIR CLEANER CFP15E	CAD SHEET 1 OF 1
<small>THIS DOCUMENT AND THE INFORMATION SHOWN THEREON IS CONFIDENTIAL AND PROPRIETARY AND SHALL NOT BE DISCLOSED TO OTHERS IN HARD COPY OR ELECTRONIC FORM, REPRODUCED BY ANY MEANS, OR USED FOR ANY PURPOSE WITHOUT WRITTEN CONSENT OF CUMMINS INC.</small>			<small>MUST CONFORM TO CES 10903</small>		

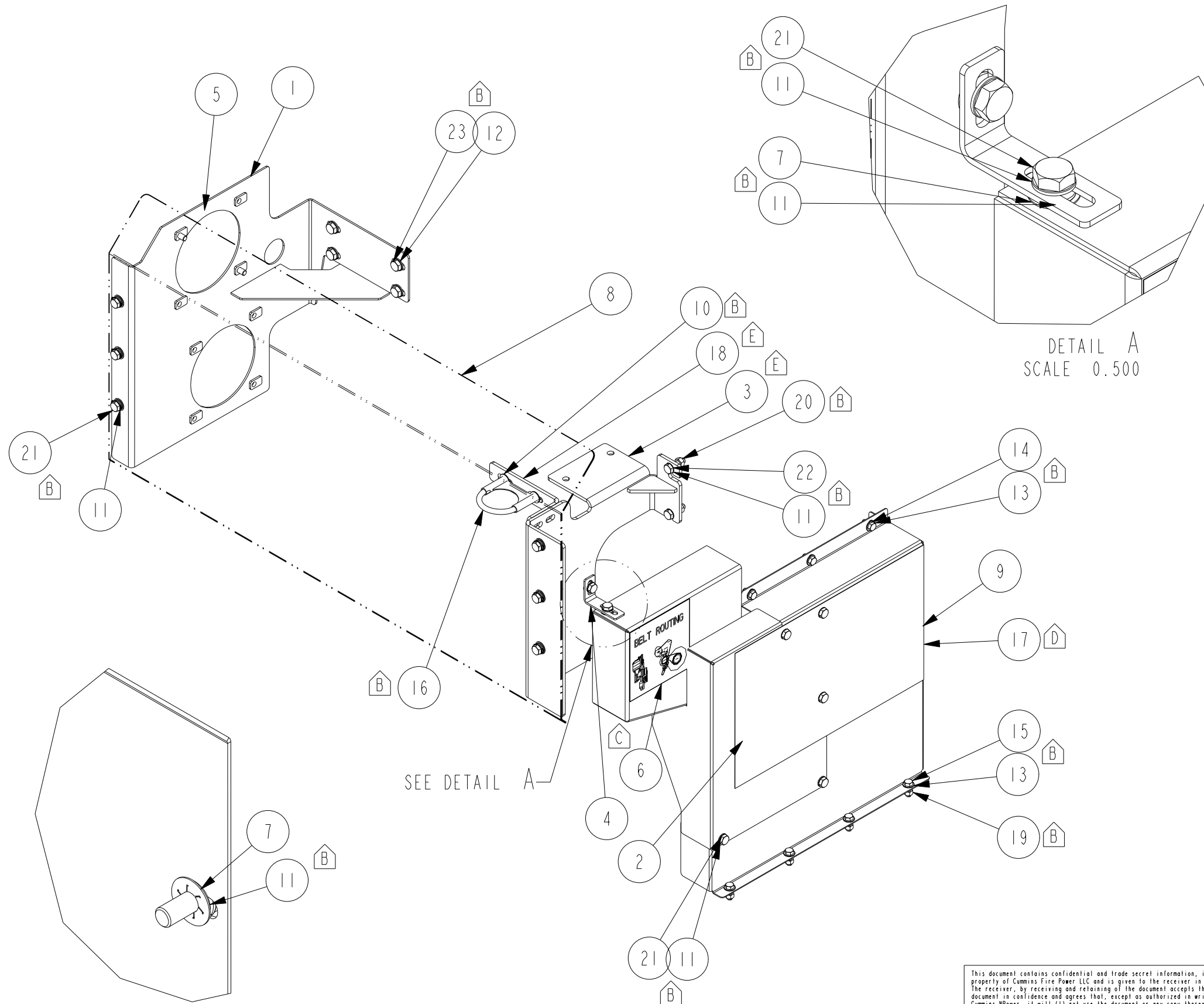

BILL OF MATERIAL			
ITEM	QTY	DESCRIPTION	PART NUMBER
1	1	BRACKET, HEAT SHIELD, REAR, CFPI5E	16710
2	1	GUARD, PULLEY, CFPI5E	16717
3	1	BRACKET, HEAT SHIELD, FRONT, CFPI5E	A042H314
4	1	BRACKET, MOUNTING, GUARD, FIREPUMP	8593
5	1	PLATE, BLOCK OFF, CFPI5E-F30	11717
6	1	DECAL, BELT ROUTING, CFPI5E	11816
7	15	WASHER, RETAINING, M10	16662-13
8	1	HEAT SHIELD, CFPI5E	16711
9	1	COVER, PULLEY, CFPI5E	16712
10	2	WASHER, FLAT, 0.31	20020
11	28	WASHER, FLAT, M10	20020-M10
12	4	WASHER, FLAT, M12	20020-M12
13	7	WASHER, FLAT, SMALL, 0.38	20020
14	3	SCREW, HH, 0.38-16x0.75	20238-075
15	4	SCREW, HH, 0.38-16x1.00	20238-100
16	1	CLAMP, U-BOLT, 2.50"	89543K
17	1	DECAL, VALVE POSITION, CFPI5E	A042D485
18	1	BRACKET, TUBE	A042H317
19	4	NUT, HEX, PT, .38-16	20130-038
20	2	NUT, HEX, PT, M10-1.50	20140-M10
21	15	SCREW, HH, M10-1.50x25	20310-025
22	2	SCREW, HH, M10-1.50x35	20310-035
23	4	SCREW, HH, M12-1.75x25	20312-025

TYPICAL GUARDING FASTENERS
SCALE 0.500

REV	ECO	DESCRIPTION OF REVISION	REV BY	DATE
E	2016-543	DELETE: 16709. ADD: A042H314 AND A042H317	PBS	30DEC2014
D	2014-874	A042D485 WAS 11818	PBS	30DEC2014
C	2013-669	DELETED: 11715. 20310-025 WAS QTY 19 ADDED: 11816 AND 11818	PBS	28OCT2013
B	2011-058	UPDATED FASTENERS AND COMPONENT	S DUBICK	19-MAY-11

This document contains confidential and trade secret information, is the property of Cummins Fire Power LLC and is given to the receiver in confidence. The receiver, by receiving and retaining of the document accepts the document in confidence and agrees that, except as authorized in writing by Cummins NPower, it will (1) not use the document or any copy thereof or the confidential or trade secret information therein, (2) not copy the document, (3) not disclose to others either the document or the confidential or trade secret information therein, and (4) upon completion of the need to retain the document, or upon demand, return the document, all copies thereof, and all material copied therefrom. COPYRIGHT Cummins Fire Power LLC

	CUMMINS FIRE POWER LLC CORPORATE OFFICE 1600 BUERKLE ROAD WHITE BEAR LAKE, MN WWW.CUMMINSFIREPOWER.COM	CUSTOM DESIGN AND UPFIT CENTER 875 LAWRENCE DRIVE DEPERE, WISCONSIN
	ASSEMBLY, GUARDING CFPI5E	

UNLESS OTHERWISE SPECIFIED ALL DIMENSION TOLERANCES ARE			
ANGULAR DIMENSIONS ± 1°	MACHINED SURFACES	IMPERIAL UNITS	METRIC UNITS
THIRD ANGLE PROJECTION	125	MACHINE TOLERANCES .XX ± 0.010 .XXX ± 0.005	MACHINE TOLERANCES .X ± 0.4 .XX ± 0.2
		FORM TOLERANCES .XX ± 0.030 .XXX ± 0.015	FORM TOLERANCES .X ± 0.8 .XX ± 0.4
		FAB TOLERANCES .XX ± 0.060 .XXX ± 0.030	FAB TOLERANCES .X ± 1.5 .XX ± 0.8
DWG UNITS: IN/LB/S	DRAWN BY: DAN PRO-ENGINEER	SCALE: 0.125	DATE: 22-FEB-10 INIT ECO: -
EST WEIGHT: 0.000	SHEET 1 OF 1	DRAWING NO: 16707	

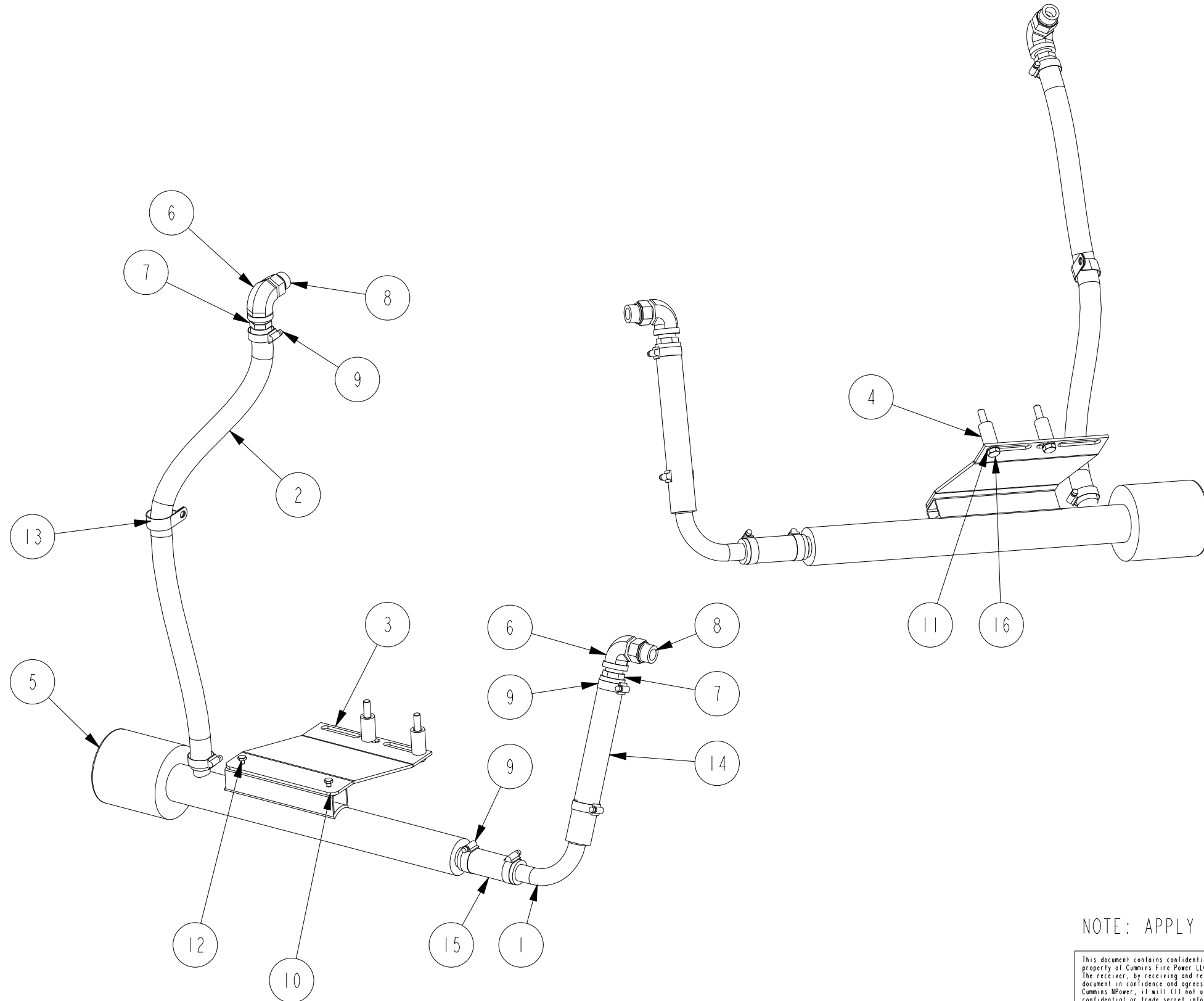

BILL OF MATERIAL			
ITEM	QTY	DESCRIPTION	PART NUMBER
1	1	TUBE, LOWER, COOLANT HEATER, QSX15-C	18153
2	1	HOSE, 1.00IN IDX36IN, SILICONE	A042F061
3	1	BRACKET, COOLANT HEATER, MULTI-UNIT	8143
4	2	SPACER, MOUNTING, SECONDARY ECM	9508
5	1	HEATER, COOLANT, 3KW, ADJ. VOLT, WATLOW 3-10-42-5PA	11577
6	2	ELB, 90 DEG, -8 NPT X -12 FMNPT	12195-8-12
7	2	FTG, STR, -16 BEAD X -12 NPT	12545-16-12
8	2	FTG, STR, -8 FNPT X M27 ORB	14739-8-M27
9	6	CLAMP, WORM, .81 - 1.50	14990-16
10	2	WASHER, FLAT, 0.25	20020
11	2	WASHER, FLAT, M10	20020-M10
12	2	SCREW, HH, 0.25-20x1.00	20225-100
13	1	CLAMP, LOOM, 1.50 ID	26963-24
14	1	HOSE, 1.00 IN IDx36IN SILICONE, CUT TO 10.00 INCHES LONG	A042F061
15	1	HOSE, 1.00 IN IDx36IN SILICONE, CUT TO 4.00 INCHES LONG	A042F061
16	2	SCREW, HH, M10-1.50x70	20310-070

NOTE: APPLY THREAD SEALANT ON ALL NPT THREADS.

This document contains confidential and trade secret information, is the property of Cummins Fire Power LLC and is given to the receiver in confidence. The receiver, by receiving and retaining of the document accepts the document in confidence and agrees that, except as authorized in writing by Cummins NPower, it will (1) not use the document or any copy thereof or the confidential or trade secret information therein, (2) not copy the document, (3) not disclose to others either the document or the confidential or trade secret information therein, and (4) upon completion of the need to retain the document, or upon demand, return the document, all copies thereof, and all material copied therefrom. COPYRIGHT Cummins Fire Power LLC



CUMMINS FIRE POWER LLC
CORPORATE OFFICE
1600 BUERKLE ROAD
WHITE BEAR LAKE, MN
WWW.CUMMINSFIREPOWER.COM

CUSTOM DESIGN
AND UPFIT CENTER
875 LAWRENCE DRIVE
DEPERE, WISCONSIN

ASSEMBLY, COOLANT HEATER
CFPI5E

UNLESS OTHERWISE SPECIFIED ALL DIMENSION TOLERANCES ARE

ANGULAR DIMENSIONS ± 1°	MACHINED SURFACES	IMPERIAL UNITS	METRIC UNITS
THIRD ANGLE PROJECTION	125	MACHINE TOLERANCES .XX ± 0.010 .XXX ± 0.005	MACHINE TOLERANCES .X ± 0.4 .XX ± 0.2
		FORM TOLERANCES .XX ± 0.010 .XXX ± 0.015	FORM TOLERANCES .X ± 0.8 .XX ± 0.4
		FAB TOLERANCES .XX ± 0.030 .XXX ± 0.030	FAB TOLERANCES .X ± 1.5 .XX ± 0.8

DWG UNITS: IN/LB/S	DRAWN BY: PBS PRO-ENGINEER	DATE: 16NOV2016 INIT ECO: 2016-668
SCALE: 0.143	SHEET 1 OF 1	DRAWING NO: A042J191
EST WEIGHT: 37.721		

REV	ECO	DESCRIPTION OF REVISION	REV BY	DATE

BILL OF MATERIAL			
ITEM	QTY	DESCRIPTION	PART NUMBER
1	1	HARNES, WIRE, ECM A/B, CFP15E, FPDP GEN 2	A042H298
2	1	HARNES, WIRE, POWER & INTERFACE, CFP15E, FPDP GEN 2	A042H299
3	1	HARNES, WIRE, SENSOR & ACTUATOR, CFP15E, FPDP GEN 2	A042J134
4	1	SENSOR, MAG PICK UP, #5MT2005	9569
5	1	KIT, LOOSE WIRES, QSX15	24947
6	2	SENSOR, PRESSURE	4921499

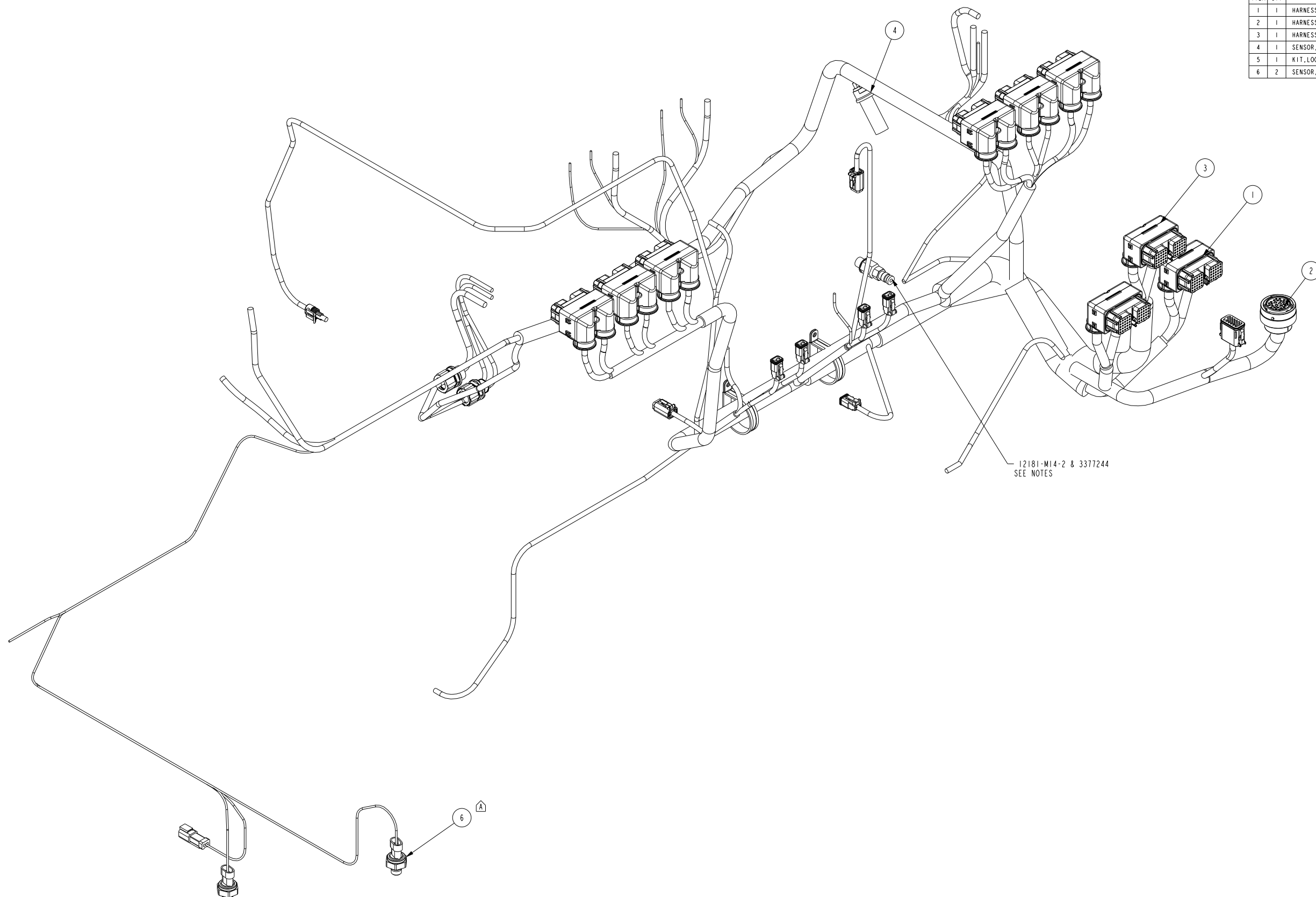

NOTE:
 1. APPLY THREAD SEALANT ON ALL NPT THREADS.
 2. DYNAMOMETER TESTING ONLY: REMOVE PLUG FROM OIL GALLEY ON LEFT SIDE OF ENGINE AND KEEP FOR FUTURE USE. INSTALL 12181-M14-2 & 3377244 TO DYNAMOMETER TEST. WHEN FINISHED, REMOVE FITTINGS AND REPLACE WITH REMOVED PLUG. STORE 12181-M14-2 & 3377244 FITTINGS FOR FUTURE USE IN TEST CELL AREA.

<small>This document contains confidential and trade secret information, is the property of Cummins Power LLC and is loaned to the customer in confidence. The customer, by reviewing and accepting of this document, agrees to maintain the confidentiality of trade secret information therein. It is not to be used, copied, reproduced, or otherwise disclosed in any way without the express written consent of Cummins Power LLC. All rights reserved. © 2017 Cummins Power LLC. All other rights reserved.</small>		CUMMINS CONFIDENTIAL 		<small>CUMMINS NPOWER LLC CORPORATE OFFICE 1600 BIERLIE ROAD WHITE BEAR LAKE, MN WWW.CUMMINSPOWER.COM</small>		<small>CUSTOM DESIGN AND SUPPORT CENTER 875 LAWRENCE DRIVE DEPERE, WISCONSIN</small>	
ASSEMBLY, SENSORS & HARNESSING CFP15E				DRAWN BY: RMB DATE: 25JAN2017		INIT ECO: 2017-043	
UNLESS OTHERWISE SPECIFIED ALL DIMENSION TOLERANCES ARE:		SURFACES:		DWG UNITS: IN/LB/S		SHEET 1 OF 2	
ANGULAR DIMENSIONS ± P		FINISH:		SCALE: 0.375		EST WEIGHT: 0.002	
125°		PRO-ENGINEER		DATE: 09MAR2017		DRAWING NO: A042H297	
A 2017-137 ADD 4921499		REV ECO		DESCRIPTION OF REVISION		REV BY DATE	

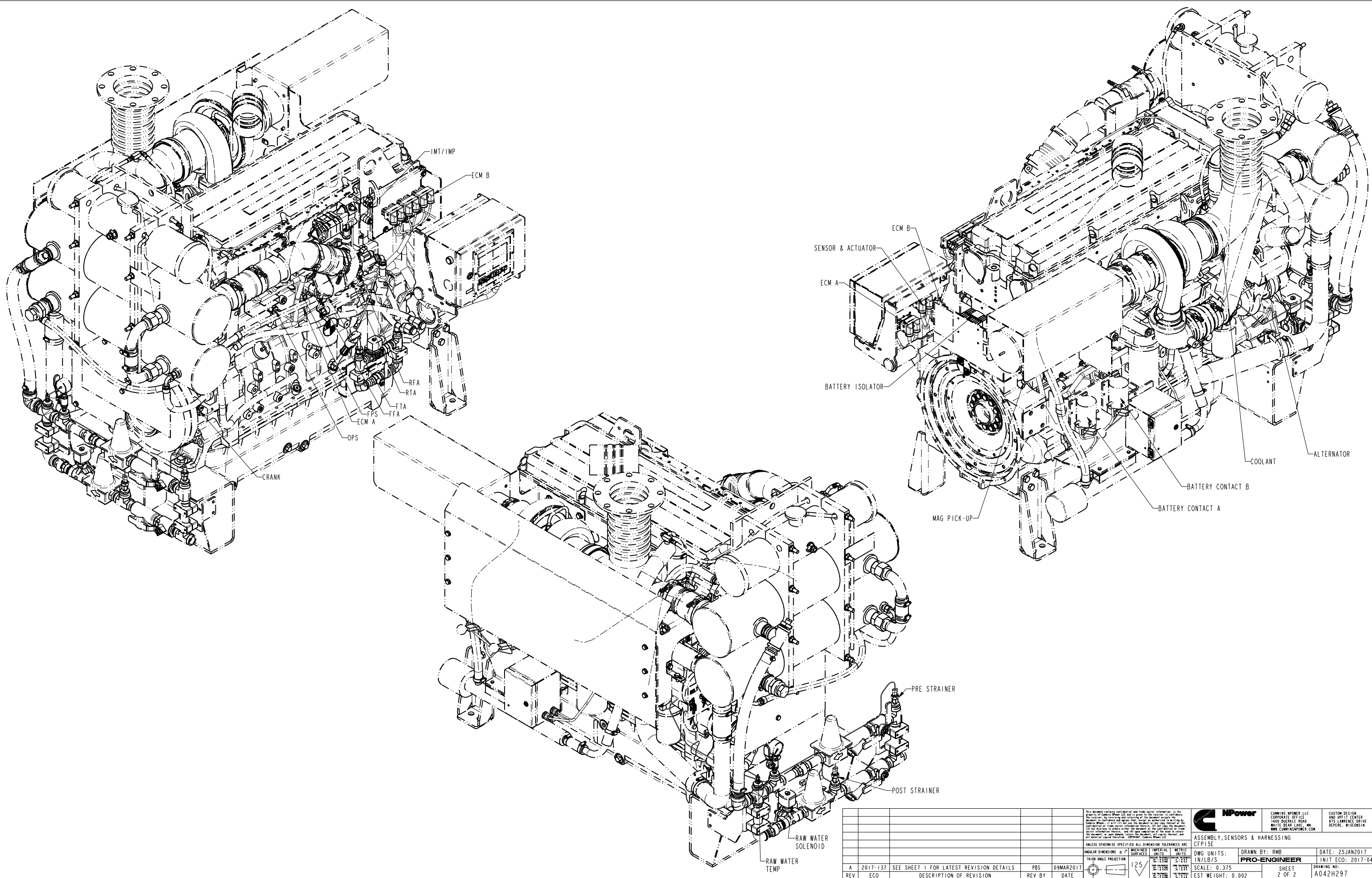

<small>This document contains confidential and trade secret information, is the property of Cummins Power LLC and is loaned to the customer on condition that the customer will maintain and protect this information as confidential. The customer, by reviewing and accepting this document, agrees to the confidentiality of trade secret information therein. If not clear, the customer will not disclose, in any way, the contents of this document or trade secret information contained herein, and will not use, copy, or otherwise disseminate the contents of this document, or any information, without the express written consent of Cummins Power LLC. If you have any questions, please contact your account manager or visit our website at www.cummins.com.</small>				<small>CUMMINS NPOWER LLC CORPORATE OFFICE 1600 BERKLEY ROAD WHITE BEAR LAKE, MN WWW.CUMMINSPOWER.COM</small>		<small>CUSTOM DESIGN AND OPTIC CENTER 875 LAWRENCE DRIVE DEPERE, WISCONSIN</small>	
<small>UNLESS OTHERWISE SPECIFIED ALL DIMENSION TOLERANCES ARE</small>							
<small>ANGULAR DIMENSIONS ± 1°</small>				<small>MACHINED SURFACES</small>		<small>IMPERIAL METRIC</small>	
<small>FINISH</small>				<small>IN/LB/S</small>		<small>MM/KG</small>	
<small>THIRD ANGLE PROJECTION</small>				<small>125</small>		<small>SCALE: 0.375</small>	
<small>EST WEIGHT: 0.002</small>		<small>SHEET 2 OF 2</small>		<small>DRAWING NO: A042H297</small>		<small>DATE: 25JAN2017</small>	
<small>ASSEMBLY, SENSORS & HARNESSING</small>		<small>CFPISE</small>		<small>DRAWN BY: RMB</small>		<small>INIT ECO: 2017-043</small>	
<small>PRO-ENGINEER</small>		<small>REV A</small>		<small>ECO</small>		<small>DESCRIPTION OF REVISION</small>	
<small>REV</small>		<small>2017-137</small>		<small>09MAR2017</small>		<small>DATE</small>	
<small>ECO</small>		<small>DESCRIPTION OF REVISION</small>		<small>REV BY</small>		<small>DATE</small>	

BILL OF MATERIAL			
ITEM	QTY	DESCRIPTION	PART NUMBER
1	1	BRACKET, ECM MOUNTING, CFP15E	A042J764
2	1	ECM, CM570	4309175RX
3	6	SCREW, HH, M8-1.25x40	20308-040

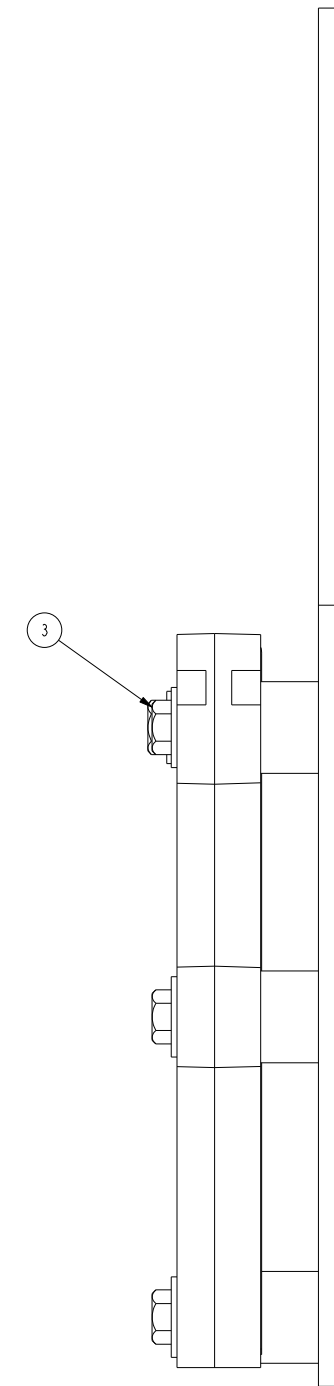
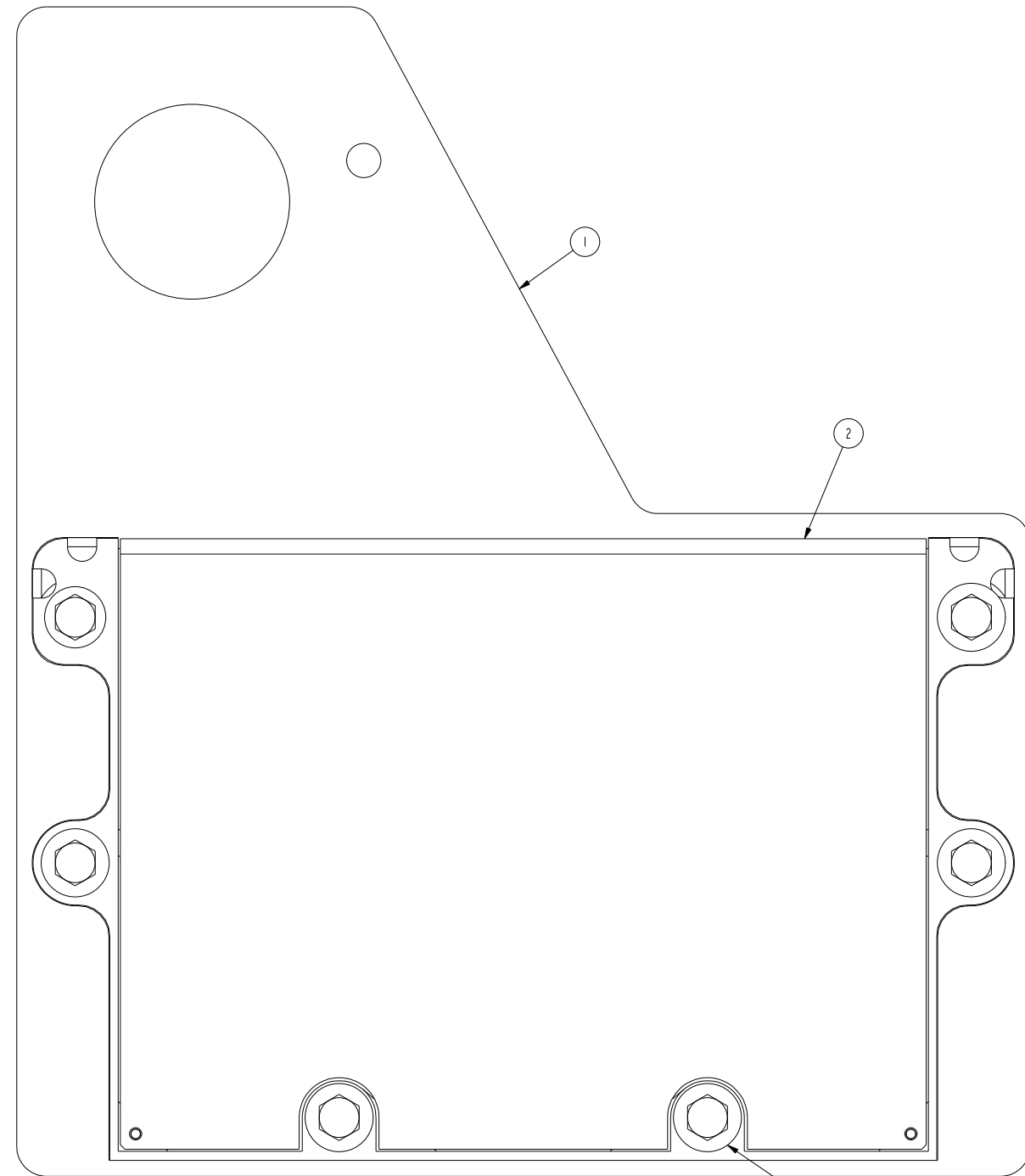

INSTALL GROMMETS SUPPLIED WITH ECM

<small>This document contains confidential and trade secret information, is the property of Cummins Fire Power LLC and is loaned to the recipient for use only for the purposes stated herein. It is not to be distributed, copied, or otherwise used without the express written consent of Cummins Fire Power LLC. If you are not an intended recipient, you should not disseminate, distribute or take any action in reliance on the information herein. If you have received this document in error, please notify the sender immediately by e-mail at firepower@cumminsfirepower.com or by phone at 1-800-368-7263. Thank you for your cooperation.</small>				CUMMINS FIRE POWER LLC CORPORATE OFFICE 1600 BUECKLE ROAD WHITE BEAR LAKE, WI WWW.CUMMINSFIREPOWER.COM		CUSTOM DESIGN AND UPFIT CENTER 875 LAWRENCE DRIVE DEPERE, WISCONSIN	
UNLESS OTHERWISE SPECIFIED ALL DIMENSION TOLERANCES ARE:				ASSEMBLY, SECONDARY ECM			
FINISH: ANGLE PROJECTION		MACHINED SURFACES:		DWG UNITS:		DRAWN BY:	
± 0.005		± 0.005		IN/LB/S		PBS	
DATE: 24MAY2017		DATE: 19JAN2017		SCALE: 1.000		SHEET 1 OF 1	
ECO		DESCRIPTION OF REVISION		EST WEIGHT: 0.000		DRAWING NO: A042J761	

REV	DATE	BY	DESCRIPTION
A	2017-335	PBS	ADDED NOTE
REV	ECO		DESCRIPTION OF REVISION

BILL OF MATERIAL

ITEM	QTY	DESCRIPTION	PART NUMBER
1	1	MOUNT, OPERATOR STATION, CFP CONTROL PANEL	22318
2	2	ISOLATOR, PLATE MOUNT, 3 LB (YELLOW MARK)	15400
3	2	ISOLATOR, PLATE MOUNT, 6 LB (RED MARK)	15412
4	12	RIVET, ALUMINUM, STEEL SHANK, 0.156 DIA, 0.25-0.38 GRIP	15414
5	2	FENDER WASHER, 0.281 X 1.25	15421
6	4	SCREW, SELF LOCKING, 0.25-20 X 1.00, PH OR BH	15422

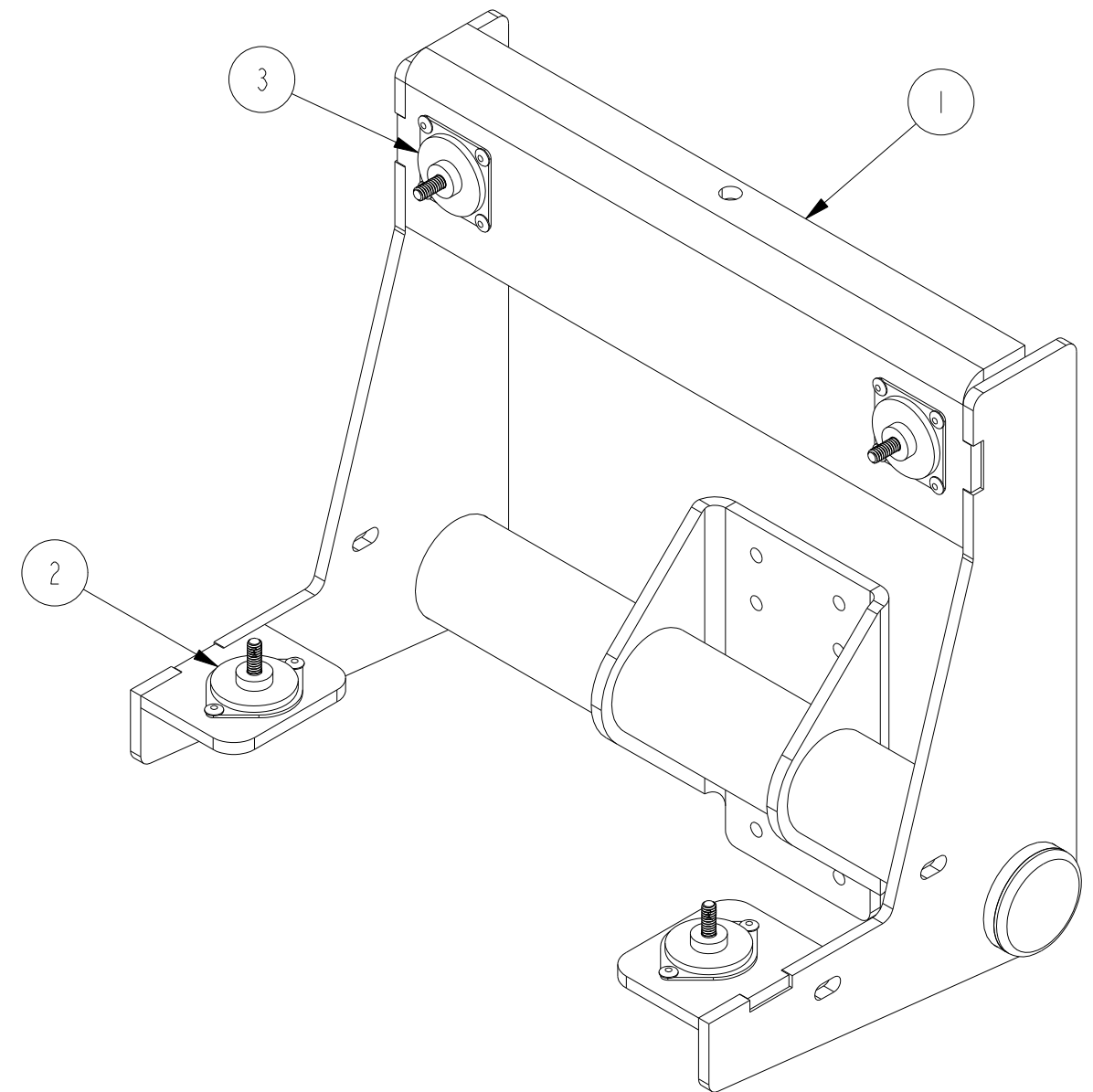
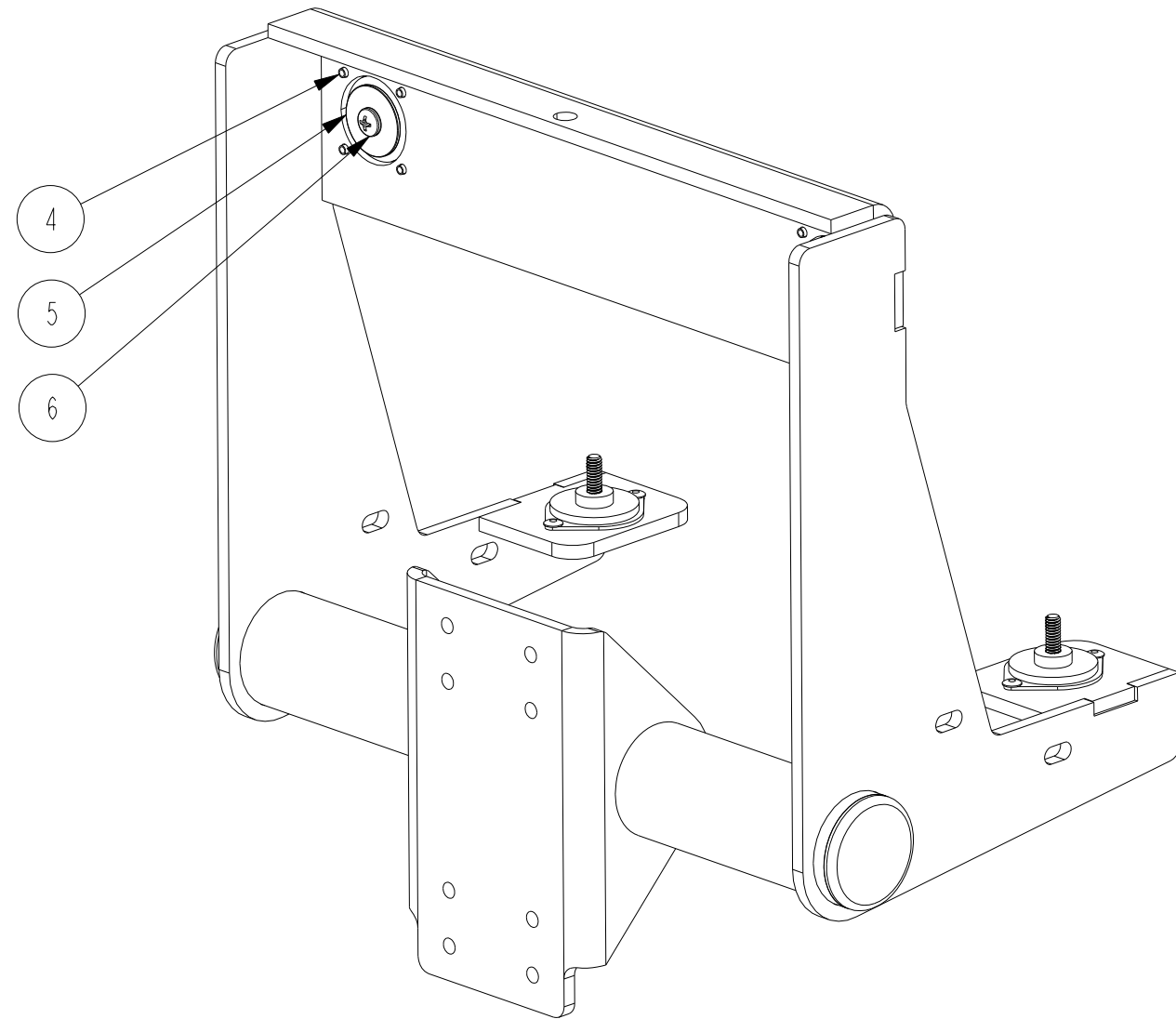

This document contains confidential and trade secret information, is the property of Cummins Fire Power LLC and is given to the receiver in confidence. The receiver, by receiving and retaining of the document accepts the document in confidence and agrees that, except as authorized in writing by Cummins NPower, it will (1) not use the document or any copy thereof or the confidential or trade secret information therein, (2) not copy the document, (3) not disclose to others either the document or the confidential or trade secret information therein, and (4) upon completion of the need to retain the document, or upon demand, return the document, all copies thereof, and all material copied therefrom. COPYRIGHT Cummins Fire Power LLC



CUMMINS FIRE POWER LLC
CORPORATE OFFICE
1600 BUERKLE ROAD
WHITE BEAR LAKE, MN
WWW.CUMMINSFIREPOWER.COM

CUSTOM DESIGN
AND UPFIT CENTER
875 LAWRENCE DRIVE
DEPERE, WISCONSIN

UNLESS OTHERWISE SPECIFIED ALL DIMENSION TOLERANCES ARE

ANGULAR DIMENSIONS ± 1°	MACHINED SURFACES	IMPERIAL UNITS	METRIC UNITS
THIRD ANGLE PROJECTION	125	MACHINE TOLERANCES .XX ± 0.010 .XXX ± 0.005	MACHINE TOLERANCES .X ± 0.4 .XX ± 0.2
		FORM TOLERANCES .XX ± 0.030 .XXX ± 0.015	FORM TOLERANCES .X ± 0.8 .XX ± 0.4
		FAB TOLERANCES .XX ± 0.060 .XXX ± 0.030	FAB TOLERANCES .X ± 1.5 .XX ± 0.8

ASSEMBLY, CONTROL PANEL MOUNTING
CFP POWER UNITS

DWG UNITS: IN/LB/S	DRAWN BY: S DUBICK PRO-ENGINEER	DATE: 26-SEP-12 INIT ECO: 2012-392
SCALE: 0.333	SHEET 1 OF 1	DRAWING NO: 21249
EST WEIGHT: 16.439		

REV	ECO	DESCRIPTION OF REVISION	REV BY	DATE

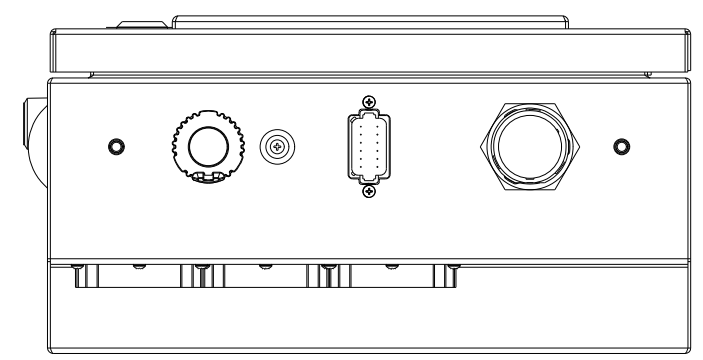
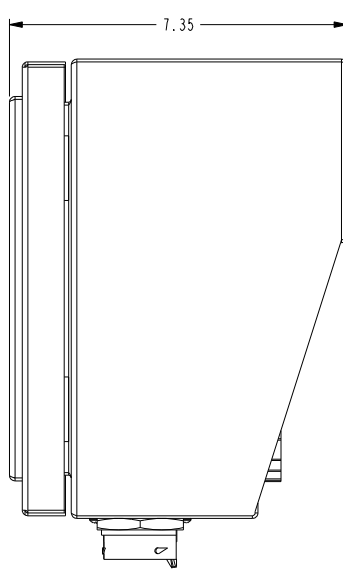
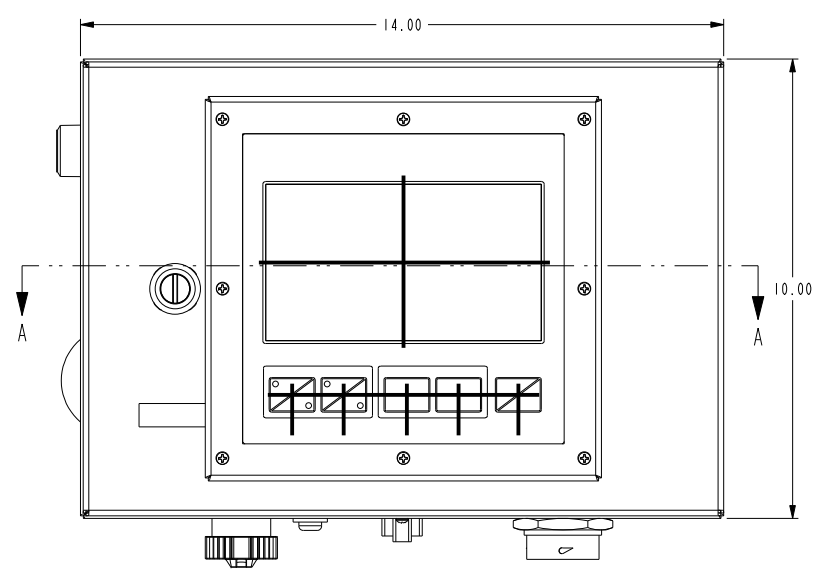
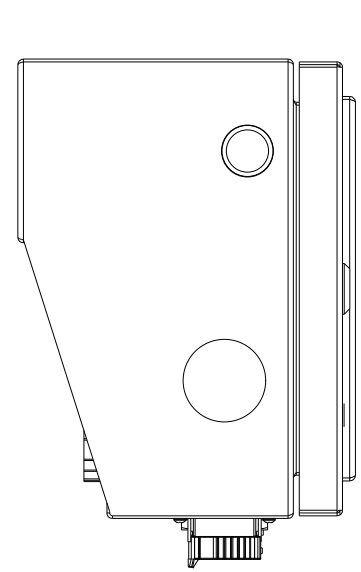
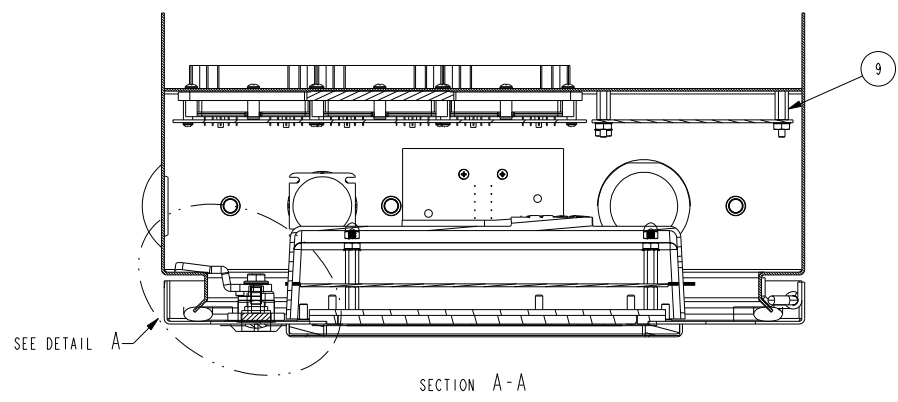
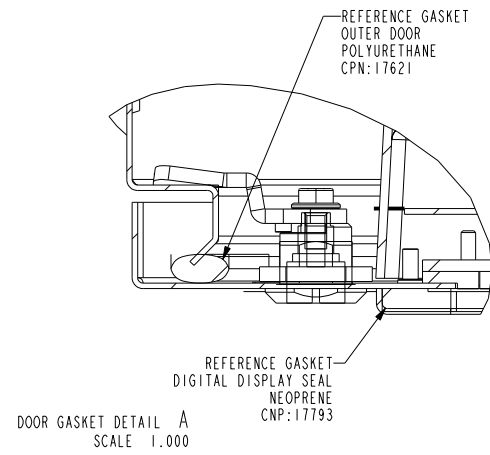

BILL OF MATERIAL			
ITEM	QTY	DESCRIPTION	PART NUMBER
1	1	POWER MODULE ECM , DIGITAL PANEL, ELECTRONIC	15155
2	1	ASSY, WIRING, DIGITAL PANEL, ENGINE STOP SWITCH	15160
3	1	DIAGNOSTICS, DIGITAL PANEL, RECEPTACLE AND CABLE	A042G193
4	1	ASSY,BULKHEAD WIRING, DIGITAL PANEL, BULKHEAD TO POWER PCB	A042G197
5	1	CABLE, DIGITAL PANEL, POWER PCB TO DISPLAY PCB	A042G198
6	1	SWITCH PCB, DIGITAL PANEL, MODULE, ECM	A042G207
7	1	CABINET, CONTROL PANEL	A042H232
8	1	BEZEL, FORMED, STEEL, CONTROL PANEL	15165
9	9	STANDOFF HEX M/F, 8-32, BRASS .63"L	15579
10	6	STANDOFF HEX M/F, 8-32, BRASS .75"L	15580
11	14	NUT, 8-32, W/TOOTH WASHER, ZNC -PLTD	15582
12	1	PLUG, LIQUID TIGHT, HEYCO, 3B37	15645
13	4	NUT, ACORN, SELF-LOCKING, 8-32, 18-8 STNL STL	17149
14	2	STANDOFF HEX M/F, 8-32, BRASS 1.25"L	17205
15	1	BEZEL, GASKET 1/4" x 3/4"	17793
16	1	TIE, WIRE, 4", NATURAL	3M101M-ND
17	1	SCREW, 1/4-20 STAINLESS STEEL	91772A537
18	1	WASHER, 1/4" STAINLESS STEEL	93852A102
19	8	SCREW, 6-32, 1/2" LONG , STAINLESS STEEL, BLACK OXIDE FINISH	96640A117
20	20	SCREW, 8-32, 1/2" LONG , STAINLESS STEEL	99461A240
21	1	MEMBRANE, KEYPAD	A042G192
22	1	COVER, DOOR PANEL	A042G194
23	1	PCB, DIGITAL PANEL, ELECTRONIC	A042G195
24	1	POWER PCB, DIGITAL PANEL, ELECTRONIC	A042G196
25	1	DISPLAY, COLOR TOUCH SCREEN	A042G199
26	1	STRAP, GROUND	A042G200
27	1	CABLE, DIGITAL PANEL, POWER PCB TO ECM SWITCH PCB	A042G202
28	1	LABEL, UL , ELECTRONIC CONTROL PANEL	A042G204
29	1	BEZEL, DISPLAY MOUNTING, FIRE PUMP DIGITAL PANEL	A042H037
30	1	COVER, DISPLAY, FIRE PUMP DIGITAL PANEL	A042H565
31	1	SWITCH, PUSHBUTTON, ABB CONTROL, CP110R-01	CP110R-01
32	1	CLIP, RIBBON CABLE, 25.6mm	FCM1-A-C14
33	1	COVER, HD10 W/LANYARD, DEUTSCH	HDC16-9-E004-L47N
34	1	HOLDER, TIE, ADHESIVE, NATURAL	RP302-ND

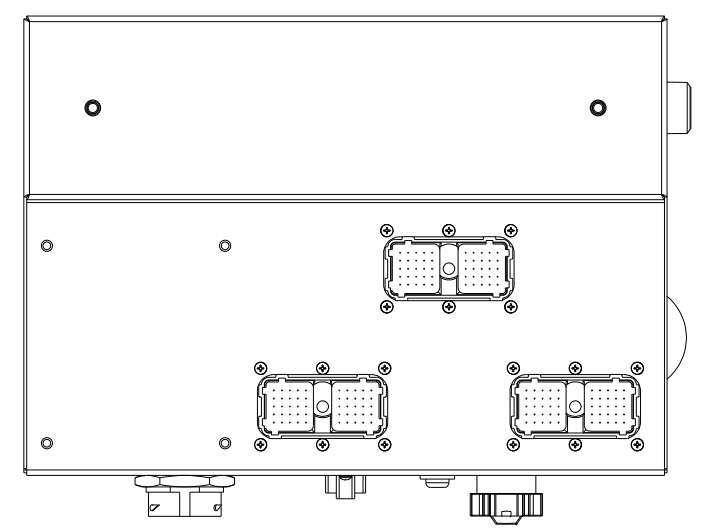

NOTES:
1. TYPE 4X INDOOR USE CONSTRUCTION
2. UPDATED SOFTWARE

This document contains confidential and trade secret information, is the property of Cummins Fire Power LLC and is to be used only for the intended purpose. The recipient of this document is authorized to use the information contained herein for the intended purpose only. Any other use, including copying, distribution, or disclosure, is strictly prohibited. If you are not the intended recipient, you should not disseminate, distribute or take any action in reliance on the information in this document. If you have received this document in error, please notify the sender immediately by e-mail at info@cumminsfirepower.com and delete this document from your system. ©2016 Cummins Fire Power LLC

Fire Power
CUMMINS FIRE POWER LLC
CORPORATE OFFICE
1600 BLUEBELL ROAD
WHITE BEAR LAKE, MN
WWW.CUMMINSFIREPOWER.COM

CUSTOM DESIGN
AND UPFIT CENTER
875 LAWRENCE DRIVE
DEPERE, WISCONSIN

UNLESS OTHERWISE SPECIFIED ALL DIMENSION TOLERANCES ARE		ANGULAR DIMENSIONS ± 1°		FINISH ANGLE PROJECTION		MACHINED SURFACES		IMPERIAL UNITS		METRIC UNITS		DWG UNITS:		DRAWN BY: PBS		DATE: 14SEP2016	
± 0.005		± 0.005		± 0.005		± 0.005		IN/LB/S		MM/KG		IN/LB/S		PRO-ENGINEER		INIT ECO: 2016-376	
A		2017-057		UPDATED PER A042H232		PBS		01FEB2017		SCALE: 0.500		SHEET 1 OF 2		DRAWING NO: A042G185		EST WEIGHT: 28.994	
REV		ECO		DESCRIPTION OF REVISION		REV BY		DATE									

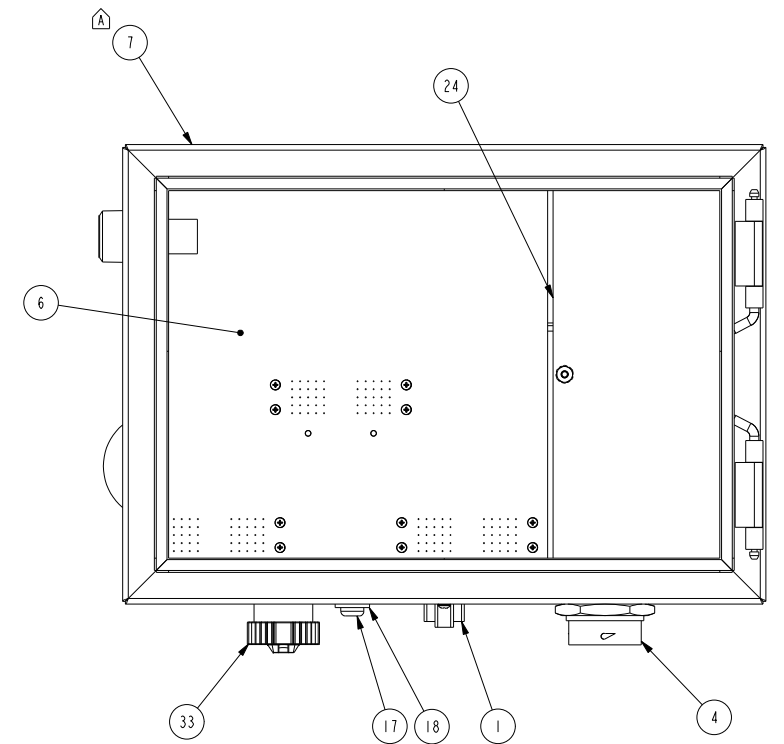
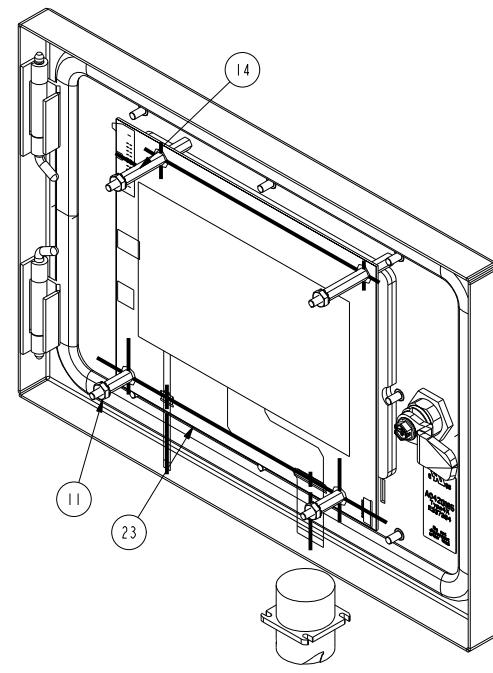
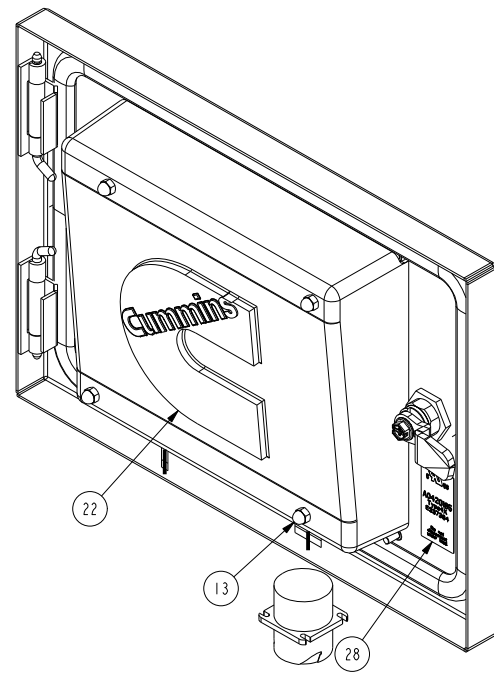
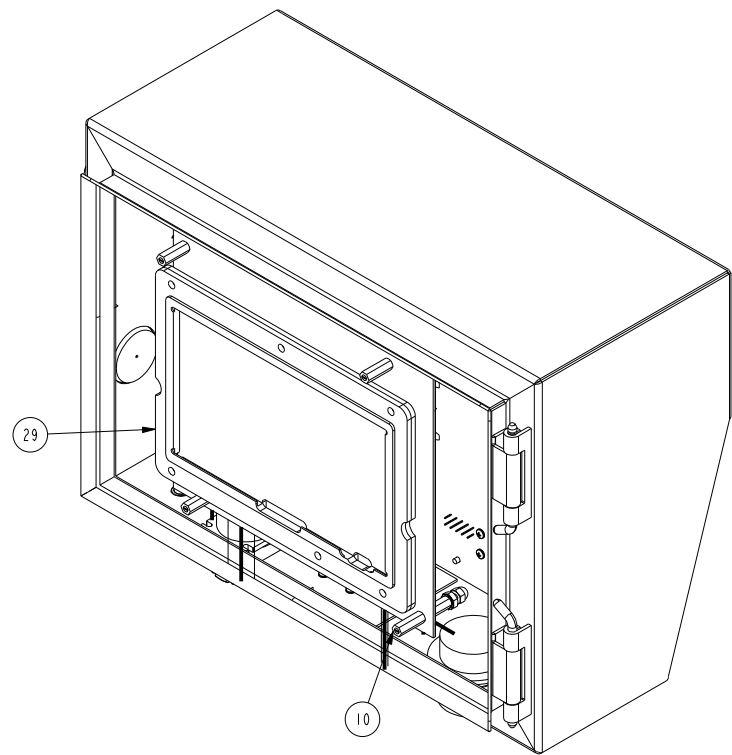
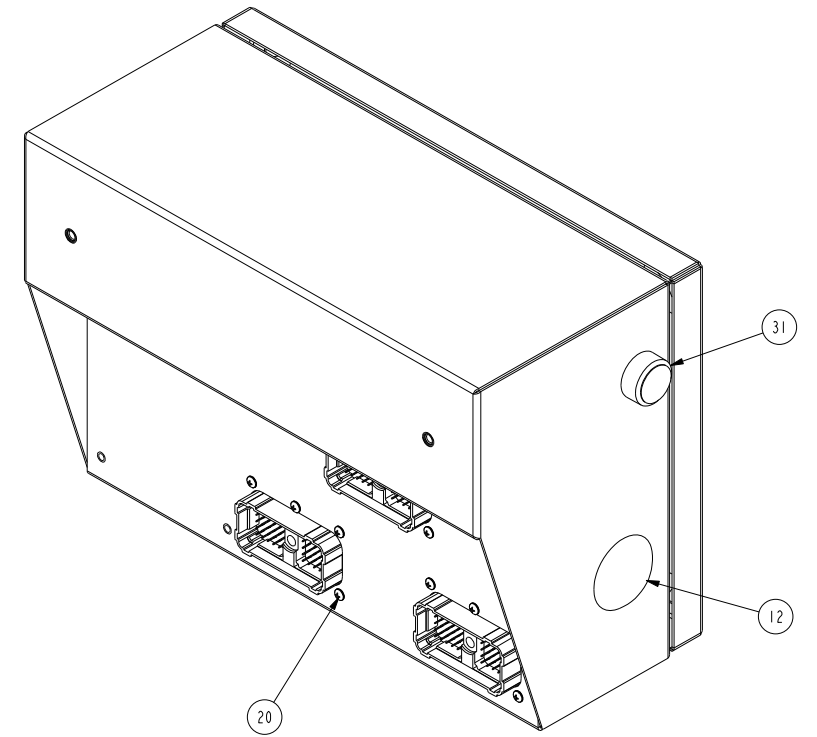
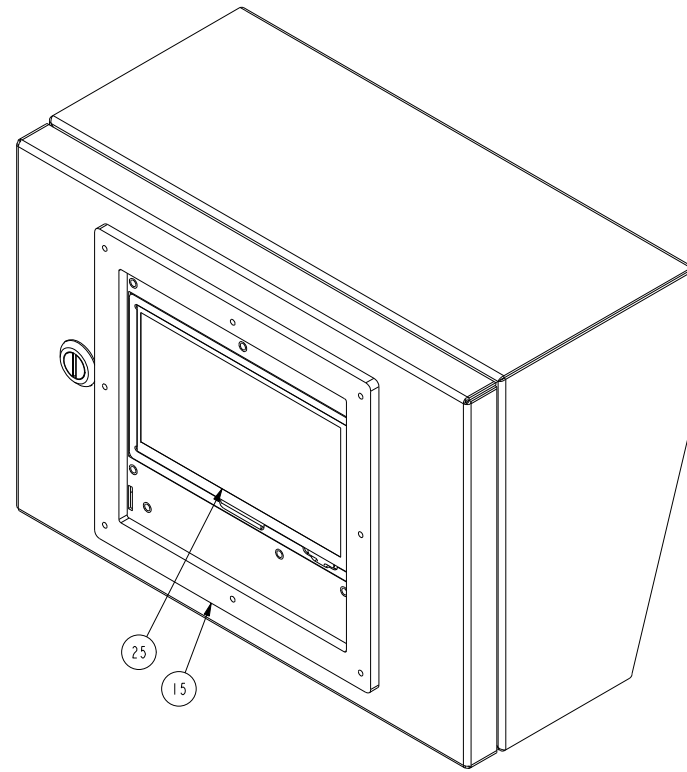
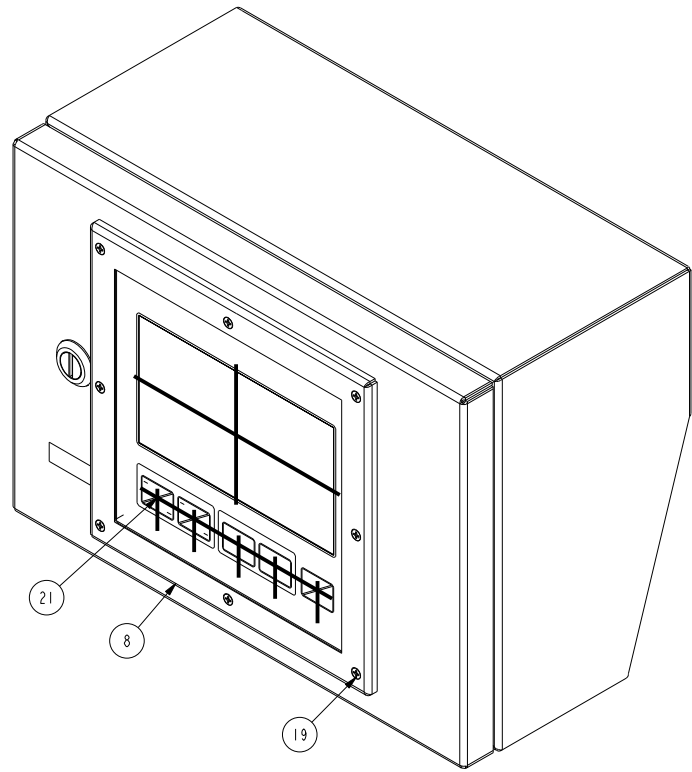

This document contains confidential and trade secret information, is the property of Cummins Fire Power, LLC and is to be used only for the purposes intended. The recipient of this document shall not disclose or use the information contained herein for any other purpose without the prior written consent of Cummins Fire Power, LLC. If you are not an intended recipient, you should not disseminate, distribute or copy this document. If you have received this document by mistake, please notify the sender immediately by e-mail at comms@firepower.com and delete this document from your system. If you are an intended recipient, you should not disseminate, distribute or copy this document without the prior written consent of Cummins Fire Power, LLC.

UNLESS OTHERWISE SPECIFIED ALL DIMENSION TOLERANCES ARE ANGULAR DIMENSIONS ± 1° MACHINED SURFACES IMPERIAL UNITS METRIC UNITS

125

ASSEMBLY, DIGITAL CONTROL PANEL
ELECTRONIC CFP ENGINES

Fire Power CUMMINS FIRE POWER LLC
CORPORATE OFFICE
1600 BUECKLE ROAD
WHITE BEAR LAKE, WI
WWW.CUMMINSFIREPOWER.COM

CUSTOM DESIGN
AND OPTIC CENTER
875 LAWRENCE DRIVE
DEPERE, WISCONSIN

DWG UNITS: IN/LB/S
SCALE: 0.500
EST WEIGHT: 28.994

DRAWN BY: PBS
PRO-ENGINEER
SHEET 2 OF 2

DATE: 14SEP2016
INIT ECO: 2016-376
DRAWING NO: A042G185

REV	ECO	DESCRIPTION OF REVISION	REV BY	DATE
A	2017-057	SEE SHEET 1 FOR LATEST REVISION DETAILS	PBS	01FEB2017

BILL OF MATERIAL

ITEM	QTY	DESCRIPTION	PART NUMBER
1	1	CONTACTOR, MANUAL OVERRIDE, 12V, PN:535-0127, FIREPUMP	8824-12
2	1	CONTACTOR, MANUAL OVERRIDE, 24V, PN:535-0098, FIREPUMP	8824-24

1 2 3 4 5 6 7

PRO0010

DESIGN APPROVAL DATE UNspecified TOLERANCES
 DES.ENG. J.W. ±.005
 MFG.ENG. J. Machine Finish ±.010
 Q.C. Angles ±1°
 SALES Concentricity .005 TIR
 Sqaureness .001 per ft.

This Drawing is the property of the Dumore Corporation. It must not be reproduced or copied without written permission.

PART NO. 535-0127
DUMORE CORPORATION
 1030 VETERANS ST. MAUSTON, WI 53948

DO NOT SCALE DRAWING REMOVE ALL BURRS BREAK SHARP CORNERS
 TITLE ASSEMBLY, SOLENOID

MATERIAL SPEC: Rec. per Piece Pattern No. RECEIVED AS DWG. BY CTH DATE 7/19/01 SCALE 1:2
 Q.C. BY DATE

REVISIONS
 RELEASED ECN # 25159 7/19/01 CTH

THE 535-0127 SOLENOID ASSEMBLY MUST BE INSTALLED IN A NEMA 2 ENVIRONMENT

ELECTRICAL SPECIFICATIONS
 VOLTS: 12 VDC
 CONTACT RATING: 400 AMPS (ROLLING CURRENT)
 800 AMPS (BREAKAWAY CURRENT)
 DUTY TYPE: INTERMITTENT
 CONTACT POSITION: NORMALLY OPEN

WHERE USED

3.00 ± .06
 2.34 ± .03
 17° - 20°
 5.74
 2.65 ± .03
 .275
 .255 TYP (4)
 .50 1.75
 6.00 ± .03

30° 30°
 10-32 UNF-2A THREAD TYP.(2)
 3/8-16 UNC-2A THREAD TYP.(2)
 U.L. & FACTORY MUTUAL DECAL.
 1.99 ± .03 TYP.
 1.90
 .354
 .334
 1.50
 3.00
 3.63 ± .03
 4.88 ± .06
 .28

ITEM:1 - 8824-12

1 2 3 4 5 6 7

SP4847

DESIGN APPROVAL DATE UNspecified TOLERANCES
 DES.ENG. J.W. ±.005
 MFG.ENG. J. Machine Finish ±.010
 Q.C. Angles ±1°
 SALES Concentricity .005 TIR
 Sqaureness .001 per ft.

This Drawing is the property of the Dumore Corporation. It must not be reproduced or copied without written permission.

PART NO. 535-0098
DUMORE CORPORATION
 1030 VETERANS ST. MAUSTON, WI 53948

DO NOT SCALE DRAWING REMOVE ALL BURRS BREAK SHARP CORNERS
 TITLE ASSEMBLY, SOLENOID

MATERIAL SPEC: Rec. per Piece Pattern No. RECEIVED AS DWG. BY MED DATE 2/16/89 SCALE 1:2
 Q.C. BY DATE 8/13/91

REVISIONS

THE 535-0098 SOLENOID ASSEMBLY MUST BE INSTALLED IN A NEMA 2 ENVIRONMENT

ELECTRICAL SPECIFICATIONS
 VOLTS: 24 VDC
 CONTACT RATING: 400 AMPS (ROLLING CURRENT)
 800 AMPS (BREAKAWAY CURRENT)
 DUTY TYPE: INTERMITTENT
 CONTACT POSITION: NORMALLY OPEN

3.00 ± .06
 2.34 ± .03
 17° - 20°
 5.74
 2.65 ± .03
 .275
 .255 TYP (4)
 .50 1.75
 6.00 ± .03

30° 30°
 10-32 UNF-2A THREAD TYP.(2)
 3/8-16 UNC-2A THREAD TYP.(2)
 U.L. & FACTORY MUTUAL DECAL.
 1.99 ± .03 TYP.
 1.90
 .354
 .334
 1.50
 3.00
 3.63 ± .03
 4.88 ± .06
 .28

ITEM:2 - 8824-24

REV	ECO	DESCRIPTION OF REVISION	REV BY	DATE
A	2011-068	UPDATED DRAWING FORMAT ADDED CNP LABEL TO PDF DRAWING	MAC	18FEB2011

This document contains confidential and trade secret information, is the property of Cummins Fire Power LLC and is given to the receiver in confidence. The receiver, by receiving and retaining of the document accepts the document in confidence and agrees that, except as authorized in writing by Cummins Fire Power, it will (1) not use the document or any copy thereof or the confidential or trade secret information therein, (2) not copy the document, (3) not disclose to others either the document or the confidential or trade secret information therein, and (4) upon completion of the need to retain the document, or upon demand, return the document, all copies thereof, and all material copied therefrom. COPYRIGHT Cummins Fire Power LLC

Cummins Fire Power

CUMMINS FIRE POWER LLC
 CORPORATE OFFICE
 1600 BUERKLE ROAD
 WHITE BEAR LAKE, MN
 WWW.CUMMINSFIREPOWER.COM

CUSTOM DESIGN AND UPFIT CENTER
 875 LAWRENCE DRIVE
 DEPERE, WISCONSIN

MANUAL SOLENOID

UNLESS OTHERWISE SPECIFIED ALL DIMENSION TOLERANCES ARE

ANGULAR DIMENSIONS ± 1°	IMPERIAL UNITS	METRIC UNITS
THIRD ANGLE PROJECTION	MACHINE TOLERANCES .XX ± 0.010 .XX ± 0.005 FOM TOLERANCES .XX ± 0.020 .XX ± 0.015 FAB TOLERANCES .XX ± 0.080 .XX ± 0.030	MACHINE TOLERANCES .XX ± 0.2 .XX ± 0.1 FOM TOLERANCES .XX ± 0.8 .XX ± 0.4 FAB TOLERANCES .XX ± 1.5 .XX ± 0.8

DWG UNITS: IN/LB/S
 DRAWN BY: CMC
PRO-ENGINEER
 SCALE: 1.000
 EST WEIGHT: 42238.628

DATE: 12JUNE2004
 INIT ECO: -
 SHEET 1 OF 1
 DRAWING NO: 8824

BILL OF MATERIAL			
ITEM	QTY	DESCRIPTION	PART NUMBER
1	1	HOSE, FUEL COOLER INPUT, CFPI5E	12523
2	1	LINE, FUEL RETURN, CFPI5E	A042J766
3	2	PLUG. PIPE, -12 NPT	12210-12
4	2	FTG, STR, -10 JIC X -12 FMNPT	12240-10-12
5	4	CLAMP, LOOM, 1.00 ID	26963-16
6	1	CLAMP, LOOM, 1.00 ID	26964-16

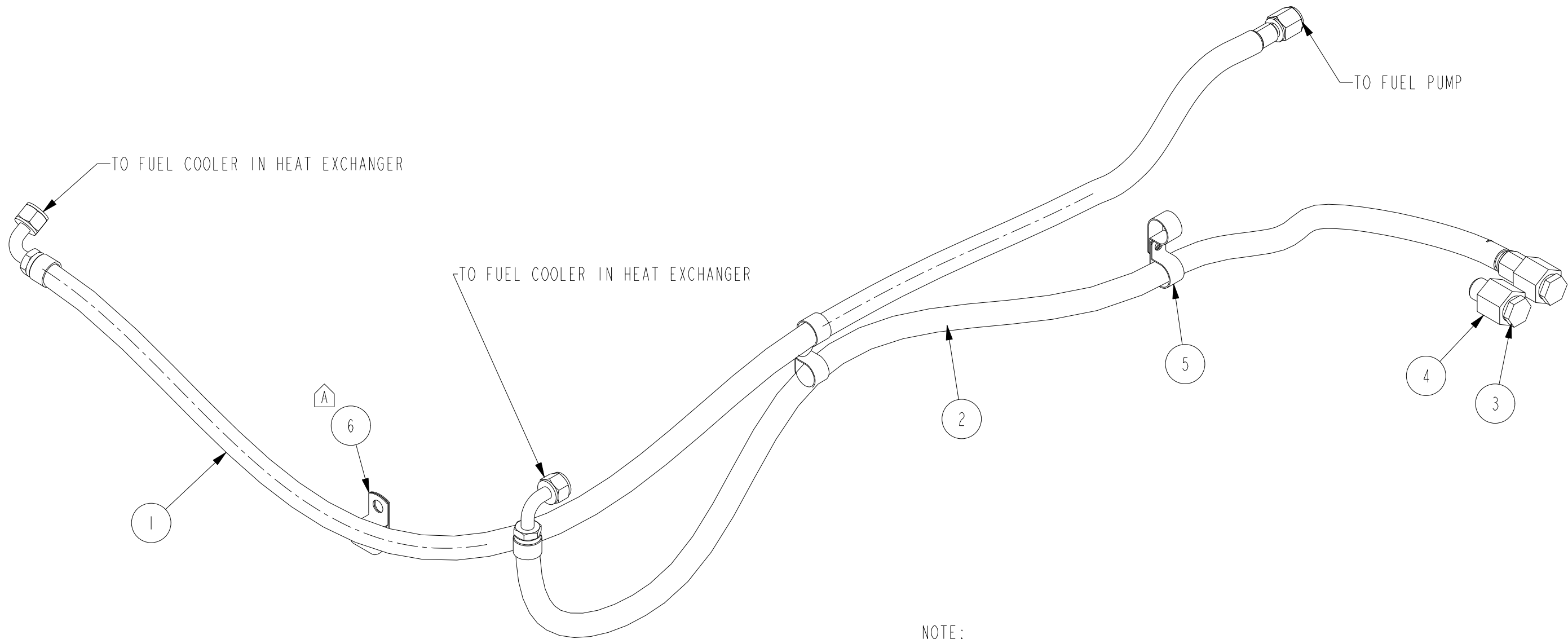

NOTE:
1. SEE ASSEMBLY DRAWING A042H685 OR A042H686 FOR INSTALLATION ON ENGINE

<small>This document contains confidential and trade secret information, is the property of Cummins Fire Power LLC and is given to the receiver in confidence. The receiver, by receiving and retaining of the document accepts the document in confidence and agrees that, except as authorized in writing by Cummins Fire Power, it will (1) not use the document or any copy thereof or the confidential or trade secret information therein, (2) not copy the document, (3) not disclose to others either the document or the confidential or trade secret information therein, and (4) upon completion of the need to retain the document, or upon demand, return the document, all copies thereof, and all material copied therefrom. COPYRIGHT Cummins Fire Power LLC</small>		CUMMINS FIRE POWER LLC CORPORATE OFFICE 1600 BUERKLE ROAD WHITE BEAR LAKE, MN WWW.CUMMINSFIREPOWER.COM	CUSTOM DESIGN AND UPFIT CENTER 875 LAWRENCE DRIVE DEPERE, WISCONSIN
UNLESS OTHERWISE SPECIFIED ALL DIMENSION TOLERANCES ARE			
ANGULAR DIMENSIONS ± ° THIRD ANGLE PROJECTION	MACHINED SURFACES 	IMPERIAL UNITS .XX : ± 0.010 .XXX : ± 0.005 FOM TOLERANCES .XX : ± 0.030 .XXX : ± 0.015 FAB TOLERANCES .XX : ± 0.060 .XXX : ± 0.030	METRIC UNITS .XX : ± 0.2 .XX : ± 0.1 FOM TOLERANCES .XX : ± 0.4 .XX : ± 0.5 FAB TOLERANCES .XX : ± 0.8 .XX : ± 0.8
REV A 2018-114 ADD: 26964-16 CHANGE QUANTITY: 26963-16 WAS 5	HE392 28FEB18	DWG UNITS: IN/LB/S SCALE: 0.250 EST WEIGHT: 0.000	DRAWN BY: PBS PRO-ENGINEER SHEET 1 OF 1 DATE: 19JAN2017 INIT ECO: 2016-668 DRAWING NO: A042J765

REV	ECO	DESCRIPTION OF REVISION	REV BY	DATE
A	2018-114	ADD: 26964-16 CHANGE QUANTITY: 26963-16 WAS 5	HE392	28FEB18

BILL OF MATERIAL			
ITEM	QTY	DESCRIPTION	PART NUMBER
1	2	BUSHING, REDUCING PIPE; -12 NPT X -2 FNPT, STEEL	12176-12-2
2	2	FTG. TEE, RUN; -12 NPT	12204-12
3	2	PLUG, PIPE; EXT HEX -12 NPT, STEEL	12210-12
4	2	PLUG, PIPE; EXT HEX -2 NPT, STEEL	12210-2
5	2	CONNECTOR, FEMALE; -10 JIC X -12 FNPT, STEEL	12240-10-12
6	1	HOSE, FUEL COOLER INPUT; CFP15E	12523
7	3	CLIP; 1.00 ID, 3/8" HOLE, VINYL	26963-16
8	1	CLAMP, LOOM; 1/2" BOLT HOLE, VINYL	26964-16
9	1	LINE, FUEL RETURN; CFP15E	A042J766

REV	REL NO	REVISION	DWN	CKD	APVD	DATE
-	2016-668	INITIAL RELEASE	PBS	-	-	19JAN17
A	2018-114	ADDED 26964-16; REMOVED 26963-16 QTY(1)	PBS	-	-	28FEB18
3	2020-348	ADDED 12204-12, 12176-12-2, 12210-2 & VIEW; REMOVED 26963-16 QTY(1) & NOTES	KMS	JJW	JJW	05OCT20

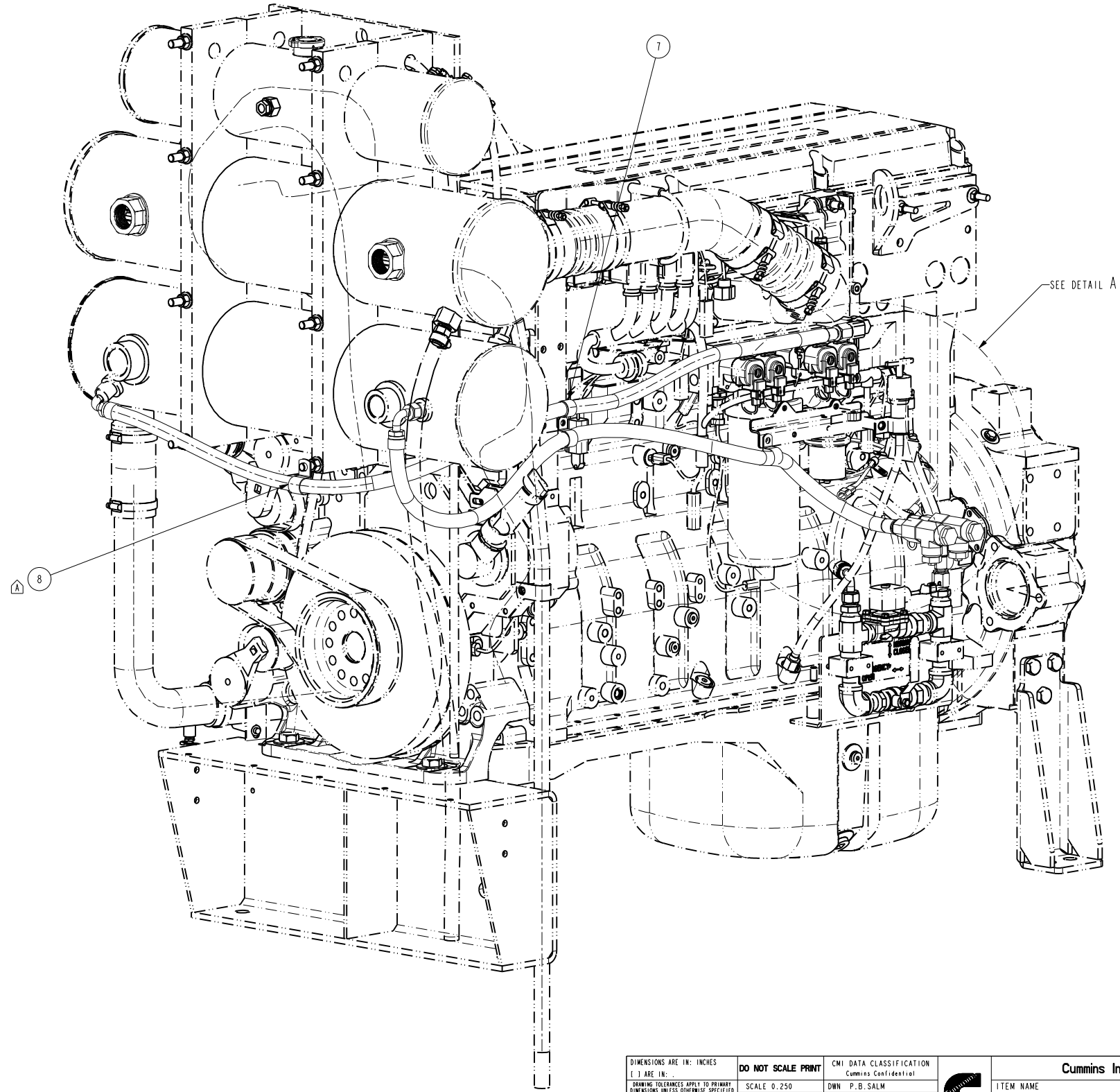
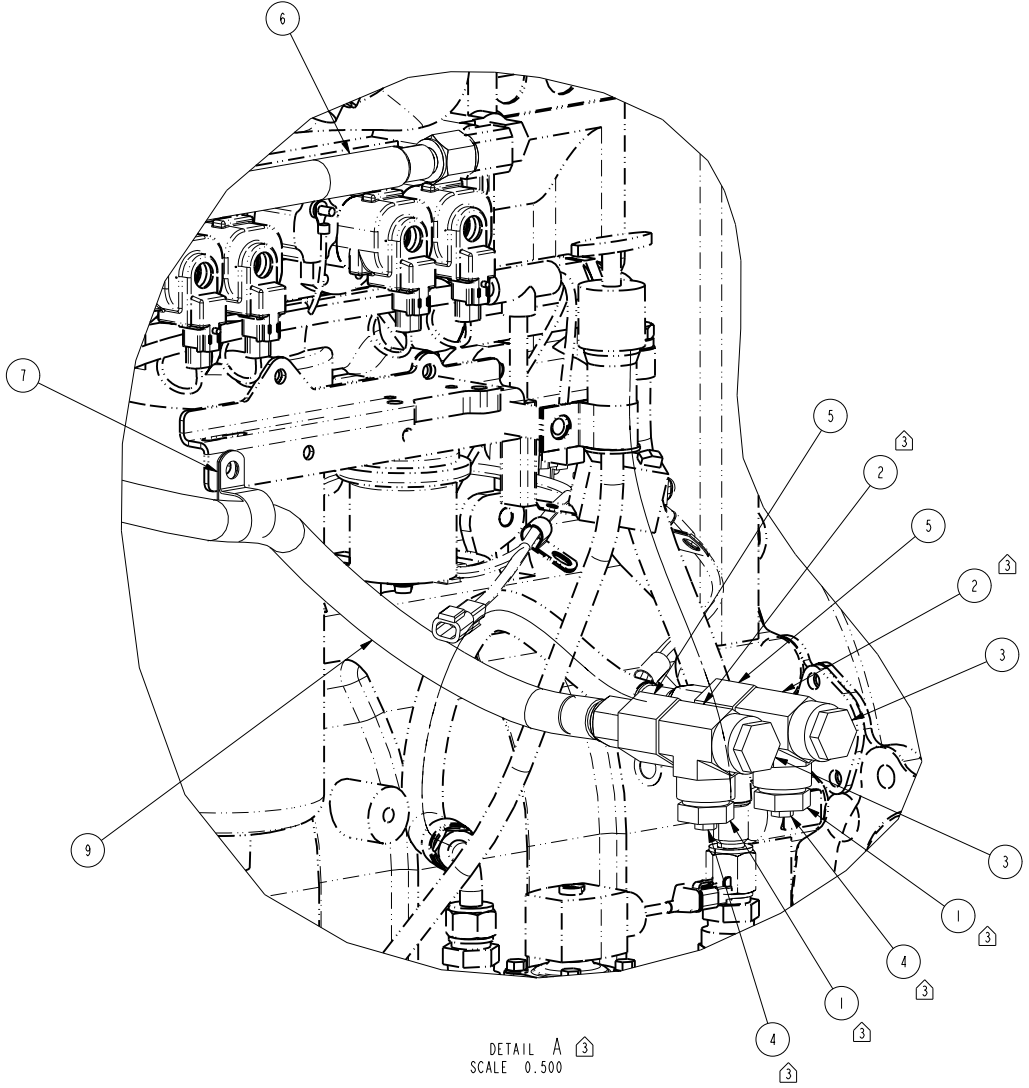

DIMENSIONS ARE IN: INCHES 1:1 ARE IN: DRAWING TOLERANCES APPLY TO PRIMARY DIMENSIONS UNLESS OTHERWISE SPECIFIED	DO NOT SCALE PRINT SCALE 0.250	CMI DATA CLASSIFICATION Cummins Confidential		Cummins Inc.			
<small> F1: ± 0.004 IN OR 0.10 mm F2: ± 0.003 IN OR 0.075 mm F3: ± 0.002 IN OR 0.050 mm F4: ± 0.001 IN OR 0.025 mm ANGULAR TOLERANCE: ± 0.005 IN </small>	<small> DWN: P.B. SALM CKD: APVD: DATE: 19 JAN 2017 </small>	<small> FOR INTERPRETATION OF DIMENSIONING AND TOLERANCING, SEE ASME Y14.5-2009 </small>		<small> MUST CONFORM TO CES 10903 </small>	<small> ITEM NAME ASSEMBLY, FUEL LINE CFP15E </small>	<small> CAD SHEET 1 OF 1 </small>	<small> ITEM NUMBER A042J765 </small>

J H G F E D

BILL OF MATERIAL

ITEM	QTY	DESCRIPTION	PART NUMBER
1	3	SPACER, MOUNTING, SECONDARY ECM;	9508
2	2	FTG, STR; -10 JIC X -12 NPT	12238-10-12
3	1	ASSEMBLY, HOSE, FUEL LINE; CFPI5E SUPPLY	15280
4	1	ASSEMBLY, HOSE, FUEL LINE; CFPI5E SUPPLY	15280
5	1	BRACKET, FUEL VALVE BYPASS;	18502
6	1	DECAL, FUEL VALVE BYPASS;	18505
7	2	CLAMP, 3/4" PIPE; PARKER, 4266-PP	24251
8	1	VALVE, SOLENOID, 3/4" NPT; QSX15 FSO,24VDC	A058N975
9	2	UNION, BLK, 3/4" NPT;	BI50UF
10	1	VALVE, BALL; 3/4" NPT	FA60406
11	3	SCREW, CAP, HEX HEAD, M10-1.5 x 70;	HHCS_M10-70
12	3	SCREW, CAP, HEX HEAD, M10-1.5 x 90;	HHCS_M10-90
13	5	NIPPLE, BLK, 3/4x1-1/2;	LTL-CPN34
14	1	NIPPLE,PIPE,0.75 NPT X 2.00; -	LTL-CPN342
15	2	NIPPLE, 3/4 X 3, BLK;	LTL-CPN343
16	2	ELBOW, BLK, 3/4" NPT, 90 DEG.;	LTL-E3490
17	2	TEE, BLK, 3/4" NPT;	LTL-ST34
18	3	WASHER, M10;	WASHER_M10

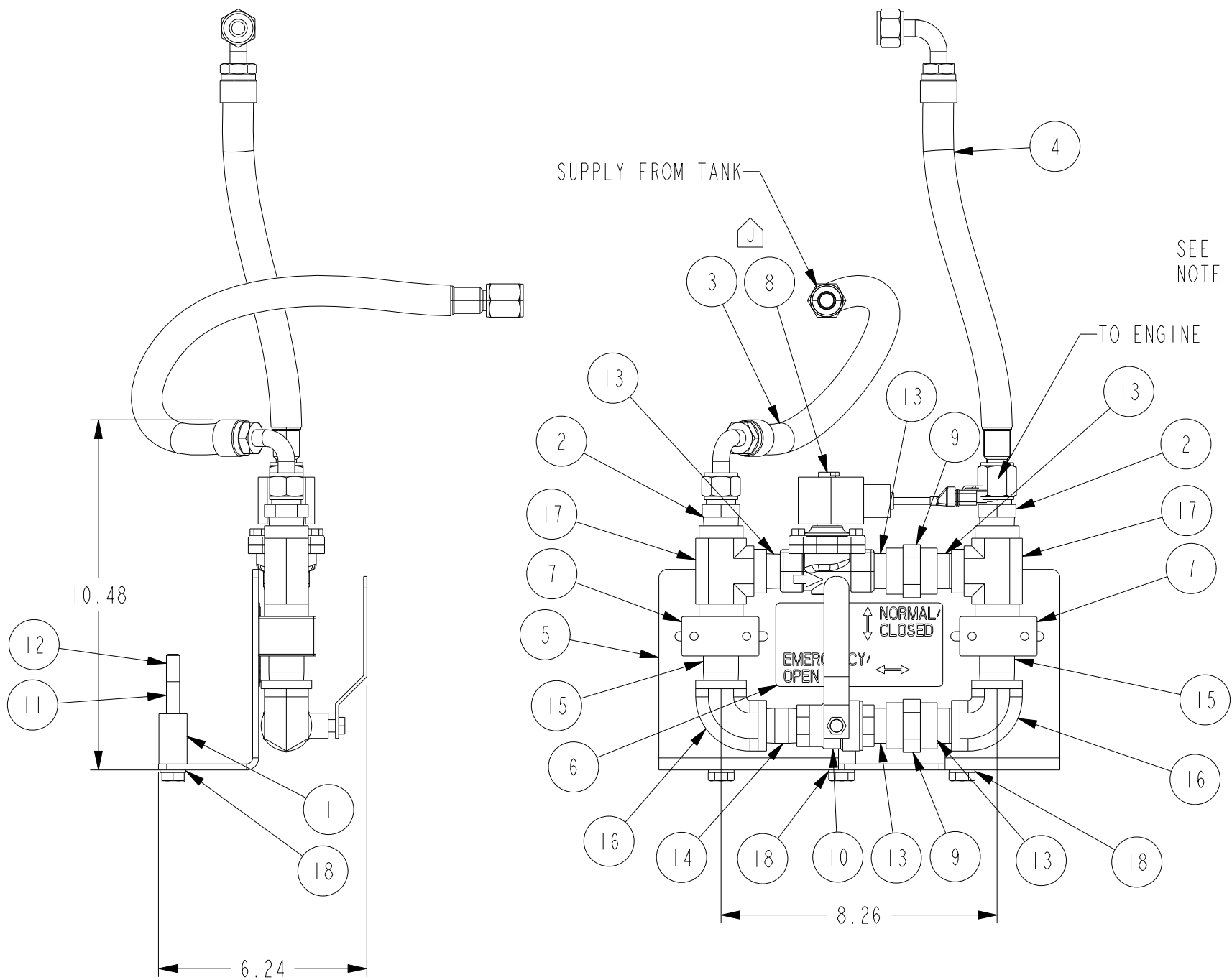

- A** NOTES:
1. PAINT PLUMBING COMPONENTS, EXCLUDE SOLENOID AND VALVE HANDLES.
 2. FINISH: CUMMINS RED PER SPEC ES044.
 3. PLUG ALL OPEN PORTS PRIOR TO SHIPPING.
 4. 90mm CAP SCREW USED ON HHP; 70mm CAP SCREW USED ON LHP

REV	ECO	DESCRIPTION OF REVISION	REV BY	DATE
J	2017-665	OMIT 18527;REPLACED A058N975 WAS 18503;OMIT HARNESS INSTALL NOTES	OY256	20NOV2017
H	2015-480	ADDED HEAT SHINK TUBING NOTE	KMS	04AUG2015
G	2014-608	12238-10-12 WAS 12238-12-12;9508 WAS A042A456	JJW	28AUG2014
F	2014-112	A042A456 WAS 9508	PBS	18FEB2014
E	2013-038	24251 WAS 14926	PBS	23JAN2013
D	2012-077	10626-12-12 WAS 10626-10-12	PBS	15MAR2012
C	2011-174	REV PER HARNESS 18527. ADDED CAP SCREW	DAN	18MAY2011

TORQUE TO 41 FT/LB
SEE SERVICE MANUAL

This document contains confidential and trade secret information, is the property of Cummins Fire Power LLC and is given to the receiver in confidence. The receiver, by receiving and retaining of the document accepts the document in confidence and agrees that, except as authorized in writing by Cummins Fire Power, it will (1) not use the document or any copy thereof or the confidential or trade secret information therein, (2) not copy the document, (3) not disclose to others either the document or the confidential or trade secret information therein, and (4) upon completion of the need to retain the document, or upon demand, return the document, all copies thereof, and all material copied therefrom. COPYRIGHT Cummins Fire Power LLC

UNLESS OTHERWISE SPECIFIED ALL DIMENSION TOLERANCES ARE

ANGULAR DIMENSIONS ± °	MACHINED SURFACES	IMPERIAL UNITS	METRIC UNITS
THIRD ANGLE PROJECTION	125	MACHINE TOLERANCES .1xx : ± 0.010 .2xx : ± 0.005 FORM TOLERANCES .1x : ± 0.030 .2x : ± 0.015 FAB TOLERANCES .1x : ± 0.060 .2xx : ± 0.030	MACHINE TOLERANCES .1x : ± 0.2 FORM TOLERANCES .1x : ± 0.8 FAB TOLERANCES .1x : ± 1.0 .2x : ± 0.8

	CUMMINS FIRE POWER LLC CORPORATE OFFICE 1600 BUERKLE ROAD WHITE BEAR LAKE, MN WWW.CUMMINSFIREPOWER.COM	CUSTOM DESIGN AND UPFIT CENTER 875 LAWRENCE DRIVE DEPERE, WISCONSIN
	ASSEMBLY, FUEL VALVE AND BYPASS	
DWG UNITS: IN/LB/S	DRAWN BY: DAN PRO-ENGINEER	DATE: 30-MAR-11 INIT ECO: 2011-112
SCALE: 0.250 EST WEIGHT: 18.753	SHEET 1 OF 1	DRAWING NO: 18501

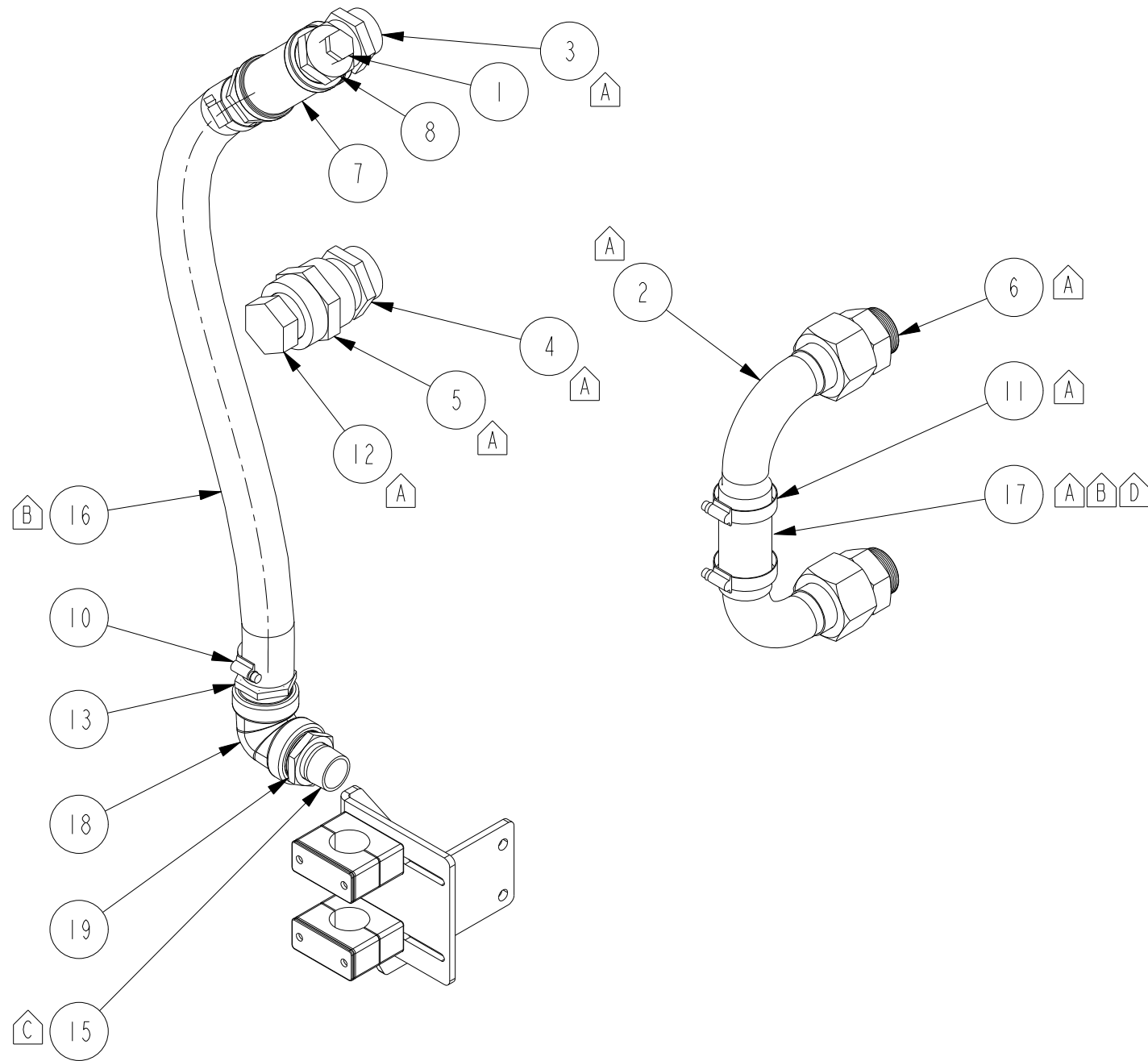

D C B A

BILL OF MATERIAL			
ITEM	QTY	DESCRIPTION	PART NUMBER
1	1	PLUG, ZINC W/ BRASS SUPPORT, 1/2" NPT; CHAMP #500129	9750
2	2	ELBOW, RAW WATER, FLARE X HOSE BEAD; STEEL, HX TO HX	10905
3	1	FTG, ORB (M) x NPT (M); 20-1 1/4	12163-20-20
4	1	FTG, ORB (M) x NPT (M); 24-1 1/2	12163-24-24
5	1	COUPLING, ZINC PLATED STEEL; 1 1/2 x 1 1/4	12168-24-20
6	2	ADAPTER, MALE JIC 37 DEG X MALE SAE ORB; -24-20	12235-24-20
7	1	TEE, 1 1/4" NPT FEMALE; DO NOT USE. USE BTH (18AUG2015)	12386
8	1	FITTING, REDUCER; 1 1/4 MALE NPTF X 1/2 FEMALE NPTF	12710
9	4	CLAMP, PIPE, 1", PLASTIC; W/COVER PLATE	14925-01
10	2	CLAMP, WORM; .81 - 1.75	14990-20
11	2	CLAMP, WORM; 1.06-2	14990-24
12	1	PLUG, NPT, PLASTIC; -20 (1-1/4") NPT	15255-20
13	2	ADAPTER, STEEL, NPT X BARB; 1-1/4" NPT X 1-1/4" BARB	16766-20-20
14	2	BRACKET, LH COOLING LOOP; CFPI5E	26478
15	1	NIPPLE, 1" NPT PIPE; 1.50" LONG	26969_0150
16	1	HOSE, 1-1/4IN IDx36IN; CUT TO 28.00IN LONG	A042F062
17	1	HOSE, 1.5" ID 4PLY, SILICONE; 4.00" LONG	A058N324
18	1	ELBOW, 90°, 1 1/4" NPT FEMALE; BLK STEEL	B90H
19	1	BUSHING, 1-1/4x1NPT; BLACK PIPE	BBHG

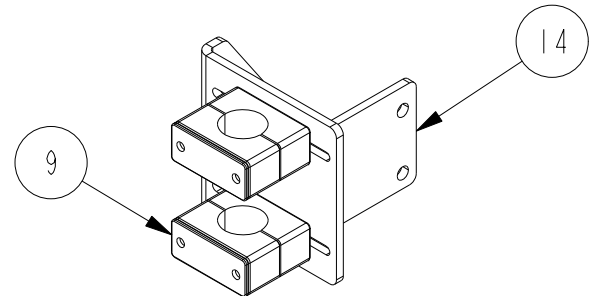

REV	ECO	DESCRIPTION OF REVISION	REV BY	DATE
D	2017-528	REPLACED A042F063 W/ A058N324	KMS	29AUG2017
C	2016-373	REPLACED LTL-CPNI W/ 26969_0150	KMS	07JUL2016
B	2016-048	REPLACED A042F062 WAS 78125GL REPLACED A042F063 WAS 78150GL	MRH	19JAN2016
A	2014-328	ADDED: 10905, 12235-24-20, 12163-20-20, 78150GL-004 12163-24-24, 12168-24-20, 14990-24, 15255-20	PBS	14JUL2014

This document contains confidential and trade secret information, is the property of Cummins Fire Power LLC and is given to the receiver in confidence. The receiver, by receiving and retaining of the document accepts the document in confidence and agrees that, except as authorized in writing by Cummins NPower, it will (1) not use the document or any copy thereof or the confidential or trade secret information therein, (2) not copy the document, (3) not disclose to others either the document or the confidential or trade secret information therein, and (4) upon completion of the need to retain the document, or upon demand, return the document, all copies thereof, and all material copied therefrom. COPYRIGHT Cummins Fire Power LLC



CUMMINS FIRE POWER LLC
CORPORATE OFFICE
1600 BUERKLE ROAD
WHITE BEAR LAKE, MN
WWW.CUMMINSFIREPOWER.COM

CUSTOM DESIGN
AND UPFIT CENTER
875 LAWRENCE DRIVE
DEPERE, WISCONSIN

UNLESS OTHERWISE SPECIFIED ALL DIMENSION TOLERANCES ARE

ANGULAR DIMENSIONS ± 1°	MACHINED SURFACES	IMPERIAL UNITS MACHINE TOLERANCES .XX ± 0.010 .XXX ± 0.005	METRIC UNITS MACHINE TOLERANCES .X ± 0.4 .XX ± 0.2
THIRD ANGLE PROJECTION	125	FORM TOLERANCES .XX ± 0.030 .XXX ± 0.015	FORM TOLERANCES .X ± 0.8 .XX ± 0.4
		FAB TOLERANCES .XX ± 0.050 .XXX ± 0.030	FAB TOLERANCES .X ± 1.5 .XX ± 0.8

MISCELLANEOUS PIPING
RAW WATER, CFPI5E

DWG UNITS: IN/LB/S	DRAWN BY: PBS PRO-ENGINEER	DATE: 22JAN2014 INIT ECO: 2013-705
SCALE: 0.200	SHEET 1 OF 1	DRAWING NO: A042A257
EST WEIGHT: 42238.628		

BILL OF MATERIAL			
ITEM	QTY	DESCRIPTION	PART NUMBER
1	1	SENDER, WATER TEMPERATURE; 1/8" NPT	8862
2	1	GAUGE, PRESSURE, 1/4" NPT; DPG1-2 1/2, 0-100 PSI, (WATTS)	8892
3	2	CONNECTOR, FEMALE; -4 NPT X M14 ORB, STEEL	12177-4-M14
4	2	VALVE, BALL, 1NPT; BRASS, LOCKABLE	21505
5	1	CROSS, INPT, STEEL; SCHEDULE 40 PIPE	21520
6	2	VALVE, 1" NPT CHECK; VALUE ADDED: CV100	25503
7	8	NIPPLE, PLAIN PIPE; -16 NPT X 1.50", BLACK	26969_0150
8	4	NIPPLE, PLAIN PIPE; -16 NPT X 3.50", BLACK	26969_0350
9	2	NIPPLE, PLAIN PIPE; -16 NPT X 6.00", BLACK	26969_0600
10	2	SEAL, METRIC BONDED; ADAPTALL 9500MM SERIES	26984-14
11	1	VALVE, BALL, 1/4" NPT FEMALE;	A042D838
12	2	REGULATOR, 1" NPT, 400 PSI MAX, 25 TO 75 PSI OUT;	A042D839
13	2	STRAINER, 1" NPT;	A042D840
14	2	PLUG, THREADED, M14x1.5; McMASTER-CARR: 5481N25	A060R226
15	4	BUSHING, REDUCER, 1" X 1/4" NPT; -	BB6B
16	1	NIPPLE, 1/4" NPT X 1 1/2"; BLK STEEL	LTL-CPN14112
17	1	ELBOW, 90°, 1" NPTF; BLK IRON	LTL-E190
18	2	PLUG, PIPE; 3/4 BIP COUNTERSUNK	LTL-SCSP34
19	1	REDUCER BUSHING, HEX; 1/4 X 1/8, BLK STEEL	LTL-SRB1418
20	4	TEE, BLK, 1";	LTL-ST1

REV	REL NO	REVISION	DWN	CKD	APVD	DATE
-	2016-376	INITIAL RELEASE	PBS			12SEP16
C	2018-360	DELETE: 12210-4; ADD: A060R226, 26984-14 & NOTE	HE392			03JUL18
4	2020-071	ADDED STRAINER SCREEN & O-RING NOTE	RE123	MS707	MS707	04FEB20

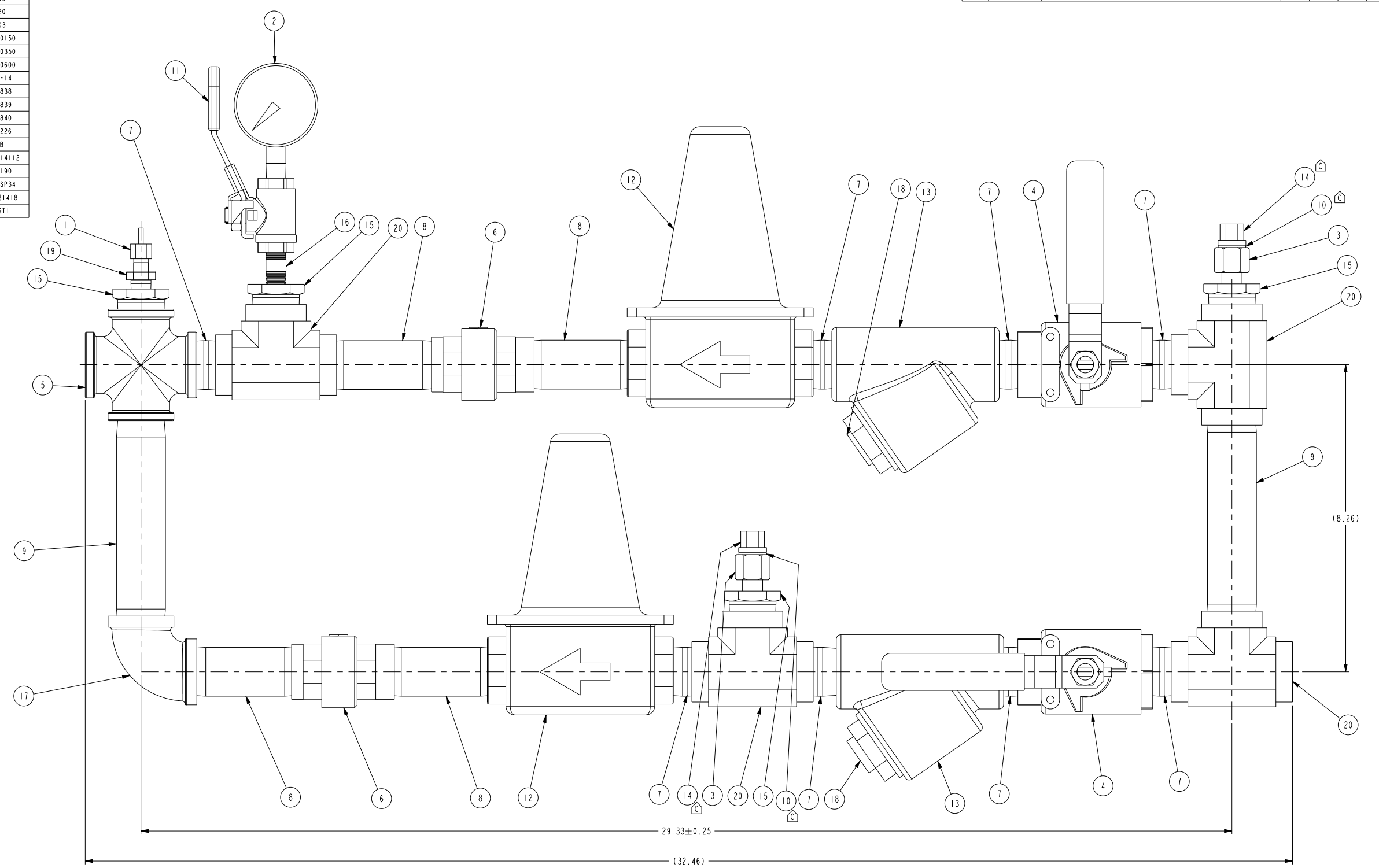

- NOTES:
- MATERIAL: SEE PARTS LIST
 - REMOVE ALL SHARP EDGES PRIOR TO COATING
 - LEAK TEST TO 60PSI AND PRESET REGULATORS TO 60PSI
 - FINISH: COAT PER CUMMINS SPEC ES044 RAL 3001
 - CAP ALL PORTS PRIOR TO SHIPPING
 - REPLACEMENT COMPONENTS FOR ITEM A042D840:
REPLACEMENT STRAINER SCREEN P/N: A0632528
REPLACEMENT O-RING P/N: A0632529

DIMENSIONS ARE IN: INCHES [] ARE IN: -	DO NOT SCALE PRINT SCALE 0.700	CMI DATA CLASSIFICATION Cummins Confidential		Cummins Inc.	
DRAWING TOLERANCES APPLY TO PRIMARY DIMENSIONS UNLESS OTHERWISE SPECIFIED X.1: ± 1 IN OR 4 mm X.2: ± 1 IN OR 3.7 mm X.3: ± .030 IN OR 0.25 mm X.4: ± .010 IN OR 0.25 mm ANGULAR TOLERANCE: ±	DATE 12SEP16	DWN PBS CKD - APVD -		ITEM NAME COOLING LOOP, 1", VERT RAW WATER	CAD SHEET 1 OF 2
THIS DOCUMENT AND THE INFORMATION SHOWN THEREON IS CONFIDENTIAL AND PROPRIETARY AND SHALL NOT BE DISCLOSED TO OTHERS IN HARD COPY OR ELECTRONIC FORM, REPRODUCED BY ANY MEANS, OR USED FOR ANY PURPOSE WITHOUT WRITTEN CONSENT OF CUMMINS INC.		FOR INTERPRETATION OF DIMENSIONING AND TOLERANCING, SEE ASME Y14.5-2009		MUST CONFORM TO CES 10903	REV 4

8	7	6	5	4	3	2	1
Assembly	Component	Manufacture/pn	Description	Sub-Component	Material	Specification	
A042H730	21505	RUB, S95F445	1" Vertical, Raw Water 1" ball valve				
				body	CW617N	EN12165	
				seat	PTFE		
				ball	CW617N	EN12165	
				end cap	CW617N	EN12165	
				stem	CW617N	EN12164	
				nut	CB4FF	EN10263-2	
				O-ring	FPM		
				handle	DD11	EN10111	
				handle coating	PVC		
				washer	PTFE		
A042D839	Watts, N45BU-M1-1"	regulator					
				body	brnze		
				seat	thermoplastic		
				cage	thermoplastic		
				integral strainer	stainless steel		
				diaphragm	reinforced EPDM		
				valve disc	elastomer		
A042D840	Watts, 77S-M1-1"	strainer					
				body	cast iron		
				retainer cap	cast iron	ASTM A-126 Class B	
				screen	304 stainless steel		
8862	Datcon 02022-00	temperature sender		Body	brass		
8892	Watts, DPG1-2	pressure gauge					
				case	ABS polymer		
				window	Kostil polymer		
				sensing element	copper alloy Bourdon tube		
				welding	tin alloy		
				connection	brass		
A042D838	RUB, S95B45	1/4" ball valve					
				body	CW617N	EN12165	
				seat	PTFE		
				ball	CW617N	EN12165	
				end cap	CW617N	EN12165	
				stem	CW617N	EN12164	
				nut	CB4FF	EN10263-2	
				O-ring	FPM		
				handle	DD11	EN10111	
				handle coating	PVC		
				washer	PTFE		
LTL-E190			1" elbow		black steel	ASTM A53/A733	
21520			1" cross		black steel	ASTM A53/A733	
25503	Euroblock, 100002	1" check valve					
				body	brass CW617N	EN12165	
				end connection	brass CW617N	EN12165	
				disc	polyetherimide		
				seat	NBP		
				spring	stainless steel		
BBGB			1" X 1/4" reducing bushing		black steel	ASTM A53/A733	
26969_0350			1" x 3-1/2" nipple		black steel	ASTM A53/A733	
26969_0600			1" x 6" nipple		black steel	ASTM A53/A733	
26969_0150			1" close nipple		black steel	ASTM A53/A733	
LTL-CPN14112			1/4" x 1-1/2" nipple		black steel	ASTM A53/A733	
LTL-SCSP34			3/4" NPT plug		black steel	ASTM A53/A733	
LTL-SRB1418			1/4" x 1/8" reducing bushing		black steel	ASTM A53/A733	
LTL-ST1			1" TEE		black steel	ASTM A53/A733	
12177-4-M14			ftg, str, 1/4-18 to M14x1.5		steel, zink plated		

DIMENSIONS ARE IN: INCHES I J ARE IN: -	DO NOT SCALE PRINT SCALE 0.700	CWI DATA CLASSIFICATION Cummins Confidential	 Cummins Inc. ITEM NAME COOLING LOOP, 1", VERT RAW WATER
DRAWING TOLERANCES APPLY TO PRIMARY DIMENSIONS UNLESS OTHERWISE SPECIFIED X.1: ± .1 IN OR 4 mm X.2: ± .1 IN OR 2.5 mm X.3: ± .030 IN OR 0.75 mm X.4: ± .010 IN OR 0.25 mm ANGULAR TOLERANCE: ±	DWN - PBS CKD - APVD - DATE 12SEP16	FOR INTERPRETATION OF DIMENSIONING AND TOLERANCING, SEE ASME Y14.5-2009	
THIS DOCUMENT AND THE INFORMATION SHOWN THEREON IS CONFIDENTIAL AND PROPRIETARY AND SHALL NOT BE DISCLOSED TO OTHERS IN HARD COPY OR ELECTRONIC FORM, REPRODUCED BY ANY MEANS, OR USED FOR ANY PURPOSE WITHOUT WRITTEN CONSENT OF CUMMINS INC.		MUST CONFORM TO CES 10903	CAD SHEET 2 OF 2 ITEM NUMBER A042H730 REV 4

BILL OF MATERIAL			
ITEM	QTY	DESCRIPTION	PART NUMBER
1	1	SENDER, WATER TEMPERATURE; 1/8" NPT	8862
2	1	GAUGE, PRESSURE, 1/4" NPT; DPG1-2 1/2, 0-100 PSI, (WATTS)	8892
3	2	CONNECTOR, FEMALE; -4 NPT X M14 ORB, STEEL	12177-4-M14
4	2	VALVE, BALL, INPT; BRASS, LOCKABLE	21505
5	1	CROSS, INPT, STEEL; SCHEDULE 40 PIPE	21520
6	2	VALVE, 1" NPT CHECK; VALUE ADDED: CV100	25503
7	11	NIPPLE, PLAIN PIPE; -16 NPT X 1.50", BLACK	26969_0150
8	2	NIPPLE, PLAIN PIPE; -16 NPT X 3.50", BLACK	26969_0350
9	2	NIPPLE, PLAIN PIPE; -16 NPT X 6.00", BLACK	26969_0600
10	2	SEAL, METRIC BONDED; ADAPTALL 9500MM SERIES	26984-14
11	1	VALVE, SOLENOID, 1" NPT, 24VDC	A042B126
12	1	VALVE, BALL, 1/4" NPT FEMALE	A042D838
13	2	REGULATOR, 1" NPT, 400 PSI MAX, 25 TO 75 PSI OUT	A042D839
14	2	STRAINER, 1" NPT	A042D840
15	2	PLUG, THREADED, M14x1.5; McMASTER-CARR: 5481X25	A060R226
16	4	BUSHING, REDUCER, 1" X 1/4" NPT; -	BB6B
17	1	NIPPLE, 1/4" NPT x 1 1/2"; BLK STEEL	LTL-CPN14112
18	1	ELBOW, 90°, 1" NPT; BLK IRON	LTL-E190
19	2	PLUG, PIPE; 3/4 BIP COUNTERSUNK	LTL-SCSP34
20	1	REDUCER BUSHING, HEX; 1/4 x 1/8, BLK STEEL	LTL-SRB1418
21	4	TEE, BLK, 1"	LTL-ST1

REV	REL NO	REVISION	DWN	CKD	APVD	DATE
-	2016-376	INITIAL RELEASE	PBS			12SEP16
C	2018-360	DELETE: 12210-4; ADD: A060R226, 26984-14 & NOTE	HE392			03JUL18
4	2020-071	ADDED STRAINER SCREEN & O-RING NOTE	RE123	MS707	MS707	04FEB20

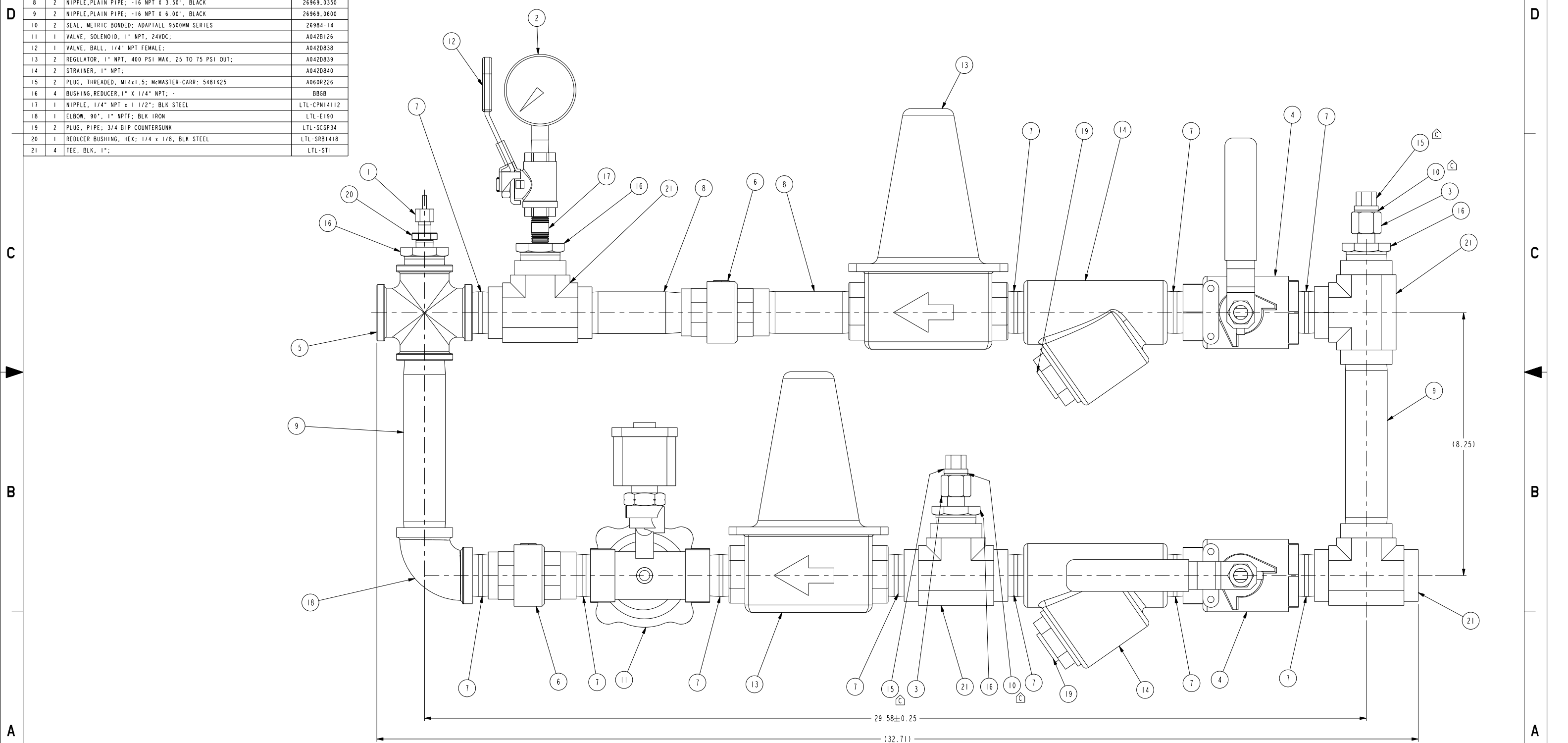

- NOTES:
- MATERIAL: SEE PARTS LIST
 - REMOVE ALL SHARP EDGES PRIOR TO COATING
 - LEAK TEST TO 60PSI AND PRESET REGULATORS TO 60PSI
 - FINISH: COAT PER CUMMINS SPEC ES044 RAL 3001
 - CAP ALL PORTS PRIOR TO SHIPPING
 - REPLACEMENT COMPONENTS FOR ITEM A042D840:
REPLACEMENT STRAINER SCREEN P/N: A063Z528
REPLACEMENT O-RING P/N: A063Z529

DIMENSIONS ARE IN: INCHES [] ARE IN: -	DO NOT SCALE PRINT SCALE 0.700	CWI DATA CLASSIFICATION Cummins Confidential		Cummins Inc.	
DRAWING TOLERANCES APPLY TO PRIMARY DIMENSIONS UNLESS OTHERWISE SPECIFIED X.1: ± 1/16 IN OR 0.7 mm X.2: ± 1/32 IN OR 0.25 mm X.3: ± 0.01 IN OR 0.25 mm ANGULAR TOLERANCES: ±	DWN: PBS CKD: - APVD: - DATE: 12SEP16	FOR INTERPRETATION OF DIMENSIONING AND TOLERANCING: SEE ASME Y14.5-2009		ITEM NAME COOLING LOOP, 1", 24V RAW WATER	CAD SHEET 1 OF 2
THIS DOCUMENT AND THE INFORMATION SHOWN THEREON IS CONFIDENTIAL AND PROPRIETARY AND SHALL NOT BE DISCLOSED TO OTHERS IN HARD COPY OR ELECTRONIC FORM, REPRODUCED BY ANY MEANS, OR USED FOR ANY PURPOSE WITHOUT WRITTEN CONSENT OF CUMMINS INC.			MUST CONFORM TO CES 10903	REV 4	

8	7	6	5	4	3	2	1
Assembly	Component	Manufacture/pn	Description	Sub-Component	Material	Specification	
A042H732	21505	RUB, S95F45	1" 24VDC, Raw Water 1" ball valve				
				body	CW617N	EN12165	
				seat	PTFE		
				ball	CW617N	EN12165	
				end cap	CW617N	EN12165	
				stem	CW617N	EN12164	
				nut	CB4FF	EN10263-2	
				O-ring	FPM		
				handle	DD11	EN10111	
				handle coating	PVC		
				washer	PTFE		
	A042B126	Asco, 8210G004-24V	1" NPT 24V solenoid valve				
				body	brass		
				seals and discs	NBR or PTFE		
				disc holder	PA		
				core tube	305 stainless steel		
				core and plugnut	430F stainless steel		
				springs	302 stainless steel		
				shading coil	copper		
	A042D839	Watts, N45BU-M1-1"	regulator				
				body	bronze		
				seat	thermoplastic		
				cage	thermoplastic		
				integral strainer	stainless steel		
				diaphragm	reinforced EPDM		
				valve disc	elastomer		
	A042D840	Watts, 77S-M1-1"	strainer				
				body	cast iron		
				retainer cap	cast iron	ASTM A-126 Class B	
				screen	304 stainless steel		
	8862	Datcon D2022-00	temperature sender	Body	brass		
	8892	Watts, DPG1-2	pressure gauge				
				case	ABS polymer		
				window	Kostil polymer		
				sensing element	copper alloy Bourdon tube		
				welding	tin alloy		
				connection	brass		
	A042D838	RUB, S95B45	1/4" ball valve				
				body	CW617N	EN12165	
				seat	PTFE		
				ball	CW617N	EN12165	
				end cap	CW617N	EN12165	
				stem	CW617N	EN12164	
				nut	CB4FF	EN10263-2	
				O-ring	FPM		
				handle	DD11	EN10111	
				handle coating	PVC		
				washer	PTFE		
	LTL-E190		1" elbow		black steel	ASTM A53/A733	
	21520		1" cross		black steel	ASTM A53/A733	
	25503	Euroblock, 100002	1" check valve				
				body	brass CW617N	EN12165	
				end connection	brass CW617N	EN12165	
				disc	polyetherimide		
				seat	NBP		
				spring	stainless steel		
	BBGB		1" X 1/4" reducing bushing		black steel	ASTM A53/A733	
	26969_0350		1" x 3-1/2" nipple		black steel	ASTM A53/A733	
	26969_0600		1" x 6" nipple		black steel	ASTM A53/A733	
	26969_0150		1" close nipple		black steel	ASTM A53/A733	
	LTL-CPN14112		1/4" x 1-1/2" nipple		black steel	ASTM A53/A733	
	LTL-SCSP34		3/4" NPT plug		black steel	ASTM A53/A733	
	LTL-SRB1418		1/4" x 1/8" reducing bushing		black steel	ASTM A53/A733	
	LTL-ST1		1" TEE		black steel	ASTM A53/A733	
	12177-4-M14		ftg, str, 1/4-18 to M14x1.5		steel, zinc plated		

DIMENSIONS ARE IN: INCHES 1/16 ARE IN: -	DO NOT SCALE PRINT SCALE 0.700	CWI DATA CLASSIFICATION Cummins Confidential	 Cummins Inc. ITEM NAME COOLING LOOP, 1", 24V RAW WATER
DRAWING TOLERANCES APPLY TO PRIMARY DIMENSIONS UNLESS OTHERWISE SPECIFIED X.1: ± 1/16 IN OR 1.5 mm X.2: ± 1/32 IN OR 0.7 mm X.3: ± 0.01 IN OR 0.25 mm X.4: ± 0.001 IN OR 0.025 mm ANGULAR TOLERANCE: ±	DWN - PBS CKD - APVD - DATE 12SEP16	FOR INTERPRETATION OF DIMENSIONING AND TOLERANCING, SEE ASME Y14.5-2009	
THIS DOCUMENT AND THE INFORMATION SHOWN THEREON IS CONFIDENTIAL AND PROPRIETARY AND SHALL NOT BE DISCLOSED TO OTHERS IN HARD COPY OR ELECTRONIC FORM, REPRODUCED BY ANY MEANS, OR USED FOR ANY PURPOSE WITHOUT WRITTEN CONSENT OF CUMMINS INC.		MUST CONFORM TO CES 10903	CAD SHEET 2 OF 2 ITEM NUMBER A042H732 REV 4

BILL OF MATERIAL			
ITEM	QTY	DESCRIPTION	PART NUMBER
1	1	ZINC MODULE, 2" NPT, 3 ANODES	15804
2	1	GROUND STRAP, 1/4" BRAID; 24" LONG, 1/4" & 1/2" TERMINALS	15843
3	3	ASSY, ADAPTER, 1.25" ORD x FNPT; W / O-RING	17247
4	1	ASSY, ADAPTER, 1.50" ORD x FNPT; W / O-RING	17255
5	4	CLAMP, PIPE, 1", PLASTIC	14925
6	4	CLAMP, WORM; .81 - 1.75	14990-20
7	2	ELBOW, MARINE GRADE; 1-1/4" NPT	15756-20
8	1	BUSHING, MARINE GRADE; 1-1/4" x 1"	15758-20-16
9	1	BUSHING, MARINE GRADE; 1-1/2" x 1-1/4"	15758-24-20
10	2	BUSHING, MARINE GRADE; 2" x 1-1/4"	15758-32-20
11	2	ADAPTER, NAVAL BRONZE, NPT X BARB; 1-1/4" NPT X 1-1/4" BARB	15766-20-20
12	2	ELBOW, NAVAL BRONZE, NPT X BARB; 1-1/4" NPT X 1-1/4" BARB	15767-20-20
13	1	NIPPLE, MARINE GRADE, 1" X 3"	15794
14	2	NIPPLE, MARINE GRADE, 1-1/4" X 1-5/8"	15797
15	2	BRACKET, LH COOLING LOOP; CFPI5E	26478
16	1	HOSE, SILICONE; 1.25IN IDx8.00IN LONG	A042F062
17	1	HOSE, SILICONE; 1.25IN IDx17.00IN LONG	A042F062

REV	REL NO	REVISION	DWN	CKD	APVD	DATE
-	2014-558	RELEASED TO PRODUCTION	PBS		-	07AUG14
A	2019-096	REPLACED A042F062 WAS 78125GL; ADDED NOTES	LQ629	MS707	MS707	04MAR19

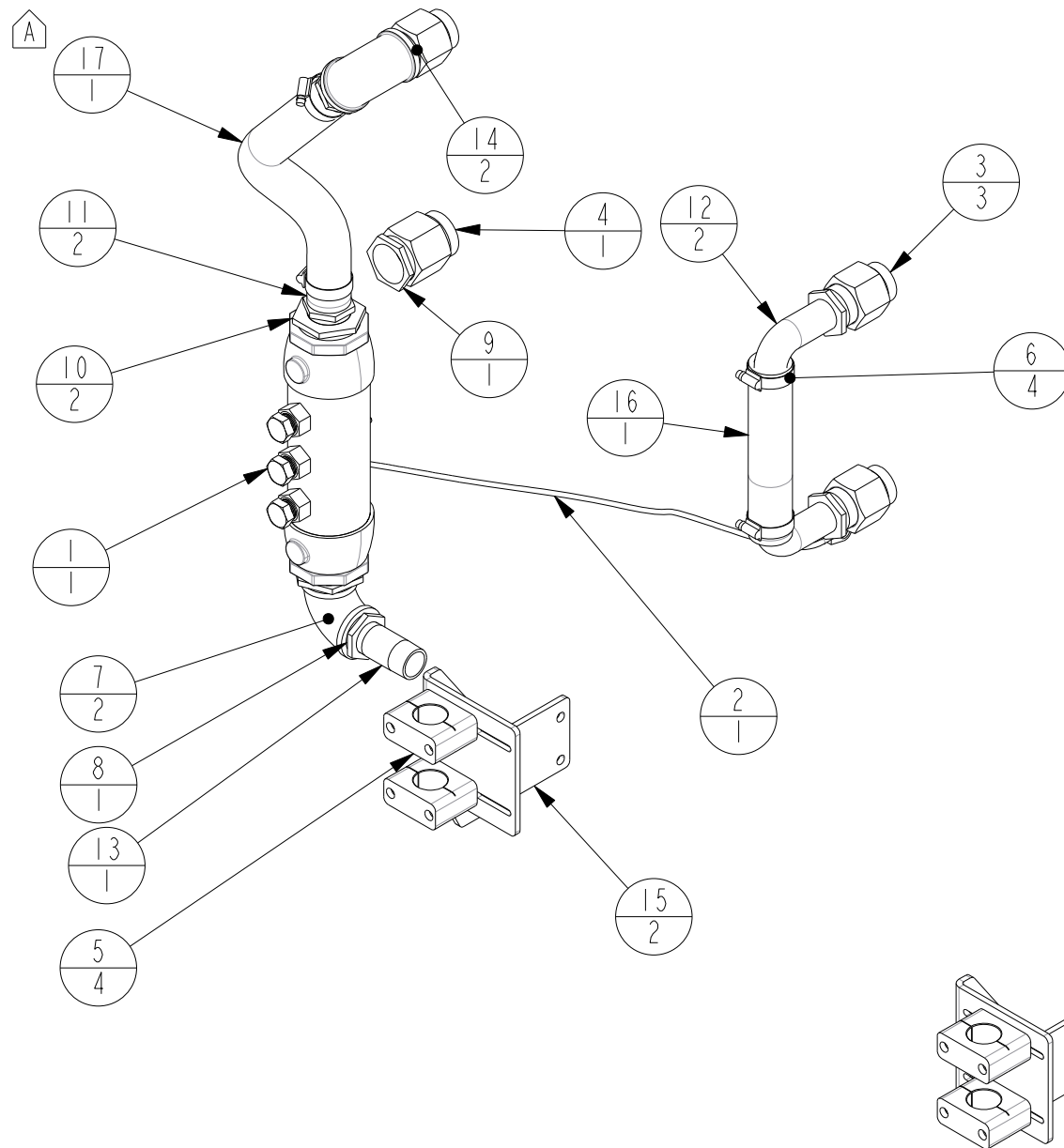

A
 NOTES:
 1. ZINC ANODE PART NUMBER 9750

DIMENSIONS ARE IN: INCHES [] ARE IN: INCHES	DO NOT SCALE PRINT	CMI DATA CLASSIFICATION Cummins Confidential		Cummins Inc.	
DRAWING TOLERANCES UNLESS OTHERWISE SPECIFIED	SCALE 0.150	DWN PBS		ITEM NAME	
X: ± 1 IN OR 4 mm X.X: ± .1 IN OR 0.7 mm X.XX: ± .030 IN OR 0.25 mm X.XXX: ± .010 IN OR 0.075 mm ANGULAR TOLERANCE: ± 1°		CKD -		MISC. PIPING, HX CFPI5E SEA WATER LOOP/RAW WATER	
THIS DOCUMENT (AND THE INFORMATION SHOWN THEREON) IS CONFIDENTIAL AND PROPRIETARY AND SHALL NOT BE DISCLOSED TO OTHERS IN HARD COPY OR ELECTRONIC FORM, REPRODUCED BY ANY MEANS, OR USED FOR ANY PURPOSE WITHOUT WRITTEN CONSENT OF CUMMINS INC.		DATE 07AUG2014	APVD -	MUST CONFORM TO CES 10903	ITEM NUMBER A042C201
			FOR INTERPRETATION OF DIMENSIONING AND TOLERANCING, SEE ASME Y14.5-2009	CAD SHEET 1 OF 1	

BILL OF MATERIAL			
ITEM	QTY	DESCRIPTION	PART NUMBER
1	1	SENDER, WATER TEMPERATURE; 1/8" NPT	8862
2	1	GAUGE, 0-100 PSI; 1/4" NPT STN STL	13113
3	1	REGULATOR/STRAINER, 1" NPT, SEA WATER COMPATIBLE;	14684
4	1	REGULATOR/STRAINER, 1" NPT, SEA WATER COMPATIBLE;	14684
5	4	TEE, MARINE GRADE; 1" NPT	15755-16
6	1	ELBOW, MARINE GRADE; 1" NPT	15756-16
7	4	BUSHING, MARINE GRADE; 1" x 1/4"	15758-16-4
8	1	BUSHING, MARINE GRADE; 1/4" x 1/8"	15758-4-2
9	1	VALVE, BALL, 1/4" NPT.; APOLLO 77-100 (MARINE)	15759-04
10	1	NIPPLE, NAVAL BRONZE, 1/4" X CLOSE;	15760
11	2	CHECK VALVE, MARINE GRADE, 1" NPT;	15768-16
12	6	NIPPLE, MARINE GRADE, 1" X 1-1/2";	15789
13	3	NIPPLE, MARINE GRADE, 1" X 6";	15792
14	3	NIPPLE, MARINE GRADE, 1" X 3";	15794
15	2	VALVE, BALL, 1/2" NPT; SEA WATER COMPATIBLE, LOCKABLE	21435
16	1	CROSS, I, NVL-BRNZ; SCHEDULE 40 PIPE	21437
17	2	SEAL, METRIC BONDED; ADAPTALL 9500MM SERIES	26984-14
18	2	ADAPTER, 1/4 NPT TO M14-1.5; SEA WATER COMPATIBLE	A042H751
19	2	PLUG, THREADED, M14x1.5; McMASTER-CARR: 5481X25	A060R226

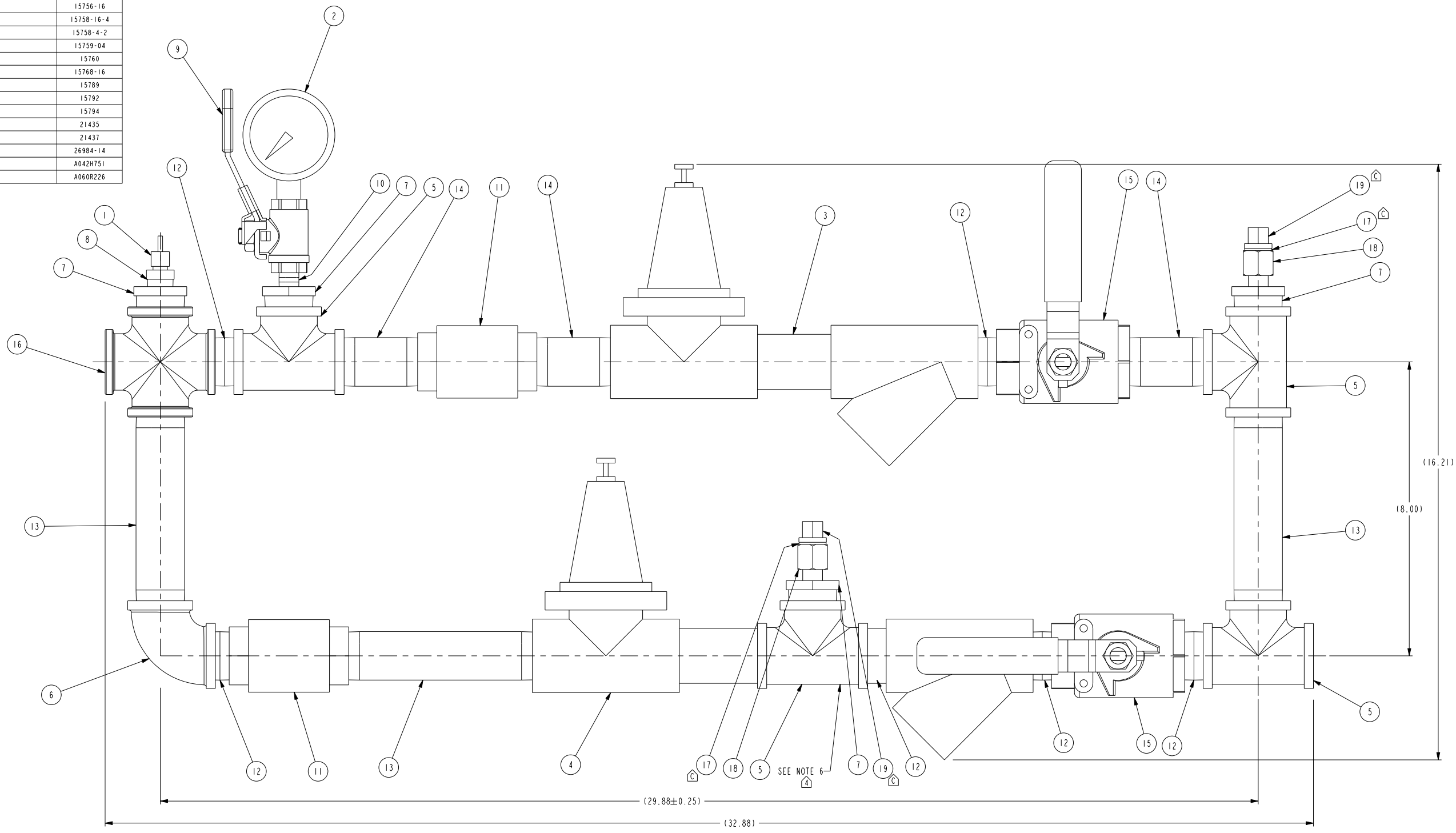

REV	REL NO	REVISION	DWN	CKD	APVD	DATE
-	2016-376	INITIAL RELEASE	PBS			12SEP16
C	2018-360	DELETE: 12210-4; ADD: A060R226, 26984-14, & NOTE	HE392			03JUL18
4	2020-071	UPDATED NOTES	RE123	MS707	MS707	04FEB20



- NOTES:
1. MATERIAL: SEE PARTS LIST
 2. REMOVE ALL SHARP EDGES PRIOR TO COATING
 3. LEAK TEST TO 60PSI AND PRESET REGULATORS TO 60PSI
 4. FINISH: COAT PER CUMMINS SPEC ES044 RAL 3001
 5. CAP ALL PORTS PRIOR TO SHIPPING
 6. ITEM 14684 IS RECEIVED AS AN UNASSEMBLED KIT. AT ASSEMBLY ADD ITEMS SHOWN
 7. REPLACEMENT COMPONENTS FOR ITEM 14684:
REPLACEMENT STRAINER SCREEN P/N: A0632532
REPLACEMENT O-RING P/N: A0632533

DIMENSIONS ARE IN: INCHES [] ARE IN: -	DO NOT SCALE PRINT SCALE 0.700	CWI DATA CLASSIFICATION Cummins Confidential		Cummins Inc.	
DRAWING TOLERANCES APPLY TO PRIMARY DIMENSIONS UNLESS OTHERWISE SPECIFIED X.1: ± 1/16 IN OR 0.7 mm X.2: ± 1/32 IN OR 0.35 mm X.3: ± 0.01 IN OR 0.25 mm X.4: ± 0.005 IN OR 0.125 mm ANGULAR TOLERANCE: ±	DWN: PBS CKD: - APVD: - DATE: 12SEP16	FOR INTERPRETATION OF DIMENSIONING AND TOLERANCING: SEE ASME Y14.5-2009		ITEM NAME COOLING LOOP, 1", VERT SEA WATER COMPATIBLE	CAD SHEET 1 OF 2
<small>THIS DOCUMENT AND THE INFORMATION SHOWN THEREON IS CONFIDENTIAL AND PROPRIETARY AND SHALL NOT BE DISCLOSED TO OTHERS IN HARD COPY OR ELECTRONIC FORM, REPRODUCED BY ANY MEANS, OR USED FOR ANY PURPOSE WITHOUT WRITTEN CONSENT OF CUMMINS INC.</small>			MUST CONFORM TO CES 10903	REV 4	

Assembly	Component	Manufacture/pn	Description	Sub-Component	Material	Specification
A042H733	21435	Apollo, 75-105-01	1" Vertical, Sea Water 1" ball valve	lever and grip	steel, zinc plated w/vinyl	
				stem packing	MPTFE	
				stem bearing	RPTFE	
				ball	chrome plated	ASTM B16
				seat	RPTFE	
				retainer		ASTM B16
				gland nut		ASTM B16
				stem		ASTM B16
				lever nut	steel, zinc plated	
				body seal	PTFE	
				body		ASTM B524-C84400
	8862	Datcon 02022-00	temperature sender	Body	brass	
	13113	Grainger, 4RY95	pressure gauge	case	stainless steel	
				socket	316 stainless steel	
				tube	316 stainless steel	
				lens	polycarbonate	
				ring	316 stainless steel	
	14684	Wilkins, 500YSBRHLRSW	1" regulator/strainer	body	cast bronze	ASTM B584
				access covers	cast bronze	ASTM B584
					brass	ASTM B16
				fasteners	300 series stainless steel	
				stem & plunger	cast bronze	ASTM B584
					brass	ASTM B16
				elastomers	Buna Nitrile	FDA approved
					EPDM	FDA approved
				cap gaskets	natural vulcanized fibre	
					Acetal (Delrin 500)	NSF Listed
				springs	oil tempered wire	ASTM A229
				strainer screen	300 series stainless steel	
				seat	300 series stainless steel	
	15755-16		1" tee		Copper Alloy	ASTM B62-09
	15756-16		1" elbow		Copper Alloy	ASTM B62-09
	15758-16-4		1" X 1/4" reducing bushing		Copper Alloy	ASTM B62-09
	15758-4-2		1/4" x 1/8" reducing bushing		Copper Alloy	ASTM B62-09
	15759-04	Apollo, 77-101-01	1/4" ball valve	lever and grip	steel, zinc plated w/vinyl	
				stem packing	MPTFE	
				stem bearing	RPTFE	
				ball	chrome plated	ASTM B16
				seat	RPTFE	
				retainer		ASTM B16
				gland nut		ASTM B16
				stem		ASTM B16
				lever nut	steel, zinc plated	
				body seal	PTFE	
				body		ASTM B524-C84400
	15760		1/4" close nipple		Copper Alloy	ASTM B62-09
	15768-16	Watts, series 600	1" check valve	body	bronze	
				guide bushing	stainless steel	
				spring	stainless steel	
				check	brass	
				seat	PTFE	
				O-ring	Nitrile	
				adapter	brass	
	15789		1" x 1-1/2" nipple		Copper Alloy	ASTM B62-09
	15792		1" x 6" nipple		Copper Alloy	ASTM B62-09
	15794		1" x 4" nipple		Copper Alloy	ASTM B62-09
	21437		1" cross		Copper Alloy	ASTM B62-09
	A042H751		adapter 1/4 NPT to M14-1.5		Copper Alloy	ASTM B62-09

DIMENSIONS ARE IN: INCHES [] ARE IN: -	DO NOT SCALE PRINT SCALE 0.700	CWI DATA CLASSIFICATION Cummins Confidential	 Cummins Inc. ITEM NAME COOLING LOOP, 1", VERT SEA WATER COMPATIBLE
DRAWING TOLERANCES APPLY TO PRIMARY DIMENSIONS UNLESS OTHERWISE SPECIFIED X.1: ± 1/16 IN OR 1.6 mm X.2: ± 1/32 IN OR 0.7 mm X.3: ± 0.001 IN OR 0.025 mm X.4: ± 0.0005 IN OR 0.0125 mm ANGULAR TOLERANCE: ±	 DWN - PBS CKD - APVD - DATE 12SEP16	FOR INTERPRETATION OF DIMENSIONING AND TOLERANCING, SEE ASME Y14.5-2009 MUST CONFORM TO CES 10903	
THIS DOCUMENT AND THE INFORMATION SHOWN THEREON IS CONFIDENTIAL AND PROPRIETARY AND SHALL NOT BE DISCLOSED TO OTHERS IN HARD COPY OR ELECTRONIC FORM, REPRODUCED BY ANY MEANS, OR USED FOR ANY PURPOSE WITHOUT WRITTEN CONSENT OF CUMMINS INC.		CAD SHEET 2 OF 2	ITEM NUMBER A042H733
		REV 4	

BILL OF MATERIAL			
ITEM	QTY	DESCRIPTION	PART NUMBER
1	1	SENDER, WATER TEMPERATURE; 1/8" NPT	8862
2	1	GAUGE, 0-100 PSI; 1/4" NPT STN STL	13113
3	1	VALVE, SOLENOID, 1" NPT, 24VDC; SEA WATER COMPATIBLE	14681
4	1	REGULATOR/STRAINER, 1" NPT, SEA WATER COMPATIBLE;	14684
5	1	REGULATOR/STRAINER, 1" NPT, SEA WATER COMPATIBLE;	14684
6	4	TEE, MARINE GRADE; 1" NPT	15755-16
7	1	ELBOW, MARINE GRADE; 1" NPT	15756-16
8	1	BUSHING, MARINE GRADE; 1" x 1/8"	15758-16-2
9	3	BUSHING, MARINE GRADE; 1" x 1/4"	15758-16-4
10	1	VALVE, BALL, 1/4" NPT.; APOLLO 77-100 (MARINE)	15759-04
11	1	NIPPLE, NAVAL BRONZE, 1/4" X CLOSE;	15760
12	2	CHECK VALVE, MARINE GRADE, 1" NPT;	15768-16
13	6	NIPPLE, MARINE GRADE, 1" X 1-1/2";	15789
14	2	NIPPLE, MARINE GRADE, 1" X 6";	15792
15	3	NIPPLE, MARINE GRADE, 1" X 3";	15794
16	2	VALVE, BALL, 1/2" NPT; SEA WATER COMPATIBLE, LOCKABLE	21435
17	1	CROSS, 1.1NVL-BRNZ; SCHEDULE 40 PIPE	21437
18	2	SEAL, METRIC BONDED; ADAPTALL 9500MM SERIES	26984-14
19	1	NIPPLE, 1" PIPE, 3.40" L; SEA WATER COMPATIBLE	A042H250
20	1	NIPPLE, 1" PIPE, 3.58" L; SEA WATER COMPATIBLE	A042H251
21	2	ADAPTER, 1/4 NPT TO M14-1.5; SEA WATER COMPATIBLE	A042H751
22	2	PLUG, THREADED, M14x1.5; McMASTER-CARR: 5481N25	A060R226

REV	REL NO	REVISION	DWN	CKD	APVD	DATE
-	2016-376	INITIAL RELEASE	PBS			12SEP16
C	2018-360	DELETE: 12210-4; ADD: A060R226, 26984-14 & NOTE	HE392			03JUL18
4	2020-071	UPDATED NOTES & TABLE ON SHEET 2	RE123	MS707	MS707	04FEB20

D
C
B
A

D
C
B
A

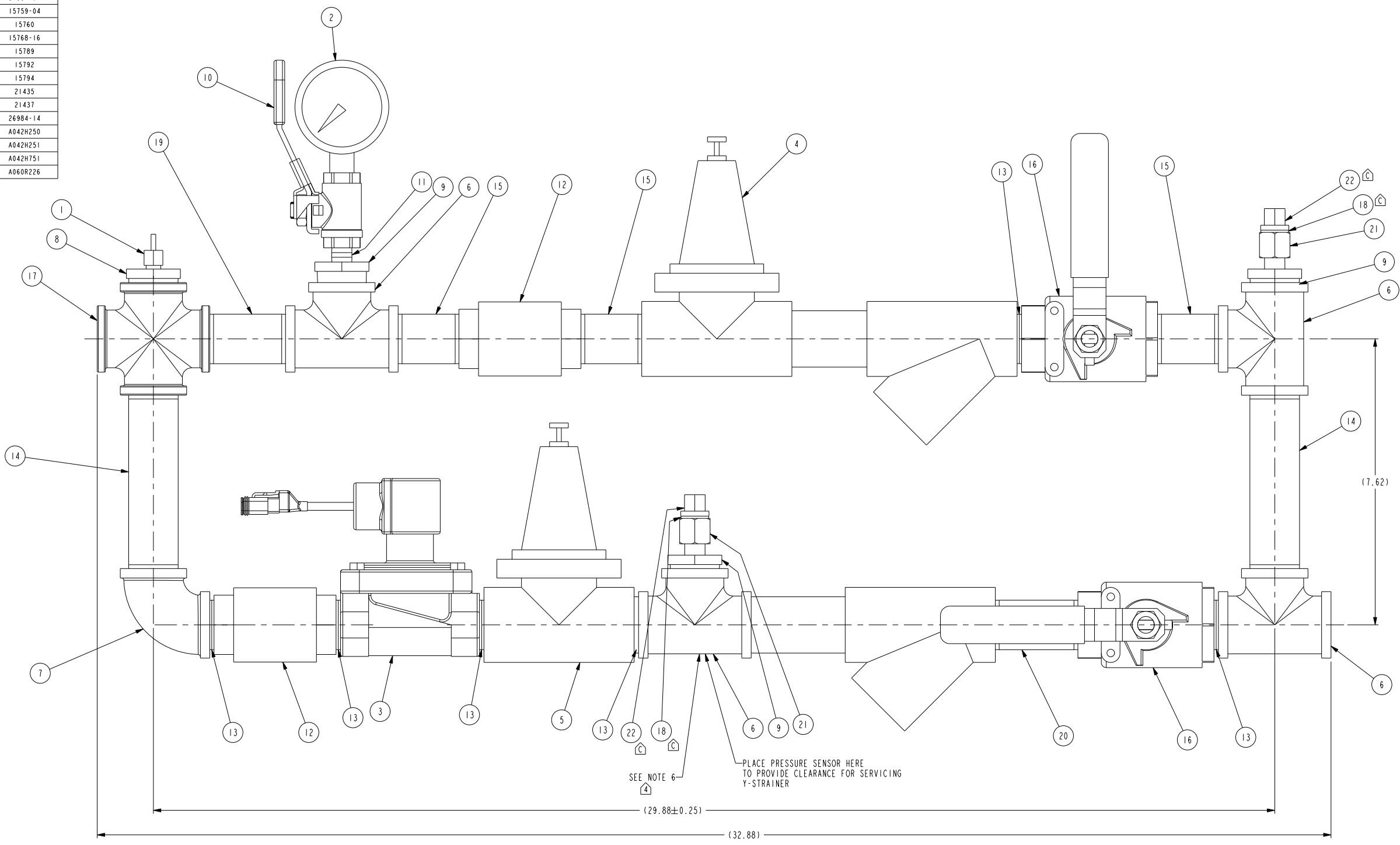



- NOTES:
1. MATERIAL: SEE PARTS LIST
 2. REMOVE ALL SHARP EDGES PRIOR TO COATING
 3. LEAK TEST TO 60PSI AND PRESET REGULATORS TO 60PSI
 4. FINISH: COAT PER CUMMINS SPEC ESO44 RAL 3001
 5. CAP ALL PORTS PRIOR TO SHIPPING
 6. ITEM 14684 COMES AS AN UNASSEMBLED KIT. AT ASSEMBLY ADD ITEMS SHOWN
 7. REPLACEMENT COMPONENTS FOR ITEM 14684:
REPLACEMENT STRAINER SCREEN P/N: A063Z532
REPLACEMENT O-RING P/N: A063Z533

DIMENSIONS ARE IN: INCHES [] ARE IN: -	DO NOT SCALE PRINT SCALE 0.700	CWI DATA CLASSIFICATION Cummins Confidential		Cummins Inc.			
<small>DRAWING TOLERANCES APPLY TO PRIMARY DIMENSIONS UNLESS OTHERWISE SPECIFIED</small> X.1: ± 1/16 IN OR 1.6 mm X.2: ± 1/32 IN OR 0.8 mm X.3: ± 0.01 IN OR 0.25 mm X.4: ± 0.005 IN OR 0.125 mm ANGULAR TOLERANCE: ±	DWN: PBS CKD: - APVD: - DATE: 12SEP16	FOR INTERPRETATION OF DIMENSIONING AND TOLERANCING, SEE ASME Y14.5-2009		MUST CONFORM TO CES 10903	ITEM NAME COOLING LOOP, 1", 24V SEA WATER COMPATIBLE	CAD SHEET 1 OF 2	ITEM NUMBER A042H735

8 7 6 5 4 3 2 1

8	7	6	5	4	3	2	1
Assembly	Component	Manufacture/pn	Description	Sub-Component	Material	Specification	
A042H735			1" 24VDC, Sea Water				
	14681	GC Valves, S211GF16J7FG9	1" NPT 24V solenoid valve	valve body/bonnet	316 stainless steel	ASTM A351 CF8M	
				plunger tube - tub head	430FR	ASTM A838 alloy 2	
				tube head shading ring	commercial grade silver	ASTM B742-90	
				plunger tube	304 stainless steel	ASTM A269	
				valve plunger	430FR	ASTM A838 alloy 2	
				plunger spring	302 stainless steel	ASTM 313-08	
				diaphragm spring	302 stainless steel	ASTM 313-08	
				diaphragm dish plate	304 stainless steel	ASTM A276-13	
				pilot orifice insert	304 stainless steel	ASTM A240	
				diaphragm hardware - M6 screw	18-8 stainless steel	ASTM F837M	
				diaphragm hardware - lock washer	18-8 stainless steel	ASTM B18.21.1	
				diaphragm hardware - nut	18-8 stainless steel	ASTM F593-85	
	21435	Apollo, 75-105-01	1" ball valve	lever and grip	steel, zinc plated w/vinyl		
				stem packing	MPTFE		
				stem bearing	RPTFE		
				ball	chrome plated	ASTM B16	
				seat	RPTFE		
				retainer		ASTM B16	
				gland nut		ASTM B16	
				stem		ASTM B16	
				lever nut	steel, zinc plated		
				body seal	PTFE		
				body		ASTM B524-C84400	
	8862	Datcon 02022-00	temperature sender	Body	brass		
	13113	Grainger, 4RY95	pressure gauge	case	stainless steel		
				socket	316 stainless steel		
				tube	316 stainless steel		
				lens	polycarbonate		
				ring	316 stainless steel		
	14684	Wilkins, 500YSBRHLRSW	1" regulator/strainer	body	cast bronze	ASTM B584	
				access covers	cast bronze	ASTM B584	
					brass	ASTM B16	
				fasteners	300 series stainless steel		
				stem & plunger	cast bronze	ASTM B584	
					brass	ASTM B16	
				elastomers	Buna Nitrile	FDA approved	
					EPDM	FDA approved	
				cap gaskets	natural vulcanized fibre		
					Acetal (Delrin 500)	NSF Listed	
				springs	oil tempered wire	ASTM A229	
				strainer screen	300 series stainless steel		
				seat	300 series stainless steel		
	15755-16		1" tee		Copper Alloy	ASTM B62-09	
	15756-16		1" elbow		Copper Alloy	ASTM B62-09	
	15758-16-4		1" X 1/4" reducing bushing		Copper Alloy	ASTM B62-09	
	15758-16-2		1" x 1/8" reducing bushing		Copper Alloy	ASTM B62-09	
	15759-04	Apollo, 77-101-01	1/4" ball valve	lever and grip	steel, zinc plated w/vinyl		
				stem packing	MPTFE		
				stem bearing	RPTFE		
				ball	chrome plated	ASTM B16	
				seat	RPTFE		
				retainer		ASTM B16	
				gland nut		ASTM B16	
				stem		ASTM B16	
				lever nut	steel, zinc plated		
				body seal	PTFE		
				body		ASTM B524-C84400	
	15760		1/4" close nipple		Copper Alloy	ASTM B62-09	
	15768-16	Watts, series 600	1" check valve	body	bronze		
				guide bushing	stainless steel		
				spring	stainless steel		
				check	brass		
				seat	PTFE		
				O-ring	Nitrile		
				adapter	brass		
	15789		1" x 1-1/2" nipple		Copper Alloy	ASTM B62-09	
	15792		1" x 6" nipple		Copper Alloy	ASTM B62-09	
	15794		1" x 4" nipple		Copper Alloy	ASTM B62-09	
	A042H250		1" x 3.4" nipple		Copper Alloy	ASTM B62-09	
	A042H251		1" x 3.58" nipple		Copper Alloy	ASTM B62-09	
	21437		1" cross		Copper Alloy	ASTM B62-09	
	A072H751		adapter 1/4 NPT to M14-1.5		Copper Alloy	ASTM B62-09	

DIMENSIONS ARE IN: INCHES [] ARE IN: -	DO NOT SCALE PRINT SCALE 0.700	CWI DATA CLASSIFICATION Cummins Confidential	 Cummins Inc. ITEM NAME COOLING LOOP, 1", 24V SEA WATER COMPATIBLE
DRAWING TOLERANCES APPLY TO PRIMARY DIMENSIONS UNLESS OTHERWISE SPECIFIED X.1: ± 1/16 IN OR 1.6 mm X.2: ± 1/32 IN OR 0.8 mm X.3: ± 0.01 IN OR 0.25 mm X.4: ± 0.005 IN OR 0.125 mm ANGULAR TOLERANCE: ±	 FOR INTERPRETATION OF DIMENSIONING AND TOLERANCING, SEE ASME Y14.5-2009	DWN - PBS CKD - APVD - DATE 12SEP16	
THIS DOCUMENT AND THE INFORMATION SHOWN THEREON IS CONFIDENTIAL AND PROPRIETARY AND SHALL NOT BE DISCLOSED TO OTHERS IN HARD COPY OR ELECTRONIC FORM, REPRODUCED BY ANY MEANS, OR USED FOR ANY PURPOSE WITHOUT WRITTEN CONSENT OF CUMMINS INC.		MUST CONFORM TO CES 10903	CAD SHEET 2 OF 2 ITEM NUMBER A042H735 REV 4

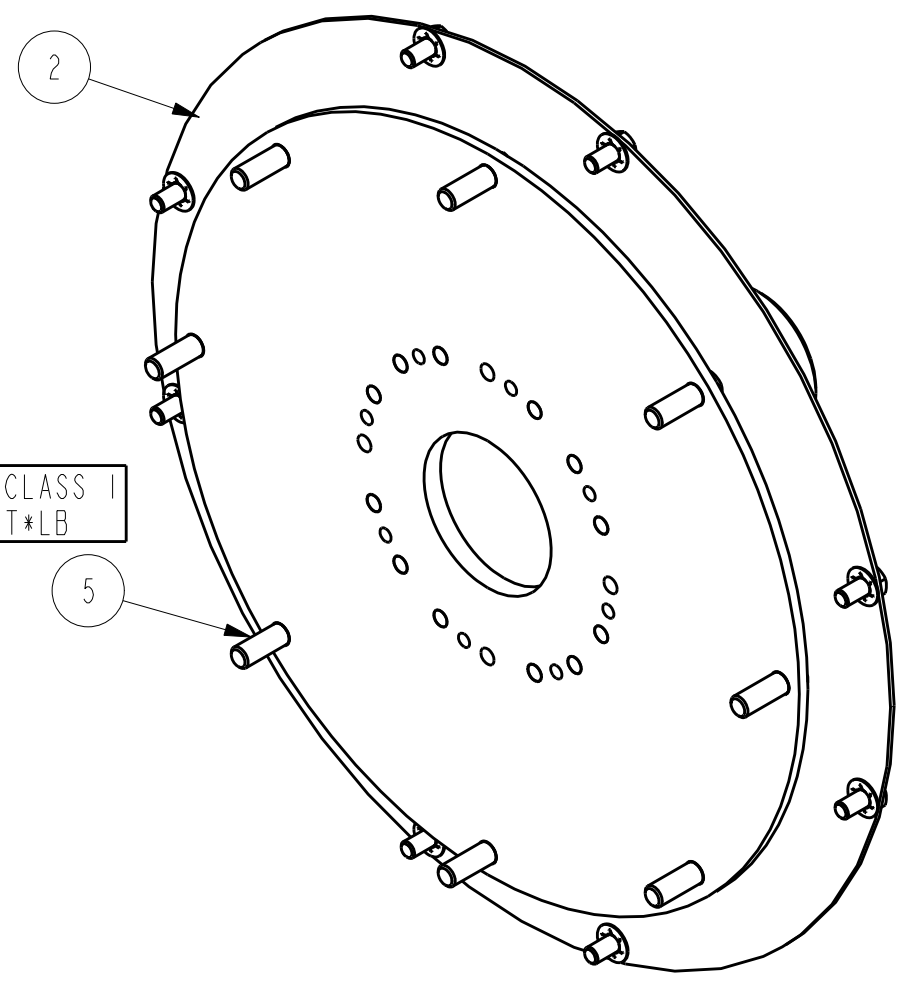
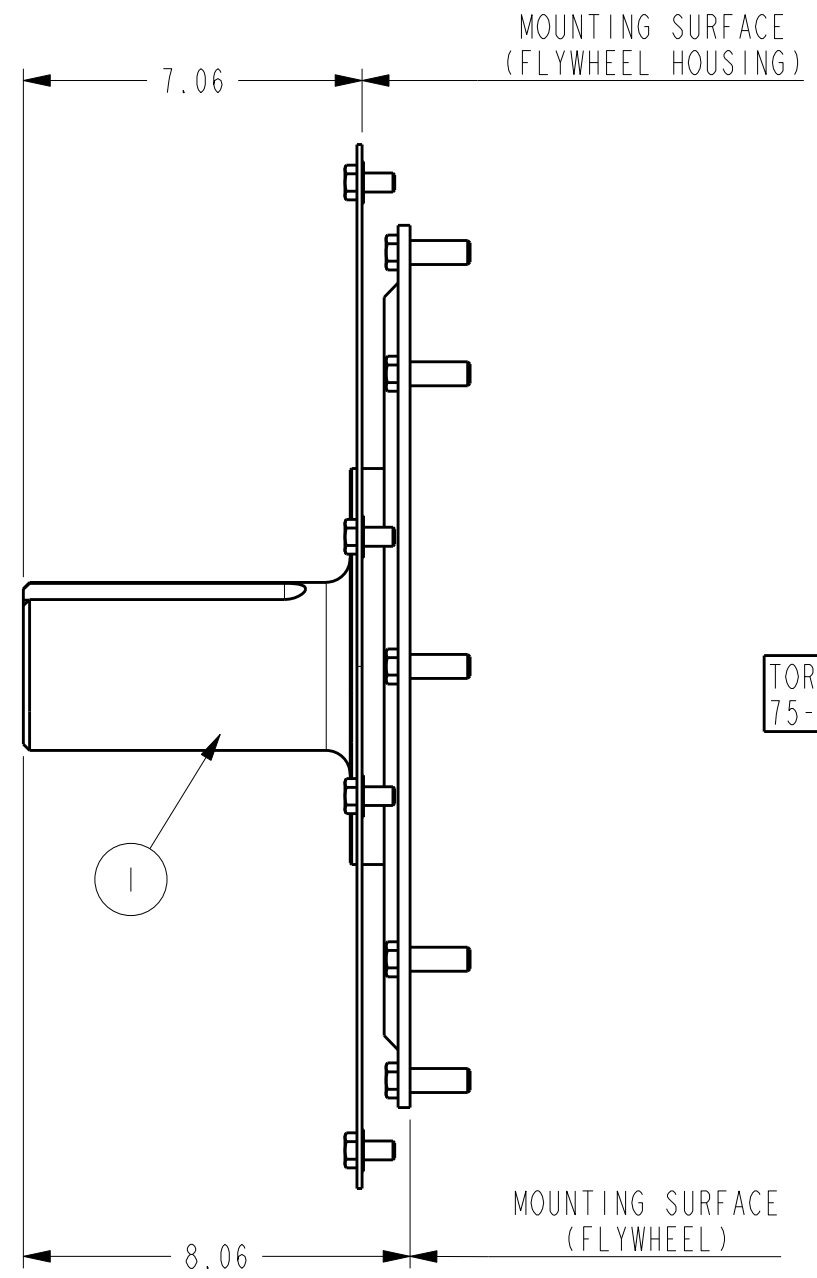
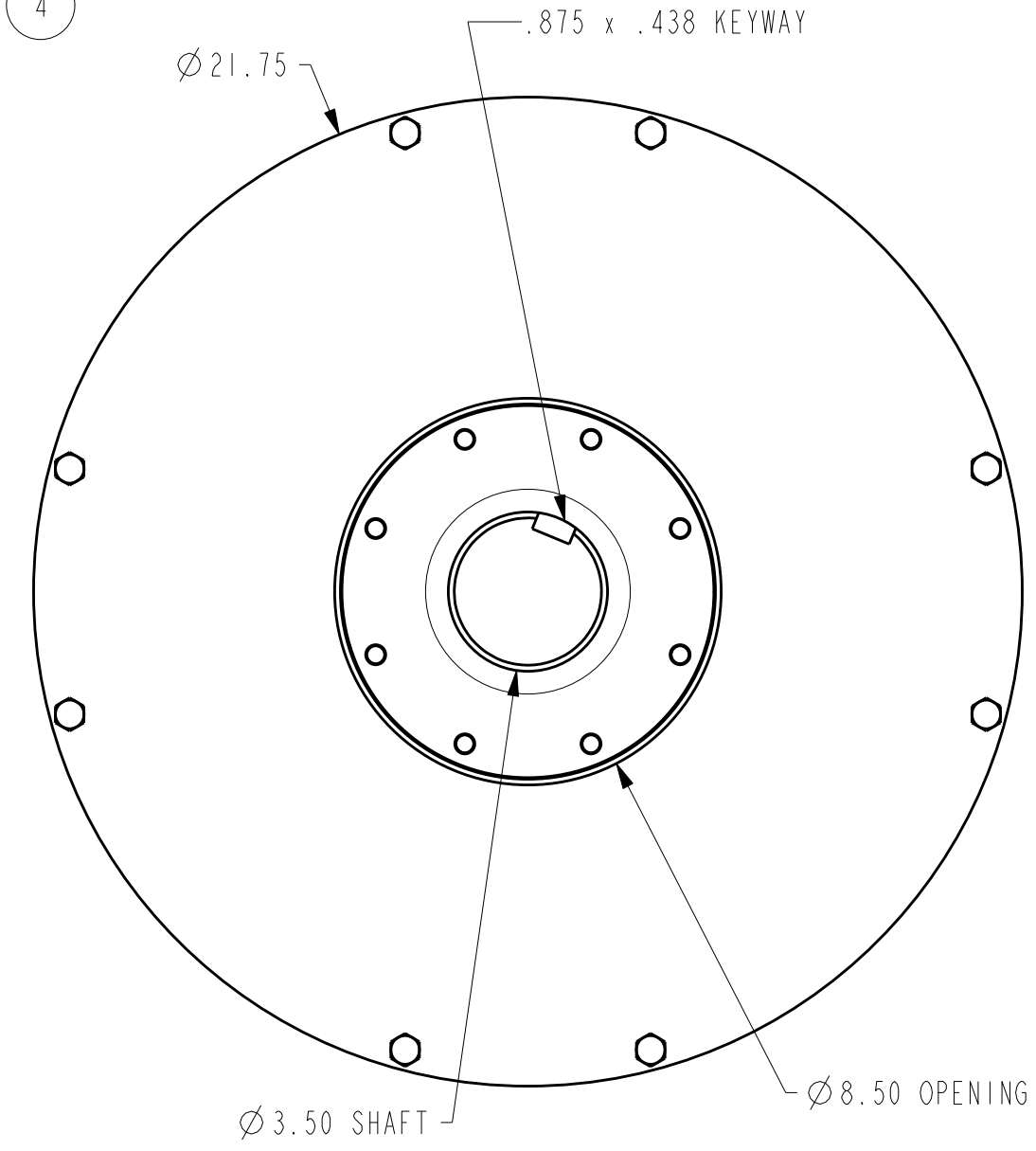
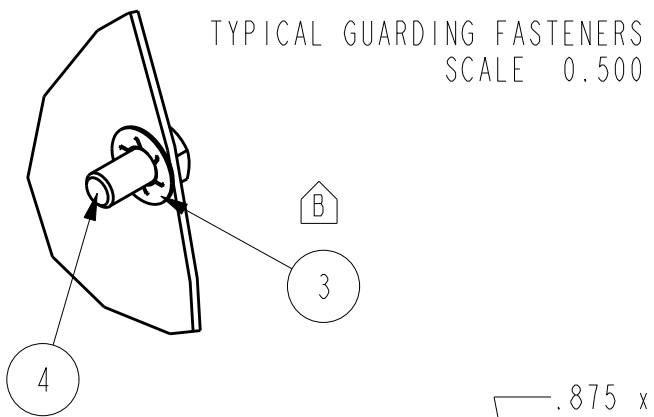

TORQUE CLASS 1
75-80 FT*LB

BILL OF MATERIAL

ITEM	QTY	DESCRIPTION	PART NUMBER
1	1	ASSEMBLY, SAE 1, 3.50" DIA STUB SHAFT, CFP15E	14976
2	1	GUARD, FLYWHEEL, SAE#1, CFP15E	12591
3	8	RETAINING WASHER, PUSHNUT, 7/16" BOLT	16662-07
4	8	SCREW, CAP, HEX HEAD, 7/16-14 UNC	HHCS_0437_0075
5	8	SCREW, CAP, HEX HEAD, 1/2-13 UNC X 1.50"	HHCS_0500_0150

NOTES:
A 1. MASS: 60.2 LBS, INERTIA: 1362.69 LB.IN²

This document contains confidential and trade secret information, is the property of Cummins Fire Power LLC and is given to the receiver in confidence. The receiver, by receiving and retaining of the document accepts the document in confidence and agrees that, except as authorized in writing by Cummins NPower, it will (1) not use the document or any copy thereof or the confidential or trade secret information therein, (2) not copy the document, (3) not disclose to others either the document or the confidential or trade secret information therein, and (4) upon completion of the need to retain the document, or upon demand, return the document, all copies thereof, and all material copied therefrom. COPYRIGHT Cummins Fire Power LLC



CUMMINS FIRE POWER LLC
CORPORATE OFFICE
1600 BUERKLE ROAD
WHITE BEAR LAKE, MN
WWW.CUMMINSFIREPOWER.COM

CUSTOM DESIGN
AND UPFIT CENTER
875 LAWRENCE DRIVE
DEPERE, WISCONSIN

ASSEMBLY, STUB SHAFT WITH GUARD
FIREPUMP, CFP15E

REV	ECO	DESCRIPTION OF REVISION	REV BY	DATE
B	2010-098	ADDED RETAINING WASHERS	DAN	04-MAR-10
A	2009-620	UPDATED STUB SHAFT. ADDED MASS & INERTIA DATA	S DUBICK	12/28/09

UNLESS OTHERWISE SPECIFIED ALL DIMENSION TOLERANCES ARE	
ANGULAR DIMENSIONS ± 1°	IMPERIAL UNITS
THIRD ANGLE PROJECTION	MACHINE TOLERANCES .XX ± 0.010 .X ± 0.005 FOM TOLERANCES .XX ± 0.020 .X ± 0.015 FAB TOLERANCES .XX ± 0.030 .X ± 0.020
	MACHINE TOLERANCES .X ± 0.2 FOM TOLERANCES .X ± 0.4 FAB TOLERANCES .X ± 0.5 .X ± 0.8

DWG UNITS: IN/LB/S	DRAWN BY: S DUBICK PRO-ENGINEER	DATE: 17JAN2008 INIT ECO:
SCALE: 0.250	SHEET 1 OF 1	DRAWING NO: 12590
EST WEIGHT: 71.028		

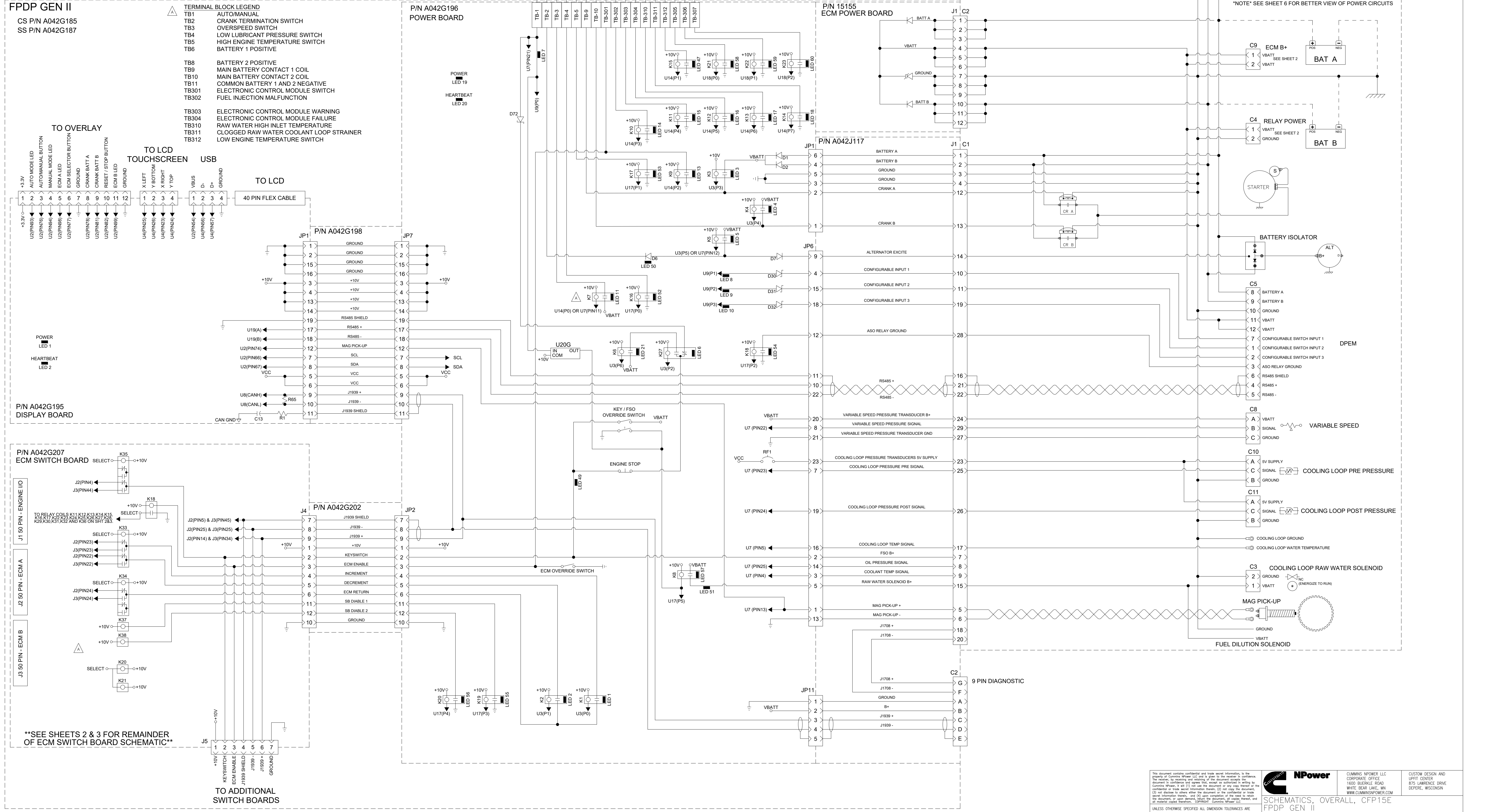

****SEE SHEETS 2 & 3 FOR REMAINDER OF ECM SWITCH BOARD SCHEMATIC****

<small>This document contains confidential and trade secret information. It is the property of Cummins NPower LLC and is loaned to the receiver in confidence. The receiver, by receiving and retaining or the document accepts the responsibility of maintaining the confidentiality of the document. It is not to be disclosed, copied, or otherwise made available to any third party without the express written consent of Cummins NPower LLC. If you are not an intended recipient, you should not disseminate, distribute, or copy this document. If you have received this document in error, please notify the sender immediately by e-mail at custserv@cummins.com. This document is for informational purposes only. Cummins NPower LLC is not responsible for any errors or omissions in this document. ©2016 Cummins NPower LLC.</small>		Cummins NPower CUMMINS NPOWER LLC CORPORATE OFFICE 1600 BURNLEY ROAD WHITE BEAR LAKE, MN WWW.CUMMINSNPOWER.COM	CUSTOM DESIGN AND UPTI CENTER 875 LAWRENCE DRIVE DEPERE, WISCONSIN
UNLESS OTHERWISE SPECIFIED ALL DIMENSION TOLERANCES ARE: ANGULAR DIMENSIONS ± 1° THIRD ANGLE PROJECTION		DWG UNITS: INCH/LB/S SCALE: AUTO CAD EST WEIGHT:	DATE: 22 NOV 2016 INIT ECO: 2016-694 SHEET 1 OF 6 DRAWING NO: A042J125
A 2019-037 REV ECO	ADDED TB LEGEND, CORRECT SENSOR DISCONNECT CIRCURY CORRECTED USE SWITCH TO B+	JF BY DATE	24/JAN/2019

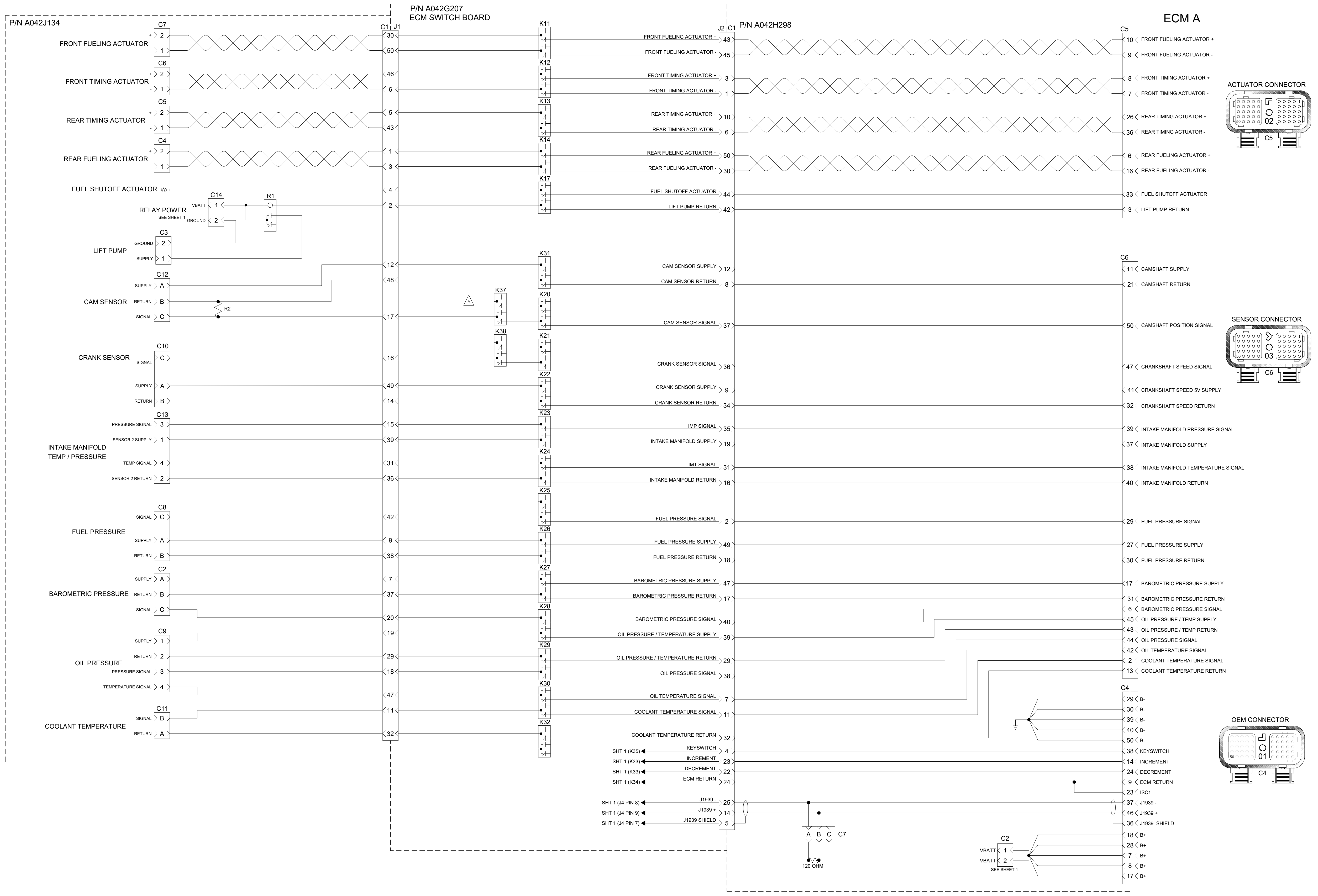

This document contains confidential and trade secret information. It is the property of Cummins NPower LLC and is loaned to the receiver in confidence. The receiver, by receiving and retaining this document, accepts the responsibility to maintain and protect this information. It is not to be disclosed, copied, or otherwise made available to any third party without the prior written consent of Cummins NPower LLC. If you are not an authorized recipient, you should not use this document. If you are an authorized recipient, you should not disclose this information to any third party without the prior written consent of Cummins NPower LLC. If you are a third party, you should not use this document. If you are a third party, you should not disclose this information to any third party without the prior written consent of Cummins NPower LLC.

UNLESS OTHERWISE SPECIFIED ALL DIMENSION TOLERANCES ARE:

ANGULAR DIMENSIONS ± 1°	IMPERIAL UNITS	METRIC UNITS
THIRD ANGLE PROJECTION	INCH/LB/S	MM/M
	± 0.005	± 0.15
	± 0.010	± 0.30
	± 0.020	± 0.60
	± 0.050	± 1.50
	± 0.100	± 3.00

SCHEMATICS, OVERALL, CFP15E
FPDP GEN II

DWG UNITS: INCH/LB/S
 SCALE: 1:1
 EST WEIGHT: SHEET 2 OF 6

DRAWN BY: KAK
AUTO CAD
 DATE: 22 NOV 2016
 INIT ECO: 2016-694
 DRAWING NO: A042J125

CUMMINS NPower LLC
 CORPORATE OFFICE
 1600 BLUEVALE ROAD
 WHITE BEAR LAKE, MN
 WWW.CUMMINSPOWER.COM

CUSTOM DESIGN AND
 UPGRADE CENTER
 875 LAWRENCE DRIVE
 DEPERE, WISCONSIN

REV	DATE	DESCRIPTION OF REVISION	BY
A	2019-037	SEE SHEET 1 FOR DETAILS	JF
REV	ECO	DESCRIPTION OF REVISION	DATE

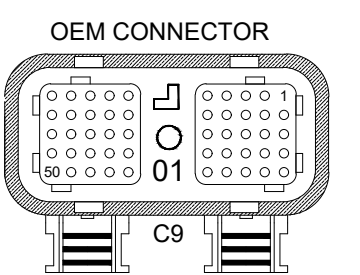
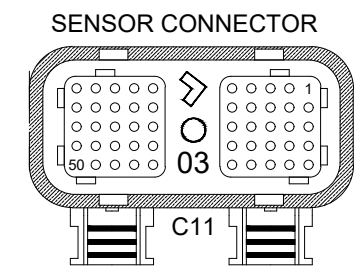
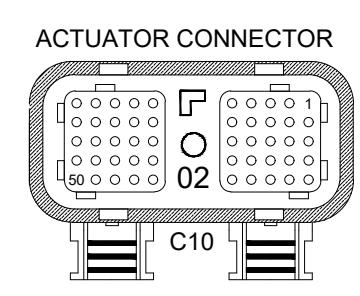
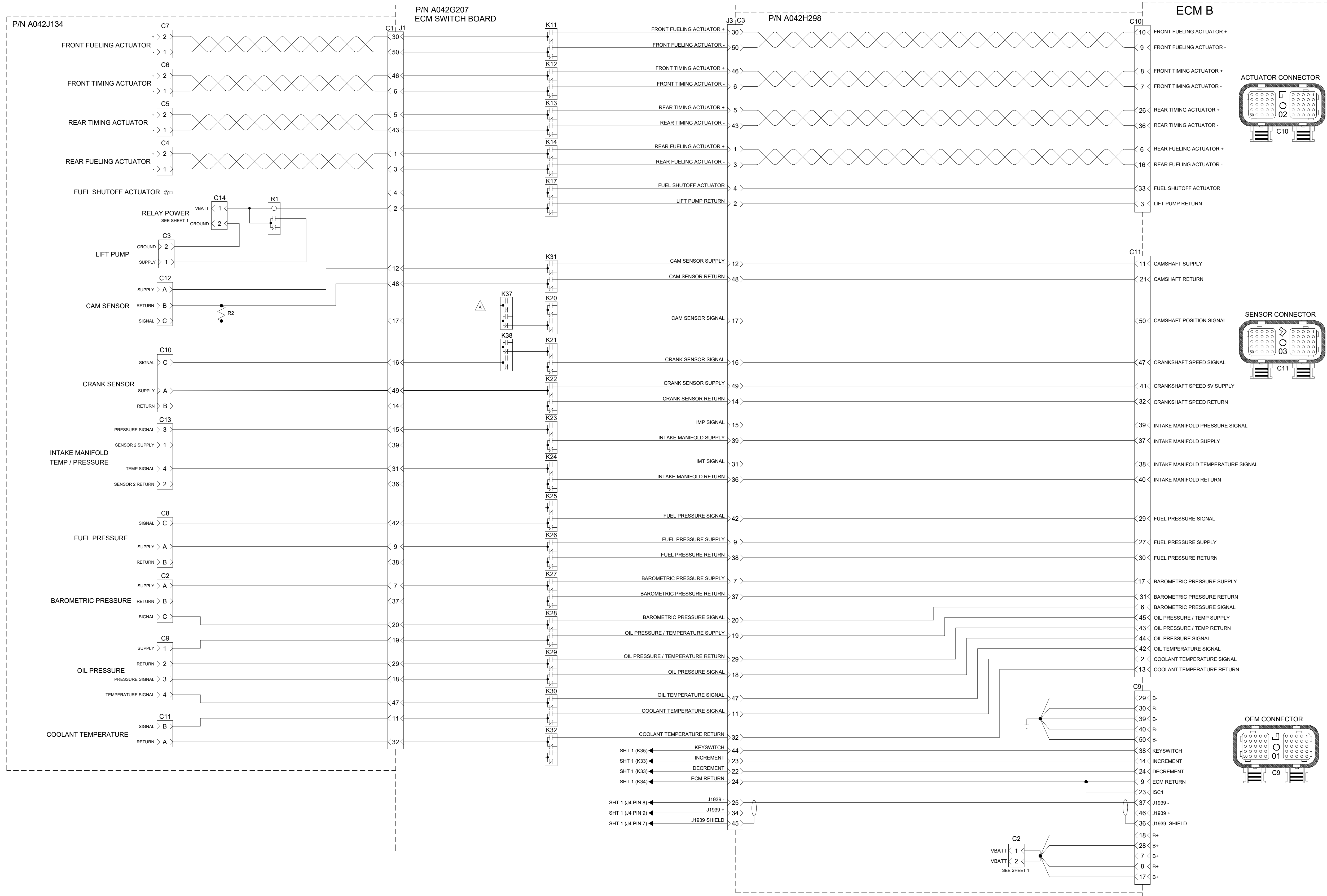

This document contains confidential and trade secret information. It is the property of Cummins NPower LLC and is loaned to the recipient in confidence. The recipient, by receiving and retaining, or the document accepts the document in confidence and agrees not to disclose, disseminate, or otherwise use the information herein, and to use the information herein only for the purposes intended. If you are not the intended recipient, you should not disseminate, distribute, or otherwise use the information herein. If you have received this document in error, please notify the sender immediately. © 2016 Cummins NPower LLC.

Cummins NPower
 CUMMINS NPOWER LLC
 CORPORATE OFFICE
 1600 BLUEVALE ROAD
 WHITE BEAR LAKE, MN
 WWW.CUMMINSNPOWER.COM

CUSTOM DESIGN AND
 UPTIT CENTER
 875 LAWRENCE DRIVE
 DEPERE, WISCONSIN

SCHEMATICS, OVERALL, CFP15E
 FPDP_GEN II

UNLESS OTHERWISE SPECIFIED ALL DIMENSION TOLERANCES ARE:
 ANGULAR DIMENSIONS ± 1°
 THIRD ANGLE PROJECTION

IMPERIAL UNITS
 INCH/LB/S

METRIC UNITS
 MILLIMETER
 METER/KG/S

DWG UNITS: INCH/LB/S
 SCALE: EST WEIGHT:

DRAWN BY: KAK
AUTO CAD

DATE: 22 NOV 2016
 INIT ECO: 2016-694

A	2019-037	SEE SHEET 1 FOR DETAILS	JF	24/JAN/2019
REV	ECO	DESCRIPTION OF REVISION	BY	DATE

NO ASO OPTION WITH UP TO 3 SWITCHED INPUTS

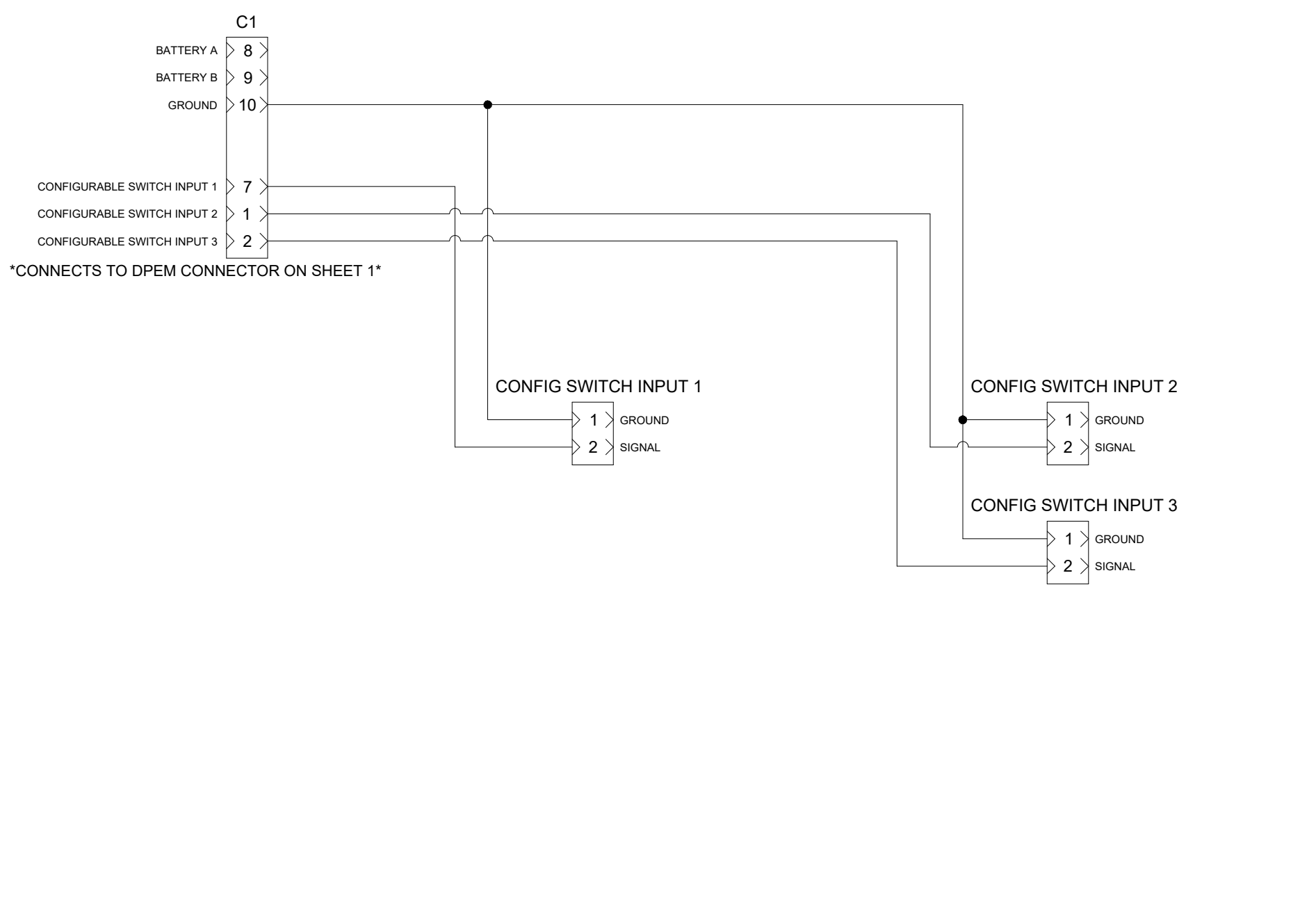

DPEM OPTION WITH NO ASO

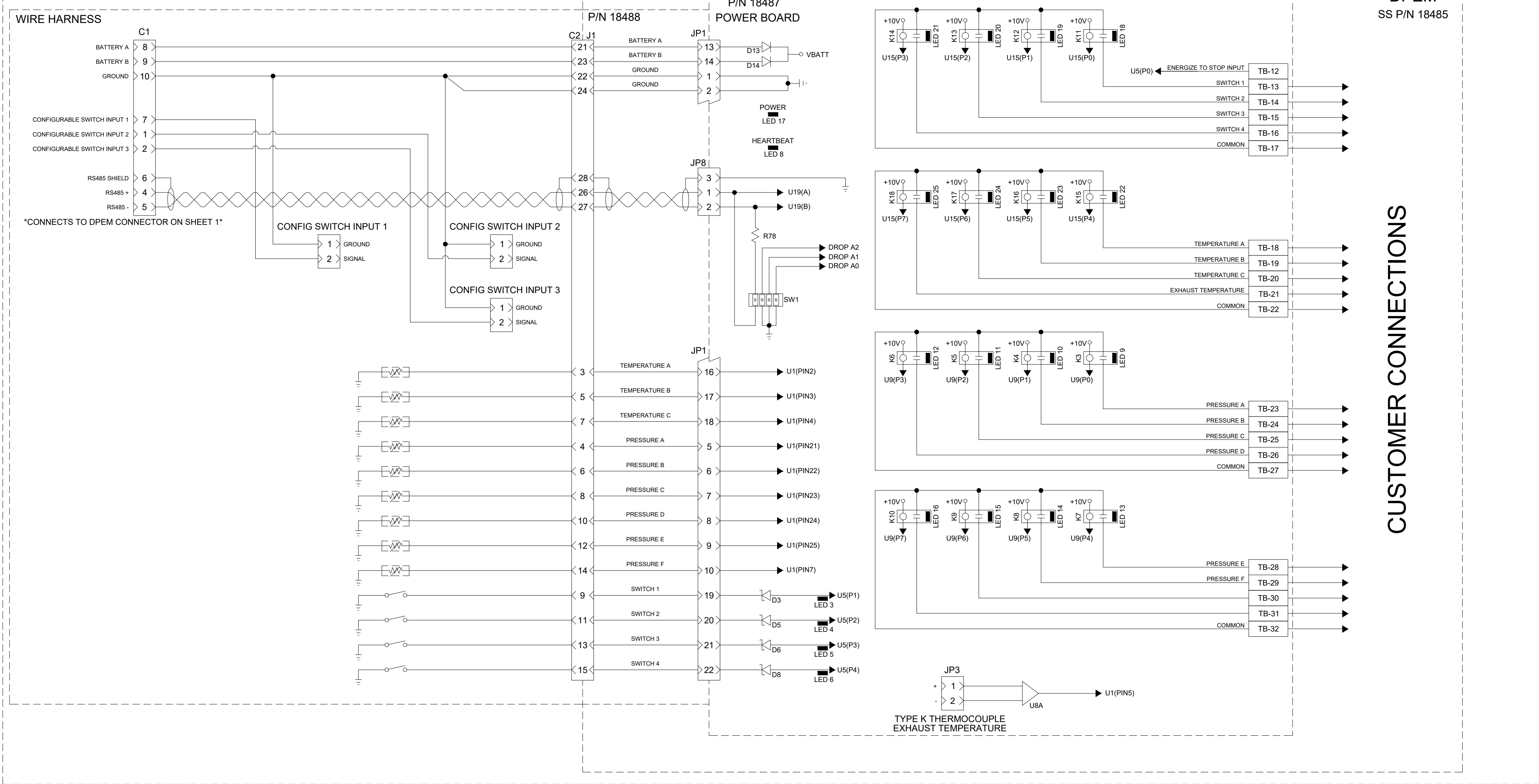

CUSTOMER CONNECTIONS

DPEM
SS P/N 18485

<small>This document contains confidential and trade secret information. It is the property of Cummins NPower LLC and is given to the receiver in confidence. The receiver, by receiving and retaining of this document, accepts the responsibility to maintain and control this information as confidential. It is not to be disclosed to anyone outside the company without the express written consent of Cummins NPower LLC. (1) not to use the document or any copy thereof or the contents or trade secret information therein; (2) not to copy the document; (3) not to disclose to others either the document or the confidential or trade secret information therein; and (4) upon completion of the work to return the document, or upon demand, to return the document, all copies thereof, and all material copied therefrom. ©2016 Cummins NPower LLC.</small>			CUMMINS NPOWER LLC CORPORATE OFFICE 1600 BLUEVALE ROAD WHITE BEAR LAKE, MN WWW.CUMMINSNPOWER.COM	CUSTOM DESIGN AND UPTI CENTER 875 LAWRENCE DRIVE DEPERE, WISCONSIN	
UNLESS OTHERWISE SPECIFIED ALL DIMENSION TOLERANCES ARE:					
ANGULAR DIMENSIONS ± 1° THIRD ANGLE PROJECTION	IMPERIAL UNITS FRACTIONS DECIMALS MILLIMETERS DECIMALS	METRIC UNITS FRACTIONS DECIMALS MILLIMETERS DECIMALS	DWG UNITS: INCH/LB/S SCALE: EST WEIGHT:	DRAWN BY: KAK AUTO CAD SHEET 4 OF 6 DRAWING NO: A042J125	DATE: 22 NOV 2016 INIT ECO: 2016-694

A	2019-037	SEE SHEET 1 FOR DETAILS	JF	24/JAN/2019
REV	ECO	DESCRIPTION OF REVISION	BY	DATE

IF AIR SHUT-OFF (ASO) IS SELECTED, THE UL/FM LISTING IS REMOVED AS THIS OPTION IS NOT ALLOWED PER THE STANDARDS.

ASO OPTION WITH UP TO 2 SWITCHED INPUTS

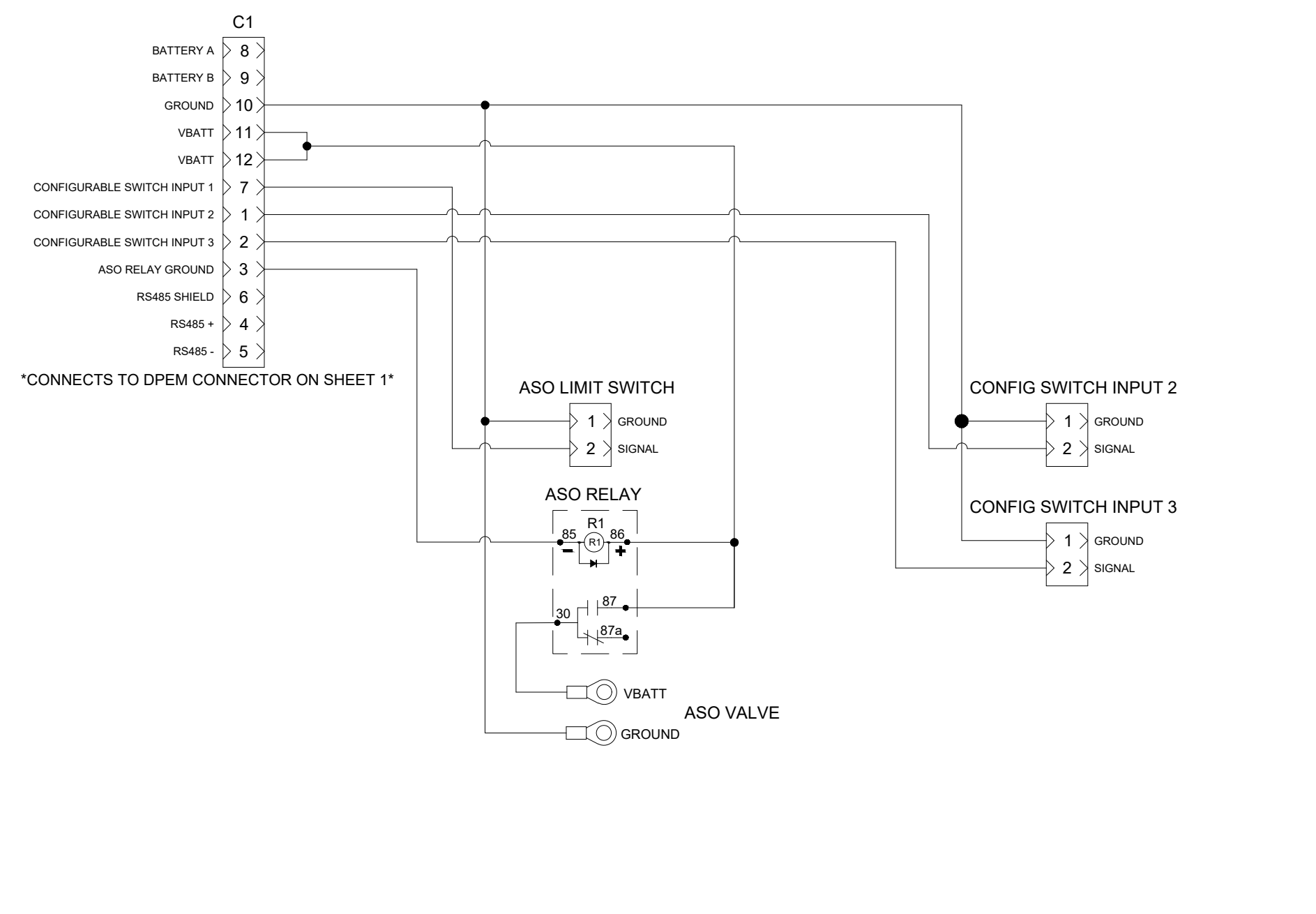

DPEM OPTION WITH ASO

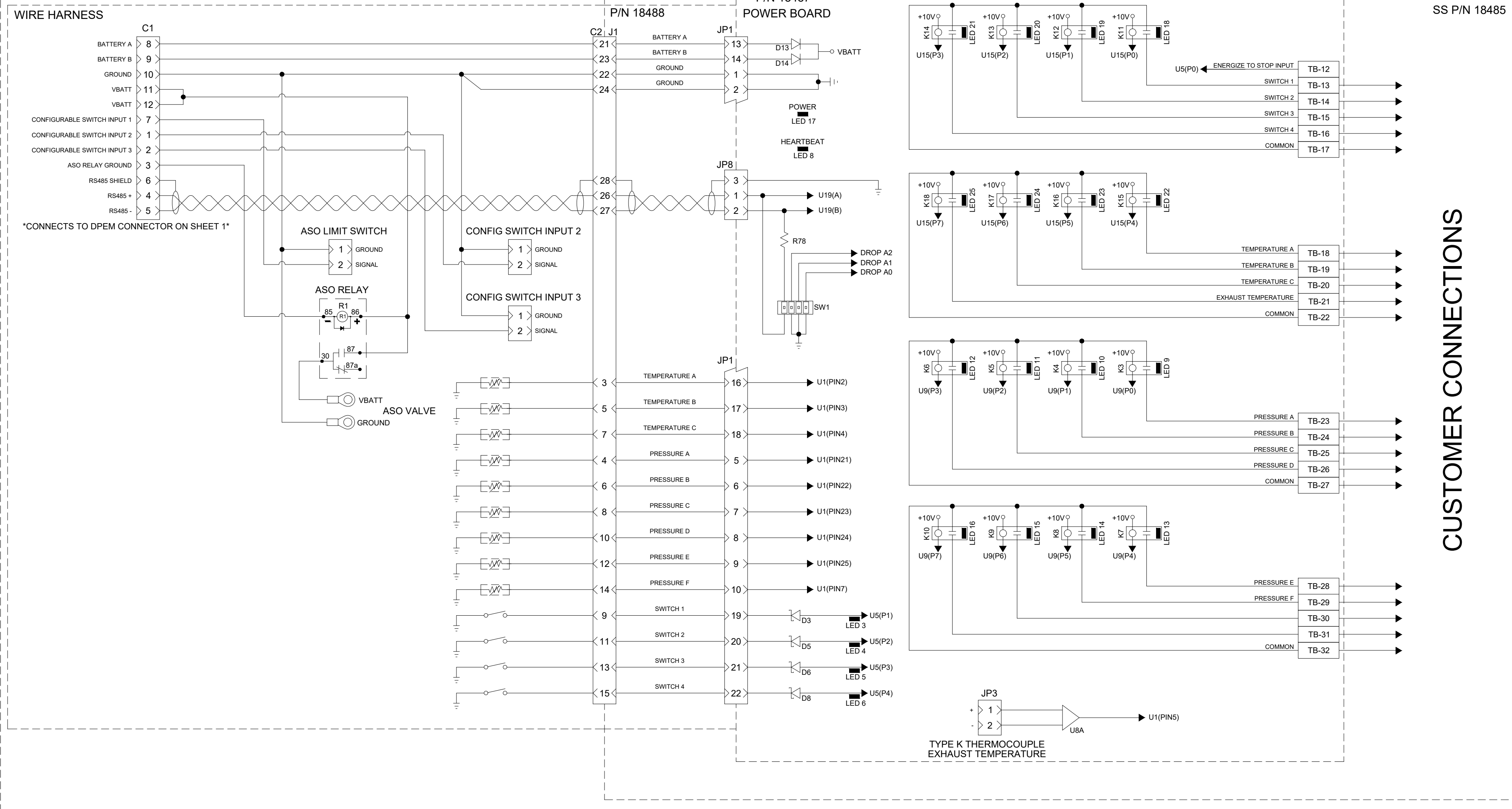

CUSTOMER CONNECTIONS

This document contains confidential and trade secret information. It is the property of Cummins NPower LLC and is loaned to the recipient in confidence. The recipient, by receiving and retaining this document, accepts the responsibility to maintain the confidentiality of the information contained herein. (1) not to disclose the information to any third party; (2) not to copy, reproduce, or otherwise use the information for any purpose other than that intended by Cummins NPower LLC; (3) not to disclose to others without the prior written consent of Cummins NPower LLC. If you are not an authorized recipient, you should not disseminate this information. If you are an authorized recipient, you should not disseminate this information to anyone other than those specifically authorized to do so. © 2016 Cummins NPower LLC

UNLESS OTHERWISE SPECIFIED ALL DIMENSION TOLERANCES ARE:

ANGULAR DIMENSIONS ± 1°	IMPERIAL UNITS	METRIC UNITS
THIRD ANGLE PROJECTION	0.005	0.125
	0.010	0.250
	0.020	0.500
	0.050	1.250
	0.100	2.500

A	2019-037	SEE SHEET 1 FOR DETAILS	JF	24/JAN/2019
REV	ECO	DESCRIPTION OF REVISION	BY	DATE

SCHEMATICS, OVERALL, CFP15E
FPDP GEN II

DWG UNITS: INCH/LB/S	DRAWN BY: KAK	DATE: 22 NOV 2016
SCALE:	SHEET 5 OF 6	INIT ECO: 2016-694
EST WEIGHT:	DRAWING NO: A042J125	

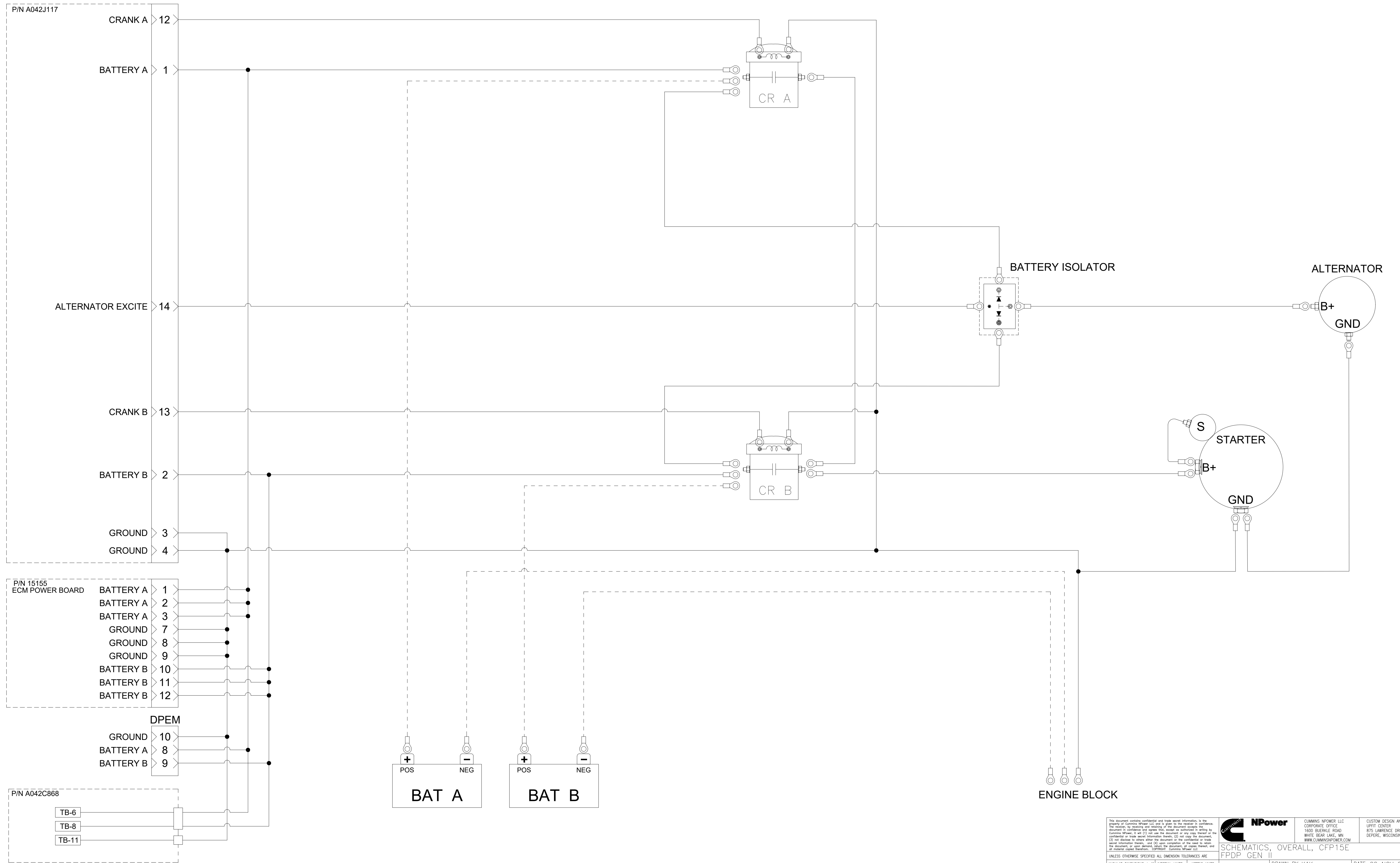

This document contains confidential and trade secret information. It is the property of Cummins NPower LLC and is loaned to the receiver in confidence. The receiver, by receiving and retaining this document, accepts the responsibility to maintain and control this information as confidential. It is not to be disclosed, copied, or otherwise made available to any third party without the prior written consent of Cummins NPower LLC. If you are not an authorized recipient, you should not disseminate this information. If you are an authorized recipient, you should not disseminate this information to anyone who does not have a need to know. If you are not an authorized recipient, you should not disseminate this information to anyone who does not have a need to know. If you are an authorized recipient, you should not disseminate this information to anyone who does not have a need to know. If you are not an authorized recipient, you should not disseminate this information to anyone who does not have a need to know. If you are an authorized recipient, you should not disseminate this information to anyone who does not have a need to know.

Cummins NPower
 CUMMINS NPOWER LLC
 CORPORATE OFFICE
 1600 BLUEVALE ROAD
 WHITE OAK LAKE, MN
 WWW.CUMMINSPOWER.COM

CUSTOM DESIGN AND
 UPTIT CENTER
 875 LAWRENCE DRIVE
 DEPERE, WISCONSIN

SCHEMATICS, OVERALL, CFP15E
 FPDP GEN II

DRAWN BY: KAK
 DATE: 22 NOV 2016

INIT ECO: 2016-694

REV	ECO	DESCRIPTION OF REVISION	BY	DATE
A	2019-037	SEE SHEET 1 FOR DETAILS	JF	24JAN2019

UNLESS OTHERWISE SPECIFIED ALL DIMENSION TOLERANCES ARE:

ANGULAR DIMENSIONS ± 1°	IMPERIAL UNITS	METRIC UNITS
THIRD ANGLE PROJECTION	INCH/LB/S	INCH/LB/S

DWG UNITS: INCH/LB/S
 SCALE: 1:1
 EST WEIGHT: SHEET 6 OF 6
 DRAWING NO: A042J125

BILL OF MATERIAL

ITEM	QTY	DESCRIPTION	PART NUMBER
1	1	BRACKET, PRESSURE TRANSMITTER	A042E427
2	1	TRANSMITTER, PRESSURE, DWYER: 626-13-GH-PI-E3-S4	A042E425

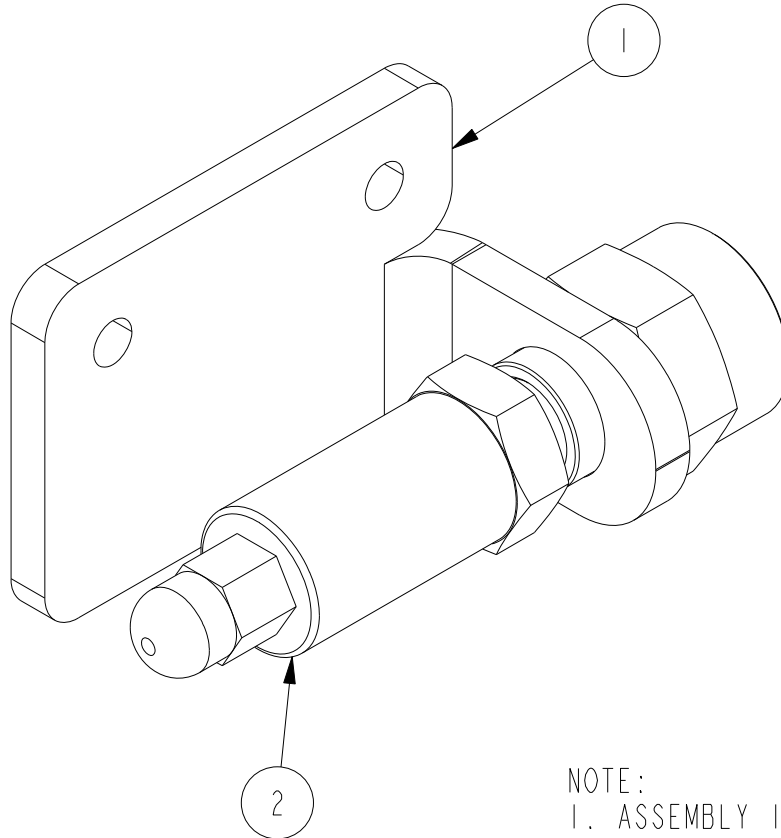

NOTE:

1. ASSEMBLY INSTALLS BELOW THE DIGITAL CONTROL PANEL. USING THE SAME TWO HOLES AS THE DIGITAL CONTROL PANEL MOUNTING BRACKET.

This document contains confidential and trade secret information, is the property of Cummins FirePower LLC and is given to the receiver in confidence. The receiver, by receiving and retaining of the document accepts the document in confidence and agrees that, except as authorized in writing by Cummins FirePower, it will (1) not use the document or any copy thereof or the confidential or trade secret information therein, (2) not copy the document, (3) not disclose to others either the document or the confidential or trade secret information therein, and (4) upon completion of the need to retain the document, or upon demand, return the document, all copies thereof, and all material copied therefrom. COPYRIGHT Cummins FirePower LLC



CUMMINS FIRE POWER LLC
CORPORATE OFFICE
1600 BUERKLE ROAD
WHITE BEAR LAKE, MN
WWW.CUMMINSFIREPOWER.COM

CUSTOM DESIGN
AND UPFIT CENTER
875 LAWRENCE DRIVE
DEPERE, WISCONSIN

UNLESS OTHERWISE SPECIFIED
ALL DIMENSION TOLERANCES ARE

ANGULAR DIMENSIONS ± 1°

MACHINED SURFACES	IMPERIAL UNITS	METRIC UNITS
125	MACHINE TOLERANCES	MACHINE TOLERANCES
	.X : ± 0.06	X : ± 1.5
	.XX : ± 0.010	XX : ± 0.5
	.XXX : ± 0.001	XXX : ± 0.05
	WELD TOLERANCES	WELDED TOLERANCES
	.X : ± 0.25	X : ± 5
	.XX : ± 0.12	XX : ± 3
	.XXX : ± 0.06	XXX : ± 1.50

ASSEMBLY, VSPLD
PRESSURE TRANSMITTER

DWG UNITS: IN/LB/S	DRAWN BY: PBS PRO-ENGINEER	DATE: 09APR2015 INIT ECO: 2015-227
EST WEIGHT: 1.404	SHEET 1 OF 1	DRAWING NO: A042E428
SCALE: 1.000		

REV	ECO	DESCRIPTION OF REVISION	REV BY	DATE