



# **Installation, operation, and maintenance manual**

**Fire pump drive engine  
CFP5E series**



---

This manual contains proprietary information to equipment produced by Cummins and is being supplied solely for the purpose of installing, operating, maintaining and servicing the fire pump drive engine purchased from Cummins in De Pere, Wisconsin.

Please visit us at <https://www.cummins.com/engines/fire-pump-drives/maintenance-current-models> to view the English version of this manual in color, as well as experience a wealth of information about Cummins fire pump drive engines.



This product has been manufactured under the controls established by a Bureau Veritas Certification approved management system that conforms with ISO 9001:2015.



# Fire pump drive engine

## Limited warranty

### Description

This limited warranty applies to all Cummins fire pump drive engines (hereinafter referred to as "Cummins" branded fire pump drive engines and associated accessories (hereinafter referred to as "Product")). This warranty covers any failures of the Product, under normal use and service, which result from a defect in material or factory workmanship.

### Warranty period:

The warranty start date for stationary Product is the date of initial start-up, demonstration or eighteen (18) months after factory ship date, whichever is sooner.

**Base engine warranty duration (whichever occurs first): 2 years/2000 hours.**

### Cummins responsibilities:

In the event of a failure of the Product during the warranty period due to defects in material or workmanship, Cummins will only be responsible for the following costs:

- All parts and labor required to repair the Product.
- Reasonable travel expenses to and from the Product site location.
- Maintenance items that are contaminated or damaged by a warrantable failure.

### Owner responsibilities:

The owner will be responsible for the following:

- Notifying a Cummins distributor or dealer within thirty (30) days of the discovery of failure.
- Installing, operating, commissioning and maintaining the Product in accordance with Cummins published policies and guidelines.
- Providing evidence for date of commissioning.
- Providing sufficient access to and reasonable ability to remove the Product from the installation in the event of a warrantable failure.
- Incremental costs and expenses associated with Product removal and reinstallation resulting from difficult or non-standard installations.
- Costs associated with Fire Watch Protection during Product being repaired.
- Costs associated with labor overtime and premium shipping requested by the owner.
- All downtime expenses, fines, all applicable taxes, and other losses resulting from a warrantable failure.



## Limitations:

This limited warranty does not cover Product failures resulting from:

- Inappropriate use relative to designated power rating or application guidelines.
- Normal wear and tear, negligence, accidents or misuse.
- Improper and/or unauthorized installation.
- Lack of maintenance or unauthorized repair.
- Noncompliance with any Cummins published guideline or policy.
- Use of improper or contaminated fuels, coolants or lubricants.
- Improper storage before and after commissioning.
- Owner's delay in making Product available after notification of potential Product problem.
- Replacement parts and accessories not authorized by Cummins.
- Owner or operator abuse or neglect such as: operation without adequate coolant or lubricants; over-fueling; over-speeding; lack of maintenance to lubricating, cooling or air intake systems; late servicing and maintenance; improper storage, starting, warm-up, run-in or shutdown practices, or for progressive damage resulting from a defective warning device.
- Damage to parts, fixtures, housings, attachments and accessory items that are not part of the fire pump package.

This limited warranty does not apply to:

- Costs of maintenance, adjustments, installation, commissioning or start-up.
- Starting batteries and enclosures.
- Components added to the Product after shipment from Cummins.
- Block heaters are warranted for one (1) year from date in service

Please contact your local Cummins Sales and Service for clarification concerning these limitations.

## Extended warranty

Cummins Inc. offers several levels of Extended Warranty Coverage (**Base Engine Only**). Please contact your local Cummins Distributor for details.

### Cummins right to failed components:

Failed components claimed under warranty remain the property of Cummins. Cummins has the right to reclaim any failed component that has been replaced under warranty.

**THE WARRANTIES SET FORTH HEREIN ARE THE SOLE WARRANTIES MADE BY CUMMINS INC. IN REGARD TO THE PRODUCT. CUMMINS INC. MAKES NO OTHER WARRANTIES, EXPRESS OR IMPLIED, OR OF MERCHANTABILITY OR FITNESS FOR A PARTICULAR PURPOSE. IN NO EVENT IS CUMMINS INC. LIABLE FOR INCIDENTAL OR CONSEQUENTIAL DAMAGES.**

This limited warranty shall be enforced to the maximum extent permitted by applicable law. This limited warranty gives the owner specific rights that may vary from state to state or from jurisdiction to jurisdiction.

See the Cummins Inc. warranty bulletins for additional base engine warranty details: [US & Canada: 3381321](#)  
[International: 3381322](#).



Cummins fire pump drive engines have been manufactured under the controls established by a Bureau Veritas Certification approved management system that conforms with ISO 9001:2015.



Cummins Sales and Service  
875 Lawrence Drive  
DePere, Wisconsin 54115

[www.cummins.com](http://www.cummins.com)

Doc. A042G861 Rev. 2

---

This page is intentionally left blank.

# Table of Contents

## 1 - Safety

1.1 Introduction	1
1.2 Use of advisory and cautionary statements	1
1.2.1 Advisory statements	1
1.2.2 Cautionary statements	1
1.3 General safety precautions	2

## 2 - Description

2.1 Introduction	3
2.2 Fire pump drive engine nameplate	4
2.3 Fire pump controller	4
2.4 CFP5E components	5
2.5 Fire Pump Digital Panel (FPDP)	7
2.5.1 Engine STOP button	7
2.5.2 Customer access port	8
2.5.3 Diagnostics connector	8
2.5.4 Engine ECM power supply	8
2.5.5 Tachometer	8
2.5.6 Battery "A" and "B" voltmeters	8
2.5.7 SCREEN soft key	8
2.5.8 RESET/STOP switch	8
2.5.9 IDLE soft key	8
2.5.10 Crank battery A and B momentary start switches	9
2.5.11 ECM A/ECM B selector switch and indicator lamps	9
2.5.12 Automatic or Manual mode of operation selector switch and indicator lamps	9
2.5.13 MENU soft key	9
2.5.14 Hour meter	9
2.5.15 Engine oil pressure gauge	9
2.5.16 Coolant temperature gauge	10
2.6 FPDP informational displays	10
2.6.1 Fault code warning displays	10
2.6.1.1 Yellow warning indicators	10
2.6.1.2 Red warning indicators	12
2.6.2 Overspeed warning indicator	13
2.6.3 VSPLC information and warnings	13
2.6.4 DPEM fault screens	15
2.7 Electronic control module (ECM)	16
2.8 Digital panel expansion module (DPEM) (optional)	17
2.9 Fuel supply and drain	17
2.10 High pressure common rail (HPCR) fuel system	17
2.11 Air intake system	18
2.12 Cooling water system	19
2.13 Engine oil system	21
2.14 Engine exhaust system	21
2.15	21

**3 - Installation**

3.1 Introduction . . . . . 23

3.2 Receiving and handling . . . . . 23

3.3 Site preparation . . . . . 23

3.4 Drive shaft installation . . . . . 23

3.5 Fuel supply installation . . . . . 25

3.6 Cooling water supply installation . . . . . 26

3.7 Battery installation . . . . . 27

3.8 Signal and control installation . . . . . 29

    3.8.1 FPDP interface terminal strip . . . . . 29

    3.8.2 Battery charger interface . . . . . 31

3.9 Coolant system preparation . . . . . 32

3.10 Charge air cooler (CAC) inspection . . . . . 33

3.11 Lubricating oil system preparation . . . . . 33

3.12 Variable Speed Pressure Limiting Control (VSPLC) preparation . . . . . 34

3.13 Pre-start inspections . . . . . 35

3.14 Engine monitoring . . . . . 35

3.15 Start-up validation . . . . . 36

    3.15.1 High Water Temp . . . . . 38

    3.15.2 Low Water Temp . . . . . 38

    3.15.3 Low Oil Pres . . . . . 39

    3.15.4 Fuel Inj. Malf. . . . . 39

    3.15.5 Hi Raw Water Temp . . . . . 40

    3.15.6 Raw Water Strain . . . . . 41

    3.15.7 TB-303/304 - ECM Warning/ECM Failure . . . . . 42

    3.15.8 TB-305-307 - Custom Outputs - simulation from the Terminal Block Test screen . . . . . 43

    3.15.9 TB-301 - ECM Switch . . . . . 44

    3.15.10 TB-3 - Overspeed Switch . . . . . 44

    3.15.11 TB-2 - Crank Termination Switch . . . . . 46

    3.15.12 Troubleshooting a Terminal Block Connection: . . . . . 46

**4 - Operation**

4.1 Introduction . . . . . 47

4.2 Starting and stopping procedures . . . . . 47

    4.2.1 Local starting/stopping procedure . . . . . 47

    4.2.2 Emergency starting procedure . . . . . 48

4.3 Fire Pump Digital Panel (FPDP) screens and adjustments in automatic mode . . . . . 50

    4.3.1 The SCREEN soft key . . . . . 50

    4.3.2 The MENU soft key - Settings Menu . . . . . 52

        4.3.2.1 ENGINE SETUP screen . . . . . 52

        4.3.2.2 OVERSPEED TEST screen . . . . . 56

        4.3.2.3 IMPERIAL/SI VALUES screen . . . . . 56

        4.3.2.4 ANALOG VALUES screen . . . . . 57

        4.3.2.5 AUTOSWITCH screen . . . . . 57

        4.3.2.6 FAULT CODES screen . . . . . 59

        4.3.2.7 RPM ADJUSTMENT screen . . . . . 60

        4.3.2.8 DPEM (optional) . . . . . 61

4.4 FPDP screens and adjustments in manual mode - IDLE soft key . . . . . 61

4.5 Engine/turbocharger cool down . . . . . 62

    4.5.1 Automatic shutdown - cool down timer . . . . . 63

    4.5.2 Automatic shutdown - engine protection . . . . . 63

    4.5.3 Manual shutdown - from the fire pump controller . . . . . 63

    4.5.4 Manual shutdown - from the FPDP . . . . . 63

## Table of Contents

---

### 5 - Maintenance

5.1	Introduction	65
5.2	Engine operation reports	65
5.3	Weekly maintenance	68
5.3.1	General	68
5.3.2	Air cleaner filter and piping	68
5.3.3	Cooling system	69
5.3.4	Engine oil system	70
5.3.5	Fuel system	71
5.3.6	Engine exhaust system	71
5.3.7	Electrical supply and controls	71
5.3.8	Crankcase ventilation hose	71
5.3.9	Heat exchanger - cooling water strainers	72
5.3.10	Batteries	72
5.3.11	Engine test run	73
5.3.12	Engine operation checks	74
5.3.12.1	Crank termination setpoint	74
5.3.12.2	Engine speed adjustment	74
5.3.13	Engine coolant heater	74
5.4	Annual maintenance	75
5.4.1	Electrical components	75
5.4.2	Turbocharger mounting nuts	76
5.4.3	Engine supports	76
5.4.4	Fuel pumps and filters	77
5.4.5	Engine oil and filter	78
5.4.6	Drive shaft	80
5.4.7	Coolant pump/alternator belt	81
5.4.8	Raw water zinc anode	82
5.4.9	Heat exchanger pressure test	82
5.4.10	Turbocharger	83
5.5	Every two years	83
5.5.1	Coolant pump	83
5.5.2	Cooling system - heat exchanger	84
5.6	Every four years	86
5.6.1	Coolant thermostat removal/installation	87
5.6.2	Coolant pump/alternator belt replacement	88

### 6 - Troubleshooting

6.1	Introduction	89
6.2	Engine Will Not Start	90
6.3	Engine Cranks But Will Not Start	91
6.4	Engine Starts But Continues to Crank	93
6.5	Engine Will Not Stop	94
6.6	Low Battery Voltage	95
6.7	Fault Code Charts - CFP5E/EVS, CFP7E/EVS, CFP9E/EVS, and CFP9E HHP	96

### 7 - Component parts and assemblies

7.1	Repairs and technical service	105
7.2	Recommended spare parts inventory	105
7.3	Ordering parts	105
7.4	Engine data and torque values	106

7.5 Cap screw markings and torque values . . . . . 109

    7.5.1 Cap screw identification . . . . . 109

        7.5.1.1 Metric cap screw identification and head markings . . . . . 109

        7.5.1.2 US customary cap screw identification and head markings . . . . . 109

    7.5.2 Cap screw torque values. . . . . 110

Metric Cap Screw Torque Values (lubricated threads) . . . . . 110

U.S. Customary Cap Screw Torque Values (lubricated threads). . . . . 110

7.6 CFP5E/EVS assembly drawings. . . . . 111

# 1 - Safety

## 1.1 Introduction

Cummins manuals should be considered part of the equipment. Keep the manuals with the equipment. If the equipment is traded or sold, give the manuals to the new owner.

The fire pump drive engine has been carefully designed to provide safe and efficient service when properly installed, maintained, and operated. However, the overall safety and reliability of the complete system is dependent on many factors outside the control of the fire pump drive engine manufacturer. To avoid possible safety hazards, make all mechanical and electrical connections to the fire pump drive engine exactly as specified in this manual.

All systems external to the fire pump drive engine (fuel, electrical, etc.) must comply with all applicable codes. Make certain all required inspections and tests have been completed and all code requirements have been satisfied before certifying the installation is complete and ready for service. All personnel responsible for operation and maintenance of the equipment should read and thoroughly understand this manual.

## SAVE THESE INSTRUCTIONS.

Safe and efficient operation can be achieved only if the equipment is properly operated and maintained. Many accidents are caused by failure to follow fundamental rules and precautions.

## 1.2 Use of advisory and cautionary statements

### 1.2.1 Advisory statements

**Advisory** statements are used throughout this manual to call attention to special information and correct operating procedures. Throughout this manual, these Advisory Statements are delineated by the terms “NOTE” and “IMPORTANT” in uppercase letters:

**NOTE:** *A general advisory statement relating to equipment operation and maintenance procedures.*

**IMPORTANT:** *A specific advisory statement intended to prevent damage to the equipment or its associated components.*

### 1.2.2 Cautionary statements

**Cautionary** statements highlight particular safety precautions pertaining to personal injury and/or damage to the equipment. Cautionary Statements are always preceded by the following symbols:

  
***This symbol warns of immediate hazards which will result in severe personal injury or death.***

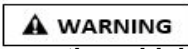
  
***This symbol refers to a hazard or unsafe practice which CAN result in severe personal injury or death.***



*Indicates the presence of a hazard or unsafe practice which can result in equipment damage OR minor or major personal injury.*

### **1.3 General safety precautions**

Read and understand all of the safety precautions and warnings before performing any repair. Special safety precautions are included in the procedures when they apply. This list contains the general safety precautions that **must** be followed to provide personal safety:

Perform a walk around inspection and alert all area personnel that the equipment will be starting before manual operation.

Cummins engine manuals should be considered part of the equipment. Keep the manuals with the equipment. If the equipment is traded or sold, give the manuals to the new owner.

All personnel responsible for operation and maintenance of the equipment should read and thoroughly understand this manual.

- Do not operate faulty or damaged equipment. Ensure that all hoses, pipe connections, clamps and guards are in place and securely fastened. Electrical components should be kept in good working condition and repaired immediately by qualified personnel.
- After performing maintenance, remove all tools and foreign materials and reinstall and securely fasten ALL guards, covers, and protective devices.
- Exposed in-running belt nips can cause severe personal injury or dismemberment. Ensure that guards are in place and securely fastened before operation.
- Rotating drive shafts can lacerate, dismember, or cause strangulation. Keep hands, body parts, long hair, or loose-fitting clothing clear at all times.
- Never attempt to manually clean a machine while it is operating or in standby mode.
- Never open ports on tanks or piping while the engine is operating. Contact with pressurized agents can cause severe personal injury.
- Relieve all pressure in the air, oil, and the cooling systems before any lines, fittings, or related items are removed or disconnected.
- Engine fuel is flammable when in contact with electrical spark or flame sources. Remove all sources of spark or flame from the work area.
- Always use the same fastener part number (or equivalent) when replacing fasteners.
- Some state and federal agencies in the United States have determined that used engine oil can be carcinogenic and can cause reproductive toxicity. Dispose of waste oil in accordance with applicable requirements.



## 2 - Description

### 2.1 Introduction

This manual contains information for the correct operation and maintenance of a Cummins fire pump drive engine. Read and follow all safety instructions in [Section 1 - Safety](#). Keep this manual with the equipment. If the equipment is traded or sold, give the manual to the new owner.

Cummins fire pump drive engines have been designed in accordance with National Fire Protection Association (NFPA) 20 guidelines.

No deviations are permitted without prior written approval. These engines are to be used only for fire protection applications. [Figure 2-2](#) and [Figure 2-3](#) provide visual descriptions of the engine components for this fire pump drive engine.

Cummins reserves the right to make changes at any time. If any differences are found between an engine and the information in this manual, contact your local Authorized Repair Location.

The latest technology and the highest quality components were used to produce this engine. Cummins fire pump drive engines as packaged units (engine and accessories) have been approved by Factory Mutual (FM) Approvals and listed by Underwriters Laboratories (UL), Inc. and Underwriters Laboratories of Canada (ULC). When replacement parts are needed, we recommend using only genuine Cummins parts.

 **CAUTION**

***Injury may result and warranty is voided if fuel rate, revolutions per minute (RPM), or altitudes exceed published maximum values for this model and application.***

## 2.2 Fire pump drive engine nameplate

Each fire pump drive engine is labeled with a nameplate that provides its unique information. A typical fire pump drive engine nameplate is shown in [Figure 2-1](#).

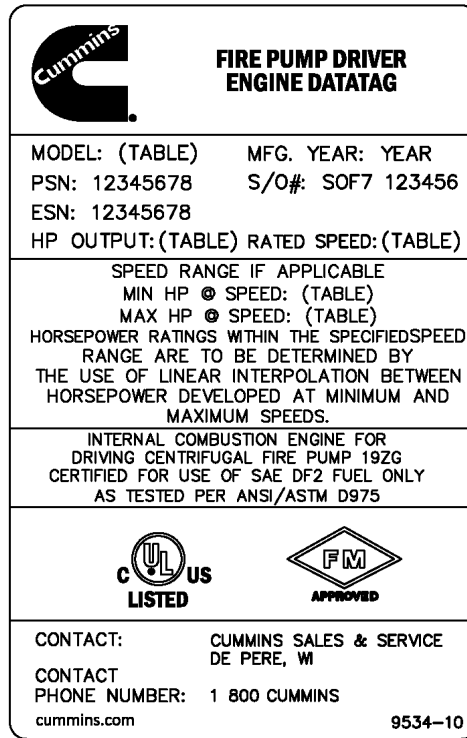

**Figure 2-1 Fire pump drive engine nameplate (typical)**

## 2.3 Fire pump controller

The fire pump controller starts the engine automatically when the Fire Pump Digital Panel (FPDP) is in automatic mode and a remote fire demand signal is received. The fire pump controller automatically shuts down the engine when the fire demand signal is discontinued. The fire pump controller is optionally supplied by

**NOTE:** *With the fire pump controller in **manual** mode, starting and stopping the fire pump drive engine can be controlled by the FPDP, located on the fire pump drive engine itself.*

**CAUTION**

**Upon turning the fire pump controller to OFF, the fire pump drive engine may continue to run at a reduced speed to cool the engine down. To stop the fire pump drive engine at this point - in the case of an emergency - press the Engine STOP button on the FPDP rather than on the pump controller.**

## 2.4 CFP5E components

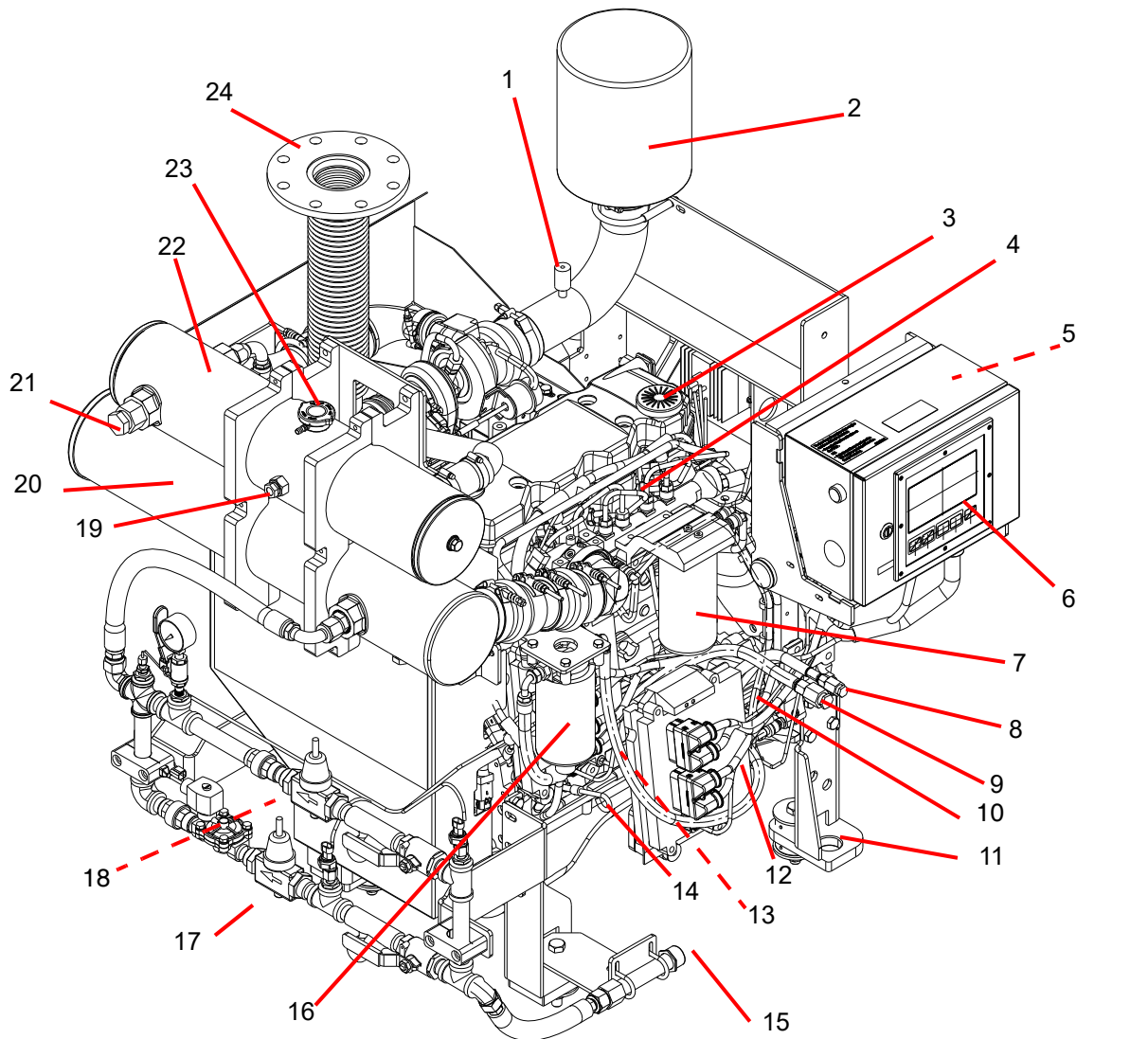

- |  |  |
|--|--|
| 1. Air cleaner service indicator                         | 12. Electronic control module (ECM) B      |
| 2. Air cleaner assembly (intake)                         | 13. Electronic control module (ECM) A      |
| 3. Engine oil fill port                                  | 14. Engine oil dipstick                    |
| 4. High pressure common rail (HPCR) fuel system          | 15. Raw water inlet connection             |
| 5. FPDP interface terminal strip - terminal blocks (TBs) | 16. Fuel pre-filter/water separator        |
| 6. FPDP  | 17. Cooling loop                           |
| 7. Primary fuel filter                                   | 18. Oil pan drain port                     |
| 8. Fuel return line                                      | 19. Coolant level sight gauge              |
| 9. Fuel supply line                                      | 20. Charge air cooler (CAC) heat exchanger |
| 10. Fuel pump  | 21. Raw water discharge connection         |
| 11. Engine supports                                      | 22. Coolant heat exchanger/expansion tank  |
|  | 23. Coolant pressure/fill cap              |
|  | 24. Exhaust flex connection                |

**Figure 2-2 Engine components - fire pump digital panel (FPDP) side**

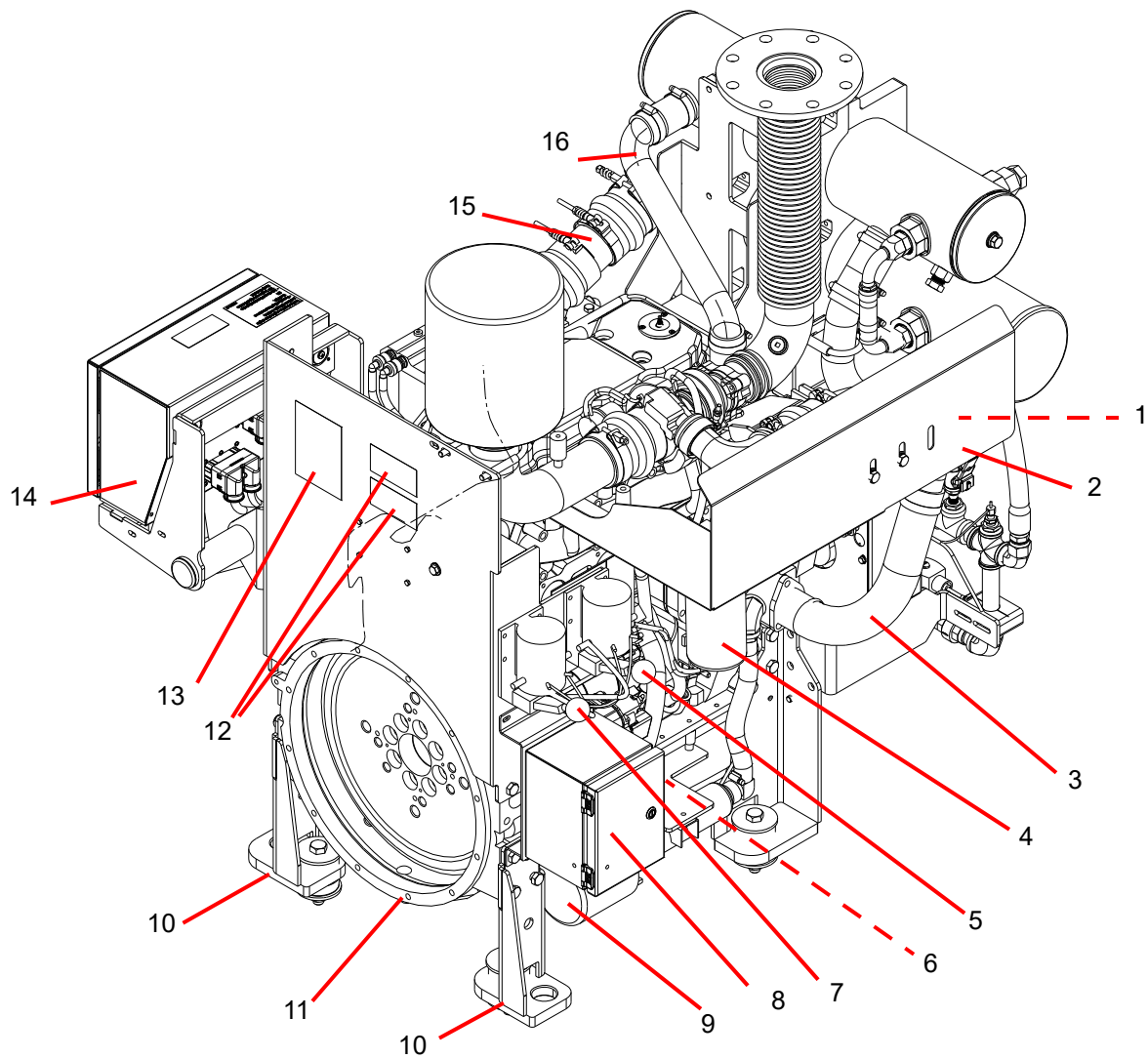

- |                                |                                    |
|--------------------------------|------------------------------------|
| 1. Alternator                  | 9. Engine coolant heater           |
| 2. Manifold heat shield        | 10. Engine supports                |
| 3. Lower coolant hose/tube     | 11. Flywheel housing               |
| 4. Engine oil filter           | 12. Engine speed setting decals    |
| 5. Battery starter contactor B | 13. Engine serial number decal     |
| 6. Starter motor               | 14. Manual start instruction decal |
| 7. Battery starter contactor A | 15. Charge air cooler (CAC) hose   |
| 8. Battery charger interface   | 16. Upper coolant hose             |

**Figure 2-3 Engine components - turbocharger side**

## 2.5 Fire Pump Digital Panel (FPDP)

The FPDP control panel (shown in [Figure 2-4](#)) is mounted on the left-hand side (or right-hand side - optional) of the flywheel end of the engine and contains controls for starting the engine, monitoring engine performance, and controlling fire pump drive engine operation.

In **manual** mode, the FPDP and the Electronic Control Module (ECM) remain active as long as battery power is available. In **automatic** mode, starting and stopping of the engine is controlled by the fire pump controller.

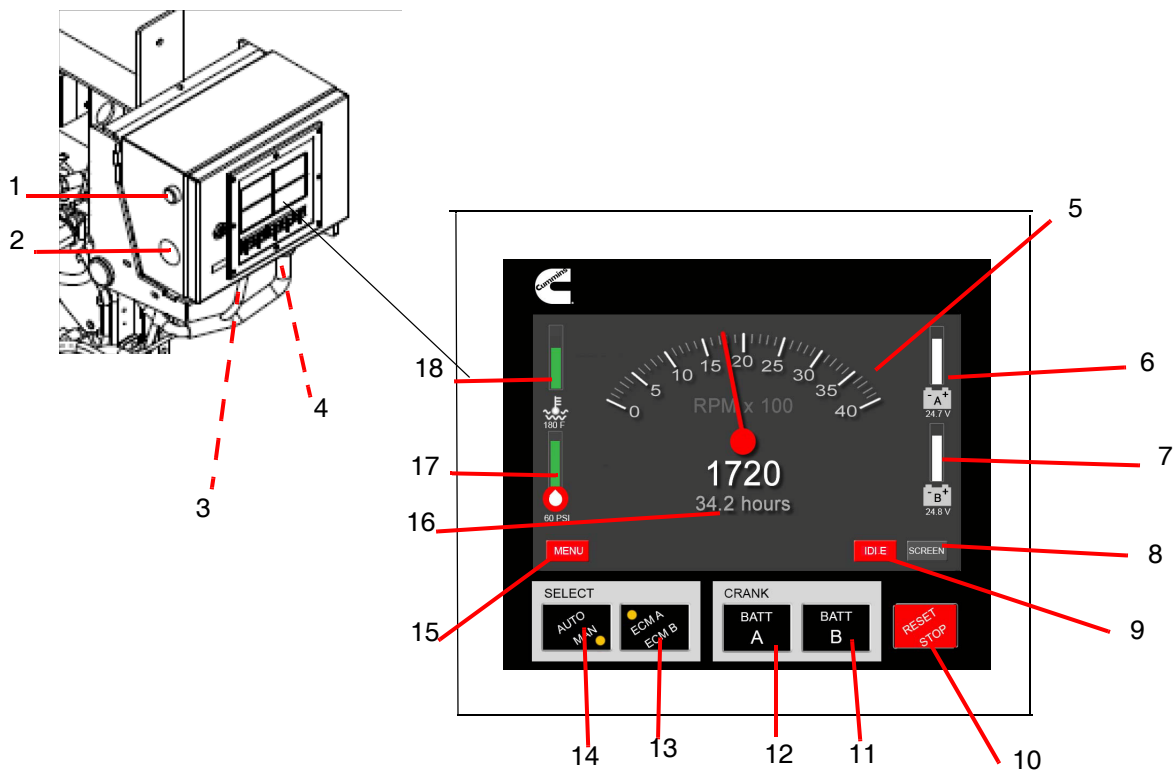

- |                            |   |
|----------------------------|---|
| 1. Engine STOP button      | 11. Crank battery B momentary start switch            |
| 2. Customer access port    | 12. Crank battery A momentary start switch            |
| 3. Diagnostics connector   | 13. ECM A/ECM B selector switch and indicator lamps   |
| 4. Engine ECM power supply | 14. AUTO/MAN mode selector switch and indicator lamps |
| 5. Tachometer              | 15. MENU soft key                                     |
| 6. Battery "A" voltmeter   | 16. Hour meter  |
| 7. Battery "B" voltmeter   | 17. Engine oil pressure gauge                         |
| 8. SCREEN soft key         | 18. Coolant temperature gauge                         |
| 9. IDLE soft key           |   |
| 10. RESET/STOP switch      |   |

**Figure 2-4 FPDP control panel**

### 2.5.1 Engine STOP button

The Engine STOP Button (1) is located on the left side of the FPDP enclosure and is used to stop the operation of the engine in either manual or automatic mode. The button must be pressed and held until the engine has shut down.

**NOTE:** Upon release of the Engine STOP Button, the fire pump drive engine will attempt to restart, If there is still a “pump on demand” signal present from the fire pump controller. The engine must also be stopped at the fire pump controller.

### 2.5.2 Customer access port

The customer access knock-out (2) is located on the left side of the FPDP for ease of access. With an opening diameter of 1.38 in. (3.5 cm), this is the only knock-out provided for the pump controller interconnect.

**IMPORTANT:** If additional holes are placed in the FPDP, all warranty on the fire pump drive engine will be void.

### 2.5.3 Diagnostics connector

The Diagnostics Connector (3) is located on the bottom of the FPDP enclosure and is strictly used for Cummins service personnel.

### 2.5.4 Engine ECM power supply

The Engine ECM Power Supply plug-in (4) is located on the lower side of the FPDP to provide unswitched battery power to both ECM A and ECM B.

### 2.5.5 Tachometer

The Tachometer (5) displays the engine speed in revolutions per minute (RPM) whenever the engine is operating.

### 2.5.6 Battery “A” and “B” voltmeters

The Battery “A” (6) and Battery “B” (7) Voltmeters display the charge status - or Voltage Direct Current (VDC) - of the relative battery connections.

### 2.5.7 SCREEN soft key

The SCREEN soft key (8) allows the user to switch to a detailed pop up list of additional analog values (when available): exhaust temperature; cooling loop temperature; cooling loop differential pressure; and J1939 values including: oil temperature; intake manifold temperature; and intake manifold pressure.

### 2.5.8 RESET/STOP switch

The RESET/STOP Switch (9) serves multiple purposes:

- To shut off the engine by removing the ECM keyswitch/Fuel Shutoff (FSO) valve until the engine speed decelerates to 0 RPM.
- To reset the fire pump drive engine after an overspeed fault has been activated, allowing subsequent restarts of the fire pump drive engine.

### 2.5.9 IDLE soft key

The IDLE soft key (10) allows the user to run an electronic engine at a reduced speed while the FPDP is in manual mode (See [Operation: FPDP Screens and Adjustments in Manual Mode - IDLE Soft Key](#)). When the FPDP AUTO/MAN selector switch is in the MAN position (manual mode), the IDLE soft key will appear and display in red. When the engine idle command is active, the IDLE soft key will display in green.

**NOTE:** The IDLE soft key is only intended to be used for commissioning or service events.

---

### 2.5.10 Crank battery A and B momentary start switches

The CRANK BATT A (12) and CRANK BATT B (11) momentary start switches engage the starter when the FPDP is in MANUAL mode.

CRANK BATT A energizes battery contactor A and CRANK BATT B energizes battery contactor B. Both CRANK BATT A and CRANK BATT B buttons can be energized at the same time in the event both batteries are weak.

### 2.5.11 ECM A/ECM B selector switch and indicator lamps

The ECM A / ECM B selector switch and indicator lamps (13) illuminate in yellow, indicating which ECM is being used to control the engine.

If ECM A (normal position) is selected, ECM A is monitoring and controlling the engine.

If ECM B (alternate position) is selected, ECM B is monitoring and controlling the engine, and the FPDP will indicate that the engine is operating on the alternate ECM.

### 2.5.12 Automatic or Manual mode of operation selector switch and indicator lamps

The AUTO/MAN selector switch and indicator lamps (14) illuminate in yellow, indicating the operational state of the FPDP.

The MAN selector switch (for manual operation) is only to be selected for engine setup, testing, and emergency and maintenance procedures. When the FPDP is in manual mode, the ECM keyswitch/FSO and raw water solenoids are always activated, except under an overspeed condition.



***Manual operation of the fire pump drive engine is intended for a short run time. Leaving the FPDP in manual mode for an extended period may cause fuel dilution.***

The AUTO selector switch (for automatic operation) is the normal state of the FPDP, in which the fire pump controller starts and stops the engine. In automatic mode, the fire pump drive engine shuts down or enters engine cool down upon loss of a signal from the fire pump controller.

### 2.5.13 MENU soft key

The MENU soft key (15) on the FPDP display allows the user to open the menu options. A complete list of FPDP screens and their functionality is outlined in the [Operation Section](#) of this manual.

### 2.5.14 Hour meter

The Hour Meter (16) maintains a running total of the hours of engine operation (run time).

### 2.5.15 Engine oil pressure gauge

Based on user parameter screen display selection, the Engine Oil Pressure Gauge (17) displays the engine oil pressure in pounds per square inch (PSI) or kPa. The Engine Oil Pressure Gauge displays by default in three different colors:

- green - when the engine oil pressure is greater than 25 PSI (172 kPa);
- yellow - when the engine oil pressure is between 17 PSI (117 kPa) and 25 PSI (172 kPa); and
- red - when the engine oil pressure is below 16 PSI (110 kPa). *NOTE: Engine oil pressure displayed in red will also be accompanied by a low oil pressure fault. Refer to TB-4.*

### 2.5.16 Coolant temperature gauge

Based on user parameter screen display selection, the Coolant Temperature Gauge (**18**) displays the engine coolant temperature in degrees Fahrenheit or degrees Celsius. The Coolant Temperature Gauge displays in three different colors:

- green - when the coolant temperature is between 100-199 °F (38-93 °C);
- yellow - when the coolant temperature is between 200-211 °F (93-100 °C) OR below 100 °F (38 °C). *NOTE: when the coolant temperature is below 100 °F (38 °C), the yellow gauge will also be accompanied by a low coolant temperature fault. Refer to TB-312.; and*
- red - when the coolant temperature is greater than 212 °F (100 °C). *NOTE: the red gauge will also be accompanied by a high coolant temperature fault. Refer to TB-5.*

## 2.6 FPDP informational displays

### 2.6.1 Fault code warning displays

Fault codes diagnosed by the ECM are displayed in a yellow or red International Organization for Standardization (ISO) symbol and/or overlay box which lies atop the tachometer signal (the engine speed is still digitally displayed) to alert the operator to service the engine as soon as possible. Only the first seven active ECM faults will be displayed in the overlay.

**NOTE:** To remove the overlay box from atop the tachometer, press the SCREEN Soft Key.

#### 2.6.1.1 Yellow warning indicators

The yellow ISO symbol (shown in [Figure 2-5](#)) or the yellow ISO symbol AND a large yellow box covering the tachometer (shown in [Figure 2-6](#)) indicate an engine malfunction that requires timely operator attention.

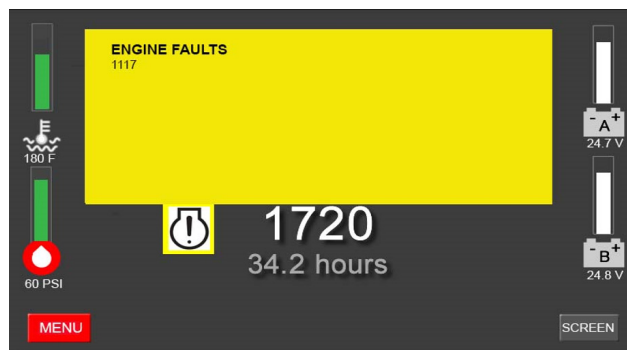
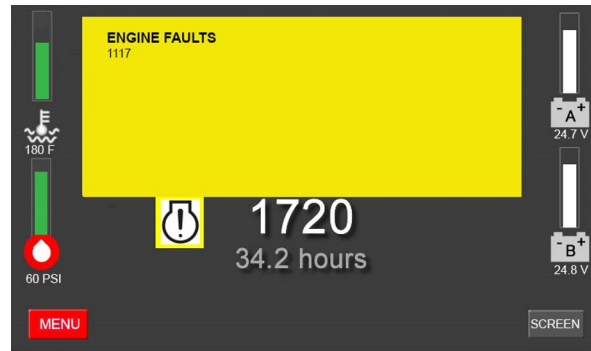

Figure 2-5 Yellow warning indicator ISO symbol only

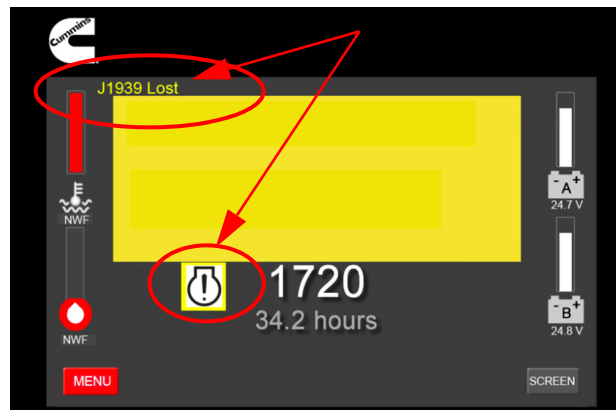



**Figure 2-6 Yellow warning indicator ISO symbol and overlay box**

When applicable, the FPDP may display the Yellow Warning Indicator for any one of the following operational issues:

- The ECM has sensed a **non-mission disabling fault**. A three- or four-digit diagnostic fault code will display on the FPDP which can then be used to help diagnose the engine malfunction. Refer to the Fault Code Chart in the [Fault Codes Section](#) or contact your local Cummins Distributor.
- **Communications have been lost with the ECM**. The FPDP communicates with electronically-controlled engines via J1939. As shown in [Figure 2-7](#), if communications are lost, "J1939 Lost" will appear on the top left of the screen. The warning lamp will also illuminate and the text "NWF" (which stands for "Network Failure") will replace all digital J1939 values, except the tachometer, which will revert to using a mechanical speed sensor for engine speed detection.



**Figure 2-7 Loss of J1939 communications**

- **Communications have been lost with the Digital Panel Expansion Module (DPEM).** As shown in [Figure 2-8](#), “DPEM Lost” will appear on the FPDP User Interface Screen if communications between the FPDP and DPEM are compromised.

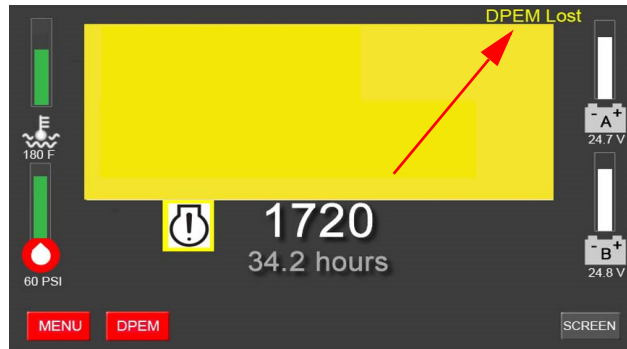

Figure 2-8 DPEM lost fault screen

- **A DPEM alarm** has been activated.
- The pump discharge **pressure is greater than 115%** of the desired pressure in a Variable Speed Pressure Limiting Control (VSPLC)-enabled system (see [Figure 2-13](#)).

### 2.6.1.2 Red warning indicators

The red ISO symbol (shown in [Figure 2-9](#)) or the red ISO symbol AND a large red box covering the tachometer (shown in [Figure 2-10](#)) indicate an engine malfunction that requires immediate and decisive operator response. The FPDP will display the Red Warning Indicator when the ECM has sensed a fuel system or ECM-specific diagnostic fault. Refer to the Fault Code Chart in the [Fault Codes Section](#) or contact your local Cummins Distributor.

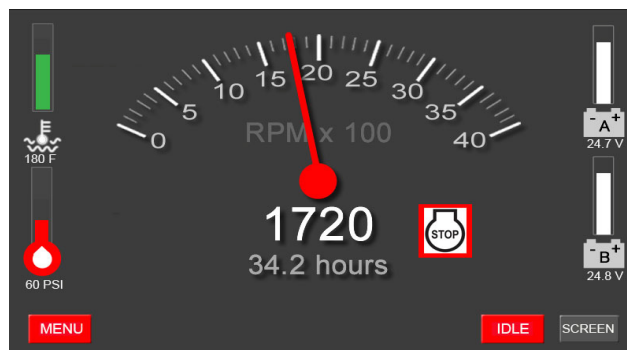

Figure 2-9 Red warning indicator ISO symbol only

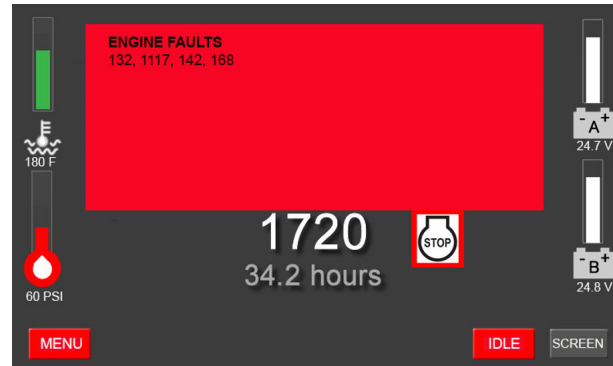

Figure 2-10 Red warning indicator ISO symbol and overlay box

### 2.6.2 Overspeed warning indicator

As shown in Figure 2-11, “ENGINE OVERSPEED” flashing in red at the top of the FPDP screen indicates that the engine has exceeded its rated RPM and that possible damage to the sprinkler system may occur.

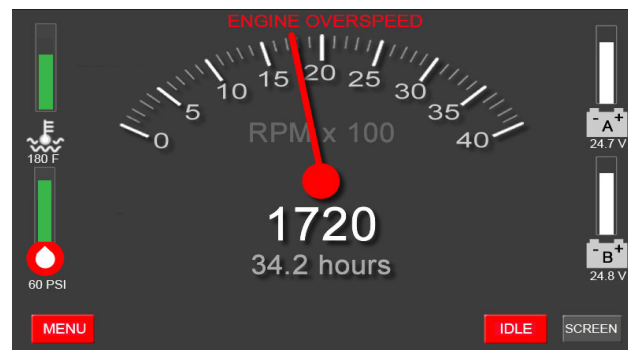

Figure 2-11 Overspeed warning indicator

### 2.6.3 VSPLC information and warnings

**IMPORTANT:** VSPLC capability is FM-approved and the fire pump drive engine must be ordered from Cummins as a variable speed engine; specific manufacturing tests are required for fixed and variable speed fire pump drive engines prior to installation.

VSPLC is a controls feature in which the FPDP varies the engine speed in an attempt to maintain a constant pump discharge pressure. The allowable speed range for a VSPLC engine is from low speed idle (LSI) to rated speed where LSI = 1200 RPM on all engines except the CFP15E and CFP30E (in which LSI = 1400 RPM).

The rated speed can be slightly increased or decreased, just as the fixed speed engine setpoint can be, by a Cummins representative.

## Description

As shown in [Figure 2-12](#), “VSPLC Active” and the VSPLC discharge pressure will be displayed in white at the bottom of the screen when VSPLC is enabled and active.

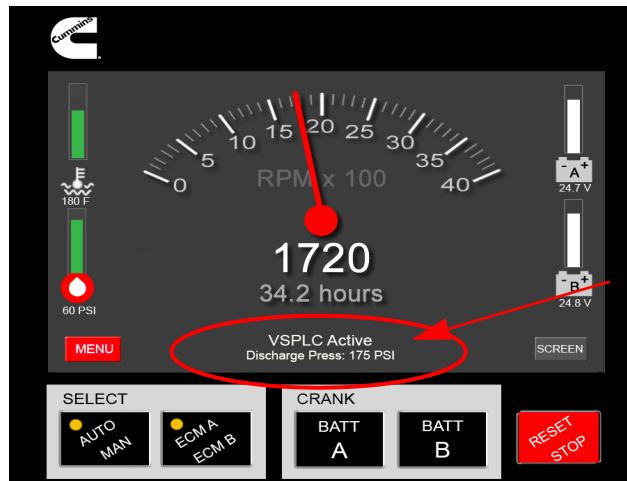

**Figure 2-12 VSPLC active screen - white (sample)**

If VSPLC is active and the pump discharge pressure is greater than 115% of the setpoint:

- “VSPLC Active” and the VSPLC discharge pressure will be displayed in yellow at the bottom of the screen (shown in [Figure 2-13](#))
- A yellow engine warning lamp icon will also appear on the screen (shown in [Figure 2-13](#))
- A yellow overlay box will appear atop the tachometer signal (the engine speed is still digitally displayed) that states “HIGH PUMP DISCHARGE PRESSURE” to alert the operator to service the engine at the earliest convenience

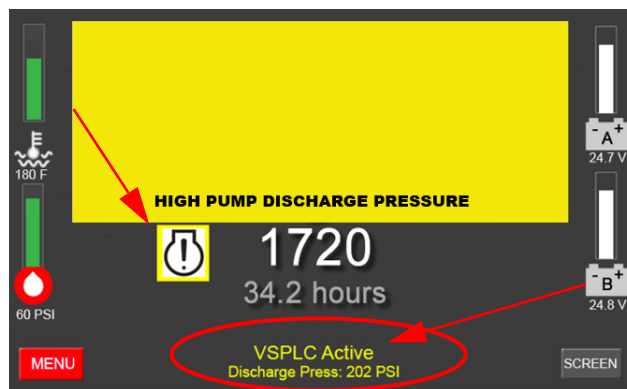

**Figure 2-13 VSPLC active screen - yellow (sample)**

In order to satisfy fire pump commissioning requirements, the engine will run at fixed speed only when the FPDP is in manual mode with TB-1 off. As shown in [Figure 2-14](#), “VSPLC Inactive” and the VSPLC discharge pressure will be displayed in red at the bottom of the screen when VSPLC is not enabled and/or not active.

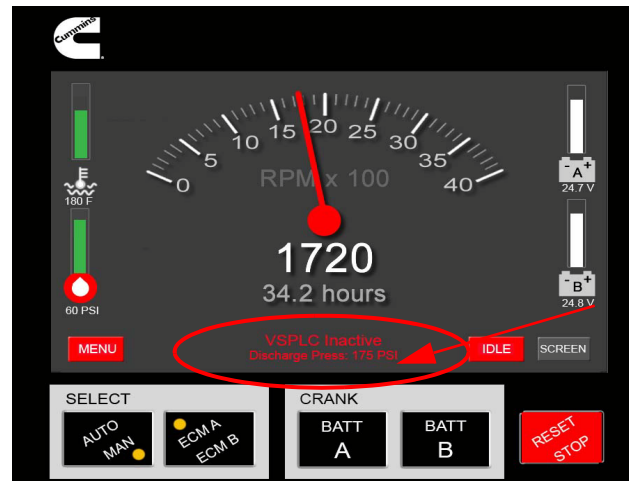

**Figure 2-14 VSPLC inactive screen - red (sample)**

**NOTE:** If TB-1 is activated from the fire pump controller during this time, the VSPLC mode will activate and control the engine speed based on the pump discharge pressure. “VSPLC Active” and the VSPLC discharge pressure will revert back to white at the bottom of the screen (shown in [Figure 2-12](#)).

#### 2.6.4 DPEM fault screens

When an analog input parameter crosses the alarm setpoint or a switched input is active, the FPDP may display the DPEM fault one of two ways:

- **From the FPDP** - As shown in [Figure 2-15](#), the warning symbol will illuminate and the overlay will activate in yellow with the text of the active fault.

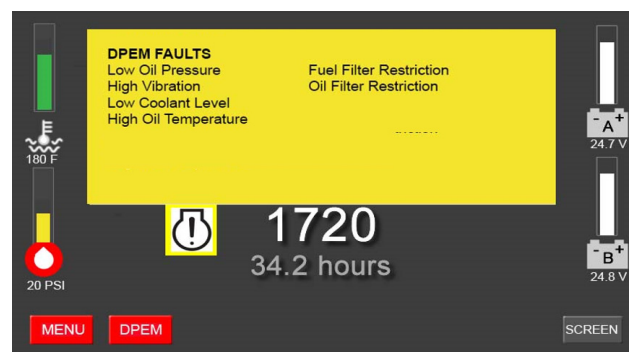

**Figure 2-15 DPEM fault screen (sample)**

- **From the DPEM/remote location** - The terminal block interface inside of the DPEM has been created for connection to monitor alarms remotely. There is an LED next to each terminal block that will also illuminate if the relay is commanded closed.

## Description

---

Each set of four relays has a common dry contact associated for integration flexibility:

- Terminal Blocks 13-16 (R1-R4) are dedicated to switched inputs, with TB-17 being the common contact
- Terminal Blocks 18-21 (R5-R8) are dedicated to temperature inputs, with TB-22 being the common contact
- Terminal Blocks 23-26 (R9-R12) are dedicated to pressure inputs, with TB-27 being the common contact
- Terminal Blocks 28-31 (R13-R16) are dedicated to additional pressure inputs or J1939 setpoints, with TB-32 being the common contact

As shown in [Figure 2-16](#), “DPEM Lost” will appear on the FPDP screen if communications between the FPDP and DPEM are compromised.



**Figure 2-16 DPEM lost fault screen (sample)**

## 2.7 Electronic control module (ECM)

The engine Operation and Maintenance manual provides detailed information about the ECM(s).

A second ECM is installed on electronic engines to satisfy the NFPA 20 requirement for a redundant means of electronic fuel injection. Switching of the sensor inputs and outputs to the respective ECM is controlled through the FPDP either manually (by means of the ECM A/B Selector Switch on the panel) or through an automated process called Autoswitching (refer to the Operation section of this manual for more information on Autoswitching).

**NOTE:** *Cummins electronically-controlled “engines” normally enable ECMs with derate and shutdown protection. Fire pump drive engines have the derates and shutdowns disabled. Fire pump drive engines will run to destruction, making preventive maintenance even more essential for a fire pump drive engine.*

---

## 2.8 Digital panel expansion module (DPEM) (optional)

The digital panel expansion module (DPEM) is an optional electronic device that works in conjunction with the FPDP to provide options for monitoring and alarming custom inputs. As shown in [Figure 2-17](#), the DPEM is housed in a 316 stainless steel enclosure and contains a series of terminal blocks for customer connection to specified alarm points. One DPEM can be configured for any or all of the following:

- Four switched inputs;
- Three temperature inputs;
- One exhaust temperature input;
- Six pressure inputs; and/or
- J1939 parameters (when applicable).

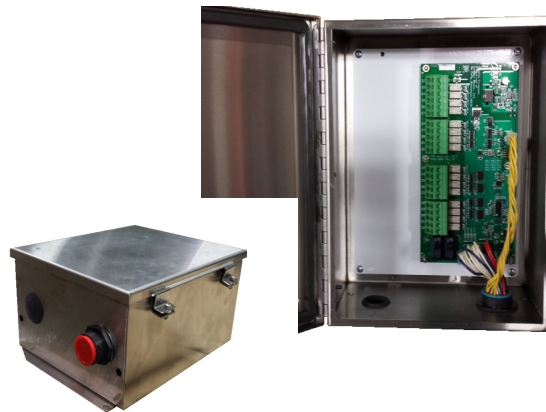

Figure 2-17 Digital programming expansion module (DPEM)

## 2.9 Fuel supply and drain

As shown in [Figure 2-2](#), the fuel supply and return connections are centrally located on the side. Refer to the [Engine Data Sheet](#) for the maximum allowable fuel tank supply locations above the fuel pump. Follow published troubleshooting procedures to check fuel restriction measurements.

## 2.10 High pressure common rail (HPCR) fuel system

The fire pump drive engine is equipped with an electronic fuel system that delivers precise fuel quantities with precise injection timing at injection pressures up to 24,000 psi (1600 BAR). The system consists of a high pressure pump that supplies a common fuel rail and accumulator manifold, feeding high-pressure electronic controlled injectors which provide precise fuel metering and timing. The system is controlled by the ECM for fueling and timing based on temperature, altitude, pressure, and throttle position.

**CAUTION**

***With the HPCR fuel system, manually priming the fuel system is not required and should not be performed.***

## 2.11 Air intake system

The air intake system supplies combustion air to the fire pump drive engine cylinders. The air filters prevent particulate matter from entering the air intake. [Figure 2-18](#) shows how the combustion air is drawn into the system. The turbocharger directs the air through the Charge Air Cooler (CAC) heat exchanger for cooling before entering the cylinders.

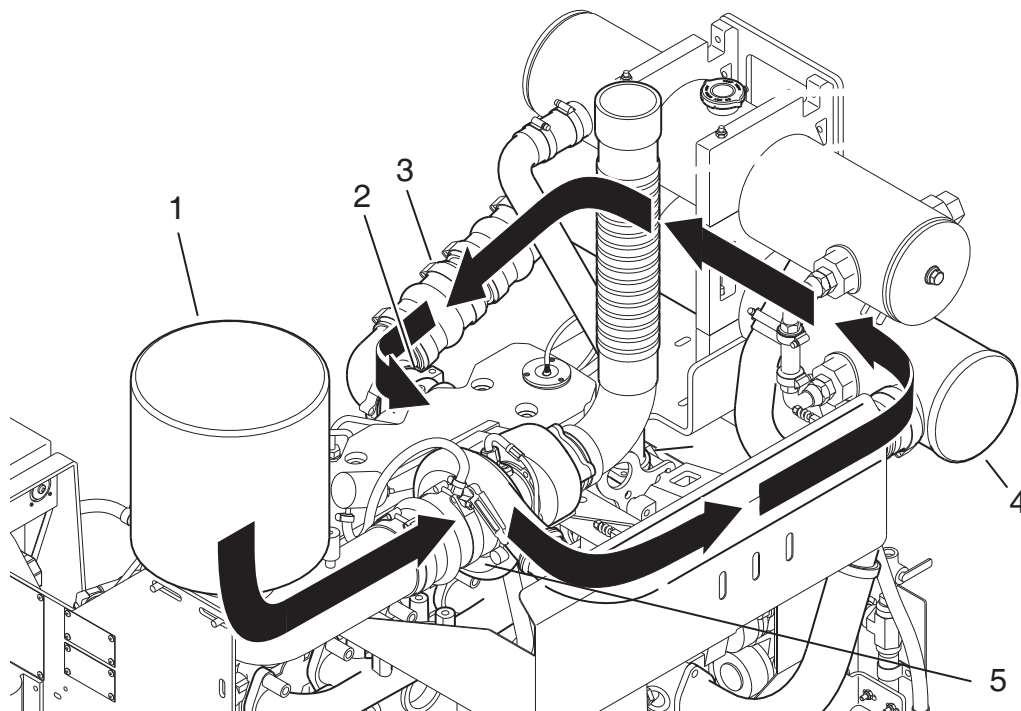

1. Air cleaner assembly (intake)
2. Intake manifold
3. Charge air cooler (CAC) hose
4. CAC heat exchanger
5. Turbocharger

**Figure 2-18 Engine air intake and Charge Air Cooling flow diagram (typical)**



## 2.12 Cooling water system

The following diagrams illustrate a typical cooling loop and the path of water through the engine cooling system. Water entering the cooling system through the cooling water inlet first circulates through the CAC heat exchanger, cooling the compressed air from the turbocharger outlet ducting. The cooled combustion air exits the CAC outlet duct to the engine air intake manifold. The cooling water from the CAC heat exchanger then passes through the engine coolant heat exchanger. The cooling water exits the coolant heat exchanger through a discharge connection.

**IMPORTANT:** *The cooling water supply must be immediately available when the engine is started.*

**IMPORTANT:** *Do not operate without a pressure cap.*

**NOTE:** *When filling with coolant, allow air to bubble out after the initial fill and then add coolant to the maximum level again. Monitor the coolant level after running the engine to ensure that all of the air is out of the system and replace with coolant.*

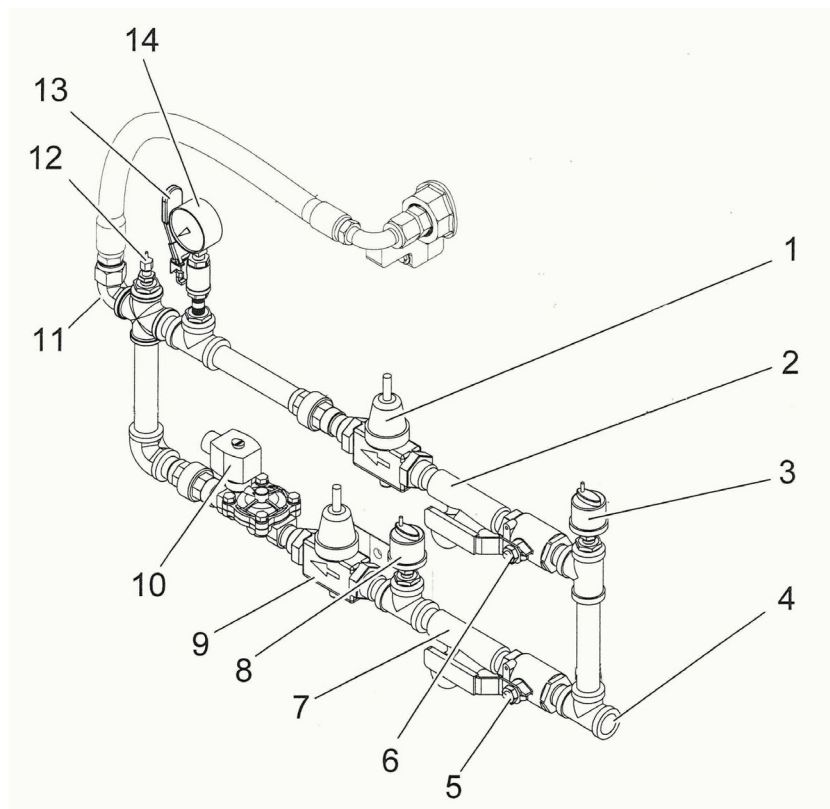

- |                                    |  |
|------------------------------------|--|
| 1. Bypass water pressure regulator | 9. Normal water pressure regulator               |
| 2. Bypass water strainer           | 10. Normal water solenoid valve (where required) |
| 3. Pre-strainer pressure sensor    | 11. Outlet to heat exchanger                     |
| 4. Raw water inlet connection      | 12. Temperature sensor                           |
| 5. Normal water inlet valve        | 13. Pressure gauge isolation valve               |
| 6. Bypass water inlet valve        | 14. Water supply pressure gauge                  |
| 7. Normal water strainer           |  |
| 8. Post strainer pressure sensor   |  |

**Figure 2-19 Cooling loop (typical)**

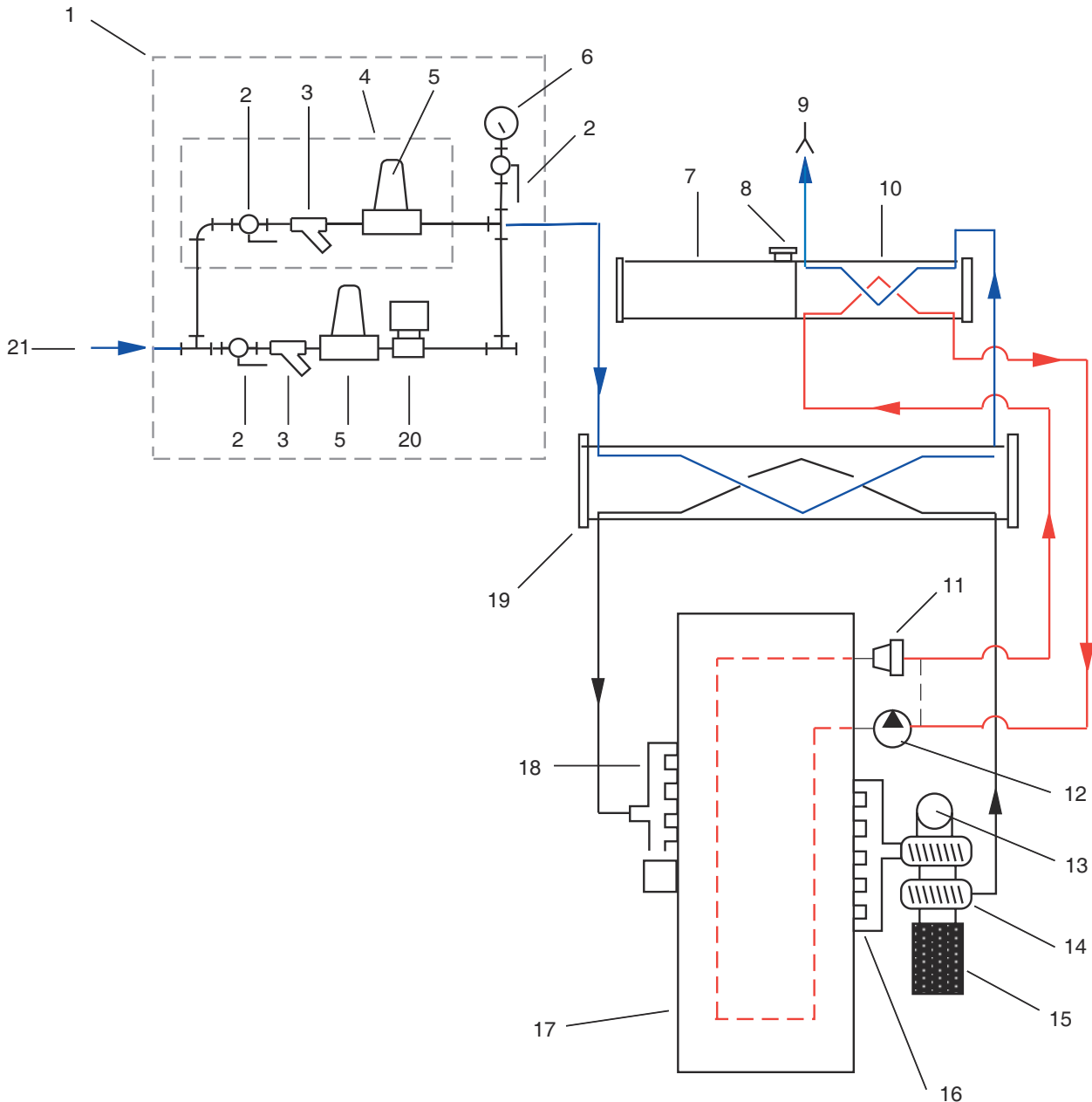

- |                                     |  |
|-------------------------------------|--|
| 1. Cooling loop                     | 12. Coolant pump                           |
| 2. Manual shut-off valve (3)        | 13. Exhaust flex connection                |
| 3. Raw water strainer (2)           | 14. Turbocharger                           |
| 4. Raw water bypass piping          | 15. Air filter                             |
| 5. Raw water pressure regulator (2) | 16. Exhaust manifold                       |
| 6. Raw water pressure gauge         | 17. Engine block                           |
| 7. Coolant expansion tank           | 18. Air intake manifold                    |
| 8. Coolant pressure/fill cap        | 19. Charge air cooler (CAC) heat exchanger |
| 9. Raw water discharge connection   | 20. Raw water solenoid valve (if required) |
| 10. Coolant heat exchanger          | 21. Raw water inlet connection             |
| 11. Thermostat                      |  |

**Figure 2-20 Engine cooling system flow diagram (typical)**

---

### 2.13 Engine oil system

The engine oil system lubricates moving internal engine parts (pistons, connecting rods, valves, cam shafts, shafts, and bearings). The oil pump circulates oil from the oil pan, through the oil filter, and into engine areas where friction may develop. Refer to the Cummins engine Operation and Maintenance Manual or Cummins QuickServe Online (QSOL) for additional information.

**NOTE:** *Typically engine oil has been added during manufacture and testing procedures; however, shipping restrictions can affect whether the oil is maintained in the engine or drained for shipping. Check the oil level at the dipstick. Add oil as necessary to bring the oil level to the H (high) mark on the dipstick.*

### 2.14 Engine exhaust system

The exhaust system removes engine exhaust from the cylinders after the combustion process. The exhaust discharges from the exhaust manifold, passes through (drives) the turbocharger, and exits through the exhaust connection. Refer to the Cummins engine Operation and Maintenance Manual or Cummins QuickServe Online (QSOL) for additional information.

This page is intentionally left blank.

# 3 - Installation

## 3.1 Introduction

This section provides instructions for the initial installation, adjustment, and testing of the Cummins fire pump drive engine. Appropriate portions of this section should be used when returning the engine to operation after overhaul or major maintenance.

## 3.2 Receiving and handling

Cummins fire pump drive engines are pre-assembled and tested before shipment. Parts not shipped attached to the engine are sometimes shipped individually. The equipment was thoroughly inspected and prepared for shipping before it was turned over to the carrier. Upon receipt of the fire pump drive engine from the shipper:

1. Inspect the equipment for damage that may have occurred in shipping; and
2. Check each item carefully against the shipping manifest or bill of lading.

## 3.3 Site preparation

The site should be clean and relatively level. Clear the proposed equipment area of overhanging obstructions and obstacles protruding from the floor.



***Avoid installation in a dusty or dirty environment. Provide adequate physical protection from other physical damage as may be present in the specific location.***

## 3.4 Drive shaft installation

Drive shaft installation should be done by trained technicians familiar with local, state, and federal codes and regulations.

Refer to National Fire Protection Association (NFPA) 20 for installation and applicable local code requirements and NFPA 25 for inspection, testing, and maintenance requirements.

Follow these steps to install the drive shaft:



***Ensure that the lifting device is capable of safely lifting the weight of the engine or the combined weight of the assembled pump base, drive line, and pump. Do not use the engine lifting points for assembly!***

1. Ensure that the engine and pump are correctly aligned.
  - a. Ensure that the engine position is centered on the frame side to side within  $\pm .76$  mm (.03 in) by measuring outside of the frame side to the engine support leg mounting pad. (Compare the two front engine supports and two back engine supports.)

- b. As shown in [Figure 3-1](#), align the engine center line to the pump center line within  $\pm .76 \text{ mm}$  (.03 in).

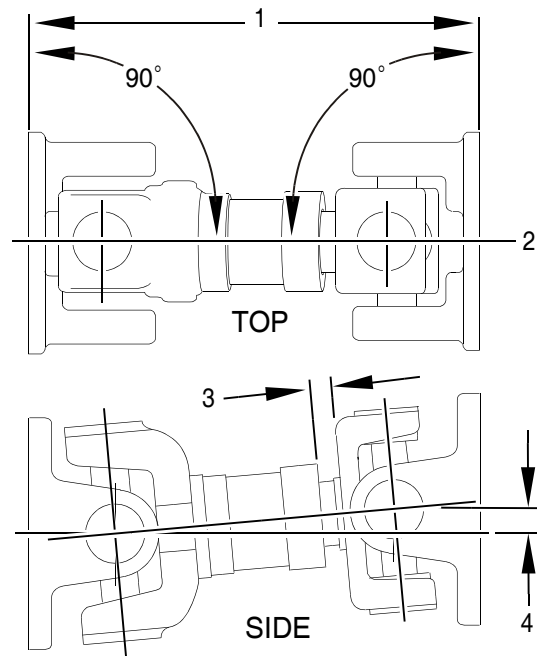

1. Planes must be parallel
2. Align both mounting center lines to  $\pm .76 \text{ mm}$  (.03 in)
3. Distance to equal half of total travel
4.  $2^\circ \pm 1^\circ$

**Figure 3-1 Drive shaft alignment**

- c. Ensure that the pump center line to the engine crankshaft center line (in vertical plane) is  $2^\circ \pm 1^\circ$ .
  - d. Ensure that the drive shaft mounting flanges are parallel.
2. As illustrated in [Figure 3-2](#), lubricate the grease fittings on the drive shaft universal joint.

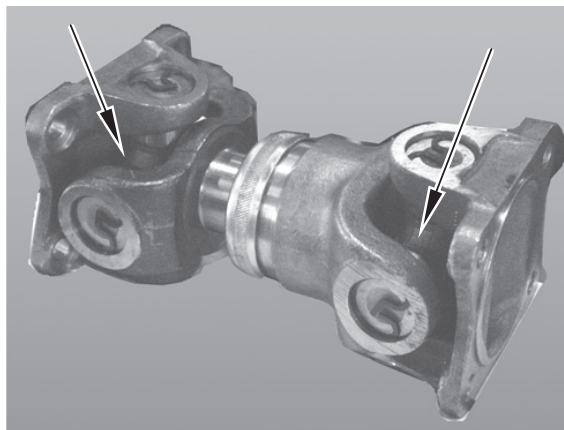

**Figure 3-2 Drive shaft universal joint grease fittings**

3. Check that the fire pump drive engine is properly installed per the pump manufacturer's specifications.
4. Cummins recommends using a good quality semi-synthetic, molybdenum-fortified National Lubricating Grease Institute (NLGI) #2 lithium complex grease.

**NOTE:** *Some lubrication loss may occur during transport and storage. It is recommended that the drive shaft be re-lubricated upon installation.*

### 3.5 Fuel supply installation

**NOTE:** *It is the responsibility of the customer to provide and install a properly-rated fuel tank per NFPA 20 guidelines.*

To properly install a fuel supply, follow these instructions:

1. Install an elevated no. 2 diesel fuel tank or other fuel supply arrangement which is compatible with American Society of Testing and Materials (ASTM) no. 2 diesel fuel specifications.

**NOTE:** *The fuel supply line at the fuel tank must be higher than the fuel intake port on the engine fuel pump. Ensure that the fuel system is installed in a safe and effective manner.*

2. Size the fuel tank for the maximum expected full-load engine operation period with the initial fuel level at the minimum level for refueling.
3. Install a fuel return line and route this line to the bottom of the fuel tank in order to minimize the return head.
4. Install a fuel supply line to the fire pump drive engine.

**NOTE:** *For fuel line specifications, refer to the [Engine Data Sheet](#).*

**NOTE:** *DO NOT use copper or galvanized pipe for the fuel return or supply lines.*

The fire pump drive engine fuel system has been primed during manufacturing and test procedures. The engine is equipped with an engine driven (gear) fuel pump.

An optional fuel pre-filter and a fuel filter/water separator is integrated into the fuel delivery system of the fire pump drive engine. To ensure that the filter/separator is free of water, open the fuel filter/water separator drain at the bottom of the filter and drain the fuel into a container until no water is present. Dispose of the contaminated fuel in accordance with local environmental regulations.

#### **CAUTION**

***Due to the precise tolerances of diesel injection systems, it is extremely important that the fuel be kept clean and free of dirt or water. Dirt or water in the system can cause severe damage to both the fuel pump and the fuel injectors.***

#### **WARNING**

***Do not mix gasoline, alcohol, gasohol, ethanol, or methanol with diesel fuel. This mixture will cause severe engine damage or explosion.***

#### **CAUTION**

***Use ONLY no. 2 diesel (ASTM no. 2D) fuel. Any fuel other than no. 2 diesel fuel may affect emission levels. Any adjustment to compensate for reduced performance with a fuel system using alternate fuel is not warrantable.***

### 3.6 Cooling water supply installation

**IMPORTANT:** *The cooling water supply must be immediately available when the engine is started. Ensure that the supply line valves are in the OPEN position.*

**NOTE:** *The flow rate of the cooling water should be as great as possible without exceeding the maximum allowable pressure shown in the [Engine Data Sheet](#).*

To install the cooling water supply:

1. Provide a cooling water discharge line at the outlet of the engine coolant heat exchanger and provide a cooling water supply line to the cooling water inlet per the [Engine Data Sheet](#).

**NOTE:** *The cooling water outlet piping from the heat exchanger should be one pipe size larger than the supply piping.*

2. Check the pressure regulator setting on the cooling loop with water flowing through the heat exchanger. The cooling loop is supplied by Cummins; both water pressure regulators have been set at (or slightly less) water pressure during manufacture and testing:
  - For the CFP5E, CFP7E, CFP9E, CFP15E and CFP23E - 276 kPa (40 psi)
  - For the CFP30E, CFP50 and CFP60E models - 345 kPa (50 psi).

**IMPORTANT:** *The manual water valves for the normal loop should remain OPEN at ALL times. The manual valves for the bypass loop should be CLOSED during automatic (pump controller) operation. When running, the engine should stabilize between temperatures identified on the [Engine Data Sheet](#). The flow rate may need to be adjusted to maintain the desired engine temperature.*

**NOTE:** *Excessively cold (4 °C to 23 °C [40 °F to 75 °F]) cooling water flow can cause condensation inside the charge air cooler.*

**IMPORTANT:** *Continuous operation with low coolant temperature (below 70 °C [158 °F]) or high coolant temperature (above 107 °C [225 °F]) can damage the engine.*

3. Adjust the cooling water based on the water *flow* rather than the water *pressure*. The flow is dependent on the cooling water temperature. Refer to the [Engine Data Sheet](#).
4. To measure the water flow, use an appropriate-sized container to measure the amount of water and the elapsed time of the water to flow from the discharge pipe and then formulate the calculations:

Flow rate = container size/ time to fill container.

Example:

Time to fill a 20 gallon container = 15 seconds.

20 gallons divided by 15 seconds = 1.33 gallons per second.

Multiply by 60 seconds = 80 gallons per minute (gpm) (FLOW RATE)

5. Adjust both pressure regulators to a pressure that will provide a flow rate at or above the specifications listed in the [Engine Data Sheet](#).



**CAUTION**

**When the cooling water piping is installed, adjust both of the pressure regulator setpoints before operating the pump. Damage to the heat exchanger may occur from improperly regulated cooling water supply pressure.**

**IMPORTANT:** Monitor the oil pressure and coolant temperature gauges frequently. Refer to Lubricating Oil System Specifications or Cooling System Specifications in the [Engine Data Sheet](#) for recommended operating pressures and temperatures. Shut off the engine if any pressure or temperature does not meet the specifications.

**NOTE:** Maximum engine coolant temperature should not exceed the temperature listed on the [Engine Data Sheet](#). The coolant expansion pressure/fill cap must meet the minimum pressure of 10 kPa (15 psi).

The engine coolant system contains a mixture of at least 50% antifreeze and 50% water. The coolant level should be maintained so it is visible in the coolant level sight gauge.

### 3.7 Battery installation

The minimum recommended Society of Automotive Engineers (SAE) reserve capacity (RC) and SAE cold cranking ampere (CCA) values for a particular engine can be found on the [Engine Data Sheet](#). RC and CCA definitions can be found in SAE Standard J537. Refer to NFPA 20 and FM 1333 standards for additional battery installation information.

**WARNING**

**Battery electrolyte (sulfuric acid) is highly caustic and can burn clothing and skin. Wear impervious neoprene gloves and safety goggles, or a full face shield, when working with the batteries.**

**IMPORTANT:** Batteries must meet the requirement listed in the electrical system specifications. Batteries may be supplied by Cummins as an option, or may be supplied by the customer.

**WARNING**

**Batteries can emit explosive gases during charging. Always ventilate the compartment before servicing the batteries. To avoid arcing, remove the negative (-) battery cable first and attach the negative (-) battery cable last.**

To properly install the batteries:

1. As shown in the following diagrams, install the battery cable kit or equivalent customer-supplied wiring. Install battery sets in a well-ventilated or otherwise protected location.

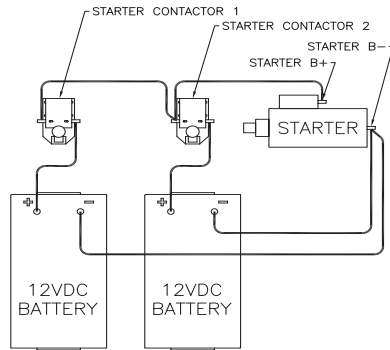

**Figure 3-3 Series battery connection 12 VDC**

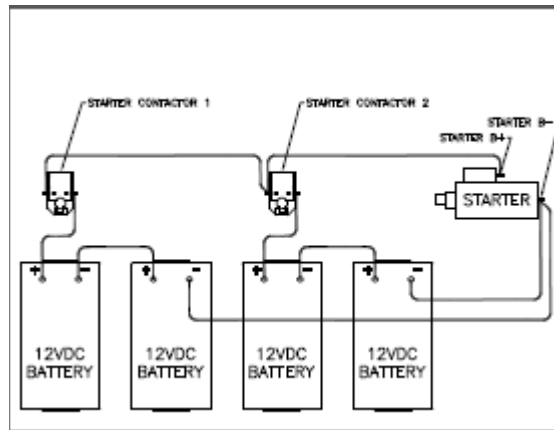
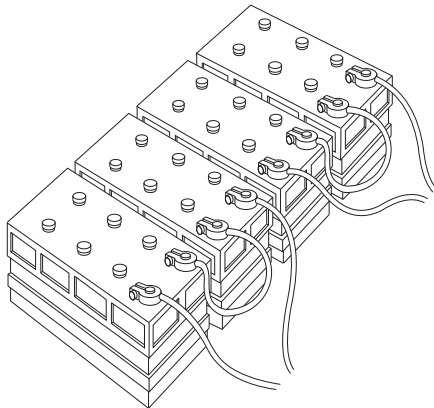

**Figure 3-4 Series battery connection 24 VDC**

- 
2. Provide adequate room for servicing or replacing the batteries. Provide protection from extremes of temperature and weather.
  3. Locate the batteries near the engine or increase the size of the conductors as required by applicable codes. Ensure that the batteries are configured properly for 12 or 24 (depending on the engine) VDC standard operations.
  4. Check the battery cables and connections.

**NOTE:** *Coat the terminals with petroleum jelly to prevent corrosion. Install the cables and tighten the battery connections.*

### 3.8 Signal and control installation

The fire pump controller wires must be connected to the terminal blocks (TBs) on the FPDP Interface Terminal Strip and on the Battery Charger Interface. To complete the signal and control installation:

1. Ensure that the fire pump controller is properly installed and configured per the manufacturer's instructions.
2. Complete the fire pump controller wiring (customer-supplied) per the manufacturer's instructions.
3. Ensure electrical continuity and adequate insulation resistance for the installed wiring. Refer to the Operation - Engine Setup Screen section to conduct a Terminal Block Test from the FPDP.

#### 3.8.1 FPDP interface terminal strip

As shown in [Figure 3-5](#), the TBs between the fire pump controller and the fire pump driver are standard UL and FM controller terminals and follow a direct one-to-one correspondence (some TBs are optional):

- **TB-1 [Run Solenoid Circuit]:** This B+ signal is necessary for fire pump operations while in the FPDP is in AUTO (automatic) mode. The Electronic Control Module (ECM) keyswitch/Fuel Shutoff (FSO) and raw water solenoid are activated when voltage is present at TB-1. When TB-1 is removed while the engine is running, the FPDP will command electronic engines to idle for up to three minutes.
- **TB-2 [Crank Termination Switch]:** This B+ signal is provided by the FPDP to inform the pump controller that the engine is running. Crank Termination indicates that the engine has started and that the crank command from the fire pump controller should stop immediately.
- **TB-3 [Overspeed Switch]:** This B+ signal is provided by the FPDP when the engine speed has exceeded 115% of the rated engine speed. When overspeed occurs, the ECM keyswitch or FSO outputs and the raw water cooling loop solenoid are immediately deactivated in an attempt to stop the fire pump drive engine. The FPDP will not allow the engine to be restarted until after the overspeed alarm has been reset.
- **TB-4 [Low Lubricant Pressure Switch]:** A ground path is provided by the FPDP when the oil pressure has dropped below the 16 psi (110 kPa) setpoint when the engine is running. A ground path is also provided to indicate low oil pressure when the engine is NOT running.

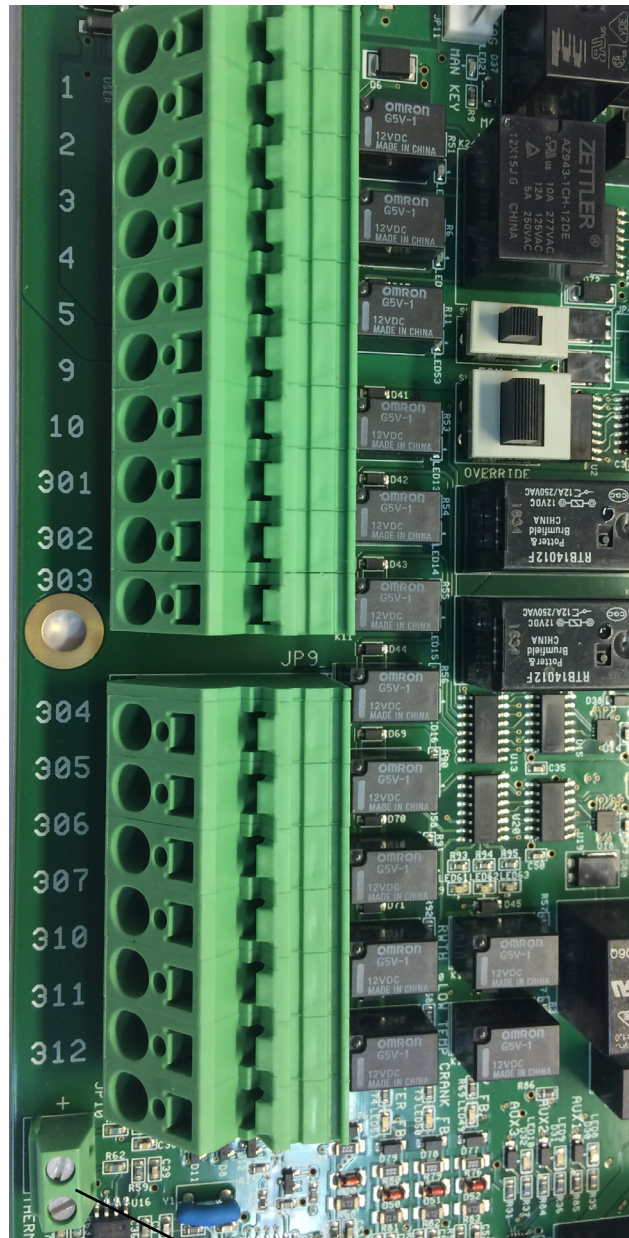

Thermocouple input

Figure 3-5 FPDP interface terminal strip

- **TB-5 [High Engine Temperature Signal]:** A ground path is present when the engine is running and the coolant temperature is at or above 212 °F (100 °C).
- **TB-9 [Main Battery Contactor One Coil or Battery Relay One Coil]:** This B+ signal is driven from the fire pump controller to contactor A when desiring to crank the engine from Battery A. Current in this circuit shall not exceed 10A continuous.

- 
- TB-10 [**Main Battery Contactor Two Coil or Battery Relay Two Coil**]: This B+ signal is driven from the fire pump controller to contactor B when desiring to crank the engine from Battery B. Current in this circuit shall not exceed 10A continuous.
  - TB-301 [**ECM Switch**]: A ground path is provided by the FPDP when the engine is operating on ECM B.
  - TB-302 [**Fuel Injection Malfunction (FIM)**]: A ground path is provided by the FPDP when either of the ECMs triggers a fault code which can affect the performance of the Fuel Injection System. See the Troubleshooting section for possible fault causes and solutions.
  - TB-303 [**ECM Warning**]: A ground path is provided by the FPDP when a single ECM has been diagnosed as failed.
  - TB-304 [**ECM Failure**]: A ground path is provided by the FPDP when both ECMs have been diagnosed as failed.
  - TB-305 [**Custom Output 1**]: A ground path is provided by the FPDP when the custom alarm is configured and activated.

**NOTE:** *If an Air Shutoff Valve is purchased, TB-305 is reserved for valve position feedback.*

- **Type K Thermocouple Input - optional:** The screws to the Type K thermal couple input may be loosened for installation of an exhaust temperature.
- TB-306 [**Custom Output 2**]: A ground path is provided by the FPDP when the custom alarm is configured and activated.
- TB-307 [**Custom Output 3**]: A ground path is provided by the FPDP when the custom alarm is configured and activated.
- TB-310 [**Raw Water High Inlet Temperature**] - *not applicable on radiator-cooled models* - A ground path is provided by the FPDP when high raw water temperature is sensed.
- TB-311 [**Clogged Raw Water Cooling Loop Strainer**] - *not applicable on radiator-cooled models* - A ground path is provided by the FPDP when the raw water supply restriction is sensed.
- TB-312 [**Low Engine Temperature Signal**]: A ground path is provided by the FPDP when the engine coolant falls below 100 °F (37.8 °C).

### 3.8.2 Battery charger interface

As shown in [Figure 3-6](#), the Battery Charger Interface provides power to the fire pump controller, as well as provides charging current to the fire pump drive engine batteries. The Battery Charger Interface includes:

- TB-6 [**Battery A Positive**]: The fire pump controller senses Battery A charge state and charges Battery A through TB-6.
- TB-8 [**Battery B Positive**]: The fire pump controller senses Battery B charge state and charges Battery B through TB-8.
- TB-11 [**Battery A and Battery B Negative**]: The fire pump controller uses TB-11 as a ground reference for incoming power, as well as to charge the fire pump drive engine batteries.

**NOTE:** *This is not intended to create a fully isolated battery negative or ground system. Current in each terminal block shall not exceed 30 amperes continuous.*

To complete the battery signal connections:

1. Provide the initial charge on the redundant batteries per the battery charger's instructions.
2. Check that both voltmeters on the FPDP indicate the approximate battery voltage.

**NOTE:** *Both sets of batteries can be used for starting the engine in the event that one set is low.*

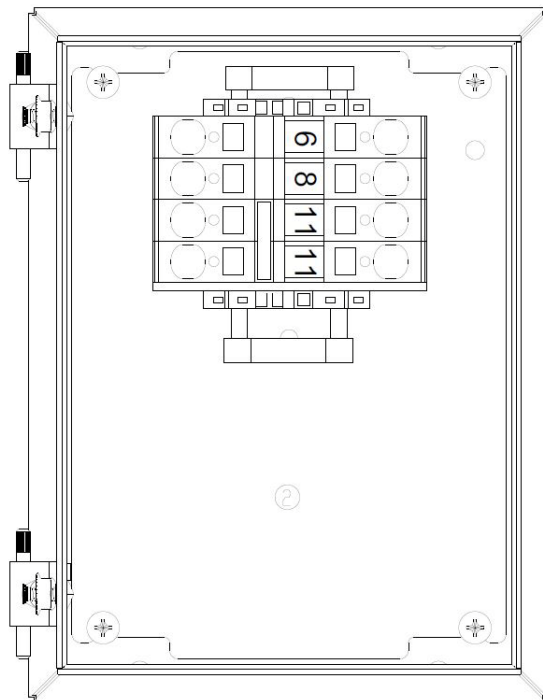

**Figure 3-6 Battery charger interface**

### 3.9 Coolant system preparation

The fire pump drive engine cooling and lubrication system was initially filled during manufacture and testing. To properly prepare the coolant system:

**CAUTION**

**Ensure that all coolant systems have been filled to the proper level before operation by checking the coolant level sight gauge on the surge tank.**

1. Inspect the engine coolant hoses and hose clamps and ensure that all coolant hoses and clamps are properly installed and water tight.
2. Ensure that the engine coolant heater maintains an engine coolant temperature of 49 °C (120 °F) or above.
3. Ensure that coolant is present in the engine coolant heater before plugging the heater element into a dedicated circuit. Add coolant, if necessary.

- 
4. Inspect the heat exchanger weekly for external damage and contamination.

**NOTE:** Contamination of the heat exchanger will affect the ability of the cooling system to transfer heat and properly cool the engine and intake manifold.

5. Add coolant, if necessary:

**NOTE:** Supplemental engine coolant should be a mixture of 50% ethylene glycol antifreeze and 50% water to avoid engine damage. For additional information, refer to the antifreeze information found in the Maintenance section.

- If the engine *IS* equipped with a sight level gauge, ensure that the engine coolant level is visible at the center of the sight level gauge. Add coolant as required. **DO NOT OVERFILL!**
- If the engine *IS NOT* equipped with a sight level gauge, fill the cooling system with coolant to the bottom of the fill neck. Do not fill above the bottom of the fill neck.

6. Re-install the pressure/fill cap.

**▲ WARNING**

**Do not remove the pressure/fill cap from a hot engine. Wait until the coolant temperature is below 50 °C (122 °F) before removing the pressure/fill cap. Heated coolant spray or steam can cause personal injury.**

### 3.10 Charge air cooler (CAC) inspection

The charge air cooler (CAC) system reduces the temperature of the compressed combustion air from the turbocharger before entering the air intake manifold.

Inspect the CAC piping and hoses for loose/missing hose clamps, hose punctures, leaking manifold seals, or corrosion. Torque the hose clamps to the recommended torque value. Refer to the Engine Specification Sheet.

### 3.11 Lubricating oil system preparation

The fire pump drive engine and turbocharger were initially lubricated during manufacture and testing. To prepare the lubricating oil system for operation:

1. Check the oil level using the dip stick before operating the fire pump drive engine.
2. Fill the oil fill port to the “H” mark on the dipstick with lubricating oil.

For those models (CFP9E, CFP11E, CFP15E, and CFP23E) equipped with an oil level gauge, it may be necessary to adjust the gauge:

1. Ensure the engine oil is at the low level of the oil dipstick.
2. Start the engine.
3. Adjust the oil level gauge until it alarms.
4. Stop the engine.
5. Fill the oil fill port to the “H” mark on the dipstick with lubricating oil.



**NOTE:** Do not use special “break-in” lubricating oils for new or rebuilt Cummins engines. Use the same type of oil during the “break-in” as used during normal operation.

**CAUTION**

**Some regulatory and shipping restrictions may require that all lubricants, fuels, and coolants be drained for transport. Ensure that all cooling and lubrication systems have been filled to the proper level before operation.**

**NOTE:** Using multi-viscosity lubricating oil can improve oil consumption control and improve engine cranking in cold temperatures while maintaining lubrication at high operating temperatures. Cummins recommends Premium Blue® 15W-40 oil for most climates.

**CAUTION**

**Ensure that all cooling and lubrication systems have been filled to the proper level before operation.**

### 3.12 Variable Speed Pressure Limiting Control (VSPLC) preparation

**NOTE:** VSPLC capability is on electronic engines, only. This section is not applicable to mechanical engines.

As shown in [Figure 3-7](#), to prepare the fire pump drive engine for VSPLC capability, connect a 1/2 inch (12.7 mm) inside diameter pressure sensing line to the transducer or Cummins-supplied flexible hose located under the FPDP and the other end to between the pump discharge flange and the discharge check valve.

**IMPORTANT:** Cummins recommends that provisions be made within the VSPLC connection line to account for any engine vibration and movement.

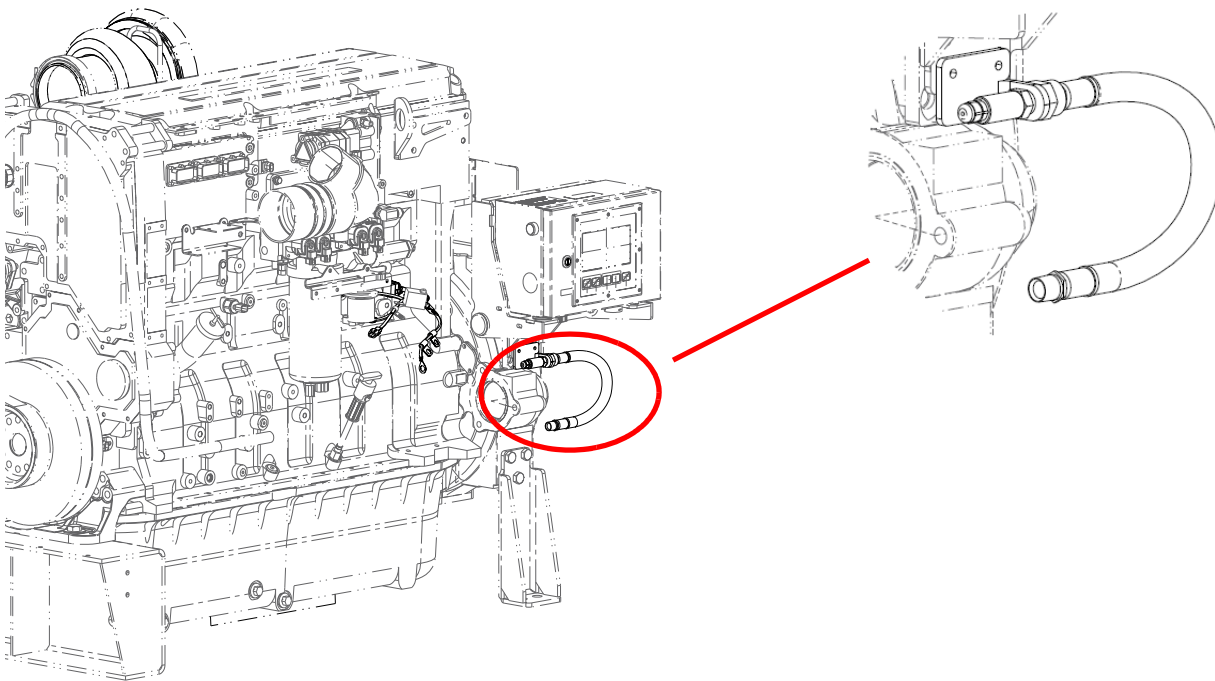

**Figure 3-7 VSPLC pressure sensing connection**



---

### 3.13 Pre-start inspections

Prior to starting the fire pump drive engine for the first time, perform a visual inspection:

1. Check that there is no apparent damage and that all components are installed.
2. Check that the drive belt is properly installed.
3. Check that all hoses and tubes are properly installed.
4. Check that all electrical connections are properly installed.
5. Check that the fire pump drive engine is properly installed per the pump manufacturer's instructions, is correctly aligned, and is free to rotate.
6. Lubricate the grease fittings on the auxiliary drive shaft.

**NOTE:** Use the same type of oil as used in normal operation. Cummins recommends Premium Blue<sup>®</sup> 15W-40 oil for most climates.

**▲ WARNING**

**Before operating the equipment, complete all safety checks, remove all tools and foreign objects from the equipment, and ensure that all guards are in place and securely fastened. Alert area personnel that the equipment will be starting. Unintentional equipment start-up or contact with exposed or moving components can cause personal injury or equipment damage.**

### 3.14 Engine monitoring

When the engine starts, it is important to monitor the displays:

1. Immediately check that water flow is established through the coolant heat exchanger. The water flow should be established immediately, but some delay may occur before the flow exits the heat exchanger drain connection.

**NOTE:** Ensure that cooling water is flowing and the water pressure shown on the local pressure gauge is no more than 414 kPa (60 psi). The minimum cooling water flow rate is identified in the [Engine Data Sheet](#).

2. Ensure that the engine operating temperature stabilizes between applicable ranges as identified in the [Engine Data Sheet](#).
3. Operate the engine for eight to ten minutes.
4. Inspect the engine for leaks, unusual noises, or other indications of incorrect operation.
5. While running the engine, look for the following signals during operation and field testing:

**▲ CAUTION**

**If the oil pressure is not displayed on the gauge or if the low oil pressure message is displayed within fifteen seconds, STOP THE ENGINE IMMEDIATELY! Continued operation without proper lubrication will cause engine damage.**

- Low engine lubricant pressure
- High engine coolant temperature

- Low engine temperature
  - High raw water temperature
6. Shut off the engine by pressing and holding the overspeed **RESET/STOP** switch.
  7. Shortly after the engine stops, check that the water flow stops automatically.
  8. Correct any problems found during the inspection before proceeding.
  9. Check the engine lubricating oil level at the dip stick. Add oil, if necessary.
  10. Check the coolant expansion tank level. Add coolant, if necessary.
  11. Check the cooling water strainers. Clean the strainers according to the maintenance schedule in [Section 5 - Maintenance](#).
  12. Perform engine speed control and safety system tests per the instructions in [4 - Operation](#).

### 3.15 Start-up validation

The required installation tests are outlined in the NFPA 20 Standards and shall be performed to validate automatic and manual operational requirements for field acceptance testing. Visit <https://www.cummins.com/engines/fire-pump-drives/registration-and-warranty> to download the Start-up inspection checklist.

**NOTE:** *The maximum engine speed should only be altered by a Cummins technician.*

These instructions should be used during the commissioning of a new diesel fire pump drive engine to validate the alarming between the Cummins FPDP and the pump controller. The various testing techniques detailed below will safely validate the connections between these two devices, the pump controller's response to the alarm, and the FPDP's internal ability to activate the alarm. Unless otherwise instructed, conduct all tests with the FPDP in **Auto** mode and the pump controller in **Manual** mode. The tests apply to both Electronic Control Module (ECM) A and ECM B

To access the Analog Values screen, press **MENU** and then **ANALOG VALUES**. If an alarm does not register on the pump controller as expected, refer to the Troubleshooting instructions at the end of this document.

VSPLC units must be exercised to create their maximum pressure during commissioning. This can be easily completed by switching the unit into **Manual** mode on the FPDP. A dialog box will appear on the screen alerting the user that the engine will run at a constant rated speed. Once in **Manual** mode, simply start the engine from the FPDP, and the engine will run at its rated maximum speed. **NOTE: TB-1 must be inactive for the engine to run at a constant rated speed, otherwise it will run in VSPLC mode.**

To access the **Terminal Block Test** menu to test the Power Board circuitry and connection to the pump controller:

1. Press MENU



2. Select ENGINE SETUP

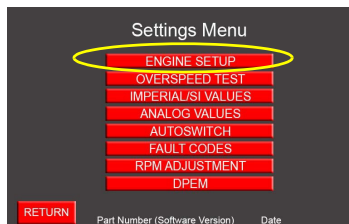

3. Enter "806" and press SUBMIT

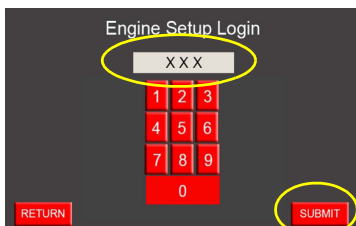

4. Select TERMINAL BLOCKS

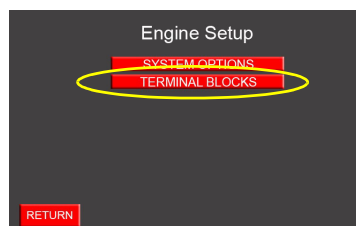

A typical Terminal Block Test screen is shown below. Follow the detailed instructions in the next section to perform the start-up validation.

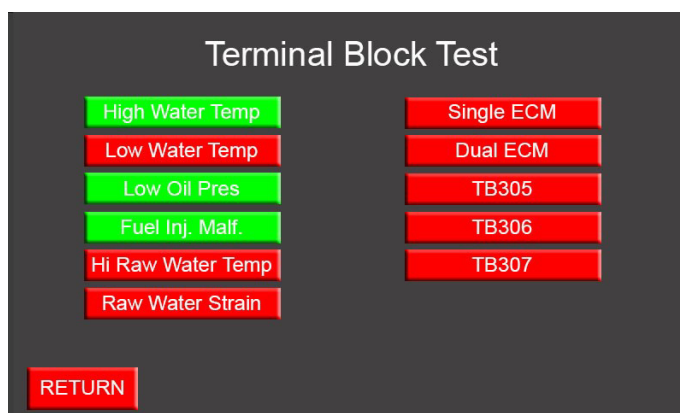

**Figure 3-8 Typical Terminal Block Test screen**

### 3.15.1 High Water Temp

Simulate a high coolant temperature condition (TB-5 - High Engine Temperature).

TEST	With the engine running from the pump controller and the FPDP in <b>Auto</b> mode, press the <b>High Water Temp</b> soft key (when the button is green, the alarm will activate) to simulate a high coolant temperature alarm sent from the FPDP to the pump controller.		
	Validate that the high coolant temperature alarm is active (LED is lit) on the pump controller.	VERIFY	The pump controller alarm indicates that a high engine temperature condition has occurred.
	After the alarm has been verified, reset the alarm on the pump controller by turning the pump controller off and then on.		

### 3.15.2 Low Water Temp

Simulate a low engine temperature condition (TB-312 – Low Engine Temperature).

**NOTE:** *The LOW ENGINE TEMPERATURE alarm can be conveniently tested while the engine is cold using the Primary Method. If the engine is warm, use the Alternate Method.*

**Primary** Method (If engine is cold)

TEST	Start and run the engine from the pump controller.		
	During the first few minutes of engine operation while the <b>Water Temp</b> (shown on the <b>Analog Values</b> screen) is less than 110 °F, the low engine temperature alarm should be active on the pump controller.	VERIFY	The pump controller alarm indicates that a low engine temperature condition has occurred.

**Alternate** Method (If engine is warm) - simulation from the Terminal Block Test screen

TEST	With the engine running from the pump controller and the FPDP in <b>Auto</b> mode, press the <b>Low Water Temp</b> soft key (when the button is green, the alarm will activate) to simulate a low engine temperature alarm sent from the FPDP to the pump controller.		
	Validate that the low engine temperature alarm is active (LED is lit) on the pump controller.	VERIFY	The pump controller alarm indicates that a low engine temperature condition has occurred.
	After the alarm has been verified, reset the alarm on the pump controller by turning the pump controller off and then on.		

### 3.15.3 Low Oil Pres

Simulate a low engine temperature condition (TB-4 – Low Oil Pressure).

TEST	With the engine running from the pump controller and the FPDP in <b>Auto</b> mode, press the <b>Low Oil Pres</b> soft key (when the button is green, the alarm will activate) to simulate a low oil pressure alarm sent from the FPDP to the pump controller.		
	Validate that the low oil pressure alarm is active (LED is lit) on the pump controller.	VERIFY	The pump controller alarm indicates that a low oil pressure condition has occurred.
	After the alarm has been verified, reset the alarm on the pump controller by turning the pump controller off and then on.		

### 3.15.4 Fuel Inj. Malf.

Simulate a fuel injection malfunction (TB-302 - Fuel Injection Malfunction (FIM)).

TEST	With the engine running from the pump controller and the FPDP in <b>Auto</b> mode, press the <b>Fuel Inj. Malf.</b> soft key (when the button is green, the alarm will activate) to simulate a fuel injection malfunction alarm sent from the FPDP to the pump controller.		
	Validate that the fuel injection malfunction alarm is active (LED is lit) on the pump controller.	VERIFY	The pump controller alarm indicates that a fuel injection malfunction condition has occurred.
	After the alarm has been verified, reset the alarm on the pump controller by turning the pump controller off and then on.		

### 3.15.5 Hi Raw Water Temp

Simulate a high raw water temperature alarm sent from the FPDP to the pump controller (TB-310 - Raw Water High Inlet Temperature).

**NOTE:** *The Raw Water Temperature High alarm can be validated in two different ways. The first way allows for a more thorough evaluation of the system.*

**Primary Method - Grounding the Sender**

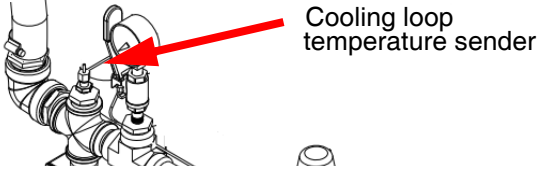
TEST	With the engine running from the pump controller and the FPDP in <b>Auto</b> mode, ground the raw water temperature sender by creating continuity between the sender terminal and the bare metal on the raw water cooling loop.	VERIFY	
	With the sensor grounded, the FPDP will display a high <b>Cooling Loop Temp</b> (shown on the <b>Analog Values</b> screen) and the high raw water temperature alarm should be active on the pump controller.		

**Alternate Method - simulation from the Terminal Block Test screen**

TEST	With the engine running from the pump controller and the FPDP in <b>Auto</b> mode, press the <b>Hi Raw Water Temp</b> soft key (when the button is green, the alarm will activate) to simulate a high raw water temperature alarm sent from the FPDP to the pump controller.	VERIFY	The pump controller alarm indicates that a high raw water temperature condition has occurred.
	Validate that the high raw water temperature alarm is active (LED is lit) on the pump controller.		
	After the alarm has been verified, reset the alarm on the pump controller by turning the pump controller off and then on.		

### 3.15.6 Raw Water Strain

Simulate a low raw water flow alarm sent from the FPDP to the pump controller (TB-311 - Clogged Raw Water Cooling Loop Strainer).

**NOTE:** This alarm can be validated in two different ways. The first way allows for a more thorough evaluation of the system.

**Primary** Method - close the raw water cooling loop primary manual shutoff valve

TEST	Begin with the engine running from the pump controller and the FPDP in <b>Auto</b> mode.	VERIFY	The pump controller alarm indicates that a low raw water flow condition has occurred.
	Simulate a clogged raw water strainer by throttling (partially closing) the raw water cooling loop Primary Manual Shutoff Valve.		
	With the valve partially closed, the FPDP will display a high <b>Diff Press Post:</b> (shown on the <b>Analog Values</b> screen) and the low raw water flow alarm should be active on the pump controller.		
	After the alarm has been verified, re-open the raw water cooling loop Primary Manual Shutoff Valve and reset the alarm on the pump controller by turning the pump controller off and then on.		

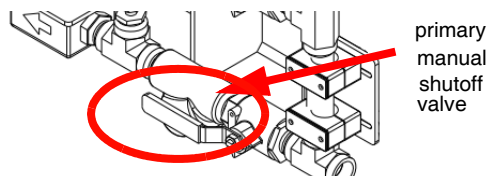

**Alternate** Method - simulation from the Terminal Block Test screen

TEST	With the engine running from the pump controller and the FPDP in <b>Auto</b> mode, press the <b>Raw Water Strain</b> soft key (when the button is green, the alarm will activate) to simulate a low raw water flow alarm sent from the FPDP to the pump controller.	VERIFY	The pump controller alarm indicates that a low raw water flow condition has occurred.
	Validate that the low raw water flow alarm is active (LED is lit) on the pump controller.		
	After the alarm has been verified, reset the alarm on the pump controller by turning the pump controller off and then on.		

**3.15.7 TB-303/304 - ECM Warning/ECM Failure**

**NOTE:** *Single ECM Warning and ECM Failure can be conveniently tested while the engine is off using the primary method. If the engine is running, use the alternate method, although this will not activate the autoswitch routine.*

**Primary** Method (engine off)

TEST	With the engine off, place the pump controller in <b>Manual</b> or <b>Test</b> mode and the FPDP in <b>Auto</b> mode.		
	<p>Press and hold the <b>Engine Stop</b> button on the upper left side of the FPDP. This will manually cut switched power to the ECMs.</p> <p>The FPDP will detect the loss of data link communications from the ECM and report an ECM failure to the pump controller.</p> <p>The FPDP <b>ECM A/ECM B</b> button will automatically switch from <b>ECM A</b> to <b>ECM B</b> (the LED will switch from <b>ECMA</b> to <b>ECMB</b>).</p> <p>Note: Once the FPDP switches to <b>ECM B</b>, the ECM failure alarm should become active.</p>	VERIFY	The pump controller alarm indicates that an ECM failure condition has occurred.
	With the <b>Engine Stop</b> button still held, the FPDP will diagnose a failure of the alternate ECM. The ECM failure alarm should be activated on the pump controller.	VERIFY	The pump controller alarm indicates that an ECM failure (for ECM B) condition has occurred.

**NOTE:** *Repeat this test by starting with ECM B active and then allowing the FPDP to transition from ECM B to ECM A during the autoswitch routine.*

**Alternate** Method on next page



**Alternate** Method (engine running) - simulation from the Terminal Block Test screen

TEST	With the engine running from the pump controller and the FPDP in <b>Auto</b> mode (the FPDP <b>ECM A / ECM B</b> button should indicate <b>ECM A</b> ), press the <b>Single ECM</b> soft key (when the button is green, the alarm will activate) to simulate an ECM failure alarm sent from the FPDP to the pump controller.	VERIFY	
	Validate that the ECM failure alarm is active (LED is lit) on the pump controller. The FPDP <b>ECM A / ECM B</b> button will automatically switch from <b>ECM A</b> to <b>ECM B</b> (the LED will switch from <b>ECMA</b> to <b>ECMB</b> ). Note: Once the FPDP switches to <b>ECM B</b> , the TB301 alarm should become active.		
	Press the <b>Dual ECM</b> soft key (when the button is green, the alarm will activate) to simulate an ECM failure alarm (for ECM B) sent from the FPDP to the pump controller.	VERIFY	
	After the alarm has been verified, reset the alarm on the pump controller by turning the pump controller off and then on.		

**NOTE:** Repeat this test by starting with ECM B active and then allowing the FPDP to transition from ECM B to ECM A during the autoswitch routine.

**3.15.8 TB-305-307 - Custom Outputs - simulation from the Terminal Block Test screen**

**NOTE:** Not every engine will have custom switched inputs available for testing, use this section as required only.

TEST	With the engine running from the pump controller and the FPDP in <b>Auto</b> mode, press the applicable <b>TB305</b> , <b>TB306</b> , or <b>TB307</b> soft key (when the button is green, the alarm will activate) to simulate an applicable <b>custom</b> alarm sent from the FPDP to the pump controller.	VERIFY	
	Validate that the custom alarm is active (LED is lit) on the pump controller.		
	After the alarm has been verified, reset the alarm on the pump controller by turning the pump controller off and then on.		

**3.15.9 TB-301 - ECM Switch**

TEST	With the engine off and <b>ECM A</b> active, press the <b>ECM A / ECM B</b> button one time to switch to <b>ECM B</b> (the LED will switch from <b>ECMA</b> to <b>ECMB</b> ).		
	Start and run the engine from the pump controller	VERIFY	The pump controller alarm indicates that the ECM is in the alternate position - that the alternate ECM is active.

**3.15.10 TB-3 - Overspeed Switch**

Verify the firmware version by pressing the Menu button from the FPDP main screen. The firmware version will be visible on the bottom of the screen in the center.

Run this test according to the 'Alternate Method' with the engine **OFF**, the FPDP in **Auto** mode, and the pump controller **OFF**, if one or more of the below are true:

- It is not desired or possible to momentarily cause an actual overspeed condition.
- The engine has a firmware version prior to 1.55.
- The engine has an air shutoff valve.

**IMPORTANT:** *An Overspeed Test performed with the engine running on a fire pump drive engine with an air shutoff valve may cause damage to the engine.*

The engine speed is listed in the following 'Overspeed Exclusions' table:.

**Overspeed Exclusions**

Model	Speed Rating
CFP5E	2600 RPM
CFP7E	2600 RPM
CFP9E/CFP9E HHP	2300 RPM
CFP15E	2250 RPM
CFP23E	2100 RPM
CFP30E	2100 RPM
CFP60E	1800 RPM

**Primary Method (engine running)**

<b>TEST</b>	<p>Begin with the engine running from the pump controller and the FPDP in <b>Auto</b> mode. Press <b>MENU&gt; OVERSPEED TEST &gt; Run</b>.</p>		
	<p>A dialog box will appear alerting the user that the engine will ramp to an overspeed condition. If it is safe to do so, proceed with the test and select <b>Yes</b>. If not, select <b>No</b> and see the note below.</p>		
	<p>After the countdown timer expires, the engine will ramp to rated speed over a period of 5 seconds. Once the engine exceeds the overspeed threshold, the overspeed condition should be active.</p>	<b>VERIFY</b>	<p>When the timer expires, “ENGINE OVERSPEED” written in red will flash at the top of the FPDP screen until a reset occurs. The pump controller alarm indicates that an overspeed condition has occurred.</p>
	<p>The engine will shut down once the overspeed condition has occurred. Attempt to restart the engine by pressing the ‘Crank A’ or ‘Crank B’ button. The engine should not restart until a reset has occurred.</p>		<p>The FPDP shuts down the engine and does not allow it to restart until a reset has occurred.</p>
<p>Press the <b>RESET / STOP</b> button to reset the FPDP and clear the engine overspeed alarm on the pump controller.</p>			

**Alternate Method (engine off)**

<b>TEST</b>	<p>Begin with the engine <b>OFF</b> at the pump controller and the FPDP in <b>Auto</b> mode. Press <b>MENU&gt; OVERSPEED TEST &gt; Run</b>.</p>		
	<p>A dialog box will appear alerting the user that the engine will ramp to an overspeed condition. Since the engine is not running, an overspeed condition will NOT occur. Select <b>Yes</b> to run the test.</p>		
	<p>After the countdown timer expires, an engine overspeed fault will be simulated by the FPDP. “ENGINE OVERSPEED” will flash on the screen.</p>	<b>VERIFY</b>	<p>When the timer expires, “ENGINE OVERSPEED” written in red will flash at the top of the FPDP screen until a reset occurs. The pump controller alarm indicates that an overspeed condition has occurred.</p>
	<p>The engine will not restart until the overspeed condition has been cleared. Attempt to restart the engine by pressing the ‘Crank A’ or ‘Crank B’ button.</p>		<p>The FPDP does not allow the engine to restart until a reset has occurred.</p>
<p>Press the <b>RESET / STOP</b> button to reset the FPDP and clear the engine overspeed alarm on the pump controller.</p>			

**3.15.11 TB-2 - Crank Termination Switch**

The Fail to Start alarm is generated by the fire pump controller if it does not receive a crank terminate B+ signal from TB-2 of the FPDP

**IMPORTANT:** *To prevent damage to the starter, **disconnect the starter prior to performing the overcrank test** by removing power from the starter(s) B+ terminal(s). Ensure that the disconnected terminal is safely covered during the testing. Reconnect the starter at the conclusion of the overcrank testing.*

TEST	With the pump controller and the FPDP in <b>Auto</b> mode, simulate a pressure drop to energize the FPDP TB-1 and engage the crank sequence to start the engine.	VERIFY	The pump controller alarm indicates that an fail to start condition has occurred.
	The pump controller will repeat a 15-second crank and a 15-second rest 6 times by sending B+ voltage to either <b>TB9 - Main Battery Contactor One Coil or Battery Relay One Coil</b> and <b>TB10 - Main Battery Contactor Two Coil or Battery Relay Two Coil</b> in the FPDP.		

**3.15.12 Troubleshooting a Terminal Block Connection:**

ECM autoswitching must be enabled for NFPA 20 compliance To verify that autoswitching is enabled:.

TEST	Press <b>MENU &gt; ENGINE SETUP &gt; AUTOSWITCH</b>	VERIFY	ECM autoswitching is enabled.
	Ensure that <b>Autoswitch Enable</b> is <b>ON</b> (soft button is green).		

If the pump controller does not register a fault when it has been activated by the FPDP by the methods described in the above testing, the first step should be to check that the FPDP is activating the alarm which - for all cases other than **TB-3 – Overspeed Switch** and **TB2-Crank Termination Switch** - is a switch to ground. (**TB-3 - Overspeed Switch** and **TB-2-Crank Termination Switch** are switches to **B+** (Battery Positive).) To check the connection between the two devices, use a multimeter to manually verify the terminal block alarm signals in the FPDP are activating.

If the previous test is successful, and the pump controller does not register an alarm, a wiring issue exists between the FPDP and the pump controller.

# 4 - Operation

## 4.1 Introduction

This section outlines general operating information for starting and stopping the fire pump drive engine, as well as instructions for navigating the menu screens of the Fire Pump Digital Panel (FPDP). This manual is provided for your equipment and should be considered a part of that equipment. All personnel responsible for the operation and maintenance of the equipment should read and thoroughly understand this manual.

**▲ WARNING**

***Before preparing the equipment for normal service, complete all safety checks, remove all tools and foreign objects from the equipment, ensure all guards are in place and securely fastened, and alert area personnel that the equipment will be starting.***

## 4.2 Starting and stopping procedures

By default, the fire pump drive engine will turn on automatically when low system water pressure is sensed by the pump controller. The engine will continue to operate as long as TB-1 is active. When the TB-1 signal is terminated by the fire pump controller, the engine will stop or enter a cool down procedure by lowering the engine speed.

For testing purposes, the fire pump drive engine can be turned on and off locally using the buttons on the FPDP (see the FPDP Description section). If the engine fails to start automatically in the event of a fire emergency, follow the Emergency Starting/Stopping Procedure outlined in Section [4.2.2](#).

### 4.2.1 Local starting/stopping procedure

To start the engine locally from the FPDP:

1. Press the AUTO/MAN selector switch on the FPDP to place the engine in MANUAL mode.
2. Press the CRANK BATT A and/or CRANK BATT B button to crank the engine.

The engine may be stopped locally by pressing the RESET/STOP switch on the FPDP or by holding down the red Engine STOP button on the left side of the FPDP.

**NOTE:** *Upon release of the Engine STOP Button, the fire pump drive engine will attempt to restart, if there is still a “pump on demand” signal present from the fire pump controller. The engine must also be stopped at the fire pump controller.*

### 4.2.2 Emergency starting procedure

The engine will start automatically in the event of a fire emergency. However, if it fails to start automatically, the engine can be started locally. The following procedure outlines an emergency manual mode electrical start:

1. As shown in [Figure 4-1](#), open the water bypass valves (2) in the cooling water supply piping or the emergency cooling supply.

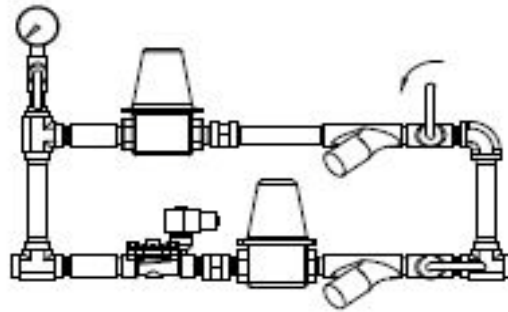

Figure 4-1 Water Bypass Valves

2. Press the AUTO/MAN selector switch on the FPDP to place the engine in MANUAL mode.
3. As shown in [Figure 4-2](#), open the FPDP panel door and slide the key switch override to the “RIGHT” position. Verify that LED 49 - KEY FB (key feedback) switch is lit.

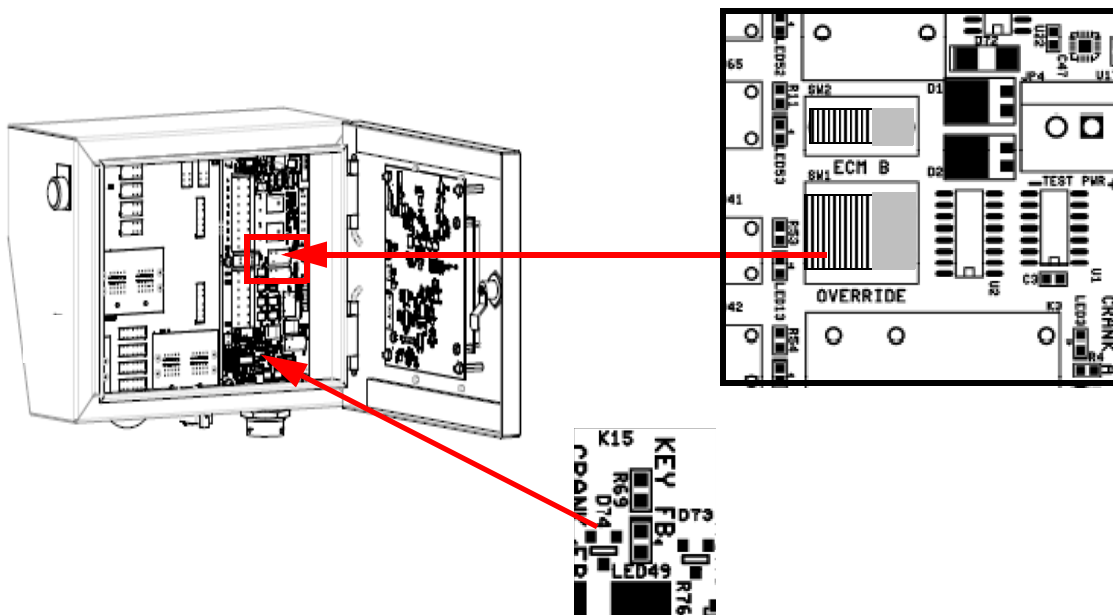

Figure 4-2 FPDP override switch

**CAUTION**

**To prevent damage to the starter, do not engage the starting motor more than fifteen seconds. Wait fifteen seconds between each attempt to start, up to six attempts.**

- As shown in [Figure 4-3](#), press downward on either the Battery A or Battery B contactor lever to start the engine. If crank contactor lever A does not engage the starter, repeat using crank contactor lever B. If the battery charge is low, press downward on both battery contactor levers at the same time. Release the contactor lever immediately after the engine starts.

**IMPORTANT:** *If the engine does not start after three attempts, check the fuel supply system. Absence of blue or white exhaust smoke during cranking indicates that no fuel is being delivered.*

- Check that the engine starts and operates at the rated speed.

**IMPORTANT:** *Engine oil pressure must be indicated on the gauge within fifteen seconds after starting.*

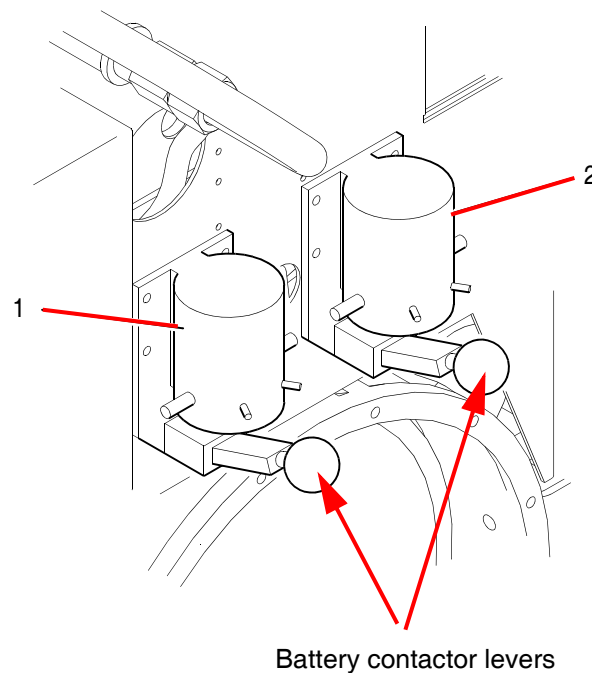

- Battery A starter contactor
- Battery B starter contactor

**Figure 4-3 Manual starter contactors**

The engine may be stopped locally by returning the key switch override to the “LEFT” position.

**NOTE:** *When the key switch override is in the “RIGHT” position, neither the red Engine STOP button on the side of the FPDP nor the RESET/STOP switch on the FPDP will stop the engine.*

### 4.3 Fire Pump Digital Panel (FPDP) screens and adjustments in automatic mode

The FPDP consists of an LCD touchpad that displays the fire pump drive engine tachometer, coolant temperature, oil pressure, Battery A voltage, Battery B voltage and hour meter, as well as includes three soft keys:

- **SCREEN** soft key
- **MENU** soft key
- **IDLE** soft key (electronic engines in **MAN** mode, only)



Figure 4-4 FPDP User Interface screen (electronic engine)

**NOTE:** Electronic engines display tachometer, engine temperature and oil pressure values from J1939. Mechanical engines display parameters via sensors added by Cummins.

**NOTE:** When the key switch is not on, the coolant temperature defaults to “0 °F” (or “0 °C”) and the oil pressure defaults to “0 PSI” (or “0 kPa”).

The FPDP LCD will go into **SLEEP MODE** after fifteen minutes of inactivity by the user. The FPDP LCD will resume normal display features when the user presses a hard button or touches the LCD screen.

#### 4.3.1 The SCREEN soft key

The **SCREEN** soft key, on the bottom right of the LCD, deactivates and activates an overlay box which lies atop the tachometer signal (the engine speed is still digitally displayed). The overlay is used to:

- Automatically - Warn the operator of ECM and/or DPEM faults, when applicable (see Section 4.3.2.6 [FAULT CODES screen](#)); and/or
- Operator-selected - Display additional analog values not required by NFPA 20.

The overlay background color will display in gray, unless there is an active fault present. Fault overlays will display in the color of the most severe fault. To deactivate the Fault overlay, press the **SCREEN** soft key to make the overlay disappear from the LCD.



As shown below, the Analog Values overlay background color displays in gray.

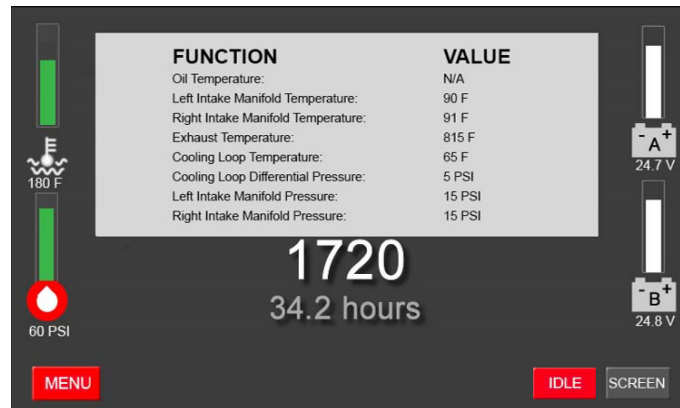

**Figure 4-5 Analog Values overlay (electronic engine)**

Additional values that may be displayed include:

- Exhaust temperature (when a thermocouple is installed and terminated to the Power Board).
- Cooling loop raw water temperature and strainer status on FM-approved and UL-listed fire pump drivers. The Analog Values overlay can assist in troubleshooting the cooling loop by identifying issues with the pressure sensors.
- J1939 parameters.

**NOTE:** *The Oil Temperature value (from J1939) will only be shown on CFP11E and CFP15E.*

**NOTE:** *The Intake Manifold Pressure (from J1939) will be showing 0 PSI at no load.*

**NOTE:** *A thermocouple must be purchased and installed from Cummins in order for exhaust temperature values to display. If a thermocouple is not connected to the Power Board or the thermocouple input temperature is less than 200 °F, the Exhaust Temperature will display 0 °F.*

To deactivate the Analog Values overlay, press the **SCREEN** soft key to make the overlay disappear from the LCD.

### 4.3.2 The MENU soft key - Settings Menu

If the operator presses the **MENU** soft key from the FPDP User Interface screen, the Settings Menu screen appears as shown below.

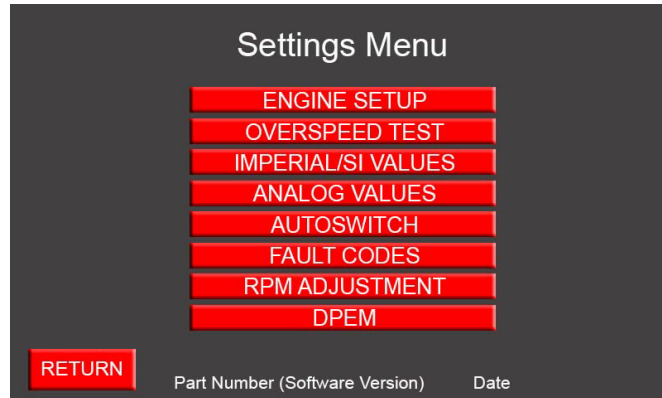

**Figure 4-6 Settings Menu screen (electronic engine)**

The Settings Menu provides options for further operator input and monitoring of fire pump drive engine parameters. Press the corresponding soft key to access a sub-menu.

#### 4.3.2.1 ENGINE SETUP screen

The fire pump drive engine was preconfigured with custom options (if applicable) at the factory prior to shipping to the customer. The System Options screen provides a view of the custom configuration that has been set up for your fire pump drive engine. The Cummins Service Department must be notified if any of these parameters are adjusted in the field.

1. Starting at the User Interface screen, press the **MENU** soft key.
2. As shown below, press the soft number keys to enter password “806” in the Engine Setup Login screen.
3. Then press **SUBMIT** to access the Engine Setup screen.

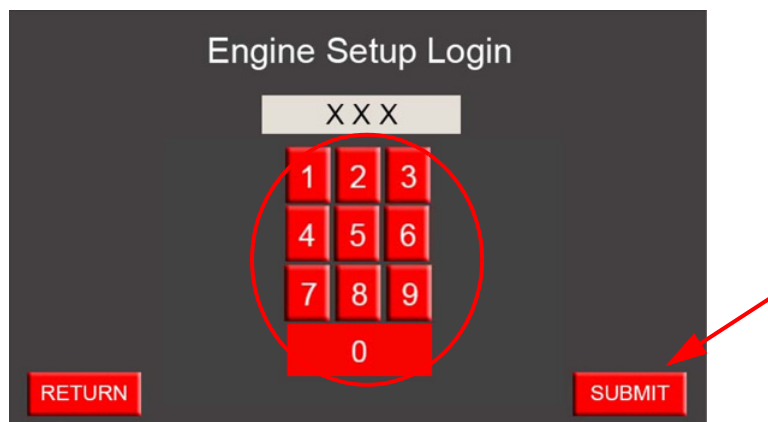

**Figure 4-7 Typical Engine Setup Login screen**

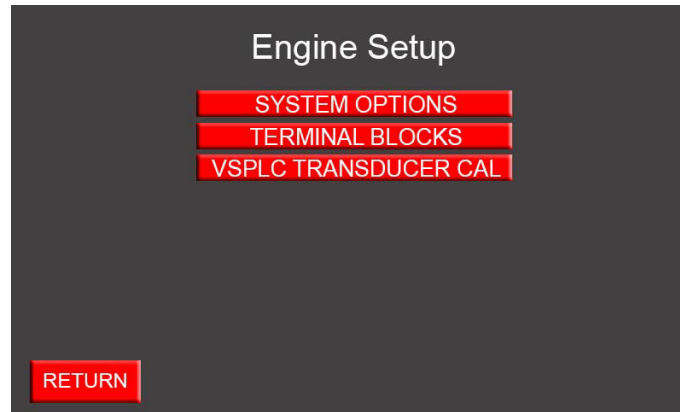

**Figure 4-8 Engine Setup screen (electronic engine)**

### Engine Setup screen - SYSTEM OPTIONS

The System Options sub-menu displays the custom configurations of the fire pump drive engine. When active, the soft buttons turn green in color and display “ON”. Conversely, the soft button will turn red in color and display “OFF”, if the feature is disabled. To change a numeric data field, tap the data field to access the popup keyboard and enter different data.

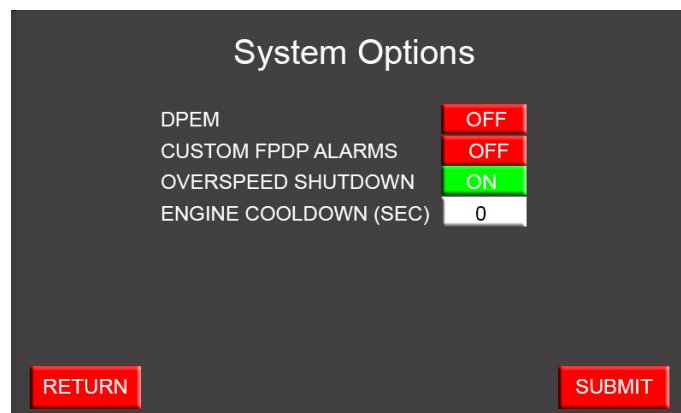

**Figure 4-9 System Options screen (electronic engine)**

The custom options of the System Options sub-menu include:

**DPEM** – When active, the FPDP initiates communications with the Digital Panel Expansion Module (DPEM).

**CUSTOM FPDP ALARMS** – When active, the custom FPDP Terminal Block assignments will be activated.

**OVERSPEED SHUTDOWN** – When active, the FPDP shuts the engine fueling off when the engine speed reaches or exceeds 115% of the configured rated speed.

**ENGINE COOLDOWN (SEC) (on electronic engines only)** - When active, the operator shall denote a specific amount of seconds to idle the fire pump drive engine. When the engine cool down is disabled, the seconds shall be set to “0” (see [4.5 Engine/turbocharger cool down](#)).

Press either **RETURN** or **SUBMIT** to return to the Engine Setup menu.

---

## Engine Setup screen - TERMINAL BLOCK TEST

The TERMINAL BLOCKS sub-menu provides a convenient means of checking the signal integrity between the fire pump controller and the terminal block interface inside the FPDP.

As shown in [Figure 4-10](#), any of the signals on the terminal block interface can be manually activated by pressing the respective red soft key. When the button turns green, the signal is active.

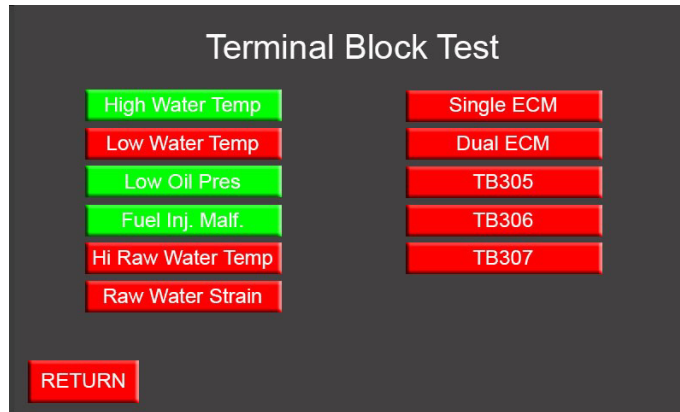

**Figure 4-10 Typical Terminal Block Test screen**

To perform a Terminal Block Test:

1. Starting at the User Interface screen, press the **MENU** soft key;
2. Press the **ENGINE SETUP** soft key from the Settings menu;
3. As shown in [Figure 4-7](#), press the soft number keys to enter password “806” in the Engine Setup Login screen.
4. Press the **TERMINAL BLOCKS** soft key from the Engine Setup menu;
5. Press the soft key corresponding to the terminal block requiring verification;

**NOTE:** *If the selected terminal block soft key turns green, but the pump controller alarm does not activate, troubleshoot the terminal block connection for a B+ or ground signal (see the Section [FPDP Signal and Control Connections](#) or contact your local Cummins Sales and Service representative).*

**NOTE:** *For electronic engines, the Fuel Inj. Malf. (fuel injection malfunction) can only momentarily be set.*

6. To exit the Terminal Block Test menu, press the **RETURN** soft key to return to the Engine Setup menu.

**NOTE:** *Oil pressure and coolant temperature alarms will not latch upon backing out of the menu, but instead will be driven directly from datalink values.*

---

**Engine Setup screen -VSPLC TRANSDUCER CAL (electronic engines with VSPLC capability, only) (optional)**

**NOTE:** The VSPLC TRANSDUCER CAL screen **only** applies to electronic VSPLC fire pump drive engines. The settings in this menu are meaningless unless VSPLC is enabled. This section is not applicable to mechanical engines.

To account for a system pressure differential, the operator may enter a pressure offset. This same pressure offset is used throughout the entire incoming pressure range. To access the VSPLC Transducer Configuration screen:

1. Starting at the User Interface screen, press the **MENU** soft key.
2. Press the **ENGINE SETUP** soft key from the Settings menu.
3. As shown in [Figure 4-7](#), press the soft number keys to enter password “806” in the Engine Setup Login screen.
4. Press the **VSPLC TRANSDUCER CAL** soft key from the Engine Setup menu.
5. As shown in [Figure 4-11](#), press the VSPLC Offset (PSI) data field to activate the popup keyboard and enter the desired pressure offset.

**NOTE:** The software limits the pressure offset to +/- 10 PSI with a resolution of 0.1 PSI.

6. Then press **SUBMIT**.

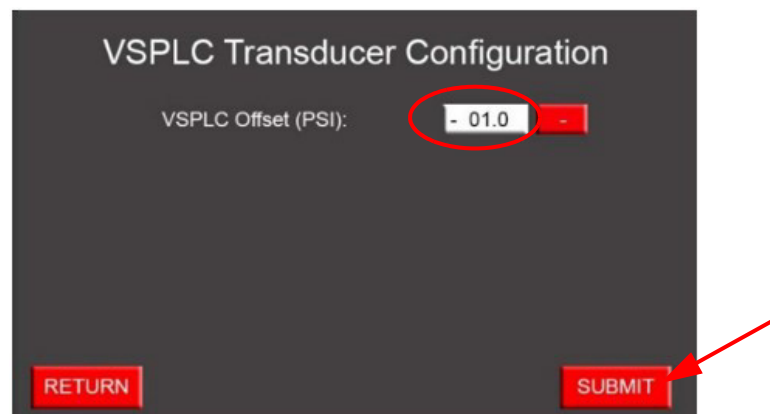

**Figure 4-11 VSPLC Transducer Configuration**

7. Press **RETURN** to return to the Engine Setup menu.

#### 4.3.2.2 OVERSPEED TEST screen

The Overspeed Test screen shown below allows the operator to simulate an overspeed shutdown for all engine models. Refer to “Start-up Validation” in the Installation Section of this manual for detailed instructions on how to simulate an overspeed shutdown.

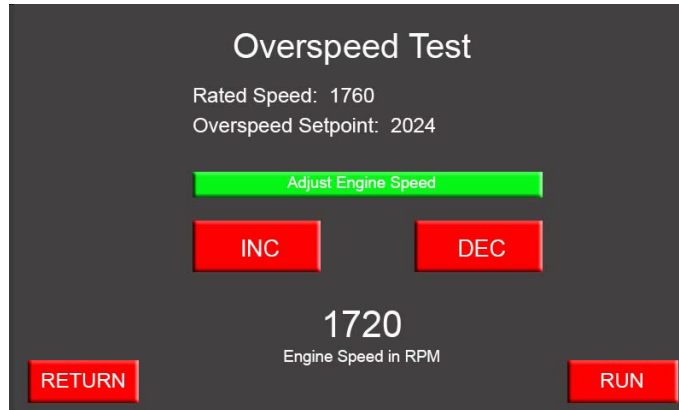

Figure 4-12 Overspeed Test screen

#### 4.3.2.3 IMPERIAL/SI VALUES screen

The Imperial/SI Values screen, shown in [Figure 4-13](#), allows the operator to select Imperial or *Système Internationale* (SI) (also known as metric) units of measurement. The default units of measure are Imperial units of degrees in Fahrenheit and pounds per square inch (PSI), but the user may elect degrees in Celsius or kilo Pascal (kPa).

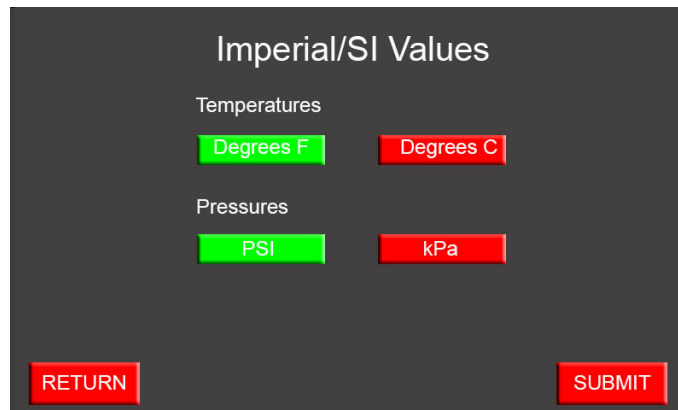

Figure 4-13 Typical Parameter Units screen

To change the displayed units of measurement:

1. Starting at the User Interface screen (Main Menu), press the **MENU** soft key.
2. Press the **IMPERIAL/SI VALUES** soft key from the Settings Menu.

3. Press the soft key for the desired unit of measure.
4. Press the **SUBMIT** soft key.
5. To exit the Imperial/SI Values menu, press the **RETURN** soft key.

#### 4.3.2.4 ANALOG VALUES screen

To view the information about the fire pump drive engine in digital format:

1. Starting at the User Interface screen (Main Menu), press the **MENU** soft key.
2. Press the **ANALOG VALUES** soft key from the Settings Menu.
3. To exit the Analog Values screen (shown below), press the **RETURN** soft key.

**NOTE:** *The display choice of Imperial or SI values is made using the Imperial/SI Values screen.*

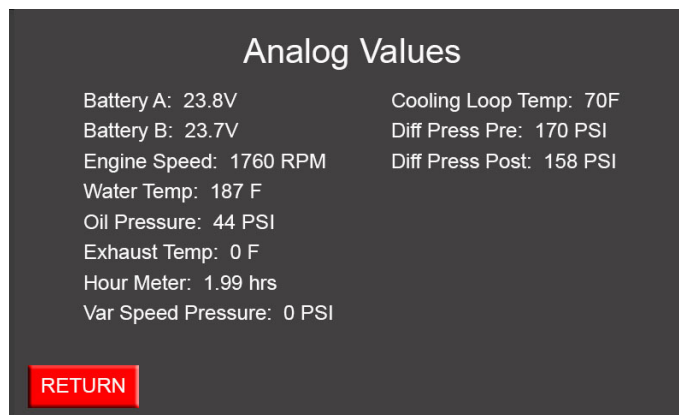

**Figure 4-14 Sample Analog Values screen**

#### 4.3.2.5 AUTOSWITCH screen

**NOTE:** *The AUTOSWITCH screen is on electronic engines, only. This section is not applicable to mechanical engines.*

The National Fire Protection Association (NFPA) 20 Standard, as well as Underwriters Laboratories (UL) and Factory Mutual (FM) Standards, requires redundancy for fire safety systems. If the fuel system is electronically-controlled, switching of ECMs must be controlled automatically. Cummins refers to this process as "ECM Autoswitching." When the FPDP switches ECMs automatically, the fault code responsible for the last switch can be found on the Autoswitch screen. The FPDP will activate the ECM keyswitch for fifteen seconds every thirty minutes to validate communications with the ECM.

**IMPORTANT:** *In order to maintain NFPA 20 compliance, autoswitching must be **enabled (ON)**.*

As shown in [Figure 4-15](#), the Autoswitch Settings screen allows the operator to disable or enable this autoswitch capability.

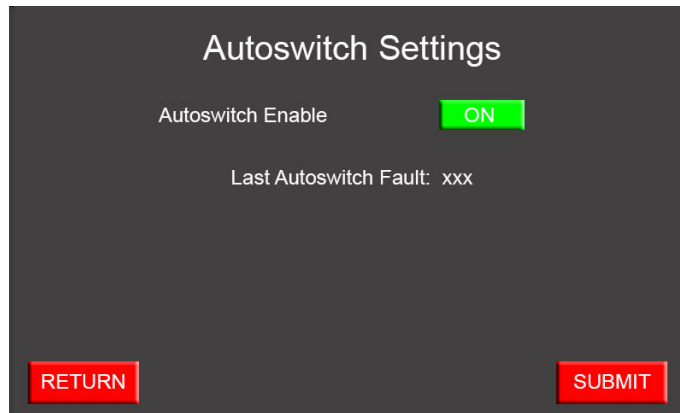

**Figure 4-15 Typical Autoswitch Settings screen**

To change the autoswitch setting:

1. Starting at the User Interface screen, press the **MENU** soft key;
2. Press the **ENGINE SETUP** soft key from the Settings menu;
3. As shown in [Figure 4-7](#), press the soft number keys to enter password “806” in the Engine Setup Login screen.
4. Press the **AUTOSWITCH** soft key from the Settings Menu.
5. Press the **ON/OFF** soft key - the soft key displayed (in green) indicates which mode has been selected.
6. Press the **SUBMIT** soft key.
7. To exit the Autoswitch Settings screen, press the **RETURN** soft key.



#### 4.3.2.6 FAULT CODES screen

**NOTE:** *The FAULT CODES screen is on electronic engines, only. This section is not applicable to mechanical engines.*

As shown in the Description Section, fault codes diagnosed by the ECM are displayed in a yellow or red overlay box which lies atop the tachometer signal (the engine speed is still digitally displayed) to alert the operator to service the engine as soon as possible. Only the first seven active ECM faults will be displayed in the overlay.

As shown in [Figure 4-16](#), the Fault Codes screen displays the full list of active faults. To view the information about the fire pump drive engine active faults:

1. Starting at the User Interface screen (Main Menu), press the **MENU** soft key.
2. Press the **FAULT CODES** soft key from the Settings Menu.
3. To exit the **FAULT CODES** menu, press the **RETURN** soft key.

For more information about fault codes and their meanings, see the Fault Code Section of this manual or contact your local Cummins Distributor.

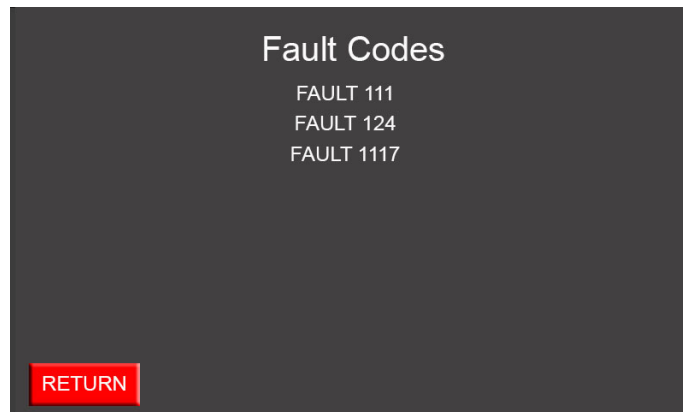
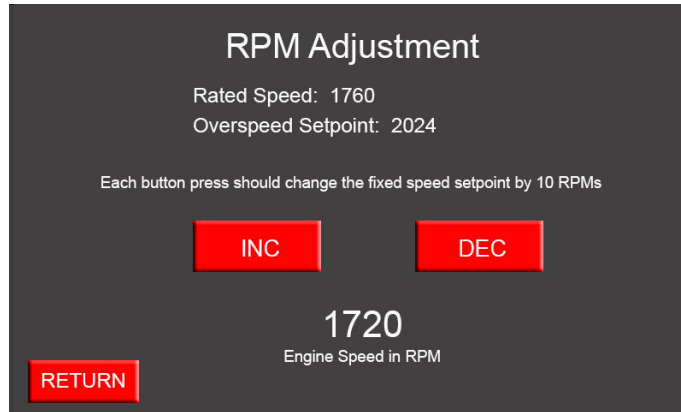

**Figure 4-16 Sample Fault Codes screen**

#### 4.3.2.7 RPM ADJUSTMENT screen

**NOTE:** *The RPM ADJUSTMENT screen is on electronic engines, only. This section is not applicable to mechanical engines.*

As shown in [Figure 4-17](#), the RPM Adjustment screen allows the operator to make on-site adjustments to **FIXED SPEED** fire pump drive engines. Each press of the INC soft key or the DEC soft key will increase or decrease the engine speed setpoint by 10 RPM (not to exceed +/-50 RPM) for electronic engines.



**Figure 4-17 Typical RPM Adjustment screen**

The engine operating speed was factory set during manufacturing and test procedures. If the speed does not match the engine RPM shown on the factory setting plate, follow these steps to adjust the speed setting:

1. Starting at the User Interface screen (Main Menu), press the **ECM A** Selector switch.
2. Press the **MENU** soft key.
3. Press the **RPM ADJUSTMENT** soft key from the Settings Menu.
4. Press either the **INC** soft key or the **DEC** soft key to change the ECM RPM setpoint.
5. Press the **RETURN** soft key.
6. Press the **RESET/STOP** switch on the FPDP and wait for thirty seconds.
7. Repeat Steps 1 through 5 for **ECM B**.

**NOTE:** *The speed setpoint adjustments must be made on each ECM to experience the same system level of performance on the alternate ECM.*

**IMPORTANT:** *Never switch from ECM A to ECM B while the engine is running.*

### 4.3.2.8 DPEM (optional)

As shown in Figure 4-18, the DPEM screen displays the function name, status, alarm setpoint, and relay associated with the alarm (if applicable) of any custom inputs that are configured on the fire pump drive engine. When an analog input parameter crosses the alarm setpoint or a switched input is active, all information associated with that parameter will turn red in color. To access the DPEM screen:

1. Starting at the User Interface screen (Main Menu), press the **MENU** soft key.
2. Press the DPEM soft key from the Settings Menu.
3. To exit the DPEM screen, press the **RETURN** soft key.

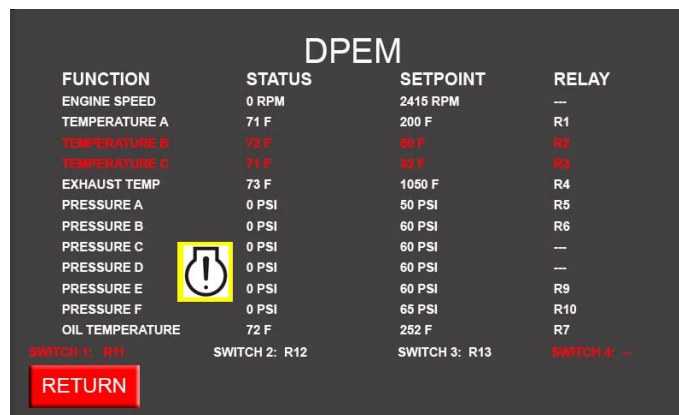

Figure 4-18 Sample DPEM screen

If communications between the FPDP and DPEM are compromised, a “DPEM COMMS ERROR” message will appear at the top of the screen.

### 4.4 FPDP screens and adjustments in manual mode - IDLE soft key

**NOTE:** The **IDLE** soft key shown in Figure 4-19 displays in red while the engine idle command is inactive. The **IDLE** soft key will display in green when the engine idle command is active.



Figure 4-19 IDLE soft key

With the FPDP in manual mode and using the **IDLE** soft key, the FPDP can now command electronic engines to idle. The operator can choose to idle the fire pump drive engine to warm up the engine for weekly testing and/or to evaluate water leaks during commissioning. To manually place the fire pump drive engine in idle:

1. Select **MAN** on the **AUTO/MAN** mode switch on the FPDP to place the fire pump drive engine in manual mode.
2. Press the **IDLE** soft key on the screen.

**NOTE:** Engaging the **IDLE** soft key will turn the **IDLE** soft key display from red to green, engaging the engine idle command.

3. Press the **BATT A** or the **BATT B** Momentary Start switch to start the engine.
4. To disengage manual engine idle, press the **IDLE** soft key on the screen. The **IDLE** soft key will return to red in color.

The engine will ramp to rated speed. The engine will also ramp to rated speed (for fixed speed applications) or enter a closed loop VSPLC mode, if enabled, when TB-1 becomes active while the engine is idling.

#### 4.5 Engine/turbocharger cool down

The FPDP has the ability to idle an electronic engine for up to three minutes when a shutdown has been commanded from the fire pump controller. The cool down feature promotes engine turbocharger longevity. During engine cool down, the FPDP will display an “Engine Cooldown Active:” message (shown in [Figure 4-20](#)).

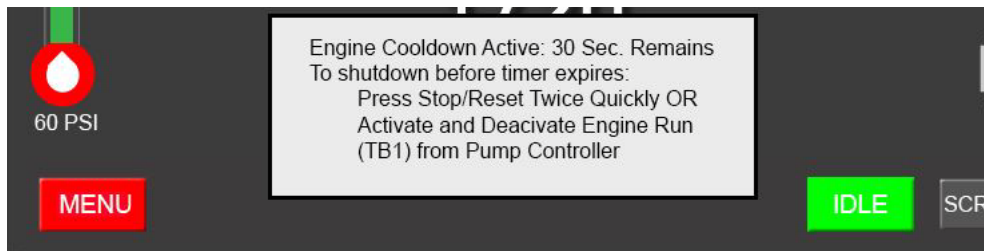

**Figure 4-20 Engine/turbocharger cool down**

During engine cool down, the fire pump drive engine may shutdown automatically - prior to the timer expiring - to protect the engine. The operator also has the option to shut down the engine manually from the fire pump controller or the FPDP during cool down, if necessary.

**IMPORTANT:** All fire pump drive engines are shipped from the factory with the cool down feature disabled. This feature must be manually enabled by the customer. Prior to enabling the cool down feature, ensure all operators are trained on the operation of this engine cool down feature.

---

#### 4.5.1 Automatic shutdown - cool down timer

The fire pump drive engine will automatically shutdown when the Engine Cooldown timer expires.

#### 4.5.2 Automatic shutdown - engine protection

The FPDP will automatically shut the engine off and during engine cool down if:

- Low oil pressure is sensed;
- High coolant temperature is sensed; and/or
- Communications with the ECM are lost.

#### 4.5.3 Manual shutdown - from the fire pump controller

During cool down, the fire pump drive engine can be shut down manually from the fire pump controller by:

1. Turning the fire pump controller switch to **OFF** (deactivating TB-1). NOTE: *The FPDP will keep the fire pump drive engine running to idle until the timer expires; AND*
2. Turning the fire pump controller from **OFF** to **MAN** (manual) and back to **OFF** (reactivating and deactivating TB-1). The fire pump drive engine will shut down immediately.

#### 4.5.4 Manual shutdown - from the FPDP

The engine can also be shutdown manually by pressing the **RESET/STOP** switch on the FPDP two times in succession.

This page is intentionally left blank.

# 5 - Maintenance

## 5.1 Introduction

Before performing maintenance procedures, read and understand [1 - Safety](#) of this manual. Improper performance or lack of critical information could result in personal injury or equipment damage.

Cummins encourages our customers to perform maintenance and repairs whenever necessary. However, servicing complex components within the normal warranty period may void the Cummins warranty and any specified warranty extended by the manufacturer of Original Equipment Manufacturer (OEM) products. See the warranty information at the beginning of this manual.

Maintenance procedures should be performed by skilled technicians who are familiar with the equipment, local regulations, and service procedures for fire pump drive engine and pump systems. Improper maintenance can damage the engine or the fire pump drive engine, or cause severe personal injury.

The National Fire Protection Association (NFPA) 25 Standard outlines the maintenance tests to be performed to validate automatic and manual operational requirements for field acceptance testing.

Cummins recommends that the engine be maintained according to the Cummins Operation and Maintenance manual for that engine family.

**NOTE:** *If your engine is equipped with a component or accessory not manufactured by Cummins, refer to the component manufacturer's vendor supplied literature for specific maintenance recommendations.*

## 5.2 Engine operation reports

The engine must always be maintained in top mechanical condition. Proper maintenance of the fire pump drive engine requires documenting regular running reports to include the following:

- Low engine oil pressure.
- Engine surge.
- Erratic operation or frequent shutdowns.
- Any warning lamps flashing or staying illuminated.
- Abnormal coolant or oil temperature.
- Unusual engine noise or vibration.
- Excessive smoke.
- Excessive use of coolant, fuel, or engine oil.
- Any fluid leaks.
- Loose, worn, or damaged parts.

## Maintenance

---

The weekly running report also helps to make provisions for more extensive maintenance, as the reports indicate the necessity.

The Fault Codes displayed on the Fire Pump Digital Panel assist in recording operation irregularities. See [6 - Troubleshooting](#) of the model-specific English manual for a listing of Fault Codes.





## 5.3 Weekly maintenance

When the engine is running, be alert for mechanical problems that could create unsafe or hazardous conditions.

### 5.3.1 General

Each week, a general walk-around inspection should include the following areas:

1. Check fluid levels before starting the engine. Check oil pressure and coolant temperatures frequently. Most engine problems give an early warning.
2. Look and listen for changes in engine performance, sound, or appearance that will indicate that service or repair is needed. Be alert for misfires, vibration, excessive exhaust smoke, loss of power, or increases in oil or fuel consumption.
3. Check the engine appearance for excessive heat, wiring short circuits, excessive end-play, vibrations, excessive wear, excessive abrasion, damaged electrical wiring, or loose electrical wiring.
4. Check the engine for odors of diesel fuel, burning rubber, electrical system failure, exhaust fumes, or smoke.

**WARNING**

**Engine fuel is highly flammable and represents an extreme hazard for fire or explosion when exposed to electrical sparks or open flame. Clean up spilled fuel immediately. Keep sources of electrical spark or open flame away from a fuel source.**

### 5.3.2 Air cleaner filter and piping

On a weekly basis, perform the following inspections:

1. Visually inspect the air intake filter and piping daily for blockage, damage to piping, loose clamps, or punctures that can allow debris to enter the engine. If there is a blockage, the service indicator will be activated. Refer to [Figure 2-2](#).

**NOTE:** Turbocharged engines must be operated at rated revolutions per minute (RPM) and full load to check maximum intake air restriction.

**NOTE:** Cummins recommends using an air cleaner filter element as listed on the [engine data sheet](#).

**CAUTION**

**Never operate the engine without an air cleaner. Intake air must be filtered to prevent dirt and debris from entering the engine and causing premature wear. Dirt or foreign objects could cause engine damage.**

- a. If the red indicator flag is at the raised position in the window, clean or replace the air filter per the manufacturer's recommendation as required. Do not remove the felt washer from the indicator. The felt washer absorbs moisture.
- b. After the air cleaner has been serviced, push the flag in to reset the service indicator.

**IMPORTANT:** See the [engine data sheet](#) for maximum intake air restriction.

2. Check for corrosion under the clamps and hoses of the intake system piping. Corrosion can allow corrosive products and dirt to enter the intake system. Disassemble and clean as required.
3. Replace any damaged air filter or hoses and tighten loose clamps, as necessary, to prevent the air system from leaking. Torque the hose clamps to the recommended torque value. Refer to the [torque tables](#).

### 5.3.3 Cooling system

**CAUTION**

**Do not remove a coolant pressure/fill cap from a hot engine. Shut down the engine and wait until the coolant temperature is below 50 °C (120 °F) before removing the pressure cap. Heated coolant spray or steam can cause severe personal injury.**

On a weekly basis, perform the following inspections on the cooling system:

1. Inspect the cooling water piping, coolant heat exchanger tanks, charge air cooling system (if applicable), engine coolant hoses, and hose clamps for loose fittings, leaks, damage, and corrosion.
  - a. Tighten the hose clamps, as necessary.
  - b. Check for cracks, holes, or other damage. Repair or replace as necessary.

**CAUTION**

**Never use a sealing additive to stop leaks in the cooling system. This can result in cooling system plugging and inadequate coolant flow, causing the engine to overheat.**

2. With the coolant expansion tank at ambient temperature, press down, unscrew, and remove the pressure cap as shown in [Figure 2-2](#).
  - a. Ensure that the coolant level is visible by checking the coolant level sight gauge.
  - b. Add coolant, as required. DO NOT OVERFILL!

**NOTE:** Supplemental engine coolant should be a mixture of 50% ethylene glycol antifreeze and 50% water to avoid engine damage.

3. Check the antifreeze concentration at least six times a year or whenever coolant is added to the cooling system by using a refractometer.
4. Drain a small amount of coolant from the return line petcock and inspect the coolant for excessive rust or particulate matter. Change the coolant more frequently if particles are present.

**CAUTION**

**Do not mix coolant brands or chemical solutions, as this could damage the cooling system. Keep a record of the coolant concentration and manufacturer with the engine maintenance records.**

5. Check for soft, overly-pliant hoses, oxidation, and loose hose clamps. Torque the hose clamps to the recommended torque value. Refer to the [torque tables](#). Replace damaged hoses and clamps as required.
6. Check the coolant heat exchanger tanks for leaks, damage, and dirt buildup. Clean and repair as required.

### 5.3.4 Engine oil system

**WARNING**

**Perform the specific checks in this section only after the engine is fully stopped. Unless tests require engine operation, disconnect the battery leads from the batteries (negative terminal first). Contact with exposed or moving components can cause severe personal injury.**

Inspect the engine oil system on a weekly basis following these steps:

1. For accurate dipstick readings, shut off the engine and wait approximately ten minutes to allow the oil in the upper portions of the engine to drain back into the crankcase.
2. As shown in [Figure 5-1](#), check the oil level at the engine dipstick.
  - If the oil level is greater than the high mark (H), drain the excess oil and recheck the level.
  - If the oil level is consistently below normal after a fill, check for leaks, loose or damaged gaskets, or oil in the coolant system. If the oil level is below the low mark (L), add the equivalent type oil.

**NOTE:** Cummins recommends using Premium Blue<sup>®</sup> 15W-40 Multi-viscosity Lubricating Oil or equivalent.

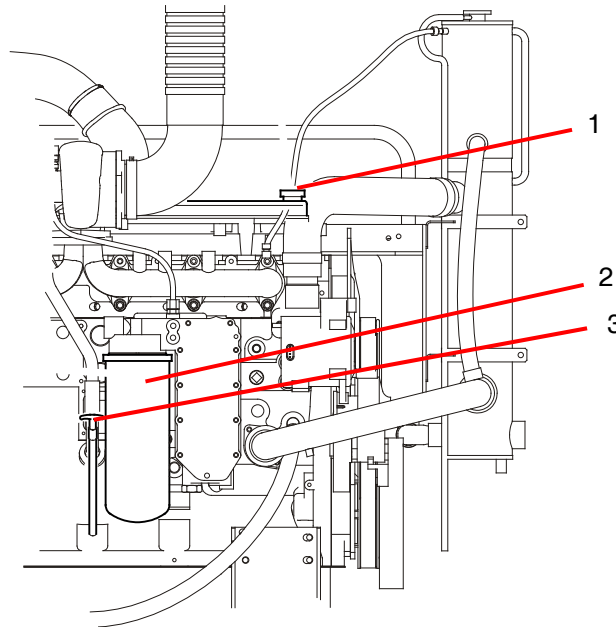

1. Engine oil fill port
2. Engine oil filter
3. Engine oil dipstick

**Figure 5-1 Oil level dipstick (typical)**

---

### 5.3.5 Fuel system



**Engine fuel is highly flammable and represents an extreme hazard for fire or explosion when exposed to electrical sparks or open flame. Clean up spilled fuel immediately. Keep sources of electrical spark or open flame away from a fuel source.**

To inspect the fuel system:

1. Shut off the engine.
2. Inspect the fuel supply line, return line, filter and fittings for cracks or abrasions.
  - a. Ensure the lines are not rubbing against anything that could damage the fuel system hoses. Repair any leaks or alter line routing to eliminate wear immediately.
  - b. Relieve fuel line pressure by carefully loosening the fuel inlet line.

**NOTE:** Refer to the [engine data sheet](#) for Cummins recommended replacement components.

### 5.3.6 Engine exhaust system

With the engine operating, inspect the entire exhaust system: exhaust manifold, exhaust flex, muffler, and piping.

Check for leaks at all connections, welds, gaskets, and joints. Make sure that the exhaust pipes are not heating surrounding areas excessively. Repair any leaks immediately.

### 5.3.7 Electrical supply and controls

Check the terminals on the starting batteries for clean and tight connections. Loose or corroded connections create resistance which can hinder starting. Inspect the FPDP harness connections to be sure they are secure.

### 5.3.8 Crankcase ventilation hose

Inspect the crankcase ventilation hose for wear, damage, sludge, blockage, or dirt buildup (refer to [Figure 2-2](#)). Clean the ventilation hose, if obstructed or blocked. Replace a worn or damaged hose.

### 5.3.9 Heat exchanger - cooling water strainers

As shown in Figure 5-2, the (two) cooling water strainers should be cleaned weekly to remove sediment.

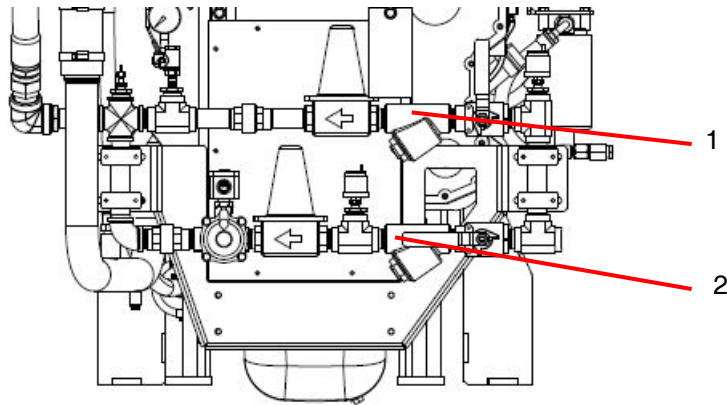

1. Bypass raw water strainer
2. Normal raw water strainer

**Figure 5-2 Cooling water strainer (typical)**

To clean the normal line strainer, ensure that the normal line valves are closed and the bypass line valves are open.

To clean the bypass line strainer, ensure that the bypass line valves are closed and the normal line valves are open.

For each cooling water strainer:

1. Remove the plug.
2. Inspect and remove any debris.
3. Install the strainer plugs.
4. When finished, open the normal line valves and close the bypass line valves for normal operation.

### 5.3.10 Batteries

**CAUTION**

***Batteries can emit explosive gases during charging. To reduce the possibility of personal injury, always ventilate the battery compartment before servicing the batteries.***

**CAUTION**

***To reduce the possibility of arcing, remove the negative (-) battery cable first and attach the negative (-) battery cable last.***

---

For proper weekly maintenance of the batteries:

1. Keep the batteries clean by wiping them with a damp cloth whenever dirt appears excessive.
2. Use a battery hydrometer to check the specific gravity of the electrolyte in each battery cell. A fully-charged battery will have a specific gravity of 1.260. Replace the battery, if the specific gravity reading is below 1.215.
3. Check the battery wiring and cable connections for loose, corroded, worn, or damaged cables. Check both connectors at the alternator, battery connections, and engine grounding lug (near the starter motor).
  - a. If the battery cables are corroded, remove the battery cable clamps, starting with the negative (-) battery cable.
  - b. Use a fine emery cloth or a wire brush to clean the cable clamps and battery cables. The metal should be shiny.
  - c. Wash the battery terminals with a solution of baking soda and water:

2 oz (1/4 cup) baking soda to 0.94 liter (1 qt) of water
  - d. Be careful to prevent the solution from entering the battery cells, and flush the batteries with clean water when done.
  - e. After cleaning the connections, coat the terminals with a light application of petroleum jelly.
  - f. Reinstall and tighten the cable clamps.

**▲ WARNING**

***Battery electrolyte (sulfuric acid) is highly caustic and can burn clothing and skin, or cause blindness. Wear protective clothing, impervious neoprene gloves, safety goggles, or full-face shield when working with the batteries.***

4. Check the electrolyte level in the batteries monthly. If low, fill the battery cells to the bottom of the filler neck with distilled water.
5. Check for continuity between terminals using a digital multimeter or other test equipment. Also check the insulation resistance to ground. Correct any electrical faults.
6. Reinstall the battery cables; attach the negative (-) battery cable last.

### 5.3.11 Engine test run

Start the engine at least once a week for a minimum of thirty minutes with as much load as possible. Periods of no-load operation should be held to a minimum, because unburned fuel tends to accumulate in the exhaust system. Refer to the operating instructions in [4 - Operation](#).

Check that the engine starts and operates at the recommended fire pump drive engine speed specification and inspect the following:

1. Check that the engine oil pressure is indicated on the gauge within fifteen seconds after starting.
2. Check that the engine has attained a normal running temperature after running the engine for a minimum of thirty minutes.

3. Observe that the engine is operating at the proper operating speed. (If the engine is not operating at the proper speed, see Section [5.3.12 Engine operation checks](#).)
4. Check for unusual engine noise. Listen for any unusual engine noise which can indicate that service is required.
5. Ensure that the oil pressure is greater than 69 kPa (10 psi).
6. Check that the coolant temperature is between 70 °C (158 °F) and 107 °C (225 °F).
7. Check that both battery voltmeters indicate 12 VDC for standard or 24 VDC for optional operating systems.
8. Check that the air filter service indicator has not popped-up, indicating an air filter blockage. Replace the air filter as required.

End the test run by pressing and holding the overspeed RESET/STOP switch until the engine stops.

### 5.3.12 Engine operation checks

The following service inspections ensure that the engine starts and operates properly under normal conditions.

**▲ WARNING**

***Before equipment operation, ALL guards, covers, and protective devices MUST BE in place and securely fastened. Serious personal injury could result from contact with exposed or moving components.***

#### 5.3.12.1 Crank termination setpoint

The speed switch crank termination setpoint is factory-set at 600 RPM and should not be changed from this value.

#### 5.3.12.2 Engine speed adjustment

The electronic engine operating speed was factory set during manufacturing and test procedures. If the speed unintentionally does not match the engine RPM shown on the factory setting plate, refer to [Section 4 - Operation: RPM Adjustment Screen](#).

### 5.3.13 Engine coolant heater

**NOTE:** *Perform this inspection procedure twenty-four hours after shutting off the engine.*

The engine coolant heater must maintain an engine coolant temperature of 49 °C (120 °F) or above. The engine block must be warm to the touch (38 °C (100 °F)) in the water jacket areas.

If the heater does not appear to be working correctly, contact a Cummins Authorized Repair Location.



---

## 5.4 Annual maintenance

All checks or inspections listed under previous maintenance intervals must also be performed at the time of the annual maintenance, in addition to those listed *only* under the annual maintenance interval.

### 5.4.1 Electrical components



***AVOID SERVICING complex components such as: printed circuit boards, programmable controllers, and ECMs not specifically authorized by Cummins. Contact a Cummins Authorized Repair Location before performing any extensive maintenance.***



***To reduce the possibility of arcing, remove the negative (-) battery cable first and attach the negative (-) battery cable last.***

The electrical components of the fire pump drive engine must be thoroughly inspected on an annual basis. Remove the battery terminal cables, starting with the negative (-) cable first and check the following:

1. Inspect the electrical wiring harness, electrical terminal connections, and electrical plug-ins for secure, clean electrical contacts, worn or damaged insulation, burnt wires, broken wires, and loose connections.
2. Clean and tighten any loose electrical connections. Repair or replace worn, damaged, burnt, or poorly insulated wiring immediately.

**IMPORTANT:** *Refer to the vendor-supplied literature for recommended maintenance procedures.*

3. Inspect the function of all gauges, voltmeters, switches, and warning lamps on the FPDP. Replace the FPDP if any are not functioning properly.
4. Reinstall the battery cables; attach the negative (-) battery cable last.

### 5.4.2 Turbocharger mounting nuts

As shown in [Figure 5-3](#), check the turbocharger mounting nuts and torque the mounting nuts to the recommended torque value. Refer to the [torque tables](#).

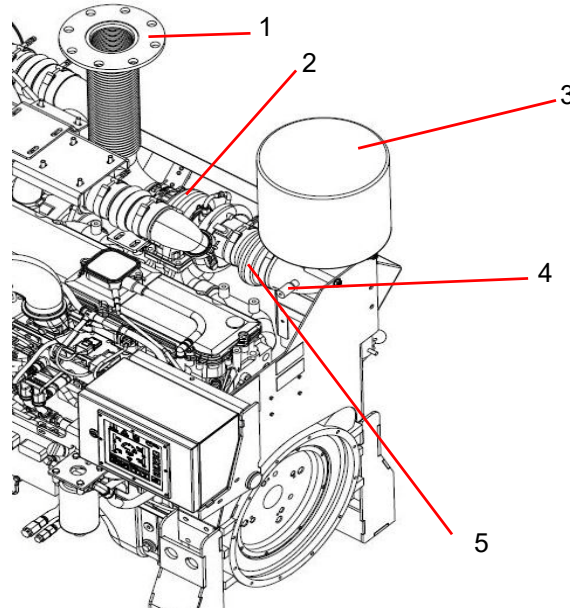

1. Exhaust flex connection
2. Turbocharger
3. Air cleaner assembly (intake)
4. Air cleaner service indicator
5. Air cleaner piping

**Figure 5-3 Typical turbocharger**

### 5.4.3 Engine supports

**CAUTION**

***Loose engine mount bolts or damaged brackets can cause engine misalignment or excessive vibration. These conditions can cause engine or pump damage.***

Refer to [Figure 2-2](#) and [Figure 2-3](#) for the location of the engine supports and inspect all engine supports for cracks or loose hardware. Check the torque on the engine support mounting capscrews. Torque the engine mounting cap screws to the support bracket. Refer to the [torque tables](#) for recommended torque values.

#### 5.4.4 Fuel pumps and filters

As shown in [Figure 5-4](#), inspect the fuel injection pump mounting nuts (including the support bracket) for loose or damaged hardware. Inspect the fuel line hoses and fuel filters for wear, damage, loose fittings, and leaks. Repair or replace damaged hoses and filters as required.

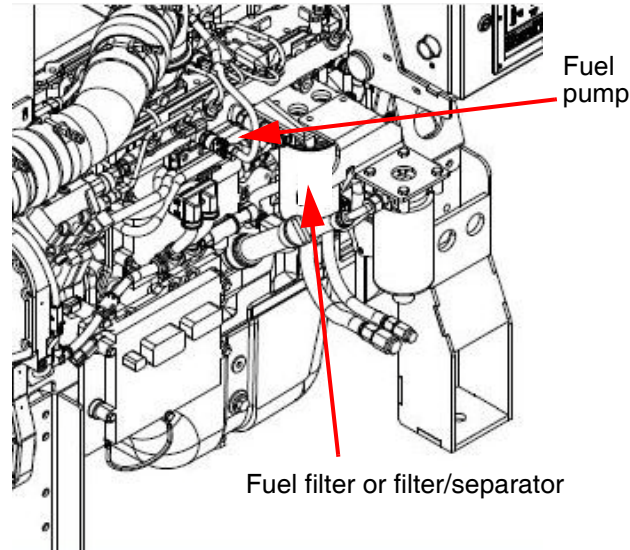

Figure 5-4 Typical fuel pumps and filters

**WARNING**

**Engine fuel is highly flammable and represents an extreme hazard for fire or explosion when exposed to electrical sparks or open flame. Clean up spilled fuel immediately. Keep sources of electrical spark or open flame away from a fuel source.**

**WARNING**

**Do not open the fuel filter/water separator drain valve or dismantle the fuel lines on the high-pressure fuel system with the engine running. High pressure fuel spray from an operating engine can cause serious personal injury or fire hazard.**

To change the fuel filters:

1. Shut off the engine.
2. Close any fuel valves (if equipped) to prevent fuel from draining or siphoning.
3. Clean the area around the fuel filter or fuel/water separator heads.

**NOTE:** Refer to the [engine data sheet](#) for filter replacement recommendations.

4. Remove the spent filter canisters using a filter wrench.
5. Clean the filter mounting head surfaces of sludge buildup and foreign particles. Ensure mating gasket surfaces are clean.
6. Lubricate the gasket seals with clean SAE 15W-40 lubricating oil.

7. Center the filter ring on the threaded mounting nipple. Screw the filter canister onto the mounting flange until the gasket is snug against the mounting flange, then tighten an additional 1/4 turn.
8. Open the fuel supply valves (if equipped).

**CAUTION**

***Mechanical over-tightening can distort the threads or damage the filter element seal.***

9. Press either the CRANK BATT A or CRANK BATT B button to start the engine to allow the fuel to flow through the system.
10. Depress the contactor switch for up to fifteen seconds or until the engine starts. Repeat up to three times, if necessary.

**CAUTION**

***To prevent damage to the starter, do not engage the starting motor more than fifteen seconds. Wait fifteen seconds between each start attempt.***

**IMPORTANT:** *If the engine does not start after three attempts, check the fuel supply system. Absence of blue or white exhaust smoke during cranking indicates no fuel is being delivered.*

**NOTE:** *Engines used in fire pumps or standby service are expected to immediately accelerate from crank to full load.*

#### 5.4.5 Engine oil and filter

Engine oil becomes contaminated and essential oil additives are depleted with use. The amount of contamination is related to the total amount of fuel and oil consumed. Change the oil at least once annually.

**NOTE:** *For composite oil pans, always use a new sealing washer on the oil drain plug. Hold the external locking nut in place while tightening the oil drain plug.*

**IMPORTANT:** *If the engine oil is drained from the oil pan to make an engine repair, new oil must be used.*

**WARNING**

***To reduce the possibility of personal injury, avoid direct contact of hot oil with your skin. Some state and federal agencies have determined that used engine oil can be carcinogenic. Prolonged, repeated contact can cause skin disorders or other bodily injury. Wash thoroughly after contact. Avoid inhalation of vapors and ingestion of used engine oil. Dispose of the oil in accordance with local environmental regulations.***

To change the oil and filter to remove the contaminants suspended in the oil:

1. Operate the engine until the coolant temperature reaches 70 °C (158 °F). Shut the engine off.
2. Place an appropriate container under the oil pan drain plug. Refer to the [engine data sheet](#) for oil pan capacity.
3. Remove the oil drain plug and drain the oil immediately to make sure all the oil and suspended contaminants are removed from the engine.

4. Remove the oil filter (see [Figure 5-5](#)) following these steps:
  - a. Clean the area around the engine oil filter canister. Use a filter wrench to remove the filter.
  - b. Remove and discard the O-ring seal if it has remained attached to the mounting flange. Clean the filter mounting flange with a clean lint-free cloth.
  - c. Apply a light film of 15W-40 lubricating oil to the replacement filter gasket before installing the filter.
5. Fill the oil filter with a high-quality 15W-40 multi-viscosity lubricating oil, such as Premium Blue<sup>®</sup>, or its equivalent.

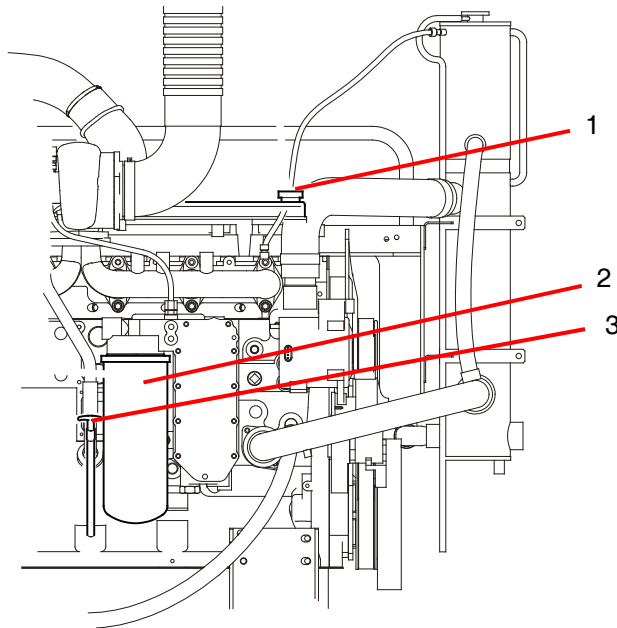

1. Engine oil fill port
2. Engine oil filter
3. Engine oil dipstick

**Figure 5-5 Typical oil filter and oil level dipstick**

6. Center the filter ring on the threaded mounting nipple. Screw the filter canister onto the mounting flange until the gasket is snug against the mounting flange. Then tighten an additional 1/4 turn.

**CAUTION**

***Mechanical over-tightening can distort the threads or damage the filter element seal.***

**NOTE:** Cummins recommends using oil filter replacement parts as outlined in the [engine data sheet](#).

7. Check and clean the oil pan drain plug threads and sealing surface. Install the oil pan drain plug. Torque the plug according to the [torque tables](#).
8. Fill the engine to the proper level with clean, high quality 15W-40 oil at the fill port.

 CAUTION

***If no oil pressure is noted within fifteen seconds after the engine is started, shut down the engine to reduce the possibility of internal damage.***

9. Restart the engine and let it run for approximately one to two minutes.
10. Stop the engine.
11. Wait approximately fifteen minutes to let the oil drain from the upper parts of the engine.
12. Check the oil level again. Add oil as necessary to bring the oil level to the H (high) mark on the dipstick.

#### **5.4.6 Drive shaft**

It is recommended that proper lubrication to drive shafts be completed on a regular schedule according to these steps:

1. Remove the drive shaft guards.
2. Wipe the grease fittings and grease gun nozzle with a clean cloth to avoid contamination.
3. Add grease to the drive shaft universal joint grease fittings (see [Figure 3-2](#)).
4. Wipe excess grease from the grease fittings.

**NOTE:** *Cummins recommends using a good quality semi-synthetic, molybdenum-fortified NLGI #2 lithium complex grease which protects from -47 to 204 °C (-54 to 400 °F).*

### 5.4.7 Coolant pump/alternator belt

On some engine models, the pump and alternator belt drives both the pump and alternator.

To inspect the coolant pump and the alternator belt:

1. Press the AUTO/MAN button on the FPDP to place the fire pump drive engine in MANUAL operation.
2. Disconnect both batteries at their terminals. Remove the negative (-) cable first.
3. Remove the belt guard capscrews and the belt guard. Set aside for re-installation (see [Figure 5-6](#)).

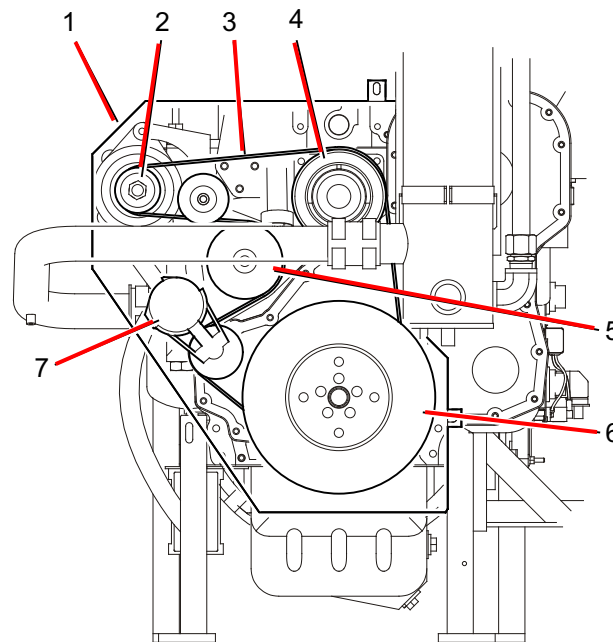

1. Belt guard
2. Alternator pulley
3. Drive belt
4. Idler pulley
5. Coolant pump pulley
6. Balancer pulley
7. Belt tensioner

**Figure 5-6 Coolant pump/alternator belt (typical)**

4. Visually inspect the belt for frayed, worn, missing pieces, or cracked belt surfaces. Check the belt for intersecting cracks.

**CAUTION**

**Belt damage can be caused by: incorrect tension, incorrect size or length, pulley misalignment, incorrect installation, severe operating environment, and/or oil or grease on the belt or pulley.**

**NOTE:** Transverse cracks (across the belt width) are acceptable. Longitudinal cracks (direction of belt length) that intersect with transverse cracks are not acceptable. Replace the belt if it is cracked, frayed, or damaged.

5. If the belt condition is acceptable, check the belt tension. Use the Cummins belt tension gauge (Part Number 3822524) to measure the drive belt tension in the center span of the belt between the idler and alternator pulleys. Ensure that the belt tension is set to the specifications outlined in the Engine Operation manual.

**NOTE:** Belts with glazed or shiny surfaces indicate belt slippage. Correctly installed and tensioned belts will show even pulley and belt wear.

**CAUTION**

**Disconnect the batteries (negative cable first) before performing service on the fire pump drive engine or on any of its controls.**

6. Reinstall the battery cables; attach the negative (-) battery cable last.

#### 5.4.8 Raw water zinc anode

The zinc anode - part number 9750 - (see [Figure 5-7](#)) acts as a raw water filter and must be checked for erosion and replaced, when necessary. If the anode has eroded more than fifty percent, it must be replaced.

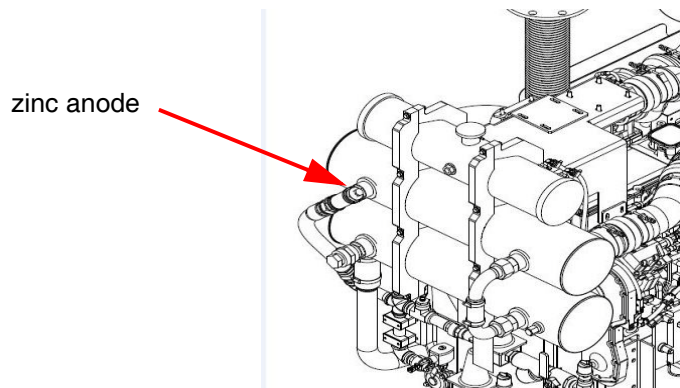

**Figure 5-7 Raw water zinc anode (typical)**

#### 5.4.9 Heat exchanger pressure test

If internal leakage in the heat exchanger is suspected, a heat exchanger pressure test may be performed prior to removal from the engine.

**NOTE:** Use Teflon™ tape or other pipe sealant when installing the test setup in order to prevent leaks.

**NOTE:** The size of fittings required on the water outlets and inlets are listed on the [engine data sheet](#).

To test the heat exchanger pressure:

1. Install an adapter at the cooling water outlet of the heat exchanger.
2. Install a pressure test setup with 689 kPa (100 psi) pressure gauge at the cooling water inlet to the heat exchanger.



3. Apply air pressure at 276 kPa (40 psi).
  - a. Isolate the pressure source and monitor the pressure gauge for five minutes.
  - b. There should be no change in pressure for the duration of the test.
4. After testing, release the pressure. Remove the tubing adapters, plug, and test equipment.
5. If leakage is detected, the heat exchanger must be replaced.

#### 5.4.10 Turbocharger

As shown in [Figure 5-3](#), follow these steps to thoroughly inspect the turbocharger:

1. Visually inspect the air intake filter and piping according to the steps outlined in Section [5.3.2](#).

**NOTE:** *Turbocharged engines must be operated at rated revolutions per minute (RPM) and full load to check maximum intake air restriction.*

**NOTE:** *Cummins recommends using an air cleaner filter element as listed on the [engine data sheet](#).*

**CAUTION**

**Never operate the engine without an air cleaner. Intake air must be filtered to prevent dirt and debris from entering the engine and causing premature wear. Dirt or foreign objects could cause engine damage.**

2. Remove the air intake and exhaust piping from the turbocharger.
3. Inspect the turbocharger turbine wheel for cracks in the housing or turbine blades, missing blades, mechanical binding, eccentric motion, or excessive end-play.
4. Replace the turbocharger if damage, excessive end-play, binding, wear, or eccentric motion is found. Contact a Cummins Authorized Repair Location for replacement.

**IMPORTANT:** *The turbocharger must be removed for replacement or rebuild if the clearance is beyond the limits, the housing is cracked, or the turbine wheel is damaged.*

5. Reinstall the air intake filter and exhaust piping. Tighten the clamps. Torque the loosened clamps to the recommended torque value. Refer to the [torque tables](#).

## 5.5 Every two years

All checks or inspections listed under daily or previous maintenance intervals must also be performed at this time, in addition to those listed under this maintenance interval.

### 5.5.1 Coolant pump

Inspect the coolant pump for eccentric motion, mechanical binding, excessive end play, seal damage, and excessive grease or coolant leakage around the pump shaft.

Replace with a new or rebuilt pre-lubricated unit, as necessary. Contact a Cummins Authorized Repair Location for replacement.

### 5.5.2 Cooling system - heat exchanger

Figure 5-8 illustrates the heat exchanger cooling system. The cooling system must be clean to work properly. If the system shows excessive mineral buildup, particulate matter, scale, oxidation, or oil contamination, drain and flush the cooling system. If the coolant is excessively dirty or is mixed with oil, contact a Cummins Authorized Repair Facility.

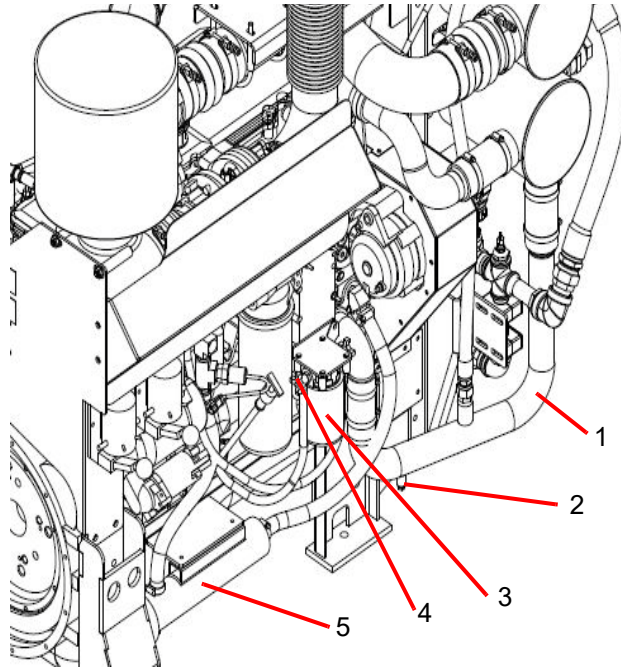

1. Lower coolant hose/tube
2. Coolant drain petcock
3. Coolant filter
4. Coolant filter shut-off valve
5. Engine coolant heater

Figure 5-8 Engine coolant drain - heat exchanger (typical)

**WARNING**

**Do not remove the pressure/fill cap from a hot engine. Shut down the engine and wait until the coolant temperature is below 50 °C (120 °F) before removing the pressure cap. Heated coolant spray or steam can cause severe personal injury.**

1. Disconnect both batteries at their terminals. Remove the negative (-) cable first.
2. Press down, unscrew, and remove the coolant expansion tank pressure/fill cap. The cap must be removed to allow air to vent the cooling system during the draining process.
3. Disconnect the engine coolant heater power supply before draining the cooling system.
4. Place a container that will hold at least 57 liters (15 gallons) of liquid under the coolant drain valve.
5. Ensure that the coolant filter shut-off valves are OPEN.
6. Open the drain petcock on the lower coolant tube, allowing the coolant to drain into the waste container.

7. When the system is empty, move the container under the engine coolant heater.
8. Disconnect either end of the engine heater coolant hose and drain the engine heater.

**CAUTION**

**Coolant is toxic. Avoid prolonged and repeated skin contact with used antifreeze - wash thoroughly after contact. Prolonged, repeated contact can cause skin disorders. Dispose of waste antifreeze in accordance with local environmental regulations.**

9. Flush with clean fresh water or heavy-duty heat exchanger cleaner. Follow the manufacturer's directions on the product container.

**NOTE:** *Some cooling system cleaners or commercial solvents require a soapy water rinse after use. Follow the directions on the cleaning solution or solvent.*

**CAUTION**

**Over-concentration of antifreeze or use of high-silicate antifreeze can damage the engine. Do not use more than 50% antifreeze in the mixture unless additional freeze protection is required. Antifreeze at 68% concentration provides the maximum freeze protection, and must never be exceeded under any condition. Antifreeze protection decreases above 68%.**

10. When the flushing water has fully drained, use a filter wrench to remove the water coolant filter from the filter housing.
  - a. Clean the filter housing gasket mount of dirt buildup, oxidation, or particulate matter with a clean cloth.
  - b. Coat the replacement filter gasket with a light coating of 15W-40 lubrication oil.
11. Center the filter ring on the threaded mounting nipple. Screw the filter canister onto the mounting flange until the gasket is snug against the mounting flange, then tighten an additional 1/4 turn. If using a soapy water solution, flush again with clear water. Allow time for the water to fully drain.

**CAUTION**

**Mechanical over-tightening can distort the threads or damage the filter element seal.**

**NOTE:** *Recommendations on filter replacements and fill rates can be found on the [Engine Data Sheet](#).*

12. Reconnect the engine heater coolant hose and close the drain petcock on the lower coolant tube.

**NOTE:** *During filling, air must be vented from the engine coolant passages. The air vents through the coolant filler port. The fill rate can be found in the [Engine Data Sheet](#).*

13. Fill the coolant tanks with the proper antifreeze. Use a mixture of 50% water and 50% ethylene-glycol base or propylene-glycol antifreeze (or pre-mixed solution) to protect the engine to -37 °C (-34 °F) year-around.

**CAUTION**

**Use soft or distilled water in the coolant mixture. Contaminants in hard water neutralize the corrosion inhibitor components. Water must not exceed 300 ppm hardness or contain more than 100 ppm of either chloride or sulfate.**

**CAUTION**

**Never use a sealing additive to stop leaks in the cooling system. This can result in cooling system blockage or restricted coolant flow, causing the engine to overheat.**

**NOTE:** Cummins recommends using Fleetguard® ES COMPLEAT™ Ethylene-Glycol (EG) or Fleetguard® Propylene-Glycol (PG) Plus™ Antifreeze/Coolants. Both products are available in concentrated or pre-mixed formulations. Use a 50% concentration level (40% to 60% range) of ethylene-glycol or propylene-glycol and Supplemental Coolant Additive (SCA) required for wet-sleeved engines in most climates. Contact your local Cummins Authorized Repair Location for additional information.

Ethylene-Glycol	Propylene-Glycol
40% = -23° C (-10° F)	40% = -21° C (-6° F)
50% = -37° C (-34° F)	50% = -33° C (-27° F)
60% = -54° C (-65° F)	60% = -54° C (-65° F)
68% = -71° C (-96° F)	68% = -63° C (-82° F)

**CAUTION**

**The system must be filled properly to prevent air locks. During filling, air must be vented from the engine coolant passages.**

14. Check the condition of the pressure/fill cap.
  - a. If the pressure/fill cap seal is worn, damaged, missing, or the pressure spring is damaged or shows signs of sticking, replace the filler cap.
  - b. Re-install the expansion tank fill cap.
15. Re-install the heater wiring.
16. Reinstall the battery cables; attach the negative (-) battery cable last.
17. Operate the engine until it reaches a temperature of 82 °C (180 °F), and check for coolant leaks.
18. Ensure that the coolant level is just below the fill neck and that the coolant heater is reconnected.

### 5.6 Every four years

All maintenance checks and inspections listed in previous maintenance intervals must also be performed at this time.

Cummins recommends performing maintenance on valve lash settings.

**CAUTION**

**Disconnect both batteries (negative cable first) before performing service on the fire pump drive engine or on any of its controls. Wear safety glasses when disconnecting batteries!**

**CAUTION**

**Valve lash maintenance should be performed by a skilled technician. Improper maintenance can damage the engine or cause severe personal injury. Contact your local Cummins Authorized Repair Location before performing any extensive maintenance.**

### 5.6.1 Coolant thermostat removal/installation

The thermostat regulates the temperature of the engine coolant circulating through the engine cooling system. Refer to the engine manual for complete instructions.

**CAUTION**

**Always use the correct thermostat, and never operate the engine without a thermostat installed. The engine can overheat if operated without a thermostat because the path of least resistance for the coolant is through the bypass to the pump inlet.**

1. As shown in [Figure 5-9](#), remove the upper coolant hose clamps and upper coolant hose at the thermostat housing.

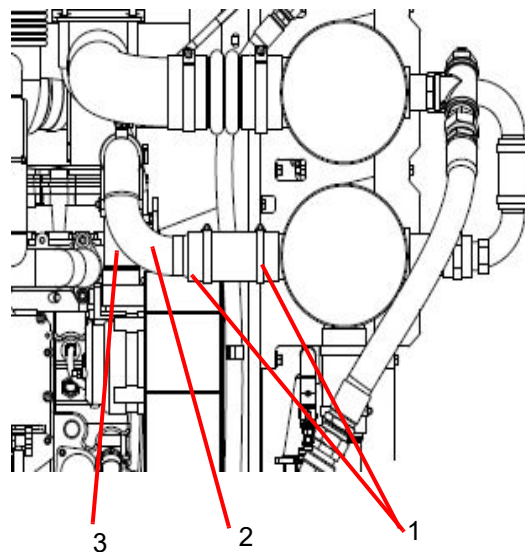

1. Hose clamps
2. Upper coolant hose
3. Thermostat housing

**Figure 5-9 Typical thermostat housing**

2. Remove the (2) thermostat housing flange cap screws and the thermostat flange.
3. Remove the thermostat and gasket from the housing.
4. Clean the housing flange faces of dirt buildup, oxidation, and sludge.
5. If still in good condition, re-install the thermostat in the housing.

**IMPORTANT:** *Inspect the seal on the thermostat housing flange surface and - if damaged or cracked - apply a new seal.*

**NOTE:** *Recommendations on thermostat replacement components can be found on the [engine data sheet](#).*

6. Replace the thermostat flange and cap screws.

### 5.6.2 Coolant pump/alternator belt replacement

Replace the coolant pump/alternator belt if it is cracked, frayed, or has pieces of material missing.

1. Remove the belt guard.
2. Use a 3/8" drive ratchet or breaker bar to rotate the tensioner arm away from the belt and remove the belt.
3. Check the belt tensioner cap screw torque. For recommended torque values, refer to the [torque tables](#).
4. Check the tensioner arm, pulley, and stops for cracks. If any cracks are noticed, the tensioner must be replaced.
5. Verify that the tensioner arm stop is not in contact with the spring casing stop. If either stop is touching, the tensioner must be replaced.
6. Inspect the tensioner for evidence of the tensioner arm contacting the tensioner cap.
7. If there is evidence of the two areas making contact, the pivot tube bushing has failed and the tensioner must be replaced.
8. Check the tensioner bearing.
9. Rotate the belt tensioner pulley. The pulley should spin freely with no mechanical binding, eccentric motion, or excessive end-play.
10. If the arm rotates with mechanical binding, eccentric movement, or excessive end play, replace the tensioner.
11. Inspect the clearance between the tensioner spring case and the tensioner arm for uneven bearing wear.
12. If the clearance exceeds 3 mm (0.12 in) at any point, the tensioner must be replaced as a complete assembly. Contact a Cummins Authorized Repair Location for replacement.

**NOTE:** *Experience has shown that tensioners generally will show a larger clearance gap near the lower portion of the spring case, resulting in the upper portion rubbing against the tensioner arm. Always replace the belt when a tensioner is replaced.*

13. After checking the torque, use a 3/8" drive ratchet or breaker bar to rotate the tensioner slowly away from the area of belt contact.
14. Install the replacement drive belt.

**CAUTION**

***To prevent pulley or belt damage, do not roll a belt over the pulley or pry it on with a tool. Move the tensioner arm away from the belt area before installing the drive belt.***

15. Check the location of the drive belt on the belt tensioner pulley. The belt should be centered on, or centered close to, the middle of the pulley.
16. Reinstall the belt guard.

**CAUTION**

***Unaligned belts, either too far forward or backward, can cause belt wear, belt roll-off failures or increase uneven tensioner bushing wear.***

# 6 - Troubleshooting

## 6.1 Introduction

The following information is intended as a guide for some common non-technical equipment problems. The first part of this section includes troubleshooting charts that cross-reference the problem, the possible cause, and the solution. The second section includes complete Fault Code charts outlining a numerical listing of fault codes and their descriptions.

Many problems can be resolved using corrective maintenance, adjustment, or minor repair. Refer to the vendor supplied literature, electrical schematics, and mechanical prints for additional information.

For engine-related issues, refer to the engine Operation and Maintenance Manual or contact the Cummins Customer Assistance Center at 1-800-CUMMINS (1-800-286-6467).

**⚠ WARNING**

*The status checks should be performed **ONLY** by a qualified technician. Contact with exposed electrical components could cause extreme personal injury or death.*

**⚠ WARNING**

*Before equipment operation, **ALL** guards, covers, and protective devices **MUST BE** in place and securely fastened. Serious personal injury could result from contact with exposed or moving components.*

**⚠ CAUTION**

***AVOID SERVICING** complex components such as: printed circuit boards, programmable controllers, and ECMs not specifically authorized by Cummins. Contact the Cummins Customer Service Department toll free at 1-800-343-7357 before performing any extensive maintenance.*

**⚠ CAUTION**

*Never climb or stand on the equipment frame, guards, or enclosures. Contact with exposed or moving components can cause personal injury or equipment damage.*

## 6.2 Engine Will Not Start

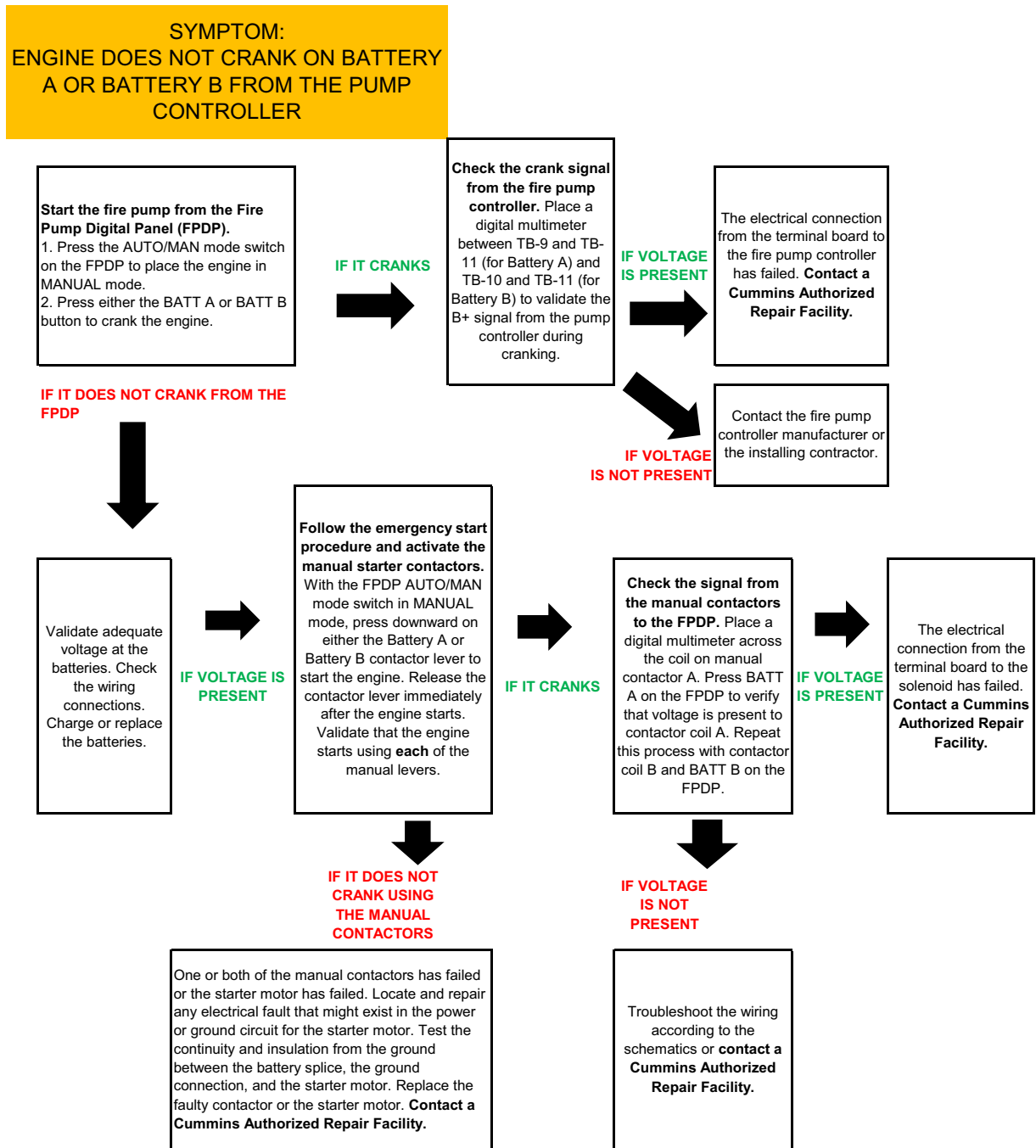



### 6.3 Engine Cranks But Will Not Start

**SYMPTOM:**  
ENGINE CRANKS FROM THE PUMP CONTROLLER, BUT WILL NOT START (NO EXHAUST SMOKE)

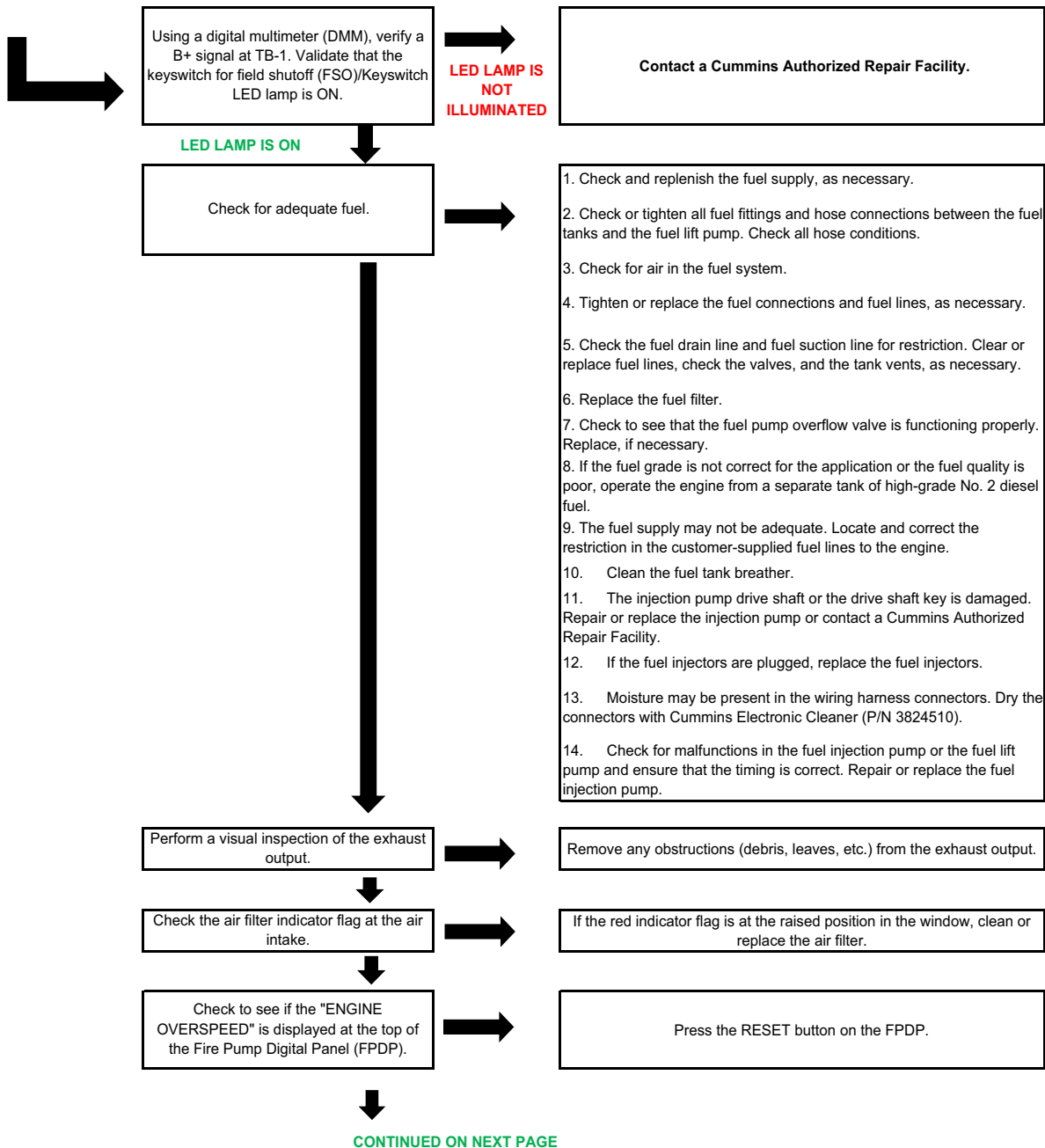

### Engine Cranks But Will Not Start (cont.)

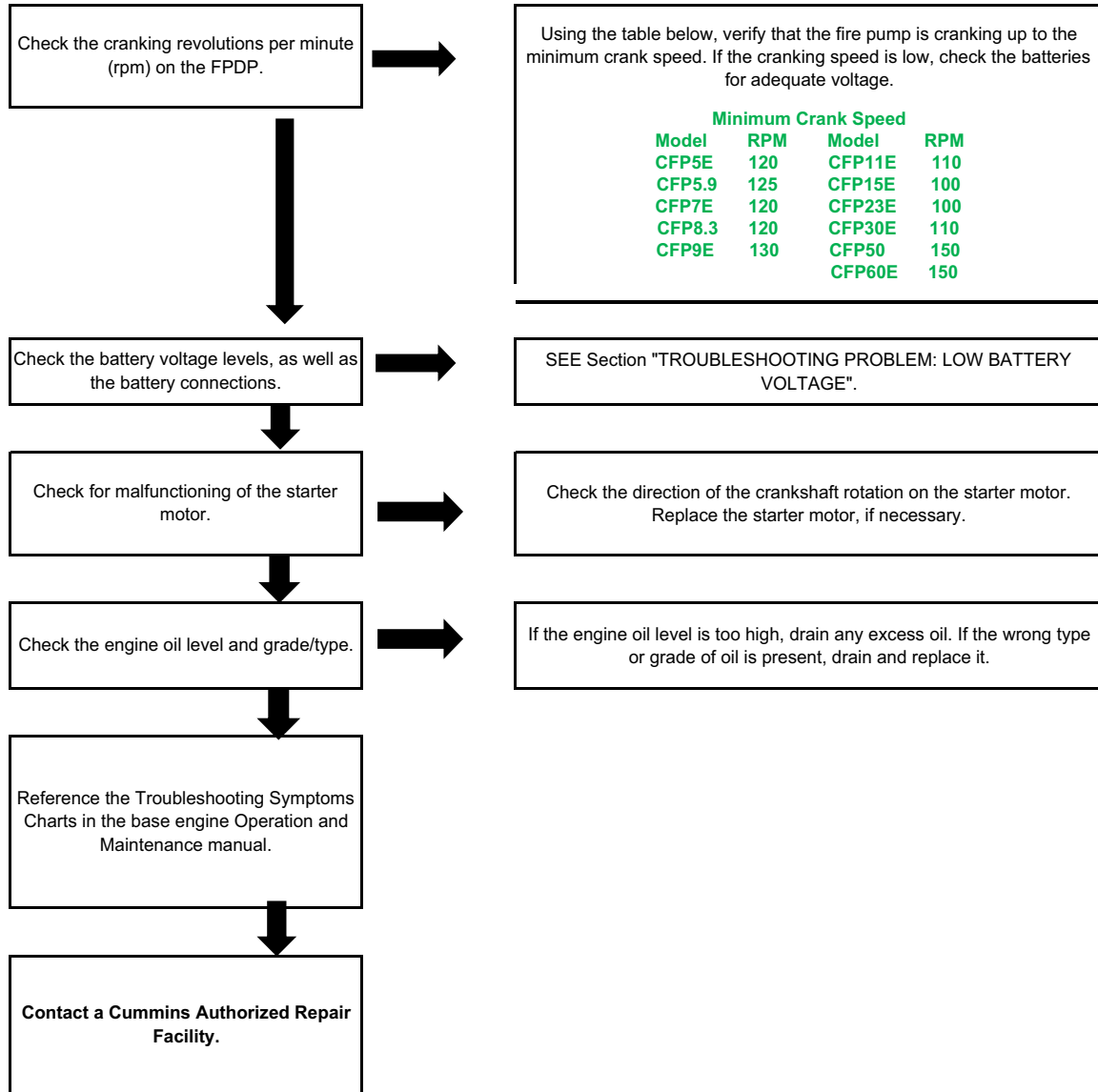

## 6.4 Engine Starts But Continues to Crank

STOP THE ENGINE AT THE FIRE PUMP CONTROLLER (PLACE THE CONTROLLER IN THE OFF POSITION) AND TROUBLESHOOT FROM THE FIRE PUMP DRIVE ENGINE:

PRIOR TO MAKING A SERVICE CALL, PERFORM A VISUAL INSPECTION:

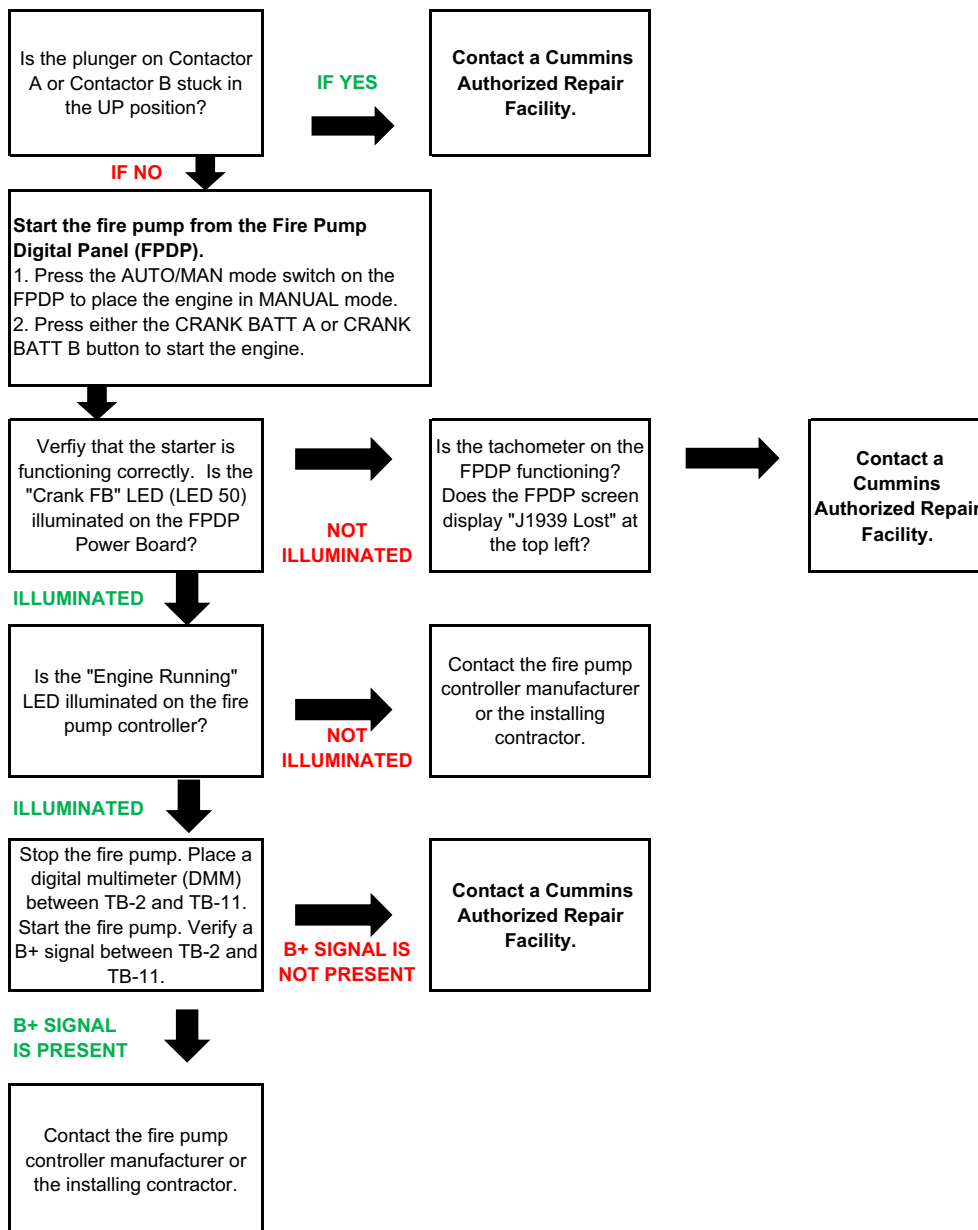

## 6.5 Engine Will Not Stop

TO STOP THE ENGINE:

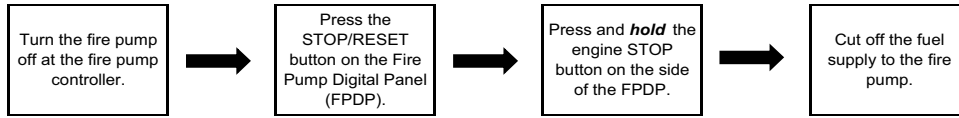

TO TROUBLESHOOT THIS PROBLEM, ONCE THE FIRE PUMP HAS STOPPED:

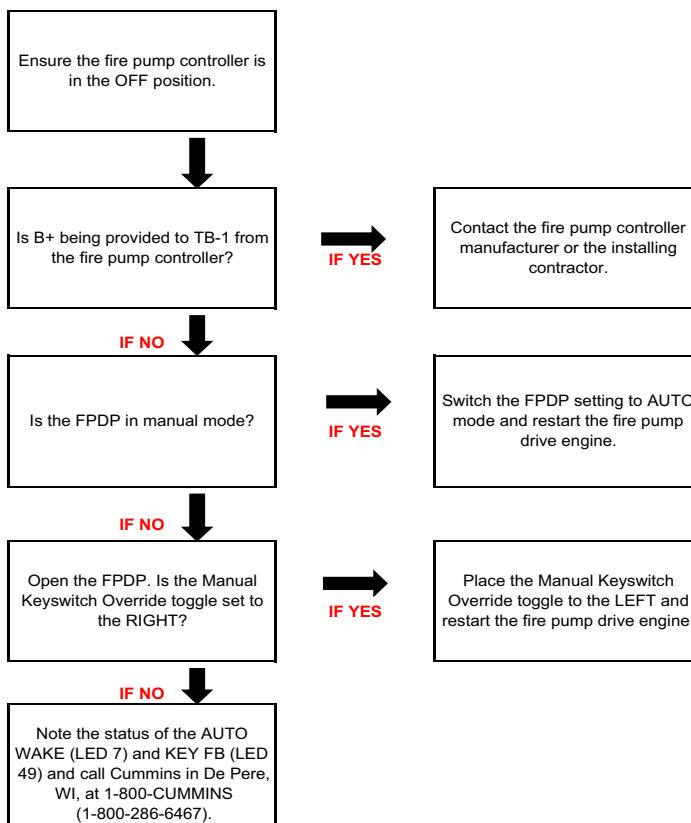

## 6.6 Low Battery Voltage

### PROBLEM: LOW BATTERY VOLTAGE

**SYMPTOM:** The Fire Pump Digital Panel (FPDP) will momentarily "blink" upon starting or the fire pump drive engine is slow to crank. There is a high probability that the engine will not start.

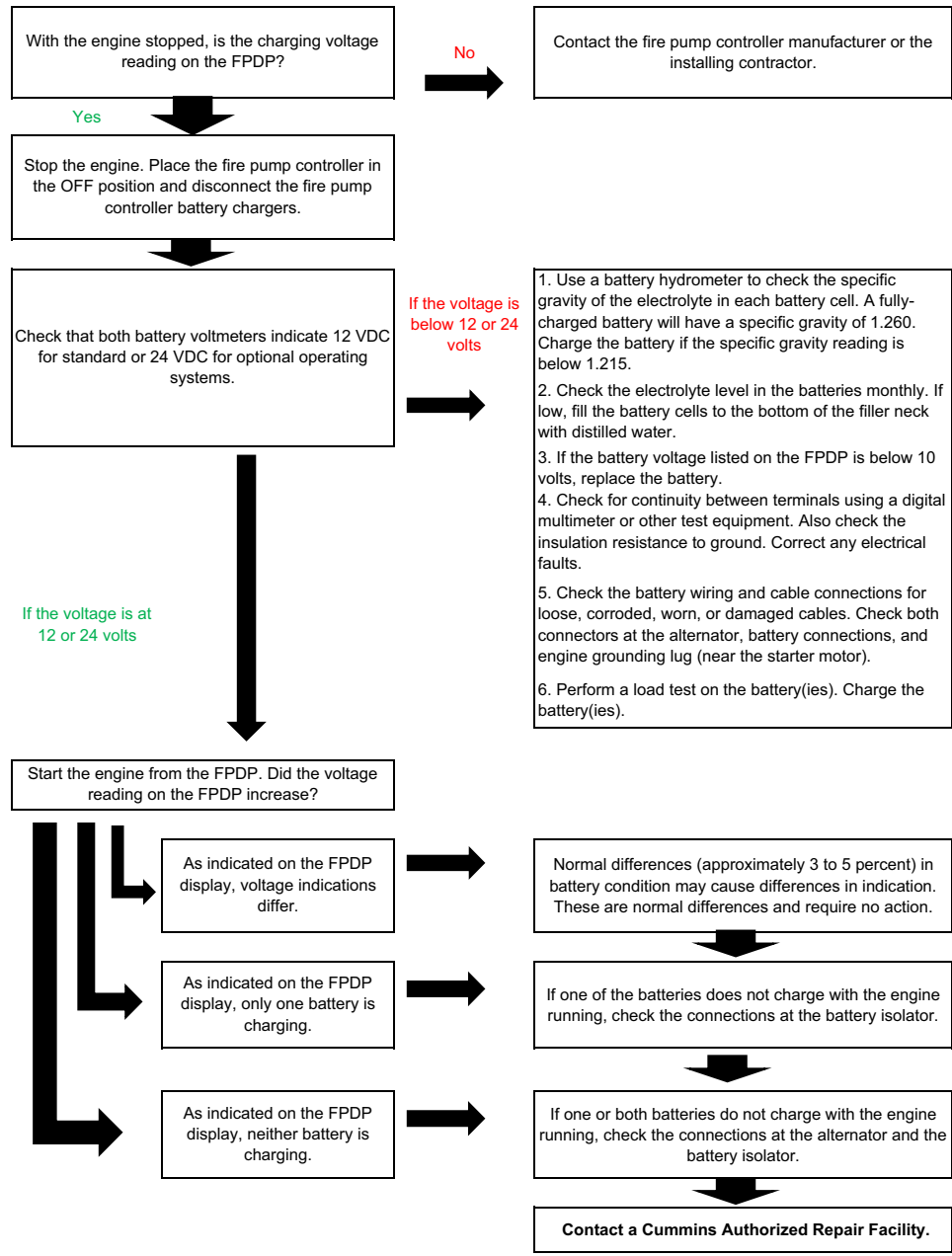

## **6.7 Fault Code Charts - CFP5E/EVS, CFP7E/EVS, CFP9E/EVS, and CFP9E HHP**

The following tables specify the fault codes and their meanings for the CFP5E/EVS, CFP7E/EVS, CFP9E/EVS, and CFP9E HHP model fire pump drive engines:

CUMMINS FAULT CODE	SPN	FMI	LAMP COLOR	CUMMINS DESCRIPTION
111	629	12	Red	Engine Control Module Critical internal failure - Bad intelligent Device or Component
115	612	2	Red	Engine Speed/Position Sensor Circuit lost both of two signals from the magnetic pickup sensor - Data Erratic
122	102	3	Yellow	Intake Manifold Pressure Sensor Circuit - Voltage Above Normal, or Shorted to High Source.
123	102	4	Yellow	Intake Manifold Pressure Sensor Circuit - Voltage Below Normal, or Shorted to Low Source
124	102	16	Yellow	Intake Manifold 1 Pressure - Data Valid but Above Normal Operational Range - Moderately Severe Level
131	91	3	Red	Accelerator Pedal or Lever Position Sensor Circuit - Voltage Above Normal, or Shorted to High Source
132	91	4	Red	Accelerator Pedal or Lever Position Sensor Circuit - Voltage Below Normal, or Shorted to Low Source
133	974	3	Red	Remote Accelerator Pedal or Level Position Sensor Circuit - Voltage Above Normal, or Shorted to High Source
134	974	4	Red	Remote Accelerator Pedal or Level Position Sensor Circuit - Voltage Below Normal, or Shorted to Low Source
135	100	3	Yellow	Oil Pressure Sensor Circuit - Voltage Above Normal, or Shorted to High Source
141	100	4	Yellow	Oil Pressure Sensor Circuit - Voltage Below Normal, or Shorted to Low Source
143	100	18	Yellow	Oil Pressure Low - Data Valid but Below Normal Operational Range - Moderately Severe Level
144	110	3	Yellow	Coolant Temperature Sensor Circuit - Voltage Above Normal or Shorted to High Source
145	110	4	Yellow	Coolant Temperature Sensor Circuit - Voltage Below Normal or Shorted to Low Source
146	110	16	Yellow	Coolant Temperature High - Data Valid but Above Normal Operational Range - Moderately Severe Level
147	91	1	Red	Accelerator Pedal or Level Position Sensor Circuit - Abnormal Frequency, Pulse Width, or Period
148	91	0	Red	Accelerator Pedal or Level Position Sensor Circuit - Abnormal Frequency, Pulse Width, or Period
151	110	0	Red	Coolant Temperature Low - Data Valid but Above Normal Operational Range - Most Severe Level
153	105	3	Yellow	Intake Manifold Air Temperature Sensor Circuit - Voltage Above Normal, or Shorted to High Source
154	105	4	Yellow	Intake Manifold Air Temperature Sensor Circuit - Voltage Below Normal, or Shorted to Low Source
155	105	0	Red	Intake Manifold Air Temperature High - Data Valid but Above Normal Operational Range - Most Severe Level
187	3510	4	Yellow	Sensor Supply Voltage #2 Circuit - Voltage Below Normal, or Shorted to Low Source
195	111	3	Yellow	Coolant Level Sensor Circuit - Voltage Above Normal, or Shorted to High Source
196	111	4	Yellow	Coolant Level Sensor Circuit - Voltage Below Normal, or Shorted to Low Source
197	111	18	Yellow	Coolant Level - Data Valid but Below Normal Operational Range - Moderately Severe Level

CUMMINS FAULT CODE	SPN	FMI	LAMP COLOR	CUMMINS DESCRIPTION
199	1661	4	Yellow	Engine Automatic Start Lamp Driver Circuit - Voltage Above Normal, or Shorted to High Source
211	1484	31		Additional Auxiliary Diagnostic Codes logged - Condition Exists
212	175	3	Yellow	Engine Oil Temperature Sensor #1 Circuit - Voltage Above Normal, or Shorted to High Source
213	175	4	Yellow	Engine Oil Temperature Sensor #1 Circuit - Voltage Below Normal, or Shorted to Low Source
214	175	0	Red	Engine Oil Temperature - Data Valid but Above Normal Operational Range - Most Severe Level
221	108	3	Yellow	Barometric Pressure Sensor Circuit - Voltage Above Normal, or Shorted to High Source
222	108	4	Yellow	Barometric Pressure Sensor Circuit - Voltage Below Normal, or Shorted to Low Source
227	3510	3	Yellow	Sensor Supply Voltage #2 Circuit - Voltage Above Normal, or Shorted to High Source
231	109	3	Yellow	Coolant Pressure Sensor Circuit - Voltage Above Normal, or Shorted to High Source
232	109	4	Yellow	Coolant Pressure Sensor Circuit - Voltage Below Normal, or Shorted to Low Source
233	109	18	Yellow	Coolant Pressure - Data Valid but Below Normal Operational Range - Moderately Severe Level
234	190	0	Red	Engine Speed High - Data Valid but Above Normal Operational Range - Most Severe Level
235	111	1	Red	Coolant Level Low - Data Valid but Below Normal Operational Range - Most Severe Level
237	644	2	Yellow	External Speed Input (Multiple Unit Synchronization) - Data Erratic, Intermittent, or Incorrect
238	3511	4	Yellow	Sensor Supply Voltage #3 Circuit - Voltage Below Normal, or Shorted to Low Source
239	3511	3	Yellow	Sensor Supply Voltage #3 Circuit - Voltage Above Normal, or Shorted to High Source
241	84	2	Yellow	Vehicle Speed Sensor Circuit - Data Erratic, Intermittent, or Incorrect
242	84	10	Yellow	Vehicle Speed Sensor Circuit tampering has been detected - Abnormal Rate of Change
244	623	4	Yellow	Red Stop Lamp Driver Circuit - Voltage Below Normal, or Shorted to Low Source
245	647	4	Yellow	Fan Control Circuit - Voltage Below Normal, or Shorted to Low Source
249	171	3	Yellow	Ambient Air Temperature Sensor Circuit - Voltage Above Normal, or Shorted to High Source
256	171	4	Yellow	Ambient Air Temperature Sensor Circuit - Voltage Below Normal, or Shorted to Low Source
261	174	16	Yellow	Engine Fuel Temperature - Data Valid but Above Normal Operational Range - Moderately Severe Level
263	174	3	Yellow	Engine Fuel Temperature Sensor #1 Circuit - Voltage Above Normal, or Shorted to High Source
265	174	4	Yellow	Engine Fuel Temperature Sensor #1 Circuit - Voltage Below Normal, or Shorted to Low Source
268	94	2	Yellow	Fuel Pressure Sensor Circuit - Data Erratic, Intermittent, or Incorrect
271	1347	4	Yellow	High Fuel Pressure Solenoid Valve Circuit - Voltage Below Normal, or Shorted to Low Source



CUMMINS FAULT CODE	SPN	FMI	LAMP COLOR	CUMMINS DESCRIPTION
272	1347	3	Yellow	High Fuel Pressure Solenoid Valve Circuit - Voltage Above Normal, or Shorted to High Source
281	1347	7	Yellow	High Fuel Pressure Solenoid Valve #1 - Mechanical System Not Responding Properly or Out of Adjustment
284	1043	4	Yellow	Engine Speed/Position Sensor (Crankshaft) Supply Voltage Circuit - Voltage Below Normal, or Shorted to Low Source
285	639	9	Yellow	SAE J1939 Multiplexing PGN Timeout Error - Abnormal Update Rate
286	639	13	Yellow	SAE J1939 Multiplexing Configuration Error - Out of Calibration
287	91	19	Red	SAE J1939 Multiplexing Accelerator Pedal or Level Sensor System Error - Received Network Data in Error
288	974	19	Red	SAE J1939 Multiplexing Remote Accelerator Pedal or Level Data Error - Received Network Data in Error
292	441	14	Red	Auxiliary Temperature Sensor Input #1 - Special Instructions
293	441	3	Yellow	Auxiliary Temperature Sensor Input #1 Circuit - Voltage Above Normal, or Shorted to High Source
294	441	4	Yellow	Auxiliary Temperature Sensor Input #1 Circuit - Voltage Below Normal, or Shorted to Low Source
295	108	2	Yellow	Barometric Pressure Sensor Circuit - Data Erratic, Intermittent, or Incorrect
296	1388	14	Red	Auxiliary Pressure Sensor Input #1 - Special Instructions
297	1388	3	Yellow	Auxiliary Pressure Sensor Input #2 Circuit - Voltage Above Normal, or Shorted to High Source
298	1388	4	Yellow	Auxiliary Pressure Sensor Input #2 Circuit - Voltage Below Normal, or Shorted to Low Source
319	251	2		Real Time Clock Power Interrupt - Data Erratic, Intermittent, or Incorrect
322	651	5	Yellow	Injector Solenoid Cylinder #1 Circuit - Current Below Normal, or Open Circuit
323	655	5	Yellow	Injector Solenoid Cylinder #5 Circuit - Current Below Normal, or Open Circuit
324	653	5	Yellow	Injector Solenoid Cylinder #3 Circuit - Current Below Normal, or Open Circuit
325	656	5	Yellow	Injector Solenoid Cylinder #6 Circuit - Current Below Normal, or Open Circuit
331	652	5	Yellow	Injector Solenoid Cylinder #2 Circuit - Current Below Normal, or Open Circuit
332	654	5	Yellow	Injector Solenoid Cylinder #4 Circuit - Current Below Normal, or Open Circuit
334	110	2	Yellow	Coolant Temperature Sensor Circuit - Data Erratic, Intermittent, or Incorrect
338	1267	3	Yellow	Idle Shutdown Vehicle Accessories Relay Driver Circuit - Voltage Above Normal, or Shorted to High Source
339	1267	4	Yellow	Idle Shutdown Vehicle Accessories Relay Driver Circuit - Voltage Below Normal, or Shorted to Low Source
341	630	2	Yellow	Engine Control Module data lost - Data Erratic, Intermittent, or Incorrect
342	630	13	Red	Electronic Calibration Code Incompatibility - Out of Calibration
343	629	12	Yellow	Engine Control Module Warning internal hardware failure - Bad intelligent Device or Component
349	191	16	Yellow	Transmission Output Shaft Speed - Data Valid but Above Normal Operational Range - Moderately Severe Level
351	627	12	Yellow	Injector Power Supply - Bad Intelligent Device or Component

CUMMINS FAULT CODE	SPN	FMI	LAMP COLOR	CUMMINS DESCRIPTION
352	3509	4	Yellow	Sensor Supply Voltage #1 Circuit - Voltage Below Normal, or Shorted to Low Source
386	3509	3	Yellow	Sensor Supply Voltage #1 Circuit - Voltage Above Normal, or Shorted to High Source
415	100	1	Red	Oil Pressure Low - Data Valid but Below Normal Operational Range - Most Severe Level
418	97	15		Water in Fuel Indicator High - Data Valid but Above Normal Operational Range - Least Severe Level
422	111	2	Yellow	Coolant Level - Data Erratic, Intermittent, or Incorrect
425	175	2	Yellow	Engine Oil Temperature - Data Erratic, Intermittent, or Incorrect
428	97	3	Yellow	Water in Fuel Sensor Circuit - Voltage Above Normal, or Shorted to High Source
429	97	4	Yellow	Water in Fuel Sensor Circuit - Voltage Below Normal, or Shorted to Low Source
431	558	2	Yellow	Accelerator Pedal or Lever Idle Validation Circuit - Data Erratic, Intermittent, or Incorrect
432	558	13	Red	Accelerator Pedal or Lever Idle Validation Circuit - Out of Calibration
435	100	2	Yellow	Oil Pressure Sensor Circuit - Data Erratic, Intermittent, or Incorrect
441	168	18	Yellow	Battery #1 Voltage Low - Data Valid but Below Normal Operational Range - Moderately Severe Level
442	168	16	Yellow	Battery #1 Voltage High - Data Valid but Above Normal Operational Range - Moderately Severe Level
449	157	0	Red	Fuel Pressure High - Data Valid but Above Normal Operational Range - Moderately Severe Level
451	157	3	Yellow	Injector Metering Rail #1 Pressure Sensor Circuit - Voltage Above Normal, or Shorted to High Source
452	157	4	Yellow	Injector Metering Rail #1 Pressure Sensor Circuit - Voltage Below Normal, or Shorted to Low Source
488	105	16	Yellow	Intake Manifold #1 Temperature - Data Valid but Above Normal Operational Range - Moderately Severe Level
489	191	18	Yellow	Transmission Output Shaft Speed - Data Valid but Below Normal Operational Range - Moderately Severe Level
497	1377	2	Yellow	Multiple Unit Synchronization Switch Circuit - Data Erratic, Intermittent, or Incorrect
523	611	2	Yellow	OEM Intermediate (PTO) Speed switch Validation - Data Erratic, Intermittent, or Incorrect
527	702	3	Yellow	Auxiliary Input/Output #2 Circuit - Voltage Above Normal, or Shorted to High Source
528	93	2	Yellow	Auxiliary Alternate Torque Validation Switch - Data Erratic, Intermittent, or Incorrect
529	703	3	Yellow	Auxiliary Input/Output #3 Circuit - Voltage Above Normal, or Shorted to High Source
546	94	3	Yellow	Fuel Delivery Pressure Sensor Circuit - Voltage Above Normal, or Shorted to High Source
547	94	4	Yellow	Fuel Delivery Pressure Sensor Circuit - Voltage Below Normal, or Shorted to Low Source
551	558	4	Yellow	Accelerator Pedal or Lever Idle Validation Circuit - Voltage Below Normal, or Shorted to Low Source
553	157	16	Yellow	Injector Metering Rail #1 Pressure High - Data Valid but Above Normal Operational Range - Moderately Severe Level
554	157	2	Yellow	Fuel Pressure Sensor Error - Data Erratic, Intermittent, or Incorrect

CUMMINS FAULT CODE	SPN	FMI	LAMP COLOR	CUMMINS DESCRIPTION
559	157	18	Yellow	Injector Metering Rail #1 Pressure High - Data Valid but Below Normal Operational Range - Moderately Severe Level
584	677	3	Yellow	Starter Relay Circuit - Voltage Above Normal, or Shorted to High Source
585	677	4	Yellow	Starter Relay Circuit - Voltage Below Normal, or Shorted to Low Source
595	103	16	Yellow	Turbocharger #1 Speed High - Data Valid but Above Normal Operational Range - Moderately Severe Level
596	167	16	Yellow	Electrical Charging System Voltage High - Data Valid but Above Normal Operational Range - Moderately Severe Level
597	167	18	Yellow	Electrical Charging System Voltage High - Data Valid but Below Normal Operational Range - Moderately Severe Level
598	167	1	Red	Electrical Charging System Voltage High - Data Valid but Below Normal Operational Range - Most Severe Level
599	640	14	Red	Auxiliary Commanded Dual Output Shutdown - Special Instructions
649	1378	31		Change Lubricating Oil and Filter - Condition Exists
687	103	18	Yellow	Turbocharger #1 Speed Low - Data Valid but Below Normal Operational Range - Moderately Severe Level
689	190	2	Yellow	Primary Engine Speed Sensor Error - Data Erratic, Intermittent, or Incorrect
691	1172	3	Yellow	Turbocharger #1 Compressor Inlet Temperature Sensor Circuit - Voltage Above Normal, or Shorted to High Source
692	1172	4	Yellow	Turbocharger #1 Compressor Inlet Temperature Sensor Circuit - Voltage Below Normal, or Shorted to Low Source
697	1136	3	Yellow	ECM Internal Temperature Sensor Circuit - Voltage Above Normal, or Shorted to High Source
698	1136	4	Yellow	ECM Internal Temperature Sensor Circuit - Voltage Below Normal, or Shorted to Low Source
719	22	3	Yellow	Extended Crankcase Blow-by Pressure Circuit - Voltage Above Normal, or Shorted to High Source
729	22	4	Yellow	Extended Crankcase Blow-by Pressure Circuit - Voltage Below Normal, or Shorted to Low Source
731	723	7	Yellow	Engine Speed/Position #2 mechanical misalignment between camshaft and crankshaft sensors
757	2802	31	Yellow	Electronic Control Module data lost - Condition Exists
778	723	2	Yellow	Engine Speed Sensor (Camshaft) Error - Data Erratic, Intermittent, or Incorrect
779	703	11	Yellow	Warning Auxiliary Equipment Sensor Input #3 (OEM Switch) - Root Cause Not Known
951	166	2		Cylinder Power Imbalance Between Cylinders - Data Erratic, Intermittent, or Incorrect
1117	627	2		Power Lost With Ignition On - Data Erratic, Intermittent, or Incorrect
1139	651	7	Yellow	Injector Cylinder #1 - Mechanical System Not Responding Properly or Out of Adjustment
1141	652	7	Yellow	Injector Cylinder #2 - Mechanical System Not Responding Properly or Out of Adjustment
1142	653	7	Yellow	Injector Cylinder #3 - Mechanical System Not Responding Properly or Out of Adjustment
1143	654	7	Yellow	Injector Cylinder #4 - Mechanical System Not Responding Properly or Out of Adjustment
1144	655	7	Yellow	Injector Cylinder #5 - Mechanical System Not Responding Properly or Out of Adjustment

Troubleshooting

CUMMINS FAULT CODE	SPN	FMI	LAMP COLOR	CUMMINS DESCRIPTION
1145	656	7	Yellow	Injector Cylinder #6 - Mechanical System Not Responding Properly or Out of Adjustment
1239	2623	3	Yellow	Accelerator Pedal or Lever Position Sensor #2 Circuit - Voltage Above Normal, or Shorted to High Source
1241	2623	4	Yellow	Accelerator Pedal or Lever Position Sensor #2 Circuit - Voltage Below Normal, or Shorted to Low Source
1242	91	2	Red	Accelerator Pedal or Lever Position Sensor #1 and #2 - Data Erratic, Intermittent, or Incorrect
1256	1563	2	Yellow	Control Module Identification Input State Error - Data Erratic, Intermittent, or Incorrect
1257	1563	2	Red	Control Module Identification Input State Error - Data Erratic, Intermittent, or Incorrect
1852	97	16	Yellow	Water in Fuel Indicator - Data Valid but Above Normal Operational Range - Moderately Severe Level
1911	157	0	Yellow	Injector Metering Rail #1 Pressure - Data Valid but Above Normal Operational Range - Most Severe Level
2111	52	3	Yellow	Coolant Temperature #2 Sensor Circuit - Voltage Above Normal, or Shorted to High Source
2112	52	4	Yellow	Coolant Temperature #2 Sensor Circuit - Voltage Below Normal, or Shorted to Low Source
2113	52	16	Yellow	Coolant Temperature #2 - Data Valid but Above Normal Operational Range - Moderately Severe Level
2114	52	0	Red	Coolant Temperature #2 - Data Valid but Above Normal Operational Range - Most Severe Level
2115	2981	3	Yellow	Coolant Pressure #2 Circuit - Voltage Above Normal, or Shorted to High Source
2116	2981	4	Yellow	Coolant Pressure #2 Circuit - Voltage Below Normal, or Shorted to Low Source
2117	2981	18	Yellow	Coolant Pressure #2 - Data Valid but Below Normal Operational Range - Moderately Severe Level
2182	1072	3	Yellow	Engine Brake Actuator Driver #1 Circuit - Voltage Above Normal, or Shorted to High Source
2183	1072	4	Yellow	Engine Brake Actuator Driver #1 Circuit - Voltage Below Normal, or Shorted to Low Source
2185	3512	3	Yellow	Sensor Supply Voltage #4 Circuit - Voltage Above Normal, or Shorted to High Source
2186	3512	4	Yellow	Sensor Supply Voltage #4 Circuit - Voltage Below Normal, or Shorted to Low Source
2195	703	14	Red	Auxiliary Equipment Sensor Input #3 Engine Protection Critical - Special Instructions
2215	94	18	Yellow	Fuel Pump Delivery Pressure - Data Valid but Below Normal Operational Range - Moderately Severe Level
2216	94	1	Yellow	Fuel Pump Delivery Pressure - Data Valid but Above Normal Operational Range - Moderately Severe Level
2217	630	31	Yellow	ECM Program Memory (RAM) Corruption - Condition Exists
2249	157	1	Yellow	Injector Metering Rail #1 Pressure - Data Valid but Below Normal Operational Range - Most Severe Level
2261	94	15		Fuel Pump Delivery Pressure - Data Valid but Above Normal Operational Range - Least Severe Level
2262	94	17		Fuel Pump Delivery Pressure - Data Valid but Below Normal Operational Range - Least Severe Level

CUMMINS FAULT CODE	SPN	FMI	LAMP COLOR	CUMMINS DESCRIPTION
2263	1800	16	Yellow	Battery Temperature - Data Valid but Above Normal Operational Range - Moderately Severe Level
2264	1800	18	Yellow	Battery Temperature - Data Valid but Below Normal Operational Range - Moderately Severe Level
2265	1075	3	Yellow	Fuel Priming Pump Control Signal Circuit - Voltage Above Normal, or Shorted to High Source
2266	1075	4	Yellow	Fuel Priming Pump Control Signal Circuit - Voltage Below Normal, or Shorted to Low Source
2292	611	16	Yellow	Fuel Inlet Meter Device - Data Valid but Above Normal Operational Range - Moderately Severe Level
2293	611	18	Yellow	Fuel Inlet Meter Device flow demand lower than expected - Data Valid but Below Normal Operational Range
2311	633	31	Yellow	Fueling Actuator #1 Circuit Error - Condition Exists
2321	190	2		Engine Speed / Position Sensor #1 - Data Erratic, Intermittent, or Incorrect
2322	723	2		Engine Speed / Position Sensor #2 - Data Erratic, Intermittent, or Incorrect
2345	103	10	Yellow	Turbocharger speed invalid rate of change detected - Abnormal Rate of Change
2346	2789	15		Turbocharger Turbine Inlet Temperature (Calculated) - Data Valid but Above Normal Operational Range
2347	2790	15		Turbocharger Turbine Outlet Temperature (Calculated) - Data Valid but Above Normal Operational Range
2363	1073	4	Yellow	Engine Brake Actuator Circuit #2 - Voltage Below Normal, or Shorted to Low Source
2365	1112	4	Yellow	Engine Brake Actuator Driver Output #3 Circuit - Voltage Below Normal, or Shorted to Low Source
2367	1073	3	Yellow	Engine Brake Actuator Circuit #2 - Voltage Above Normal, or Shorted to High Source
2368	1112	3	Yellow	Engine Brake Actuator Driver Output #3 Circuit - Voltage Above Normal, or Shorted to High Source
2372	95	16	Yellow	Fuel Filter Differential Pressure - Data Valid but Above Normal Operational Range - Moderately Severe Level
2373	1209	3	Yellow	Exhaust Gas Pressure Sensor Circuit - Voltage Above Normal, or Shorted to High Source
2374	1209	4	Yellow	Exhaust Gas Pressure Sensor Circuit - Voltage Below Normal, or Shorted to Low Source
2375	412	3	Yellow	Exhaust Gas Recirculation Temperature Sensor Circuit - Voltage Above Normal, or Shorted to High Source
2376	412	4	Yellow	Exhaust Gas Recirculation Temperature Sensor Circuit - Voltage Below Normal, or Shorted to Low Source
2377	647	3	Yellow	Fan Control Circuit - Voltage Above Normal, or Shorted to High Source
2425	730	4		Intake Air Heater #2 Circuit - Voltage Below Normal, or Shorted to Low Source
2426	730	3		Intake Air Heater #2 Circuit - Voltage Above Normal, or Shorted to High Source
2555	729	3	Yellow	Intake Air Heater #1 Circuit - Voltage Above Normal, or Shorted to High Source
2556	729	4	Yellow	Intake Air Heater #1 Circuit - Voltage Below Normal, or Shorted to Low Source

Troubleshooting

---

<b>CUMMINS FAULT CODE</b>	<b>SPN</b>	<b>FMI</b>	<b>LAMP COLOR</b>	<b>CUMMINS DESCRIPTION</b>
2557	697	3	Yellow	Auxiliary PWM Driver #1 - Voltage Above Normal, or Shorted to High Source
2558	697	4	Yellow	Auxiliary PWM Driver #1 - Voltage Below Normal, or Shorted to Low Source
2963	110	15		Engine Coolant Temperature High - Data Valid but Above Normal Operational Range - Lease Severe Level
2973	102	2	Yellow	Intake Manifold Pressure Sensor Circuit - Data Erratic, Intermittent, or Incorrect

# 7 - Component parts and assemblies

## 7.1 Repairs and technical service

Personnel at Cummins Authorized Repair Locations can assist you with the correct operation and service of your engine. Cummins has a worldwide service network of more than 5,000 Distributors and Dealers who have been trained to provide sound advice, expert service, and complete parts support. Check the telephone directory yellow pages or refer to the directory in this section for the nearest Cummins Authorized Repair Location. Outside of North America, contact your regional office. Telephone numbers and addresses are listed in the International Directory.

If assistance is required, call toll-free: 1-800-CUMMINS. Includes all 50 states, Bermuda, Puerto Rico, Virgin Islands, and the Bahamas. The Cummins Customer Assistance Center provides 24-hour assistance to aid in technical and emergency service when a Cummins Authorized Repair Location cannot be reached or is unable to resolve an issue with a Cummins product.

Refer also to the Cummins Inc. website at [cummins.com](http://cummins.com).

## 7.2 Recommended spare parts inventory

To minimize downtime and increase productivity, Cummins Inc. recommends maintaining a stock of spare parts critical to uninterrupted engine operation. Shipping costs can be lower using ground transportation rather than overnight or next day air freight. For this reason, Cummins Inc. can provide a list of recommended spare parts. Contact a Cummins Authorized Repair Location for additional information.

## 7.3 Ordering parts

Replacement parts for the Cummins Inc. equipment are manufactured to the same quality standards and specifications as the original equipment. Unapproved substitution may result in poor performance, reduced service life, lost production, or unsafe operation.

Cummins Inc. relies on the best and most cost effective shipping methods, unless specific instructions or requirements are requested by the customer. When ordering parts, please be prepared to provide the following information:

- Model and serial number
- Part description by name
- Quantity required
- Purchase order number

**NOTE:** *A purchase order number is desirable, even if the part(s) are supplied on a Returned Goods Authorization (RGA) issue number. A purchase order number helps Cummins and its customer track the parts and necessary credits.*

## 7.4 Engine data and torque values

The following pages outline applicable reference material that represents the engine data for the CFP5E and all its ratings at the time of this printing. For a complete, up-to-date, Model Specification Sheet, refer to cummins.com.

### Air induction system

Maximum temperature rise between ambient air and engine air inlet	30 °F (16.7 °C)
Maximum inlet restriction with dirty filter	25 in. H <sub>2</sub> O (635 mm H <sub>2</sub> O)
Recommended air cleaner element - (standard)	Cummins Filtration AH1107
Recommended air cleaner element - (heavy duty)	Optional: primary element AF26124; secondary element AF26125

### Lubrication system

Oil pressure range at rated	40-60 PSI (276-414 kPa)
Oil capacity of pan (high - low)	11.6-9.5 qt. (11-9 L)
Total system capacity	3.2 gal. (12 L)
Recommended lube oil filter	Cummins Filtration LF3970

### Cooling system\*

Raw water working pressure range at heat exchanger	60 PSI (413 kPa) MAX
Recommended minimum water supply pipe size to heat exchanger	.75 in. (19.05 mm)
Recommended minimum water discharge pipe size from heat exchanger	1.00 in. (25.40 mm)
Coolant water capacity (engine only)	13 qt. (12.3 L)
Standard thermostat - type	Modulating
Standard thermostat - range	180-199 °F (82-93 °C)
Normal Operating Temperature	180-212 °F (82-100 °C)
Minimum raw water flow:	
- with water temperatures to 60 °F (16 °C)	9 GPM (0.57 L/sec)
- with water temperatures to 80 °F (27 °C)	10.5 GPM (0.66 L/sec)
- with water temperatures to 100 °F (38 °C)	12 GPM (0.76 L/sec)

\* A jacket water heater is mandatory on this engine. The recommended heater wattage is 1500 down to 40 °F (4 °C)

CFP5E Cooling Loop

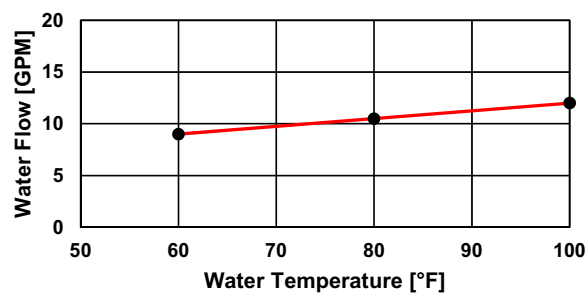



## Exhaust system

Maximum allowable back pressure by complete exhaust system	40.8 in. H <sub>2</sub> O (10.2 kPa)
Exhaust pipe size normally acceptable	4 in. (102 mm)

**Noise emissions** - The noise emission values are estimated sound pressure levels at 3.3 ft. (1 m).

Top	90.2 dBa
Right side	92.1 dBa
Left side	93.7 dBa
Front	93.0 dBa
Exhaust	112.1 dBa

## Fuel supply/drain system

Operating Speed in RPM	1470		1760		1900		2100		2350		2600	
<b>CFP5E/EVS F-10</b> Fuel Rate - Gal/hr (L/hr)	4.2	(15.9)	4.9	(18.5)	5.1	(19.3)	5.4	(20.4)	5.8	(21.9)	5.9	(22.2)
<b>CFP5E/EVS F-20</b> Fuel Rate - Gal/hr (L/hr)	4.7	(17.8)	5.5	(20.9)	5.7	(21.6)	6.0	(24.7)	6.5	(24.7)	6.6	(25.0)
<b>CFP5E/EVS F-30</b> Fuel Rate - Gal/hr (L/hr)	5.2	(19.7)	6.1	(23.0)	6.3	(23.8)	6.7	(25.2)	7.2	(27.2)	7.3	(27.5)
<b>CFP5E/EVS F-40</b> Fuel Rate - Gal/hr (L/hr)	5.7	(21.4)	6.3	(24.0)	6.7	(25.4)	7.2	(27.4)	7.9	(29.9)	7.9	(30.1)
<b>CFP5E/EVS F-50</b> Fuel Rate - Gal/hr (L/hr)	5.7	(21.4)	6.6	(25.2)	7.0	(26.6)	7.8	(29.4)	8.3	(31.3)	8.3	(31.6)

## Starting and electrical system

Fuel type	No. 2 diesel only	
Minimum supply line size	0.5 in. (12.70 mm)	
Minimum drain line size	0.375 in. (9.53 mm)	
Maximum fuel height above C/L fuel pump	360 in. (9.1 m)	
Recommended fuel filter - primary	Cummins Filtration FF5612 (Cummins 4989106)	
Recommended fuel filter - secondary	Cummins Filtration FS1212 (Cummins 3308638)	
Maximum restriction @ lift pump-inlet - with clean filter	5.0 in. Hg (127 mm Hg)	
Maximum restriction @ lift pump-inlet - with dirty filter	10.0 in. Hg (254 mm Hg)	
Maximum return line restriction - without check valves	5.9 in. Hg (150 mm Hg)	
Minimum fuel tank vent capability	7.1 ft <sup>3</sup> /hr (0.21 m <sup>3</sup> /hr)	
Maximum fuel temperature @ lift pump inlet	160 °F (71 °C)	

Minimum recommended battery capacity - cold soak at 0 °F (-18 °C) or above	12V	24V
Engine only - cold cranking amperes	1300 CCA*	900 CCA*
Engine only - reserve capacity	430 minutes*	430 minutes*
*Based on FM requirement for a minimum of 900 CCA and 430 reserve capacity minutes		
Battery cable size - minimum of 2/0 AWG and maximum cable length not to exceed 6 ft. (1.5 m)	12V	24V
Maximum resistance of starting circuit	0.001 Ohms	0.001 Ohms
Typical cranking speed	130 RPM	130 RPM
Alternator (standard), internally regulated	95 amps	45 amps

**Operating conditions**

Operating speed in RPM	1470		1760		1900		2100		2350		2600	
<b>CFP5E/EVS F-10</b>												
Output - BHP (kW)	84	(63)	95	(71)	98	(73)	101	(75)	105	(78)	104	(78)
Ventilation air required - CFM (litre/sec)	208	(98)	295	(139)	325	(153)	363	(171)	402	(190)	442	(209)
Exhaust gas flow - CFM (litre/sec)	520	(245)	670	(316)	711	(336)	774	(365)	862	(407)	905	(427)
Exhaust gas temperature - °F (°C)	869	(465)	869	(465)	869	(465)	869	(465)	869	(465)	869	(465)
Heat rejection to coolant - BTU/min. (kW)	1833	(32)	2100	(37)	2167	(38)	2367	(42)	2656	(47)	2789	(49)
Heat rejection to ambient - BTU/min. (kW)	825	(14)	868	(15)	930	(16)	993	(17)	973	(17)	954	(17)
<b>CFP5E/EVS F-20</b>												
Output - BHP (kW)	94	(70)	107	(80)	110	(82)	113	(84)	118	(88)	117	(87)
Ventilation air required - CFM (litre/sec)	222	(105)	305	(144)	336	(159)	369	(174)	403	(190)	443	(209)
Exhaust gas flow - CFM (litre/sec)	561	(265)	689	(325)	754	(356)	822	(388)	907	(428)	952	(450)
Exhaust gas temperature - °F (°C)	894	(479)	894	(479)	894	(479)	894	(479)	894	(479)	894	(479)
Heat rejection to coolant - BTU/min. (kW)	2009	(35)	2193	(39)	2364	(42)	2580	(45)	2889	(51)	3033	(53)
Heat rejection to ambient - BTU/min. (kW)	851	(15)	894	(16)	959	(17)	1024	(18)	1004	(18)	983	(17)
<b>CFP5E/EVS F-30</b>												
Output - BHP (kW)	104	(78)	118	(88)	121	(90)	125	(93)	130	(97)	129	(96)
Ventilation air required - CFM (litre/sec)	230	(109)	306	(144)	336	(159)	369	(174)	403	(190)	443	(209)
Exhaust gas flow - CFM (litre/sec)	587	(277)	700	(330)	763	(360)	836	(395)	927	(438)	973	(459)
Exhaust gas temperature - °F (°C)	927	(497)	927	(497)	927	(497)	927	(497)	927	(497)	927	(497)
Heat rejection to coolant - BTU/min. (kW)	2138	(38)	2291	(40)	2456	(43)	2680	(47)	3033	(53)	3185	(56)
Heat rejection to ambient - BTU/min. (kW)	876.9	(15)	922.1	(16)	988.9	(17)	1056	(19)	1035	(18)	1014	(18)
<b>CFP5E/EVS F-40</b>												
Output - BHP (kW)	113	(84)	123	(92)	129	(96)	136	(101)	143	(107)	141	(105)
Ventilation air required - CFM (litre/sec)	235	(111)	308	(145)	336	(159)	368	(174)	402	(190)	442	(209)
Exhaust gas flow - CFM (litre/sec)	607	(287)	706	(333)	766	(362)	840	(396)	930	(439)	977	(461)
Exhaust gas temperature - °F (°C)	933	(501)	933	(501)	933	(501)	933	(501)	933	(501)	933	(501)
Heat rejection to coolant - BTU/min. (kW)	2247	(39)	2343	(41)	2507	(44)	2775	(49)	3129	(55)	3285	(58)
Heat rejection to ambient - BTU/min. (kW)	904	(16)	950.6	(17)	1019	(18)	1088	(19)	1174	(21)	1226	(22)
<b>CFP5E/EVS F-50</b>												
Output - BHP (kW)	113	(84)	129	(96)	135	(101)	146	(109)	150	(112)	148	(110)
Ventilation air required - CFM (litre/sec)	235	(111)	312	(147)	335	(158)	366	(173)	401	(189)	441	(208)
Exhaust gas flow - CFM (litre/sec)	607	(287)	718	(339)	775	(366)	843	(398)	932	(440)	979	(462)
Exhaust gas temperature - °F (°C)	940	(504)	940	(504)	940	(504)	940	(504)	940	(504)	940	(504)
Heat rejection to coolant - BTU/min. (kW)	2247	(39)	2410	(42)	2603	(46)	2867	(50)	3171	(56)	3330	(59)
Heat rejection to ambient - BTU/min. (kW)	904	(16)	980	(17)	1051	(18)	1122	(20)	1211	(21)	1264	(22)

## 7.5 Cap screw markings and torque values



**Always use a cap screw of the same measurement and strength as the cap screw being replaced. Using the wrong cap screws can result in engine damage.**

Always use the torque values listed in the following tables when specific torque values are not available.



When the ft-lb value is less than 10, convert the ft-lb value to in-lb to obtain a better torque with an in-lb torque wrench. Example: 6 ft-lb equals 72 in-lb.

### 7.5.1 Cap screw identification

#### 7.5.1.1 Metric cap screw identification and head markings

<b>Sample:</b>	M8-1.25 x 25		
<b>Value:</b>	M8	1.25	X 25
<b>Meaning:</b>	Major thread diameter in millimeters	Distance between threads in millimeters	Length in millimeters

Metric cap screws and nuts are identified by the grade number stamped on the head of the cap screw or on the surface of the nuts.

<b>Commercial Steel Class</b>	8.8	10.9	12.9
<b>Caps Screw Head Markings</b>			

#### 7.5.1.2 US customary cap screw identification and head markings

<b>Sample:</b>	5/16 x 18 x 1-1/2		
<b>Value:</b>	5/16	18	1-1/2
<b>Meaning:</b>	Major thread diameter in inches	Number of threads per inch	Length in inches

U.S. Customary cap screws are identified by radial lines stamped on the head of the cap screw.

#### SAE grade 5 w/three lines



#### SAE grade 8

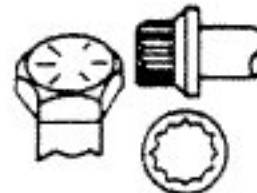

7.5.2 Cap screw torque values

**Table 7-1. Metric Cap Screw Torque Values (lubricated threads)**

Class:	8.8				10.9				12.9			
Diameter	Cast Iron		Aluminum		Cast Iron		Aluminum		Cast Iron		Aluminum	
mm	N•m	ft-lb	N•m	ft-lb	N•m	ft-lb	N•m	ft-lb	N•m	ft-lb	N•m	ft-lb
6	9	5	7	4	13	10	7	4	14	9	7	4
7	14	9	11	7	18	14	11	7	23	18	11	7
8	23	17	18	14	33	25	18	14	40	29	18	14
10	45	33	30	25	65	50	30	25	70	50	30	25
12	80	60	55	40	115	85	55	40	125	95	55	40
14	125	90	90	65	180	133	90	65	195	145	90	65
16	195	140	140	100	280	200	140	100	290	210	140	100
18	280	200	180	135	390	285	180	135	400	290	180	135
20	400	290	—	—	550	400	—	—	—	—	—	—

**Table 7-2. U.S. Customary Cap Screw Torque Values (lubricated threads)**

Grade:	SAE Grade 5				SAE Grade 8			
Cap Screw Body Size	Cast Iron		Aluminum		Cast Iron		Aluminum	
	N•m	ft-lb	N•m	ft-lb	N•m	ft-lb	N•m	ft-lb
1/4-20	9	7	8	6	15	11	8	6
1/4-28	12	9	9	7	18	13	9	7
5/16-18	20	15	16	12	30	22	16	12
5/16-24	23	17	19	14	33	24	19	14
3/8-16	40	30	25	20	55	40	25	20
3/8-24	40	30	35	25	60	45	35	25
7/16-14	60	45	45	35	90	65	45	35
7/16-20	65	50	55	40	95	70	55	40
1/2-13	95	70	75	55	130	95	75	55
1/2-20	100	75	80	60	150	110	80	60
9/16-12	135	100	110	80	190	140	110	80
9/16-18	150	110	115	85	210	155	115	85
5/8-11	180	135	150	110	255	190	150	110
5/8-18	210	155	160	120	290	215	160	120
3/4-10	325	240	255	190	460	340	255	190
3/4-16	365	270	285	210	515	380	285	210
7/8-9	490	360	380	280	745	550	380	280
7/8-14	530	390	420	310	825	610	420	310
1-8	720	530	570	420	1100	820	570	420
1-14	800	590	650	480	1200	890	650	480

## 7.6 CFP5E/EVS assembly drawings

Please refer to our website at [cummins.com](http://cummins.com) for the most up-to-date information.

Drawing No.	Description
A042J654	General Arrangement, Installation, Fire Pump, CFP5E/EVS
A042H676	Assembly, Fire Pump, CFP5E/EVS F10-F50
13211	Assembly, Engine, CFP5E/EVS, 12V
13211-24	Assembly, Engine, CFP5E/EVS, 24V
13772	Valve Cover, CFP5E/EVS
13847	Assembly, Engine Mounting, CFP5E, Isolated
A042H704	Assembly, Heat Exchanger CFP5E/EVS, Raw Water
A042H722	Assembly, Heat Exchanger CFP5E/EVS, Sea Water
A042A396	Assembly, Air Intake CFP5E/EVS
A042J188	Assembly, Coolant Heater CFP5E/EVS
A042H709	Assembly, Fuel Pre-Filter CFP5E/EVS-CFP7E/EVS
14202	Option, Fuel Rail CFP5E/EVS
A042H288	Assembly, Sensors and Harnessing CFP5E/EVS
13309	Assembly, Secondary ECM CFP5E/EVS-CFP7E/EVS
21249	Assembly, Control Panel Mounting
<b>Assembly, All Components Top-level:</b>	
A042G185	Assembly, Panel, Digital Electronic
8824-12	Battery Contactors 12V
8824-24	Battery Contactors 24V
A042H710	Kit, Fuel Lines CFP5E/EVS
26132	Misc. Piping, Cooling Loop, Raw Water CFP5E
A042H724	Assembly, Raw Water Cooling Loop, 3/4" Vertical
A042H725	Assembly, Raw Water Cooling Loop, 3/4" Horizontal 12V
A042H726	Assembly, Raw Water Cooling Loop, 3/4" Horizontal 24V
A042B480	Misc. Piping, Cooling Loop, Sea Water CFP5E/EVS-CFP7E/EVS
A042H727	Assembly, Sea Water Cooling Loop, 3/4" Vertical
A042H728	Assembly, Sea Water Cooling Loop, 3/4" Horizontal 12V
A042H729	Assembly, Sea Water Cooling Loop, 3/4" Horizontal 24V
8619	Assembly, Stub-Shaft and Guarding
A042J121	Schematic, Overall CFP5E/EVS, GEN II FPDP
A042E428	Assembly, VSPLC (FM-approved option)

This page is intentionally left blank.

LEGEND AND DATUM IDENTIFIER	
SHEET 1	INSTALLATION DRAWING
SHEET 2	GENERAL ARRANGEMENT - HORIZONTAL SPLIT CASE PUMP BASE OPTION
SHEET 3	GENERAL ARRANGEMENT - VERTICAL TURBINE PUMP BASE OPTION
SHEET 4	DRIVE LINE OPTIONS
SHEET 5	ELECTRICAL INFORMATION
DATUM "A"	FACE OF FLYWHEEL HOUSING
DATUM "B"	REAR LEG BOLT LOCATION
DATUM "C"	FLYWHEEL MOUNTING SURFACE
DATUM "D"	UJOINT ADAPTER MOUNTING SURFACE
DATUM "EOS"	END OF PUMP SHAFT

CFP5E CONNECTION INFORMATION	
SAE #3	FLYWHEEL HOUSING
1/2" NPT	FUEL INLET
3/8" NPT	FUEL OUTLET
3/4" NPT	RAW WATER INLET
1" NPT	RAW WATER DISCHARGE
120 / 240 VAC	COOLANT HEATER (1500WATTS)
3" DIA NPT, CUFF, OR FLANGE	EXHAUST CONNECTION
1/2" NPT	VSPLC CONNECTION

REV	REL NO	REVISION	DWN	CKD	APVD	DATE
0	2016-668	INITIAL RELEASE	HE392	-	-	05JAN17
1	2020-021	ADDED CG DIMENSIONS & NOTES	NO134	MS707	MS707	29JAN20

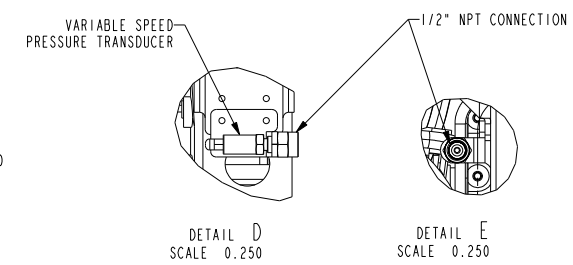
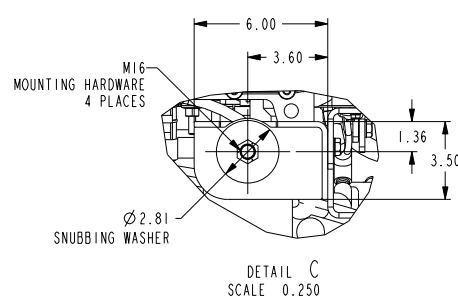
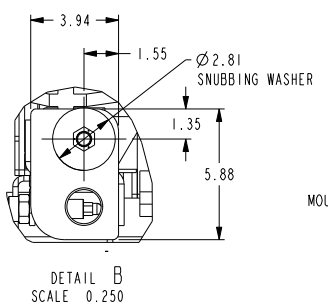
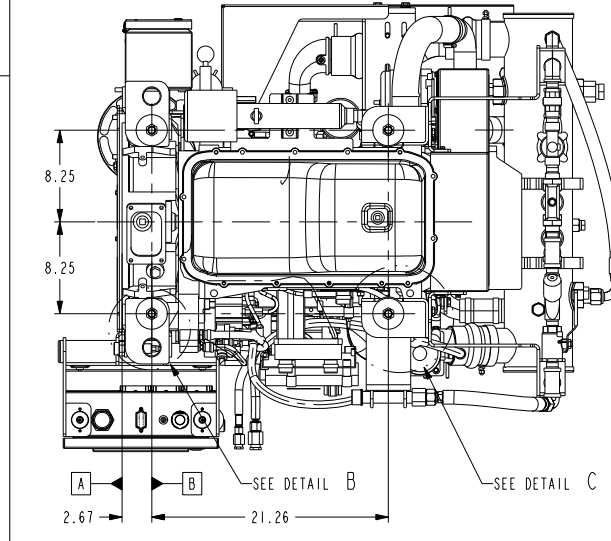
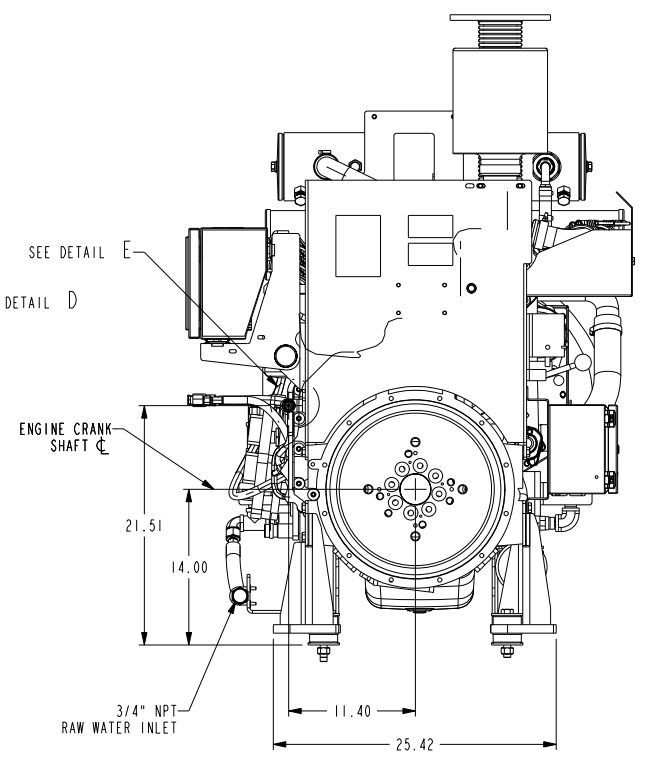
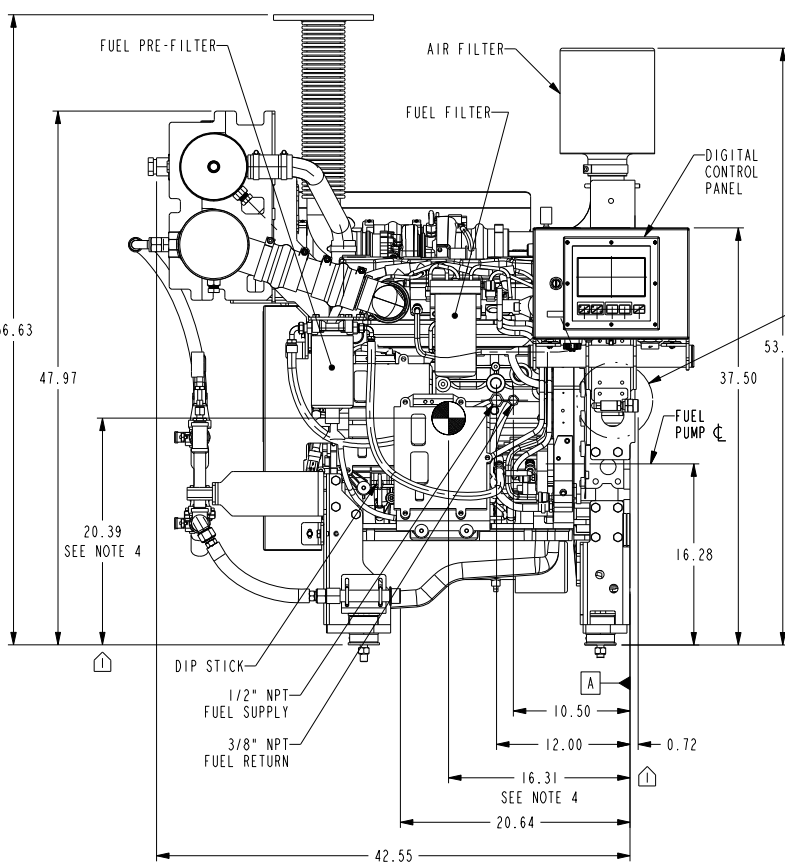
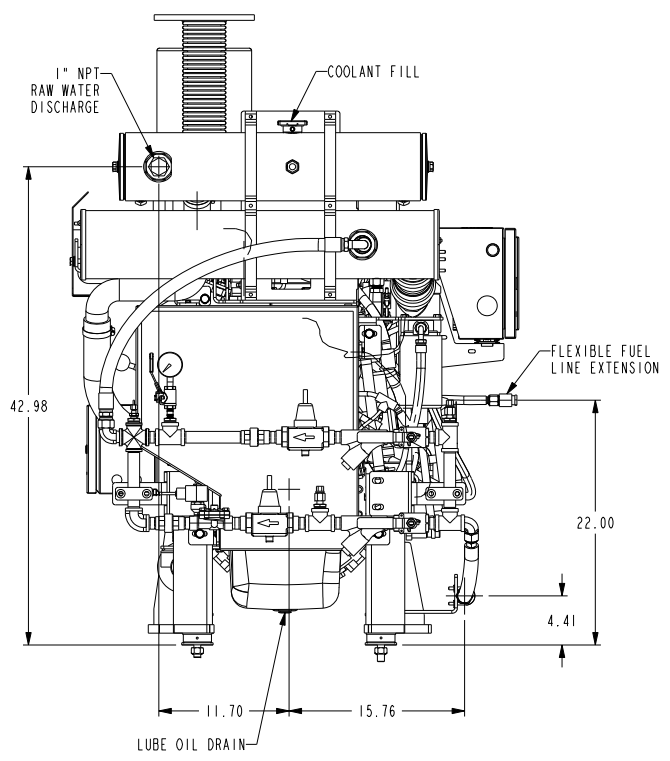
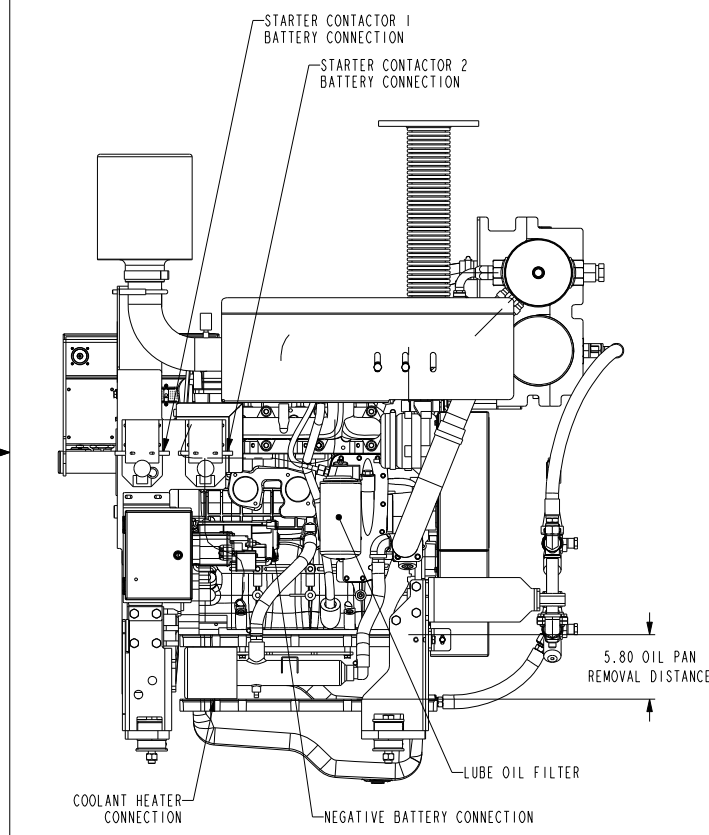

- NOTES:
- ALL PLUMBING MUST BE SUPPORTED AND/OR ISOLATED SO THAT NO WEIGHT OR STRESS IS APPLIED TO ANY ENGINE COMPONENT
  - REFER TO ENGINE DATA SHEET FOR CUSTOMER CONNECTION RECOMMENDATIONS
  - DRAWING SUBJECT TO CHANGE WITH OUT NOTICE
  - CENTER OF GRAVITY LOCATION IS APPROXIMATE

DIMENSIONS ARE IN: INCHES 1. ARE IN: DRAWING TOLERANCES APPLY TO PRIMARY DIMENSIONS UNLESS OTHERWISE SPECIFIED	DO NOT SCALE PRINT SCALE 0.125	CMV DATA CLASSIFICATION Cummins Confidential	Cummins Inc.
X: ± 0.10 IN OR 0.75 mm Y: ± 0.10 IN OR 0.75 mm Z: ± 0.10 IN OR 0.75 mm ANGULAR TOLERANCE: ± 0.5°	SCALE 0.125	DWN: HE392 CKD: - APVD: - DATE: 05JAN2017	ITEM NAME GENERAL ARRANGEMENT CFP5E-F10/20/30/40/50
THIS DOCUMENT (AND THE INFORMATION SHOWN THEREIN) IS CONFIDENTIAL AND PROPRIETARY AND SHALL NOT BE DISCLOSED TO OTHERS IN HARD COPY OR ELECTRONIC FORM, REPRODUCED BY ANY MEANS, OR USED FOR ANY PURPOSE WITHOUT WRITTEN CONSENT OF CUMMINS INC.	FOR INTERPRETATION OF DIMENSIONING AND TOLERANCING, SEE ASME Y14.5-2009	MUST CONFORM TO CES 10903	CAD SHEET 1 OF 5 ITEM NUMBER A042J654

LEGEND AND DATUM IDENTIFIER	
SHEET 1	INSTALLATION DRAWING
SHEET 2	GENERAL ARRANGEMENT - HORIZONTAL SPLIT CASE PUMP BASE OPTION
SHEET 3	GENERAL ARRANGEMENT - VERTICAL TURBINE PUMP BASE OPTION
SHEET 4	DRIVE LINE OPTIONS
SHEET 5	ELECTRICAL INFORMATION
DATUM "A"	FACE OF FLYWHEEL HOUSING
DATUM "B"	REAR LEG BOLT LOCATION
DATUM "C"	FLYWHEEL MOUNTING SURFACE
DATUM "D"	UJOINT ADAPTER MOUNTING SURFACE
DATUM "EOS"	END OF PUMP SHAFT

REV	REL NO	REVISION	DWN	CKD	APVD	DATE
0	2016-668	INITIAL RELEASE	HE392	-	-	05JAN17
1	2020-021	SEE SHEET 1 FOR REVISION DETAILS	NO134	MS707	MS707	29JAN20

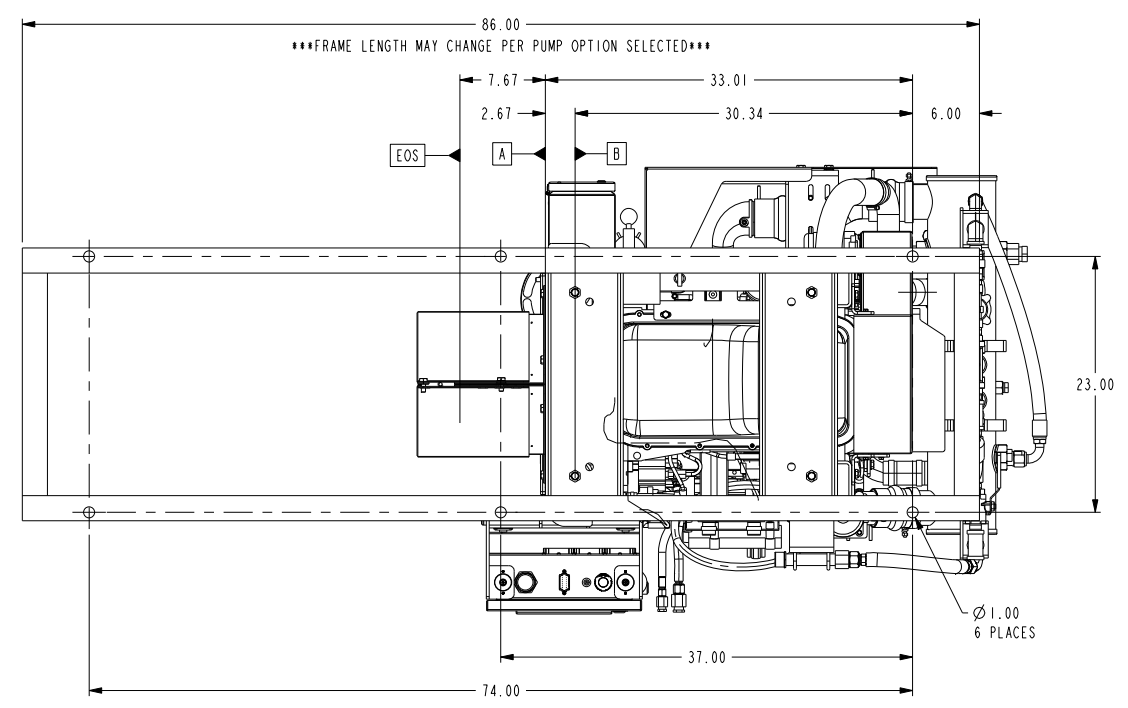
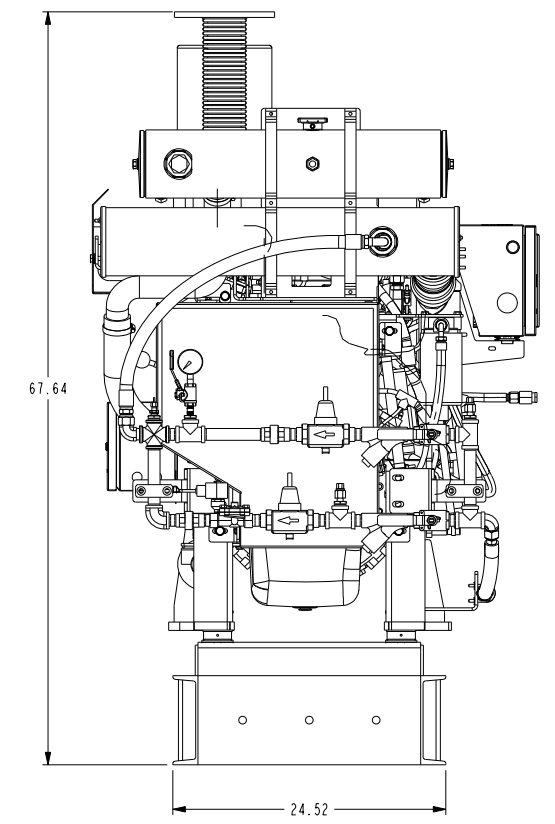
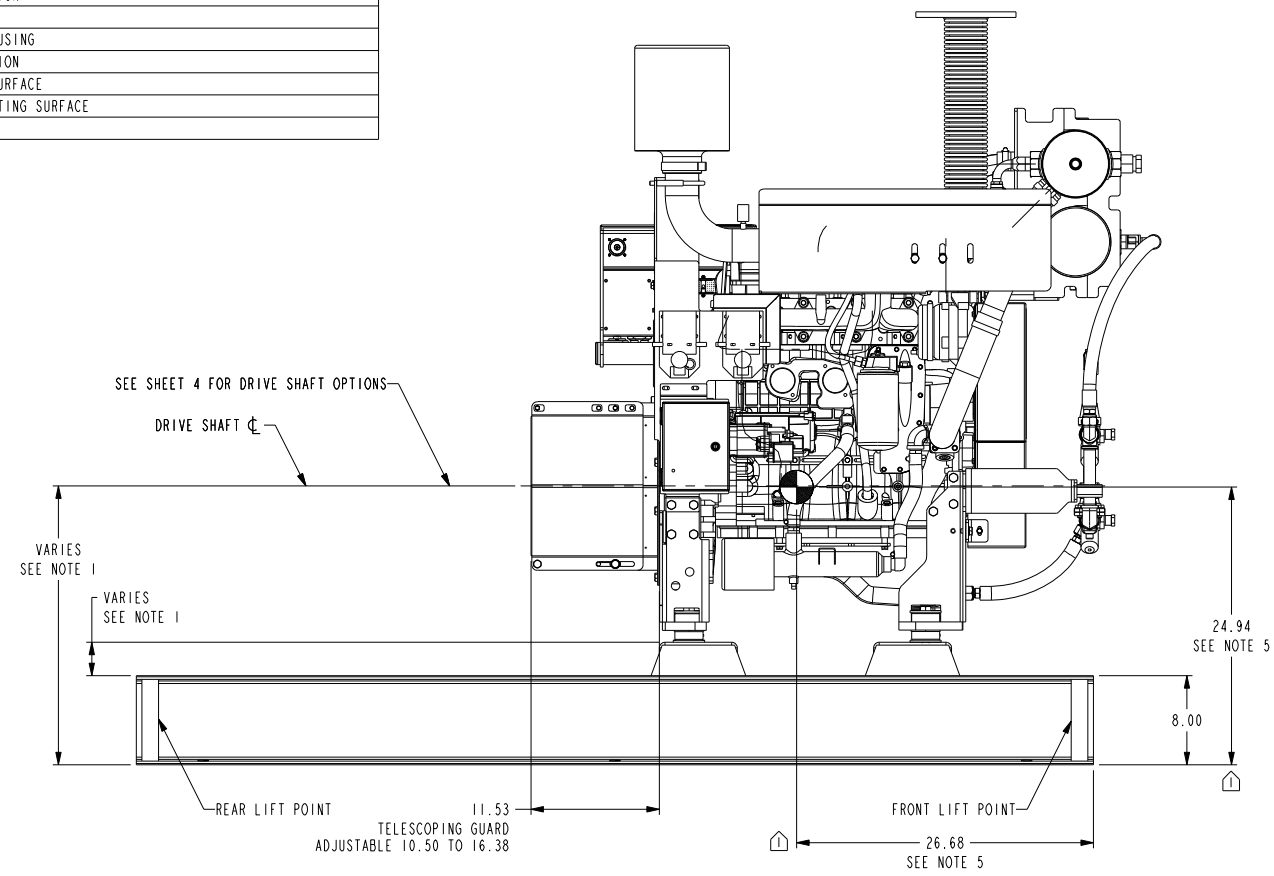

- NOTES:
1. RISER HEIGHT VARIES TO ACCOMMODATE CUSTOMER SUPPLIED PUMPS
  2. REFERENCE OWNERS MANUAL FOR DRIVE SHAFT ALIGNMENT SPECS
  3. DRAWING SUBJECT TO CHANGE WITH OUT NOTICE
  4. REFERENCE SHEET 1 FOR BASE FIRE PUMP INTERFACE
  5. CENTER OF GRAVITY LOCATION IS APPROXIMATE & DOES NOT INCLUDE U-JOINT ADAPTER, DRIVE SHAFT, COMPANION FLANGE OR DRIVE SHAFT GUARDS

DIMENSIONS ARE IN: INCHES 1.1 ARE IN: DRAWING TOLERANCES APPLY TO PRIMARY DIMENSIONS UNLESS OTHERWISE SPECIFIED	DO NOT SCALE PRINT SCALE 0.125	CMI DATA CLASSIFICATION Cummins Confidential	Cummins Inc.
F: ± 0.10 IN OR 4 mm M: ± 0.05 IN OR 2 mm H: ± 0.03 IN OR 0.75 mm A: ± 0.02 IN OR 0.5 mm ANGULAR TOLERANCE: ±		DWN: HE392 CKD: - APVD: - DATE: 05JAN2017	ITEM NAME GENERAL ARRANGEMENT CFP5E-F10/20/30/40/50
THIS DOCUMENT (AND THE INFORMATION SHOWN THEREIN) IS CONFIDENTIAL AND PROPRIETARY AND SHALL NOT BE DISCLOSED TO OTHERS IN HARD COPY OR ELECTRONIC FORM, REPRODUCED BY ANY MEANS, OR USED FOR ANY PURPOSE WITHOUT WRITTEN CONSENT OF CUMMINS INC.	FOR INTERPRETATION OF DIMENSIONING AND TOLERANCING, SEE ASME Y14.5-2009	MUST CONFORM TO CES 10903	CAD SHEET 2 OF 5 ITEM NUMBER A042J654 REV 1



LEGEND AND DATUM IDENTIFIER	
SHEET 1	INSTALLATION DRAWING
SHEET 2	GENERAL ARRANGEMENT - HORIZONTAL SPLIT CASE PUMP BASE OPTION
SHEET 3	GENERAL ARRANGEMENT - VERTICAL TURBINE PUMP BASE OPTION
SHEET 4	DRIVE LINE OPTIONS
SHEET 5	ELECTRICAL INFORMATION
DATUM "A"	FACE OF FLYWHEEL HOUSING
DATUM "B"	REAR LEG BOLT LOCATION
DATUM "C"	FLYWHEEL MOUNTING SURFACE
DATUM "D"	UJOINT ADAPTER MOUNTING SURFACE
DATUM "EOS"	END OF PUMP SHAFT

REV	REL NO	REVISION	DWN	CKD	APVD	DATE
0	2016-668	INITIAL RELEASE	HE392	-	-	05JAN17
1	2020-021	SEE SHEET 1 FOR REVISION DETAILS	NO134	MS707	MS707	29JAN20

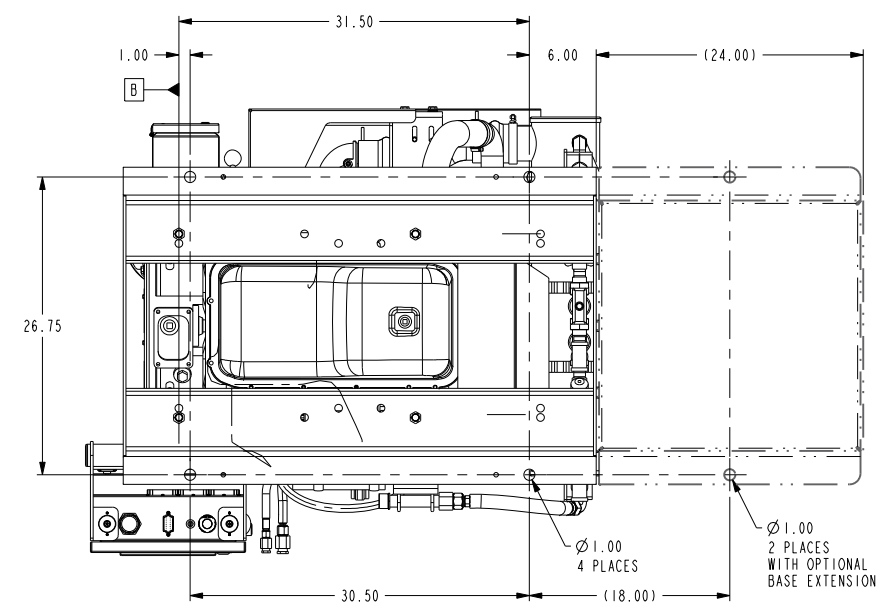
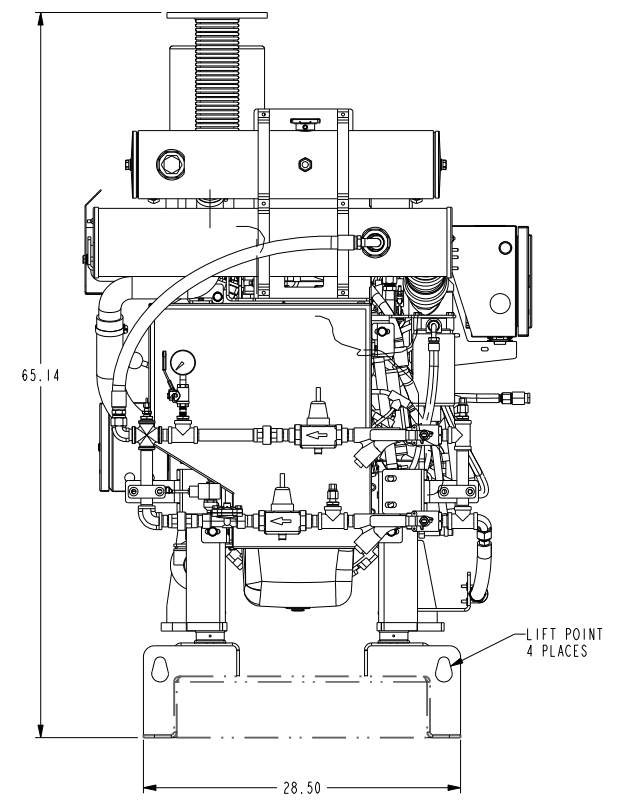
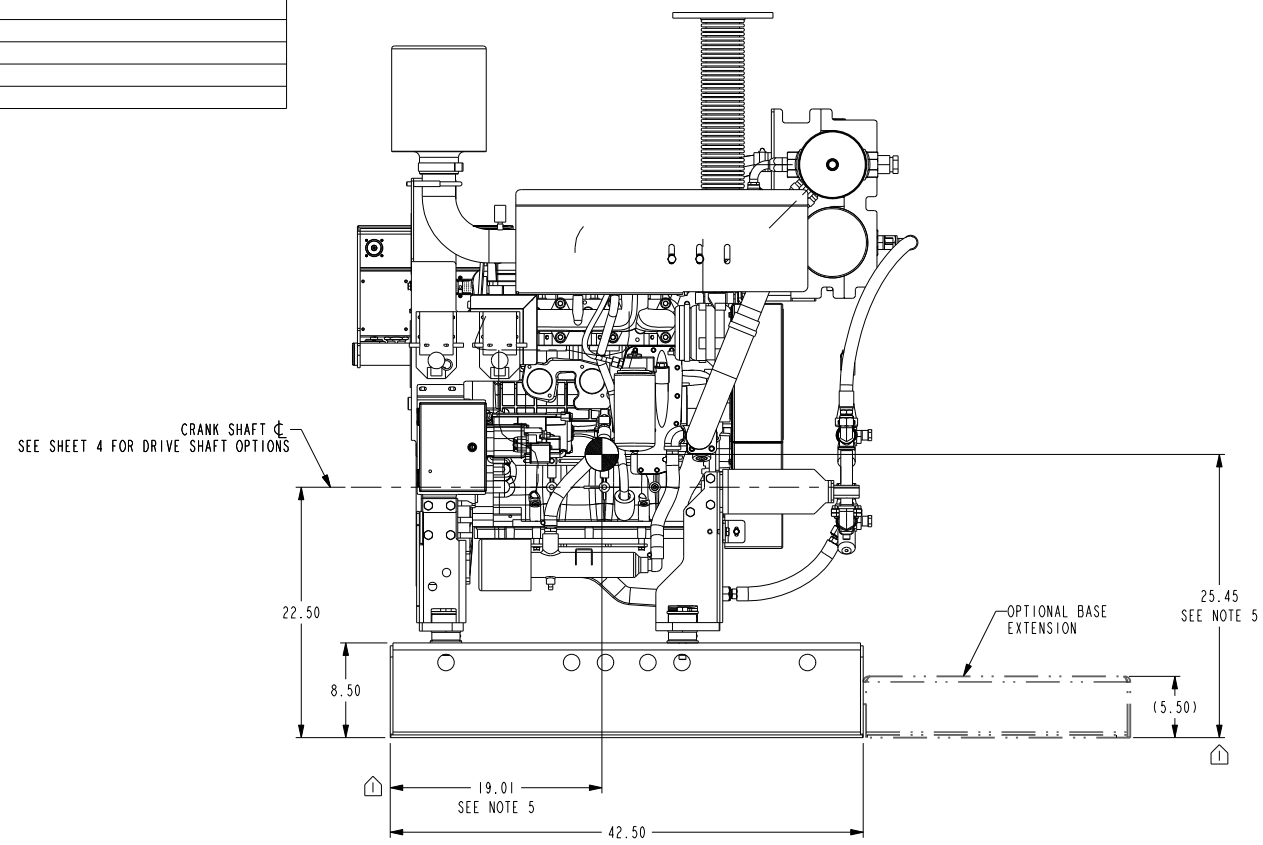

- NOTES:
- TORSIONAL ANALYSIS IS REQUIRED FOR VERTICAL TURBINE INSTALLATION
  - REFERENCE OWNERS MANUAL FOR DRIVE SHAFT ALIGNMENT SPECS
  - DRAWING SUBJECT TO CHANGE WITH OUT NOTICE
  - REFERENCE SHEET 1 FOR BASE FIRE PUMP INTERFACE
  - CENTER OF GRAVITY LOCATION IS APPROXIMATE & DOES NOT INCLUDE BASE EXTENSION

DIMENSIONS ARE IN: INCHES 1.1 ARE IN:	<b>DO NOT SCALE PRINT</b>	CMI DATA CLASSIFICATION Cummins Confidential		Cummins Inc.	
DRAWING TOLERANCES APPLY TO PRIMARY DIMENSIONS UNLESS OTHERWISE SPECIFIED	SCALE 0.125	DWN: HE392		ITEM NAME GENERAL ARRANGEMENT	
F: ± 0.10 IN OR 3 mm M: ± 0.05 IN OR 1.27 mm H: ± 0.03 IN OR 0.76 mm V: ± 0.02 IN OR 0.51 mm ANGULAR TOLERANCE: ±		CKD: -	CAD SHEET 3 OF 5		
THIS DOCUMENT (AND THE INFORMATION SHOWN THEREIN) IS CONFIDENTIAL AND PROPRIETARY AND SHALL NOT BE DISCLOSED TO OTHERS IN HARD COPY OR ELECTRONIC FORM, REPRODUCED BY ANY MEANS, OR USED FOR ANY PURPOSE WITHOUT WRITTEN CONSENT OF CUMMINS INC.	FOR INTERPRETATION OF DIMENSIONING AND TOLERANCING, SEE ASME Y14.5-2009	APVD: -	ITEM NUMBER A042J654		
		DATE: 05JAN2017	MUST CONFORM TO CES 10903	REV 1	

LEGEND AND DATUM IDENTIFIER	
SHEET 1	INSTALLATION DRAWING
SHEET 2	GENERAL ARRANGEMENT - HORIZONTAL SPLIT CASE PUMP BASE OPTION
SHEET 3	GENERAL ARRANGEMENT - VERTICAL TURBINE PUMP BASE OPTION
SHEET 4	DRIVE LINE OPTIONS
SHEET 5	ELECTRICAL INFORMATION
DATUM "A"	FACE OF FLYWHEEL HOUSING
DATUM "B"	REAR LEG BOLT LOCATION
DATUM "C"	FLYWHEEL MOUNTING SURFACE
DATUM "D"	UJOINT ADAPTER MOUNTING SURFACE
DATUM "EOS"	END OF PUMP SHAFT

ENGINE MODELS	CFP DRIVE SHAFT MATRIX					
	CFP F-RATING WITH MULTIPLE SHAFTS					
	RPM 1470	RPM 1760	RPM 1900	RPM 2100	RPM 2350	RPM 2600
CPF5E-F10	1610 SHAFT	1610 SHAFT	1610 SHAFT	1610 SHAFT	1610 SHAFT	1610 SHAFT
CPF5E-F20	1610 SHAFT	1610 SHAFT	1610 SHAFT	1610 SHAFT	1610 SHAFT	1610 SHAFT
CPF5E-F30	1610 SHAFT	1610 SHAFT	1610 SHAFT	1610 SHAFT	1610 SHAFT	1610 SHAFT
CPF5E-F40	1610 SHAFT	1610 SHAFT	1610 SHAFT	1610 SHAFT	1610 SHAFT	1610 SHAFT
CPF5E-F50	1610 SHAFT	1610 SHAFT	1610 SHAFT	1610 SHAFT	1610 SHAFT	1610 SHAFT

REV	REL NO	REVISION	DWN	CKD	APVD	DATE
0	2016-668	INITIAL RELEASE	HE392	-	-	05JAN17
1	2020-021	SEE SHEET 1 FOR REVISION DETAILS	NO134	MS707	MS707	29JAN20

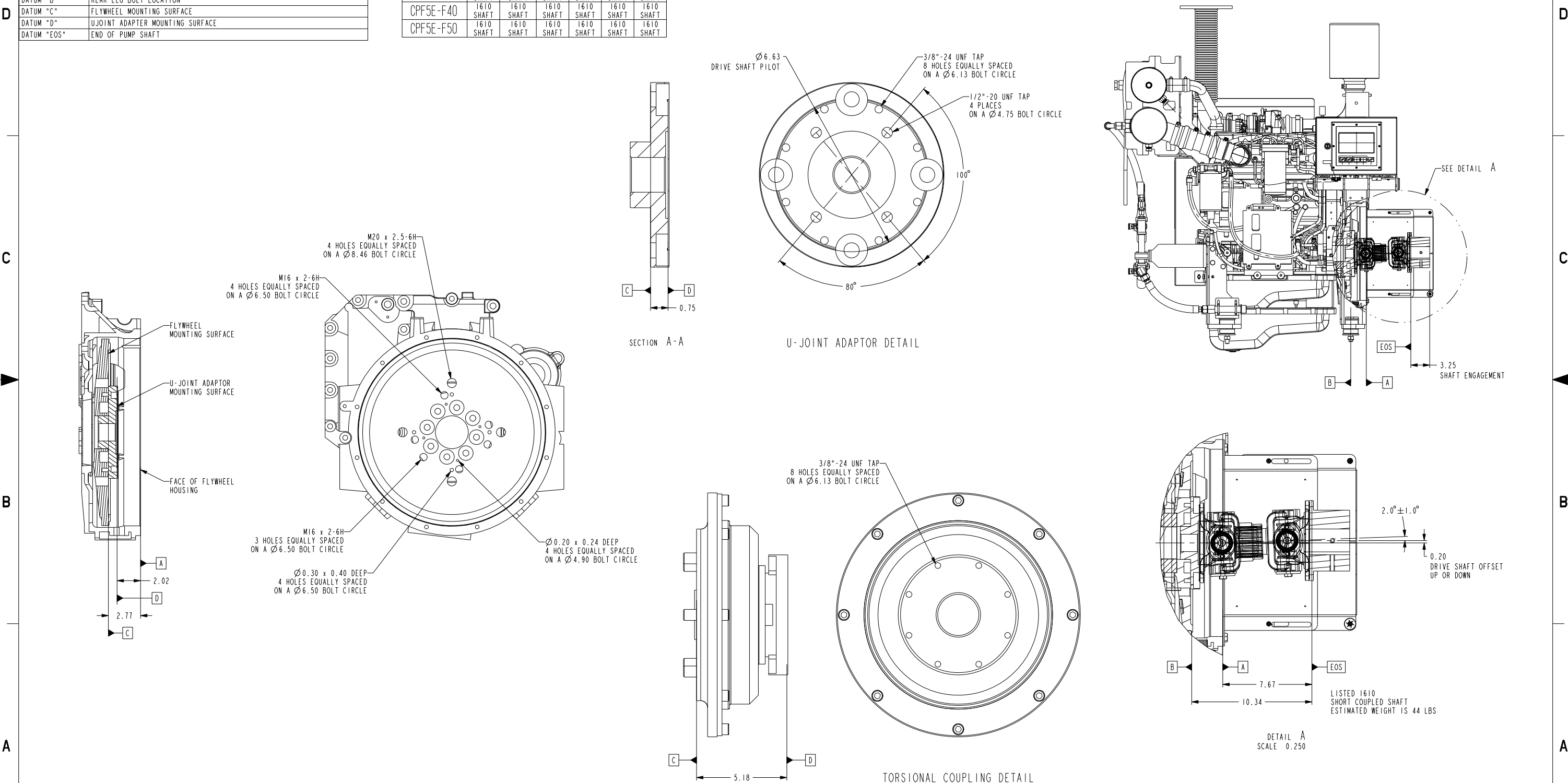

- NOTES:
- TORSIONAL ANALYSIS IS REQUIRED FOR VERTICAL TURBINE INSTALLATION
  - REFERENCE OWNERS MANUAL FOR DRIVE SHAFT ALIGNMENT SPECS
  - DRAWING SUBJECT TO CHANGE WITH OUT NOTICE
  - REFERENCE SHEET 1 FOR BASE FIRE PUMP INTERFACE

DIMENSIONS ARE IN: INCHES 1:1 ARE IN: DRAWING TOLERANCES APPLY TO PRIMARY DIMENSIONS UNLESS OTHERWISE SPECIFIED	DO NOT SCALE PRINT SCALE 0.125	CMI DATA CLASSIFICATION Cummins Confidential		Cummins Inc.	
F: ± 1/16 IN OR 0.6 mm M: ± 1/32 IN OR 0.1 mm H: ± 0.001 IN OR 0.025 mm L: ± 0.001 IN OR 0.025 mm ANGULAR TOLERANCE: ± 0.5°	DWN: HE392 CKD: APVD: DATE: 05JAN2017	ITEM NAME GENERAL ARRANGEMENT CPF5E-F10/20/30/40/50		CAD SHEET 4 OF 5	ITEM NUMBER A042J654

LEGEND AND DATUM IDENTIFIER	
SHEET 1	INSTALLATION DRAWING
SHEET 2	GENERAL ARRANGEMENT - HORIZONTAL SPLIT CASE PUMP BASE OPTION
SHEET 3	GENERAL ARRANGEMENT - VERTICAL TURBINE PUMP BASE OPTION
SHEET 4	DRIVE LINE OPTIONS
SHEET 5	ELECTRICAL INFORMATION
DATUM "A"	FACE OF FLYWHEEL HOUSING
DATUM "B"	REAR LEG BOLT LOCATION
DATUM "C"	FLYWHEEL MOUNTING SURFACE
DATUM "D"	UJOINT ADAPTER MOUNTING SURFACE
DATUM "EOS"	END OF PUMP SHAFT

REV	REL NO	REVISION	DWN	CKD	APVD	DATE
0	2016-668	INITIAL RELEASE	HE392	-	-	05JAN17
1	2020-021	SEE SHEET 1 FOR REVISION DETAILS	NO134	MS707	MS707	29JAN20

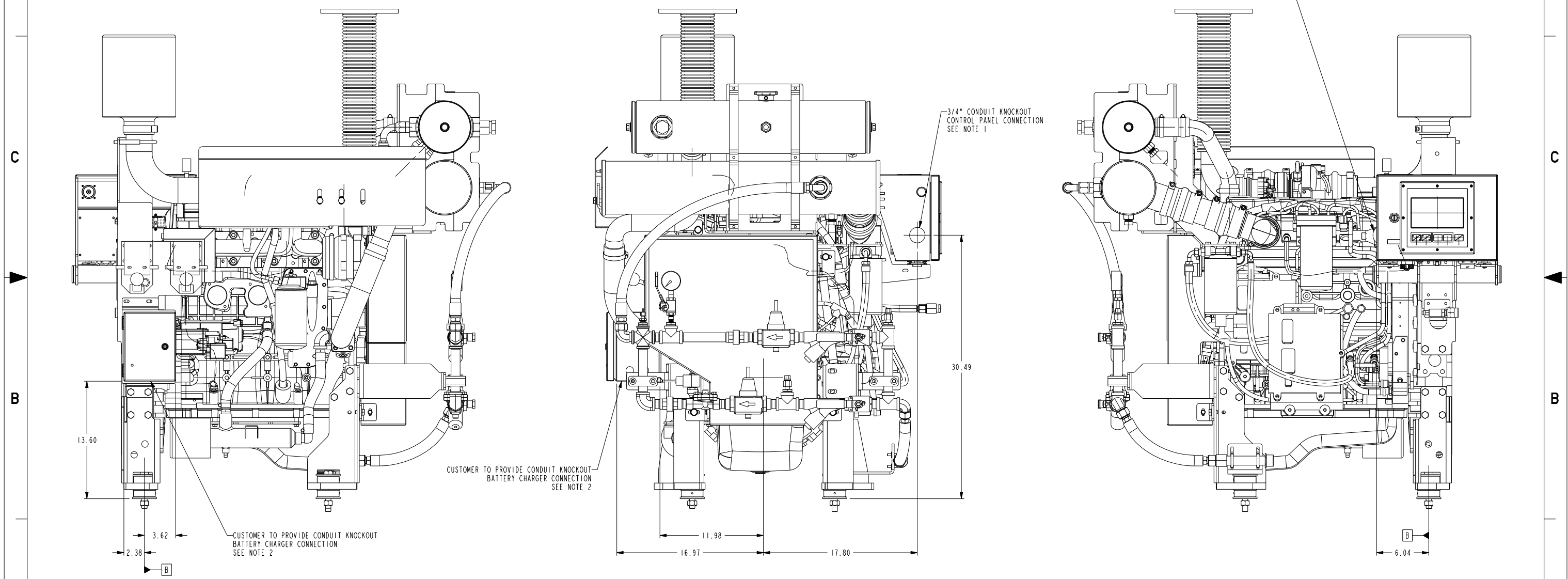



- NOTES:
- CONTROL PANEL TERMINAL BLOCKS  
1, 2, 3, 4, 5, 9, 10, 301, 302, 303, 304, 310, 311, 312
  - BATTERY CHARGER CONNECTION BOX TERMINAL BLOCKS  
6, 8, 11

DIMENSIONS ARE IN: INCHES 1.1 ARE IN: DRAWING TOLERANCES APPLY TO PRIMARY DIMENSIONS UNLESS OTHERWISE SPECIFIED	DO NOT SCALE PRINT SCALE 0.188	CMI DATA CLASSIFICATION Cummins Confidential		Cummins Inc.
<small>           F: ± 0.10 IN OR 2.54 mm            M: ± 0.005 IN OR 0.127 mm            H: ± 0.002 IN OR 0.051 mm            ANGULAR TOLERANCE: ± 0.5°         </small>	<small>           DWN: HE392            CKD: -            APVD: -            DATE: 05JAN2017         </small>	<small>           FOR INTERPRETATION OF DIMENSIONING AND TOLERANCING, SEE ASME Y14.5-2009         </small>		<small>           MUST CONFORM TO CES 10903         </small>
<small>           THIS DOCUMENT (AND THE INFORMATION SHOWN THEREON) IS CONFIDENTIAL AND PROPRIETARY AND SHALL NOT BE DISCLOSED TO OTHERS IN HARD COPY OR ELECTRONIC FORM, REPRODUCED BY ANY MEANS, OR USED FOR ANY PURPOSE WITHOUT WRITTEN CONSENT OF CUMMINS INC.         </small>			<small>           CAD SHEET            5 OF 5         </small>	<small>           ITEM NUMBER            A042J654         </small>

BILL OF MATERIAL			
ITEM	QTY	DESCRIPTION	PART NUMBER
1	1	EXHAUST, 90° HALF MARMON; 3" TURBO OUT	8550-04
2	2	CONTACTOR, MANUAL OVERRIDE, 12V; PN:535-0127, FIREPUMP	8824-12
3	1	ASSEMBLY, ECM & MOUNTING; CFP5E & CFP7E	13309
4	1	ASSEMBLY, ENGINE MOUNTING; ISOLATED, CFP5E	13847
5	1	ASSEMBLY, CONTROL PANEL MOUNTING; CFP POWER UNITS	21249
6	1	ASSEMBLY, MISC PIPING; CFP5E	26132
7	1	ASSEMBLY, AIR CLEANER; CFP5E	A042A396
8	1	ENCLOSURE, INTERFACE; BATTERY CHARGER FIRE PUMP	A042C868
9	1	ASSEMBLY, GUARDING; CFP5E	A042E666
10	1	ASSEMBLY, SENSORS & HARNESSING; CFP5E	A042H288
11	1	ASSEMBLY, HEAT EXCHANGERS; CFP5E	A042H704
12	1	ASSEMBLY, FUEL PREFILTER;	A042H709
13	1	ASSEMBLY, FUEL LINE; CFP5E	A042H710
14	1	COOLING LOOP, 3/4", 12V; RAW WATER	A042H725
15	1	CONTROL ASSEMBLY; FPDP ELECTRONIC CARBON STEEL	A042H780
16	1	ASSEMBLY, ACCESSORY MOUNTING; CFP5E	A042J151
17	1	ASSEMBLY, COOLANT HEATER; CFP5E	A042J188
18	1	ASSEMBLY, 12VDC ENGINE; CFP5E-F10/20/30/40/50	A042K056
19	1	PAINT, SPRAY BOMB; CUMMINS RED, ES044 RAL 3001	A15730-A12
20	1	PLUG, 1/2 NPT;	LTL-SCSP12

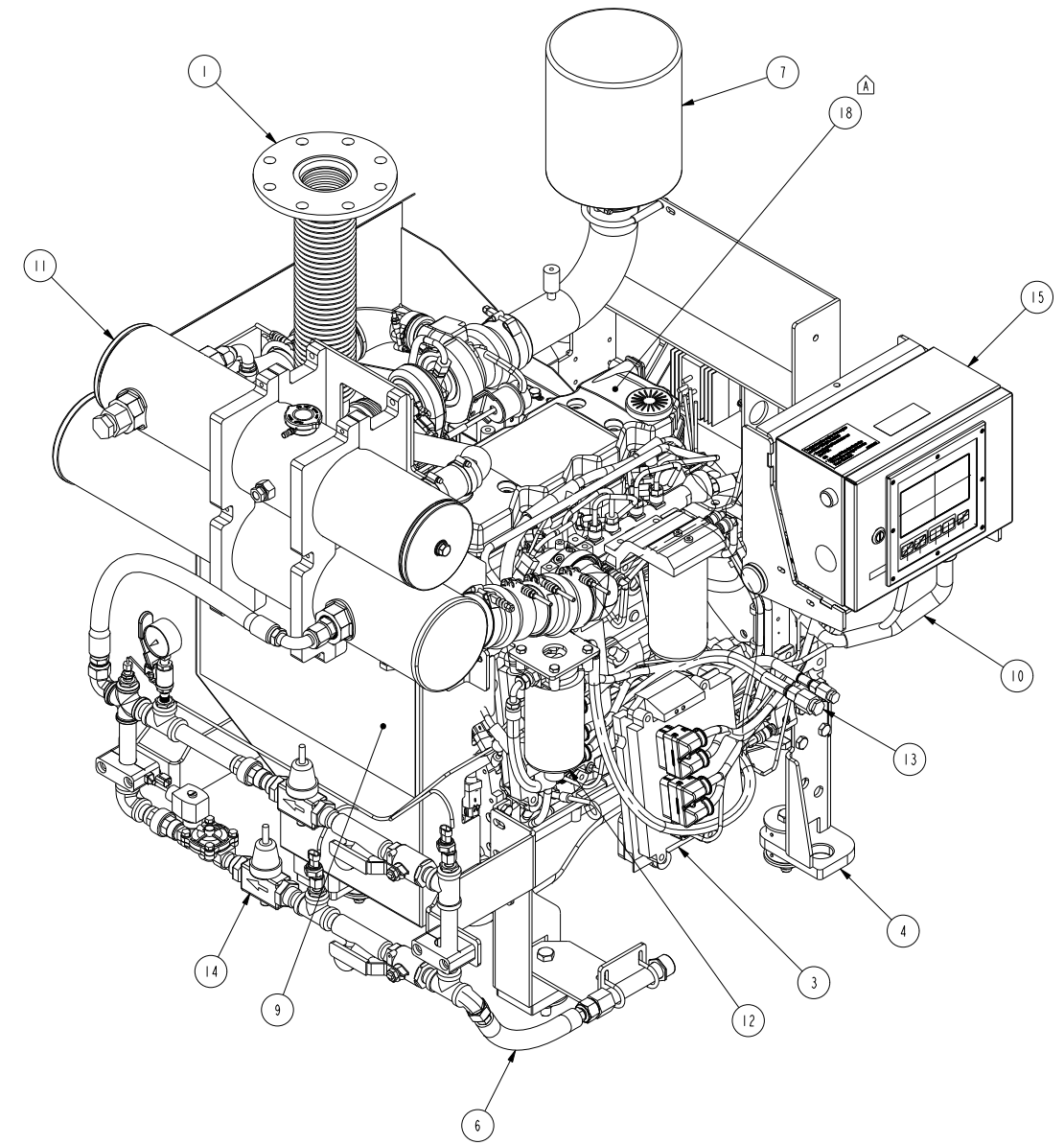
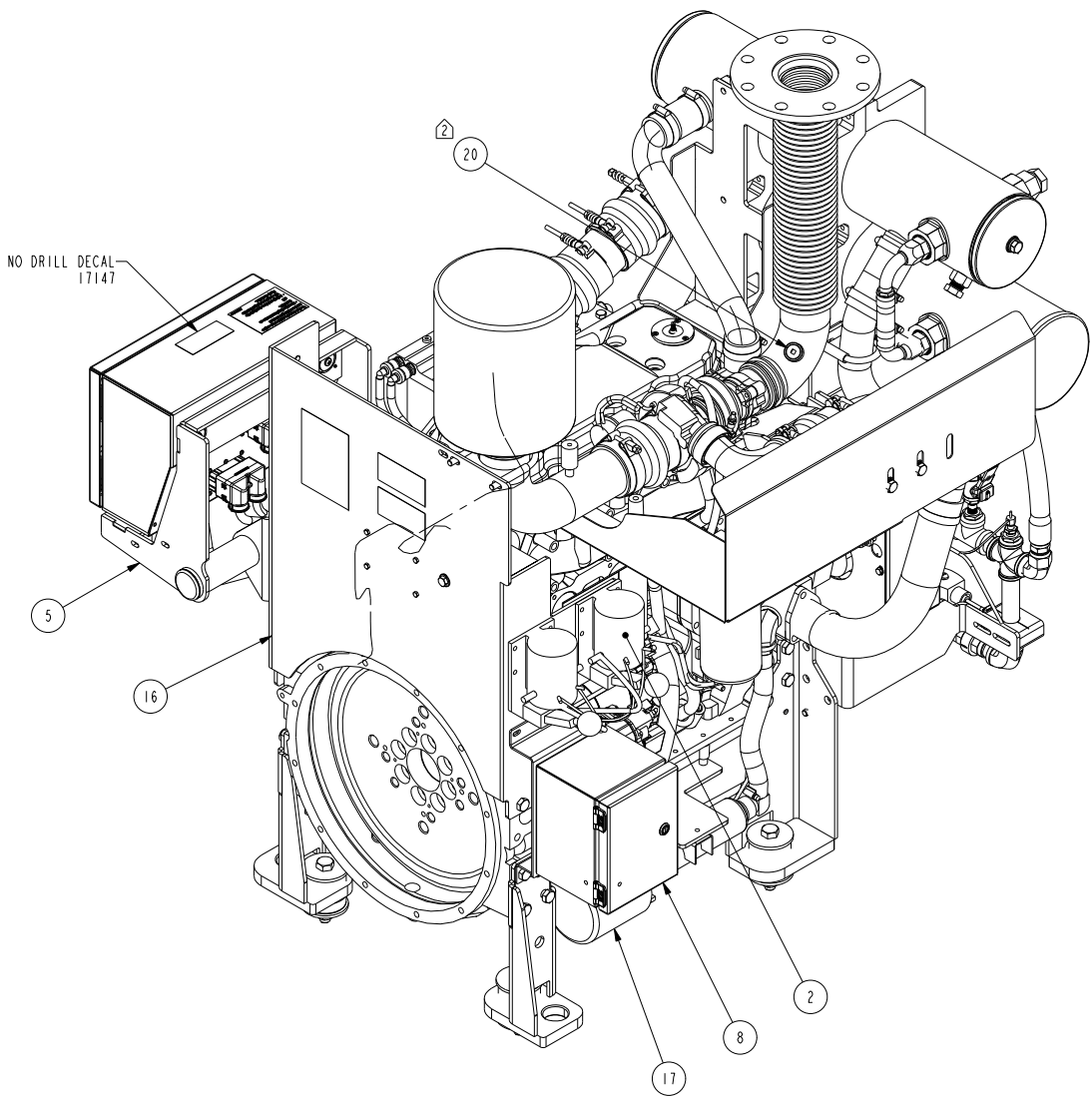
REV	REL NO	REVISION	DWN	CKD	APVD	DATE
A	2017-137	DELETE 26766; ADD A042K056	HE392	-	-	07MAR17
2	2019-580	REPLACED LTL-SCSP14 W/ LTL-SCSP12; ADDED DIMENSIONS & NOTE	NO134	MS707	MS707	03DEC19



DIMENSIONS ARE IN: INCHES 1.1 ARE IN:	DO NOT SCALE PRINT SCALE 0.188	CMI DATA CLASSIFICATION Cummins Confidential		Cummins Inc.	
DRAWING TOLERANCES APPLY TO PRIMARY DIMENSIONS UNLESS OTHERWISE SPECIFIED X: ± .10 IN OR 3 mm Y: ± .10 IN OR 3 mm Z: ± .030 IN OR 0.75 mm H: ± .010 IN OR 0.25 mm M: ± .010 IN OR 0.25 mm ANGULAR TOLERANCE: ±	SCALE 0.188	DWN: HE392 CKD: APVD: NE627 DATE: 16SEP2016		ITEM NAME ASSEMBLY, FIRE PUMP CFP5E-F10/20/30/40/50	CAD SHEET 1 OF 3
THIS DOCUMENT (AND THE INFORMATION SHOWN THEREON) IS CONFIDENTIAL AND PROPRIETARY AND SHALL NOT BE DISCLOSED TO OTHERS IN HARD COPY OR ELECTRONIC FORM, REPRODUCED BY ANY MEANS, OR USED FOR ANY PURPOSE WITHOUT WRITTEN CONSENT OF CUMMINS INC.			FOR INTERPRETATION OF DIMENSIONING AND TOLERANCING, SEE ASME Y14.5-2009	MUST CONFORM TO CES 10903	REV 2



REV	REL NO	REVISION	DWN	CKD	APVD	DATE
A	2017-137	SEE SHEET 1 FOR REVISION DETAILS	HE392	-	-	07MAR17
2	2019-580	SEE SHEET 1 FOR REVISION DETAILS	NO134	MS707	MS707	03DEC19

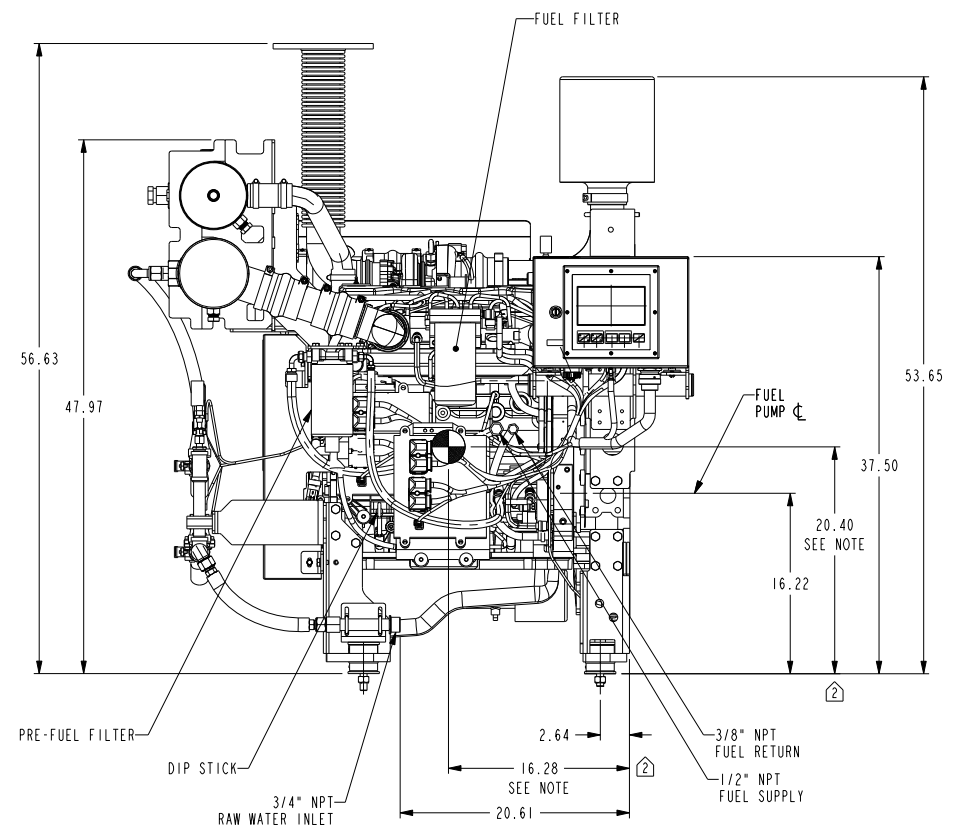
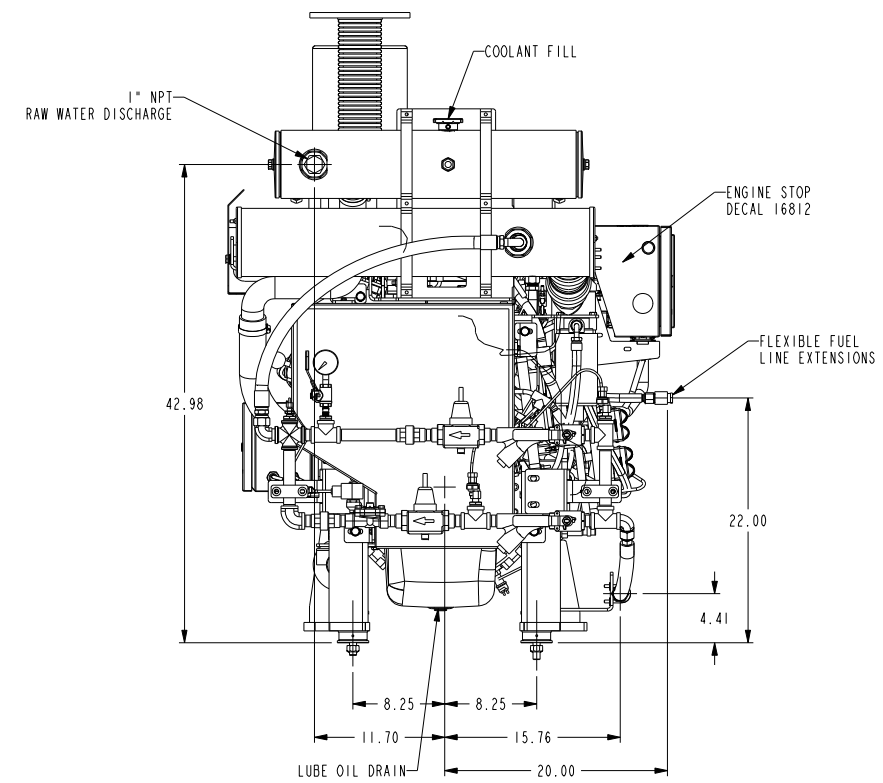
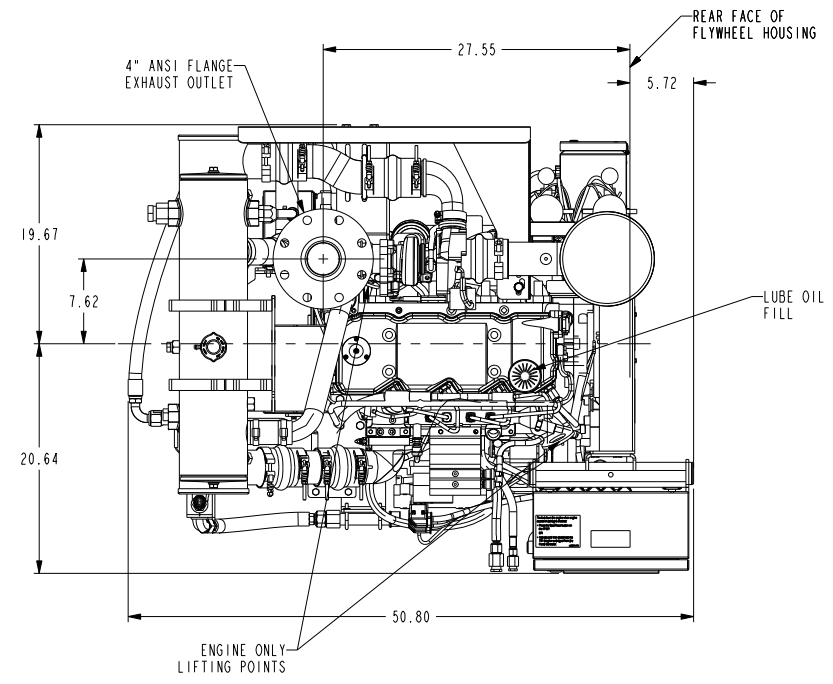

NOTES:  
1. CENTER OF GRAVITY LOCATION IS APPROXIMATE

DIMENSIONS ARE IN: INCHES 1:1 ARE IN:	<b>DO NOT SCALE PRINT</b> SCALE 0.125	CMI DATA CLASSIFICATION Cummins Confidential		<b>Cummins Inc.</b>	
				ITEM NAME ASSEMBLY, FIRE PUMP CFP5E-F10/20/30/40/50	
DRAWING TOLERANCES APPLY TO PRIMARY DIMENSIONS UNLESS OTHERWISE SPECIFIED F: ± 0.004 IN OR 0.10 mm M: ± 0.003 IN OR 0.075 mm L: ± 0.002 IN OR 0.050 mm H: ± 0.001 IN OR 0.025 mm ANGULAR TOLERANCE: ± 0.005	DWN: HE392 CKD: APVD: NE627 DATE: 16SEP2016	FOR INTERPRETATION OF DIMENSIONING AND TOLERANCING, SEE ASME Y14.5-2009	MUST CONFORM TO CES 10903	CAD SHEET 2 OF 3	ITEM NUMBER A042H676
					REV 2

REV	REL NO	REVISION	DWN	CKD	APVD	DATE
A	2017-137	SEE SHEET 1 FOR REVISION DETAILS	HE392	-	-	07MAR17
2	2019-580	SEE SHEET 1 FOR REVISION DETAILS	NO134	MS707	MS707	03DEC19

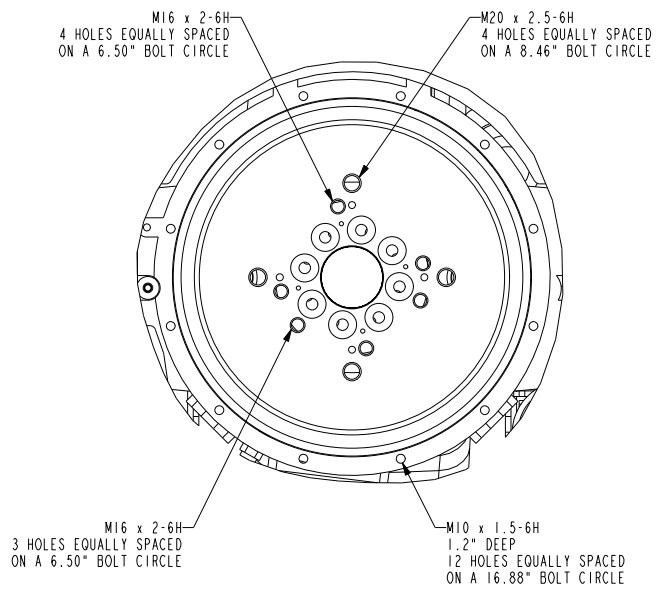
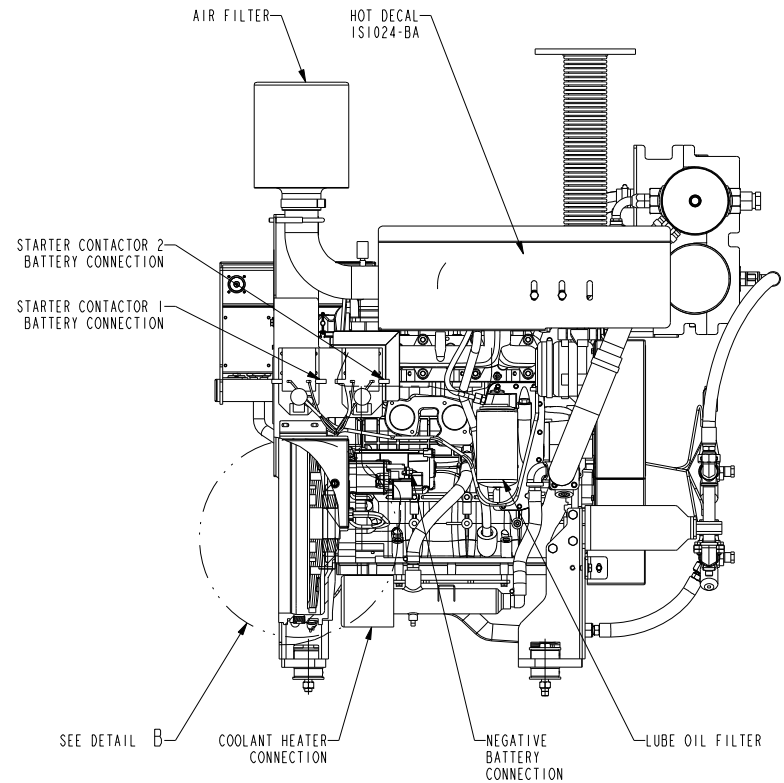
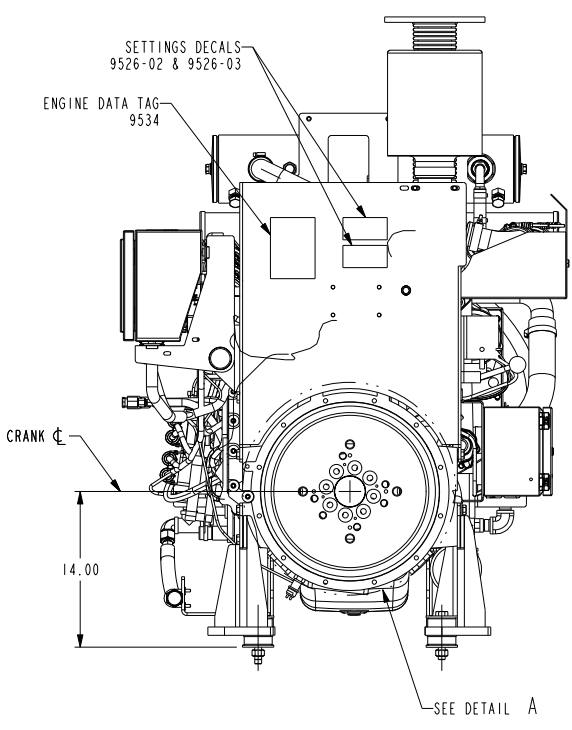

DETAIL A  
SCALE 0.250

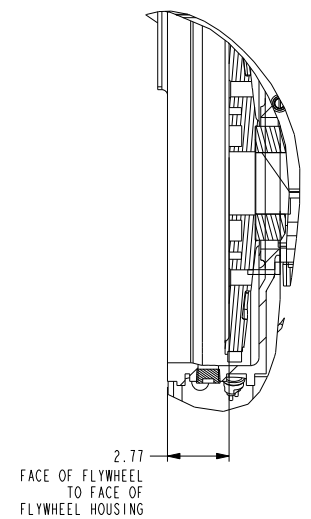

DETAIL B  
SCALE 0.250

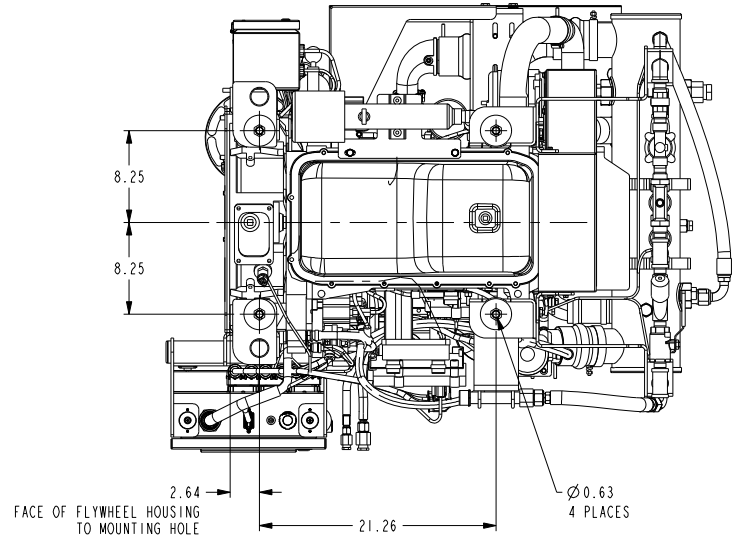

DIMENSIONS ARE IN: INCHES 1: ARE IN:	<b>DO NOT SCALE PRINT</b> SCALE 0.125	CMI DATA CLASSIFICATION Cummins Confidential		<b>Cummins Inc.</b>	
				ITEM NAME ASSEMBLY, FIRE PUMP CFP5E-F10/20/30/40/50	
DRAWING TOLERANCES APPLY TO PRIMARY DIMENSIONS UNLESS OTHERWISE SPECIFIED F: ± .1 IN OR 4 mm X: ± .1 IN OR 3 mm H: ± .03 IN OR 0.25 mm L: ± .010 IN OR 0.25 mm ANGULAR TOLERANCE: ± 2°	FOR INTERPRETATION OF DIMENSIONING AND TOLERANCING, SEE ASME Y14.5-2009	MUST CONFORM TO CES 10903	CAD SHEET 3 OF 3	ITEM NUMBER A042H676	REV 2

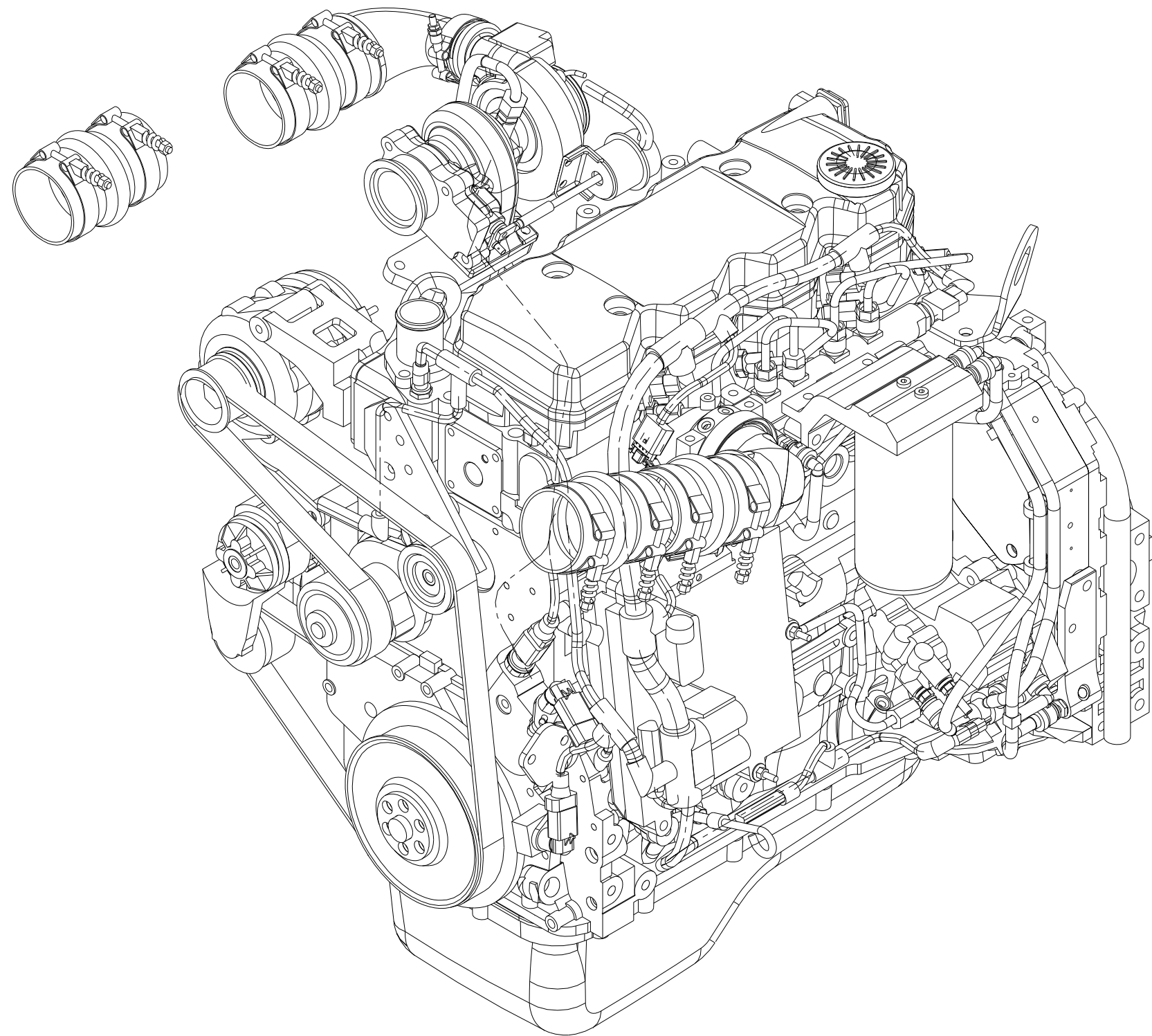

ENGINE ASSEMBLY  
 QSB 4.5 L  
 FIREPUMP CONFIGURATION  
 FIRE 45 QSB4.5 BASE ENGINE

E	AP90116	APPROVAL AGENCY		LA 9110	ARRANGEMENT, LIFTING
	BR 9191	BREATHER, CRANKCASE		LF 9136	FILTER, FULL FLOW OIL
	CH 9093	AID, COOLANT HEATER STARTING		LG 9998	GAUGE, OIL LEVEL
	DL 9253	LOCATION, FUEL DRAIN		LO 9015	OIL, LUBRICATING
	DO92738	SOFTWARE, CUSTOMER INTERFACE		OB 9169	ARRANGEMENT, OIL FILL
	DR 9020	DRIVE, REAR GEAR TRAIN		OP 9454	PAN, OIL
F	EE 9301	ALTERNATOR		RP 9045	VENT, ENGINE COOLANT
	EH 9472	MOUNTING, ALTERNATOR		SK 9003	ARRANGEMENT, SHIPPING
	FA 9330	FAN DRIVE		SS 9591	PAINT
	FF 9674	LOCATION, FUEL FILTER	F	ST 9487	MOTOR, STARTING
	FH 9469	HOUSING, FLYWHEEL		SV 9001	VOLTAGE, ENGINE OPERATING
	FI 9099	FITTING, FUEL INLET		TB91170	ARRANGEMENT, TURBO CHARGER
	FR93662	RATING, FUEL		TK 9036	COOLER, TORQUE CONVERTER OIL
	FW 9829	FLYWHEEL		VC 9310	ARRANGEMENT, VALVE COVER
	HC 9040	PLUMBING, CABIN HEATER		WI 9179	CONNECTION, WATER INLET
	IC 9480	CONNECTION, AIR INTAKE	D	WO 9143	CONNECTION, WATER OUTLET
	IT 9087	CONNECTION, AIR TRANSFER		XS 9254	CONNECTION, EXHAUST OUTLET
	LT 9366	LITERATURE		IC 9288	CONNECTION, HOSES, CAC

This document contains confidential and trade secret information, is the property of Cummins Fire Power LLC and is given to the receiver in confidence. The receiver, by receiving and retaining of the document accepts the document in confidence and agrees that, except as authorized in writing by Cummins NPower, it will (1) not use the document or any copy thereof or the confidential or trade secret information therein, (2) not copy the document, (3) not disclose to others either the document or the confidential or trade secret information therein, and (4) upon completion of the need to retain the document, or upon demand, return the document, all copies thereof, and all material copied therefrom. COPYRIGHT Cummins Fire Power LLC



CUMMINS FIRE POWER LLC  
 CORPORATE OFFICE  
 1600 BUERKLE ROAD  
 WHITE BEAR LAKE, MN  
 WWW.CUMMINSFIREPOWER.COM

CUSTOM DESIGN  
 AND UPFIT CENTER  
 875 LAWRENCE DRIVE  
 DEPERE, WISCONSIN

ASSEMBLY, ENGINE, QSB4.5

UNLESS OTHERWISE SPECIFIED ALL DIMENSION TOLERANCES ARE

ANGULAR DIMENSIONS ± 1°	MACHINED SURFACES	IMPERIAL UNITS	METRIC UNITS
THIRD ANGLE PROJECTION	125	MACHINE TOLERANCES .XX ± 0.010 .XXX ± 0.005	MACHINE TOLERANCES .X ± 0.4 .XX ± 0.2
		FORM TOLERANCES .XX ± 0.030 .XXX ± 0.015	FORM TOLERANCES .X ± 0.8 .XX ± 0.4
		FAB TOLERANCES .XX ± 0.060 .XXX ± 0.030	FAB TOLERANCES .X ± 1.5 .XX ± 0.8

F	2016-786	ENGINE SPEC UPDATED	PBS	18NOV2016
E	2014-679	ENGINE SPEC UPDATED	JJW	29SEP2014
D	2010-367	UPDATED WO OPTION	S DUBICK	04AUG2010
REV	ECO	DESCRIPTION OF REVISION	REV BY	DATE

DWG UNITS:	DRAWN BY: MAC	DATE: 10-SEP-09
	<b>PRO-ENGINEER</b>	INIT ECO:
SCALE: 0.200	SHEET 1 OF 1	DRAWING NO: 13211
EST WEIGHT: 0.000		

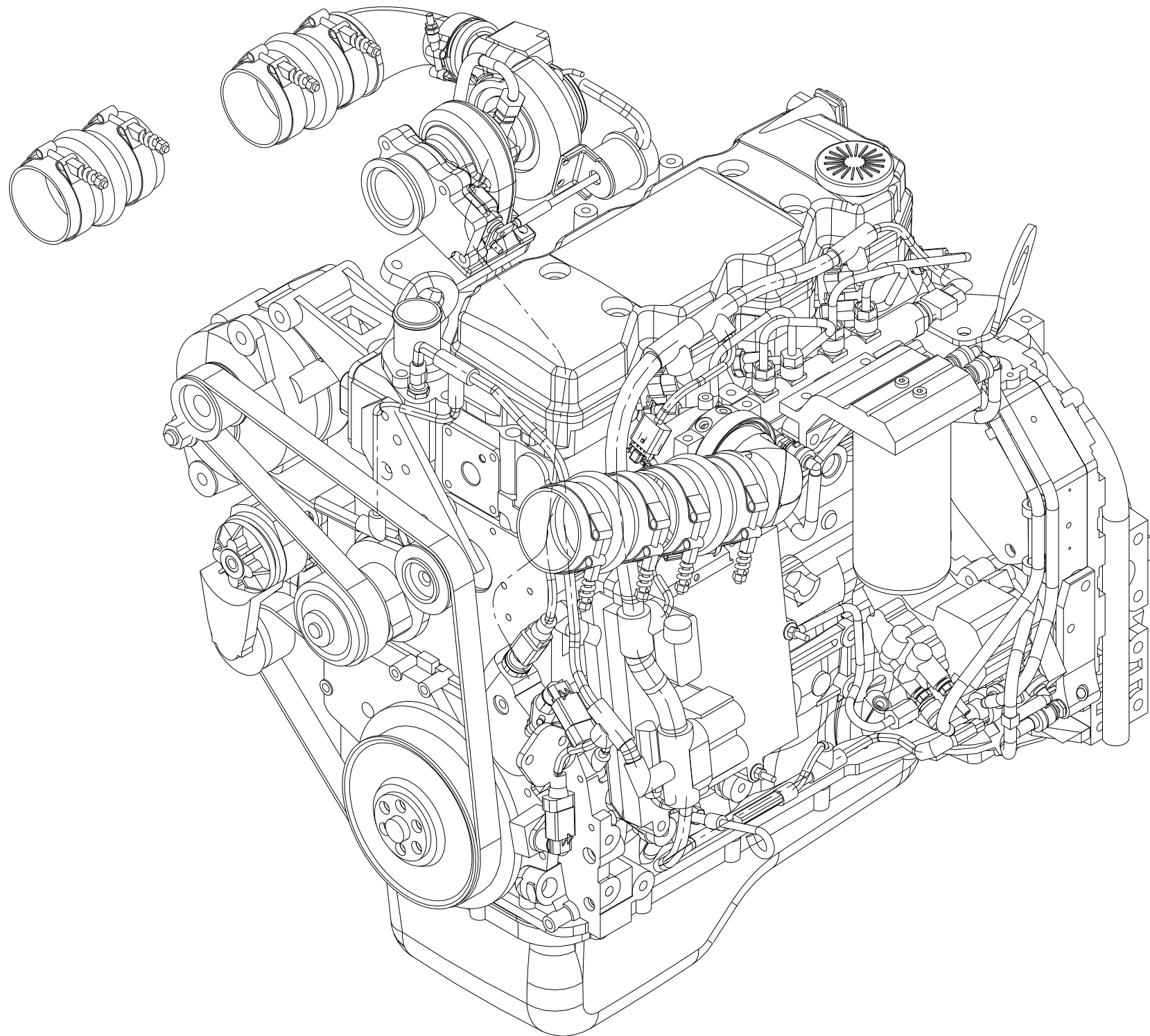

D C B A

ENGINE ASSEMBLY  
 QSB 4.5 L  
 FIREPUMP CONFIGURATION  
 FIRE 45 QSB4.5 BASE ENGINE

AP90116	APPROVAL AGENCY	LA 9110	ARRANGEMENT, LIFTING
BR 9191	BREATHER, CRANKCASE	LF 9136	FILTER, FULL FLOW OIL
CH 9093	AID, COOLANT HEATER STARTING	LG 9998	GAUGE, OIL LEVEL
DL 9253	LOCATION, FUEL DRAIN	LO 9015	OIL, LUBRICATING
DO92825	SOFTWARE, CUSTOMER INTERFACE	OB 9169	ARRANGEMENT, OIL FILL
DR 9020	DRIVE, REAR GEAR TRAIN	OP 9454	PAN, OIL
EE 9247	ALTERNATOR	RP 9045	VENT, ENGINE COOLANT
EH 9469	MOUNTING, ALTERNATOR	SK 9003	ARRANGEMENT, SHIPPING
FA 9330	FAN DRIVE	SS 9591	PAINT
FF 9674	LOCATION, FUEL FILTER	ST 9658	MOTOR, STARTING
FH 9469	HOUSING, FLYWHEEL	SV 9002	VOLTAGE, ENGINE OPERATING
FI 9099	FITTING, FUEL INLET	TB91170	ARRANGEMENT, TURBO CHARGER
FR91601	RATING, FUEL	TK 9036	COOLER, TORQUE CONVERTER OIL
LT9366	LITERATURE	VC 9310	ARRANGEMENT, VALVE COVER
FW 9829	FLYWHEEL	WI 9179	CONNECTION, WATER INLET
HC 9040	PLUMBING, CABIN HEATER	WO 9143	CONNECTION, WATER OUTLET
IC 9480	CONNECTION, AIR INTAKE	XS 9254	CONNECTION, EXHAUST OUTLET
IC 9288	CONNECTION, HOSE, CAC	IT 9087	CONNECTION, AIR TRANSFER

This document contains confidential and trade secret information, is the property of Cummins Fire Power LLC and is given to the receiver in confidence. The receiver, by receiving and retaining of the document accepts the document in confidence and agrees that, except as authorized in writing by Cummins NPower, it will (1) not use the document or any copy thereof or the confidential or trade secret information therein, (2) not copy the document, (3) not disclose to others either the document or the confidential or trade secret information therein, and (4) upon completion of the need to retain the document, or upon demand, return the document, all copies thereof, and all material copied therefrom. COPYRIGHT Cummins Fire Power LLC



CUMMINS FIRE POWER LLC  
 CORPORATE OFFICE  
 1600 BUERKLE ROAD  
 WHITE BEAR LAKE, MN  
 WWW.CUMMINSFIREPOWER.COM

CUSTOM DESIGN  
 AND UPFIT CENTER  
 875 LAWRENCE DRIVE  
 DEPERE, WISCONSIN

ASSEMBLY, ENGINE, 24 VOLT QSB4.5

D	2016-786	ENGINE SPEC UPDATED	PBS	18NOV2016
C	2014-679	AP90116 REPLACED AP9510, DO92825 REPLACED DO90028 & WO9143 REPLACED WO9064	JJW	26SEP2014
B	2010-317	ADDED IC9288	S DUBICK	20JUL2010
A	2010-115	ADDED LT9366	S DUBICK	18MAR2010
REV	ECO	DESCRIPTION OF REVISION	REV BY	DATE

UNLESS OTHERWISE SPECIFIED ALL DIMENSION TOLERANCES ARE

ANGULAR DIMENSIONS ± 1°	MACHINED SURFACES	IMPERIAL UNITS	METRIC UNITS
THIRD ANGLE PROJECTION	125	MACHINE TOLERANCES .XX ± 0.010 .XXX ± 0.005	MACHINE TOLERANCES .X ± 0.4 .XX ± 0.2
		FORM TOLERANCES .XX ± 0.030 .XXX ± 0.015	FORM TOLERANCES .X ± 0.8 .XX ± 0.4
		FAB TOLERANCES .XX ± 0.060 .XXX ± 0.030	FAB TOLERANCES .X ± 1.5 .XX ± 0.8

DWG UNITS: IN/LB/S	DRAWN BY: MAC <b>PRO-ENGINEER</b>	DATE: 01-08-2009 INIT ECO:
SCALE: 0.200	SHEET 1 OF 1	DRAWING NO: 13211-24
EST WEIGHT: 0.000		



BILL OF MATERIAL			
ITEM	QTY	DESCRIPTION	PART NUMBER
1	1	ASSEMBLY, MODIFIED VALVE COVER, CFP_5E	13852
2	1	SWITCH, PROXIMITY, 2M CABLE, 12-24V	12865
3	1	WASHER, PRESSURE SEALING WASHER, -	13769

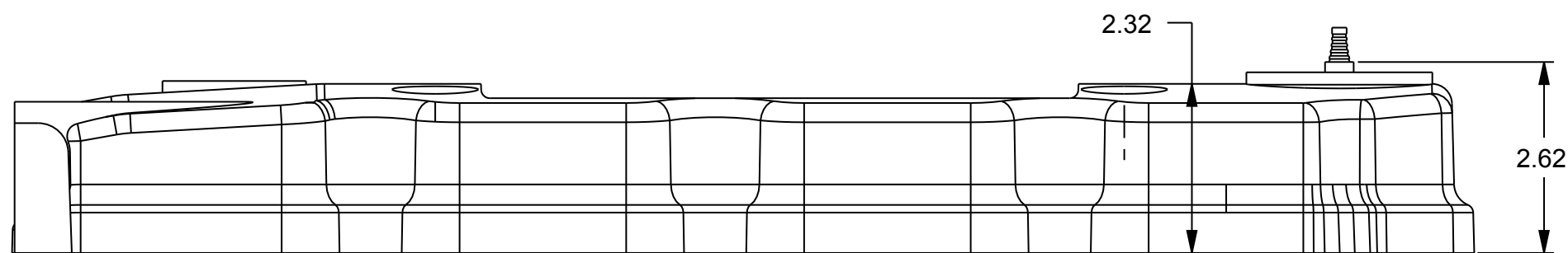
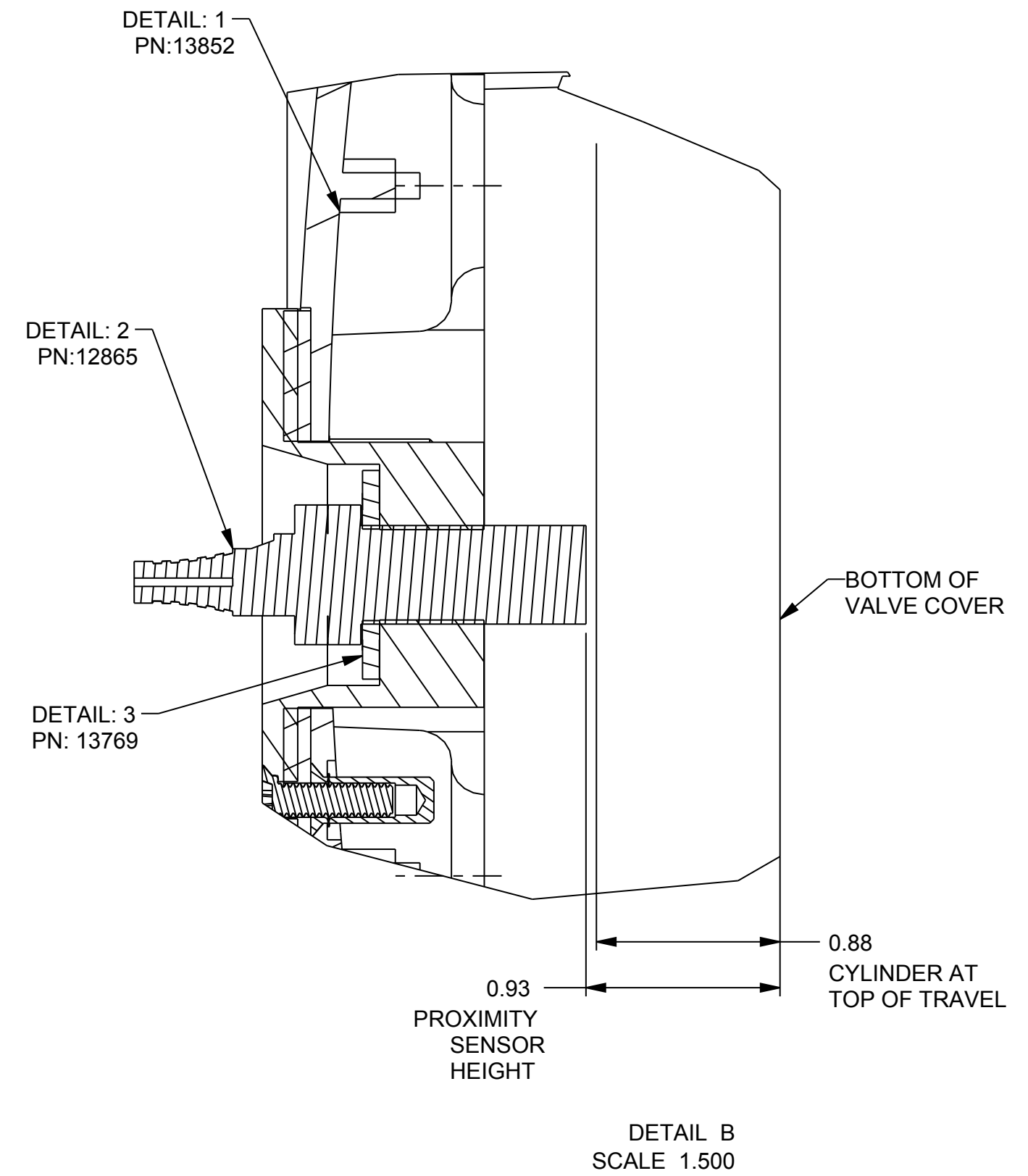
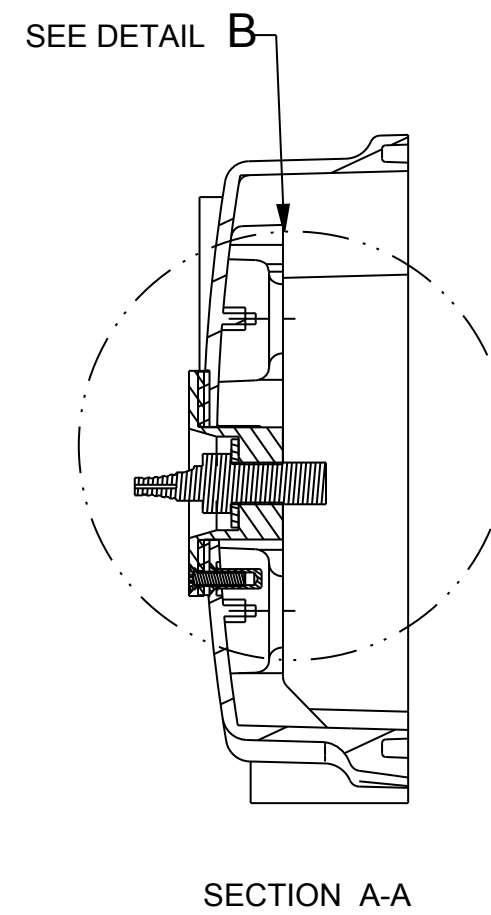
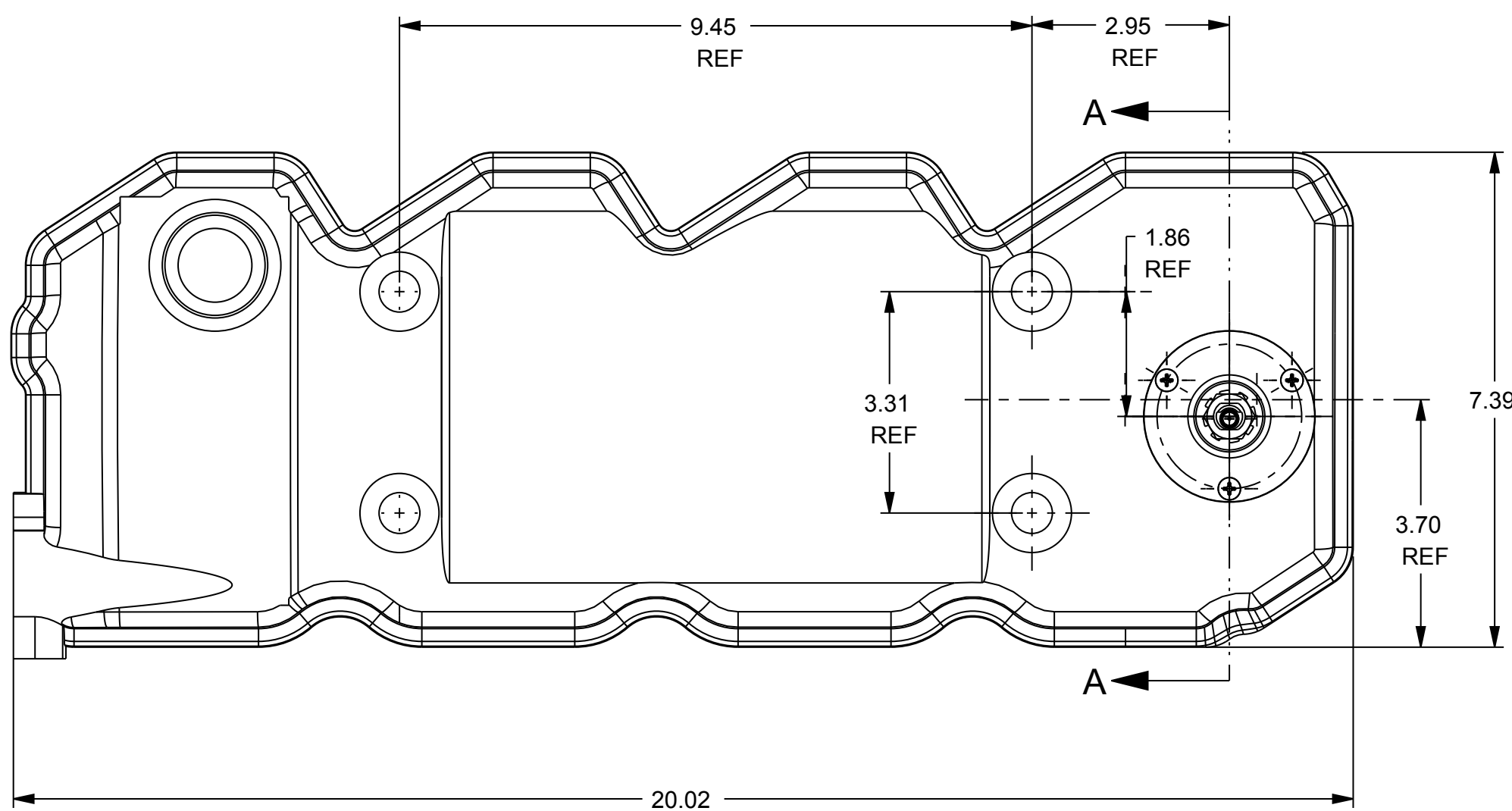

This document contains confidential and trade secret information, is the property of Cummins Fire Power LLC and is given to the receiver in confidence. The receiver, by receiving and retaining of the document accepts the document in confidence and agrees that, except as authorized in writing by Cummins Fire Power, it will (1) not use the document or any copy thereof or the confidential or trade secret information therein, (2) not copy the document, (3) not disclose to others either the document or the confidential or trade secret information therein, and (4) upon completion of the need to retain the document, or upon demand, return the document, all copies thereof, and all material copied therefrom. COPYRIGHT Cummins Fire Power LLC.

**Cummins Fire Power**  
 CUMMINS FIRE POWER LLC  
 CORPORATE OFFICE  
 1600 BLUERKLE ROAD  
 WHITE BEAR LAKE, MN  
 WWW.CUMMINSFIREPOWER.COM

CUSTOM DESIGN  
 AND UPFIT CENTER  
 875 LAWRENCE DRIVE  
 DEPERE, WISCONSIN

UNLESS OTHERWISE SPECIFIED ALL DIMENSION TOLERANCES ARE:		ASSEMBLY, VALVE COVER PROXIMITY LOCATION CFP_5E
ANGULAR DIMENSIONS ±°	IMPERIAL UNITS	METRIC UNITS
THIRD ANGLE PROJECTION	MACHINE TOLERANCES XX+/- .010 XX+/- .008	MACHINE TOLERANCES XX+/- .02 XX+/- .01
	FORM TOLERANCES XX+/- .010 XX+/- .008	FORM TOLERANCES XX+/- .02 XX+/- .01
	FAB TOLERANCES XX+/- .008 XX+/- .005	FAB TOLERANCES XX+/- .02 XX+/- .01
DWG UNITS: IN/LB/S	DRAWN BY: MAC PRO-ENGINEER	DATE: 12-16-2008 REF DRWG: _
SCALE: 0.460 EST WEIGHT: 25572.168	SHEET 1 OF 1	DRAWING NO: 13772

REV	ENF	DESCRIPTION OF REVISION	REV BY	DATE
A				

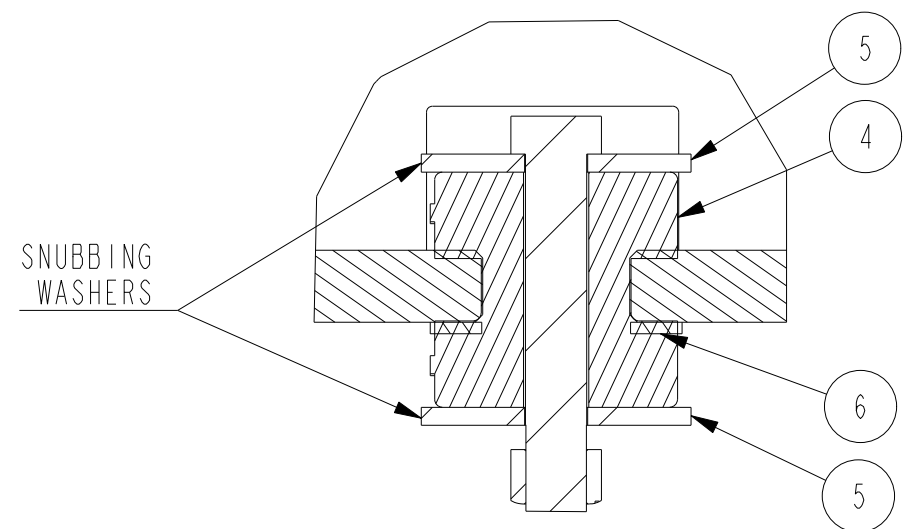
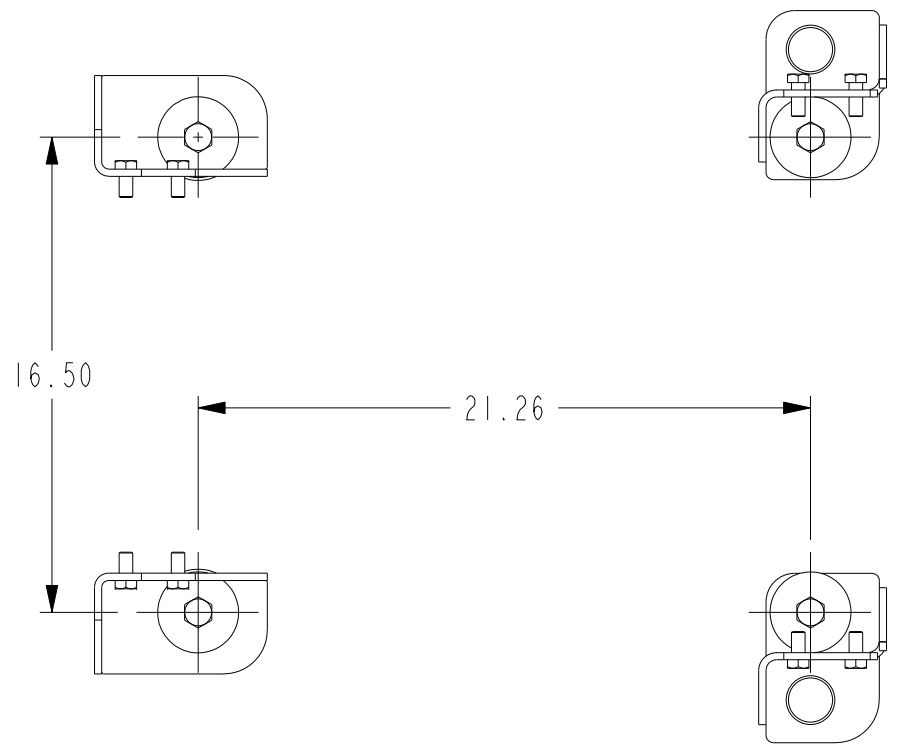

BILL OF MATERIAL			
ITEM	QTY	DESCRIPTION	PART NUMBER
1	2	LEG, ENGINE REAR, ISOLATED CFP5E	13344
2	1	LEG, ENGINE FRONT LH, ISOLATED CFP5E	14349
3	1	LEG, ENGINE FRONT RH, ISOLATED CFP5E	14350
4	4	ISOLATOR, TECH PRODUCTS #60035, FIREPUMP	13340
E	5	8 WASHER, SNUBBING, TECH PRODUCTS 0183	13598
6	4	SHIM, ISOLATED, LEG, FIREPUMP	14348
7	4	NUT, HEX, PT, M16-2.00	20140-M16
8	10	SCREW, HH, M12-1.75x25	20312-025
9	4	SCREW, HH, M12-1.75x30	20312-030
10	3	SCREW, HH, M16-2.00x100	20316-100
11	1	SCREW, HH, M16-2.00x110	20316-110

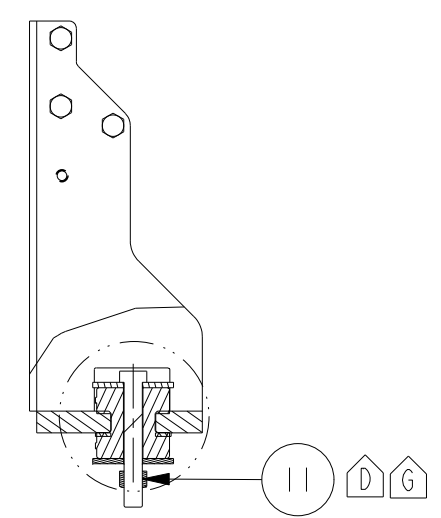

SECTION A-A

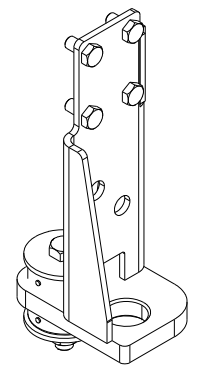
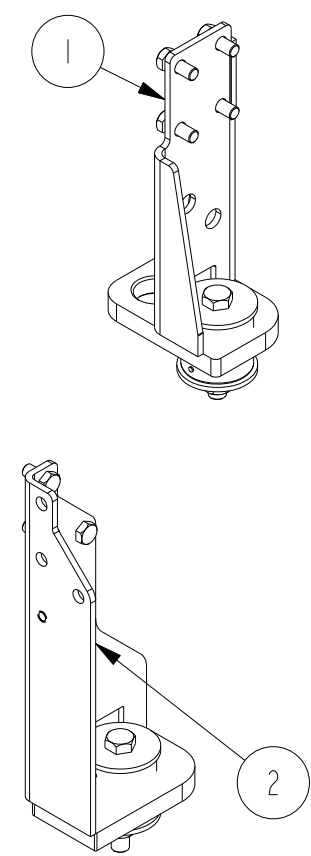
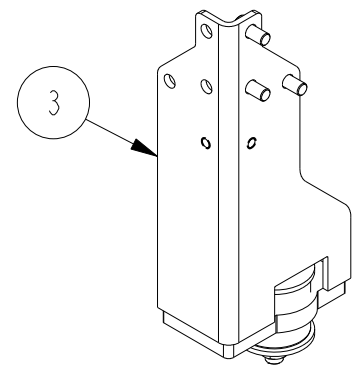
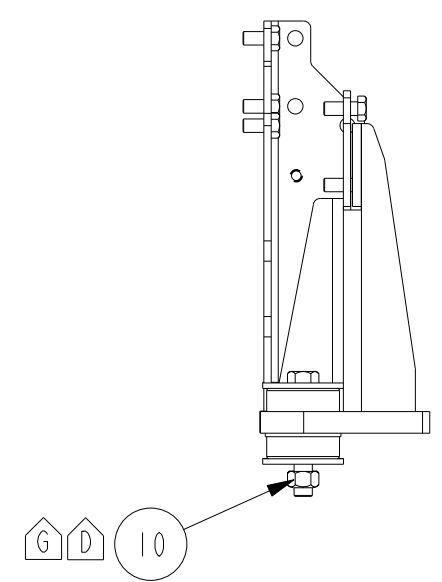
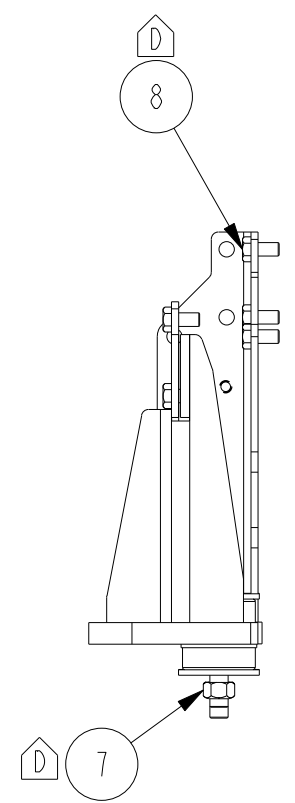

ITEM #6 LEG SHIM MUST BE INSTALLED ON EACH LEG

REV	ECO	DESCRIPTION OF REVISION	REV BY	DATE
G	2015-306	DELETED: 20316-090, ADDED 20316-110 20316-100 WAS QTY 1	PBS	12MAY2015
F	2014-076	DELETED: 14370	PBS	06FEB2014
E	2011-275	CREATE NUMBER AND ADD SNUBBING WASHERS.	S DUBICK	29-AUG-11
D	2011-054	ADD FASTENERS PER SIX SIGMA	S DUBICK	26-APR-11
C	2011-043	REV PER COMPONENTS, ADDED SECTION VIEW.	S DUBICK	01-FEB-11

This document contains confidential and trade secret information, is the property of Cummins Fire Power LLC and is given to the receiver in confidence. The receiver, by receiving and retaining of the document accepts the document in confidence and agrees that, except as authorized in writing by Cummins NPower, it will (1) not use the document or any copy thereof or the confidential or trade secret information therein, (2) not copy the document, (3) not disclose to others either the document or the confidential or trade secret information therein, and (4) upon completion of the need to retain the document, or upon demand, return the document, all copies thereof, and all material copied therefrom. COPYRIGHT Cummins Fire Power LLC

UNLESS OTHERWISE SPECIFIED ALL DIMENSION TOLERANCES ARE

ANGULAR DIMENSIONS ± 1°

THIRD ANGLE PROJECTION

MACHINED SURFACES

IMPERIAL UNITS

METRIC UNITS

MACHINE TOLERANCES  
.XX ± 0.010  
.XXX ± 0.005

FORM TOLERANCES  
.XX ± 0.030  
.XXX ± 0.015

FAB TOLERANCES  
.XX ± 0.060  
.XXX ± 0.030

MACHINE TOLERANCES  
.X ± 0.4  
.XX ± 0.2

FORM TOLERANCES  
.X ± 0.8  
.XX ± 0.4

FAB TOLERANCES  
.X ± 1.5  
.XX ± 0.8

**Cummins Fire Power**

CUMMINS FIRE POWER LLC  
CORPORATE OFFICE  
1600 BUERKLE ROAD  
WHITE BEAR LAKE, MN  
WWW.CUMMINSFIREPOWER.COM

CUSTOM DESIGN  
AND UPFIT CENTER  
875 LAWRENCE DRIVE  
DEPERE, WISCONSIN

ASSEMBLY, ENGINE MOUNTING  
ISOLATED, CFP5E

DWG UNITS: IN/LB/S  
SCALE: 0.150  
EST WEIGHT: 64.732

DRAWN BY: MAC  
**PRO-ENGINEER**

DATE: 11-05-2008  
INIT ECO:

SHEET 1 OF 1

DRAWING NO: 13847

BILL OF MATERIAL			
ITEM	QTY	DESCRIPTION	PART NUMBER
1	1	PIPE, WATER OUTLET; FIRE PUMP	13305
2	1	TUBE, CAC INTAKE CONNECTION; CFPSE / 7E	13348
3	1	PIPE, WATER INLET; FIRE PUMP	A042A659
4	1	TUBE, CAC OUTPUT; CFPSE	A042A665
5	1	BRACKET, HEAT EXCHANGER; MOUNTING, CFPSE/7E	A042H705
6	3	COOLANT, FC EG PM, 1 GALLON;	CC2743
7	1	CONNECTOR, FEMALE; -16 ORB X -16 FNPT, STEEL	12171-16-16
8	3	UNION, MALE; -12 JIC X -12 ORB, STEEL	12235-12-12
9	2	CLAMP, SPRING LOADED T-BOLT; 3.28-3.58	12975-0350
10	1	HEAT EXCHANGER, 6" DIAMETER; 2-PASS W/ INTEGRAL TOP TANK	13243
11	1	COOLER, CHARGE AIR, 6" DIAMETER; 1-PASS W/ WATER DRAIN	13244
12	4	CLAMP, HOSE; 1.31 - 2.25 WORM	14990-28
13	4	CLAMP, HOSE; 1.56 - 2.50 WORM	14990-32
14	1	PLUG, PIPE; -16 (1") NPT, PVC	15255-16
15	1	CAPLUG, PLASTIC, JIC FEMALE; 1-1/16-12	16660-12
16	2	PLATE, HEAT EXCHANGER MOUNTING; CFPSE/7E	16726
17	2	PLATE, HEAT EXCHANGER MOUNTING; CFPSE/7E	16727
18	1	WASHER, PLAIN; 0.31, B18.21.1 TYPE A, NRW	20010-031
19	4	SCREW, HEX HEAD CAP; M8-1.25x25, 8.8MM, ZINC	20308-025
20	3	SCREW, HEX HEAD CAP; M10-1.50x25, 8.8MM, ZINC	20310
21	1	HOSE, FUEL LINE, 5/16ID; 48"L	27003
22	1	SIGHT GLASS, 1/2" NPT;	3277K34
23	1	CLAMP, U-BOLT; 2" OD PIPE	89541K
24	1	HOSE, PLAIN; 1.75 ID X 4.00 LG EPDM	A042F053
25	1	HOSE, PLAIN; 1.75 ID X 5.00 LG EPDM	A042F053
26	1	HOSE, PLAIN; 2.00 ID X 5.00 LG EPDM	A042F054
27	1	HOSE, 90 DEGREE; SWEEP, 2" I.D., 2.25" O.D.	E70739

REV	REL NO	REVISION	DWN	CKD	APVD	DATE
-	2016-376	INITIAL RELEASE	PBS			07SEP16
A	2018-229	REPLACED E70739 WITH 21379	LO629			23APR18
2	2020-019	ADDED NOTES; REMOVED 16825	RE123	MS707	MS707	22JAN20

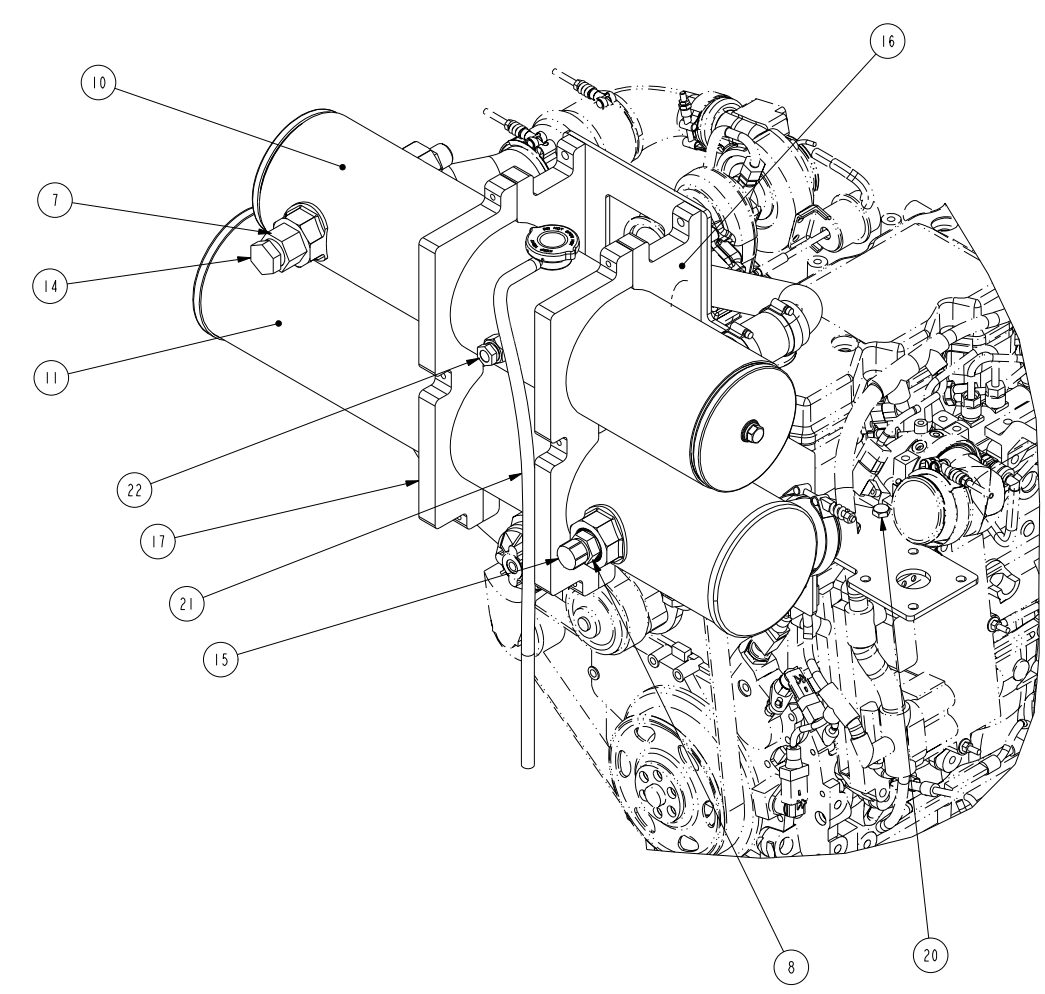
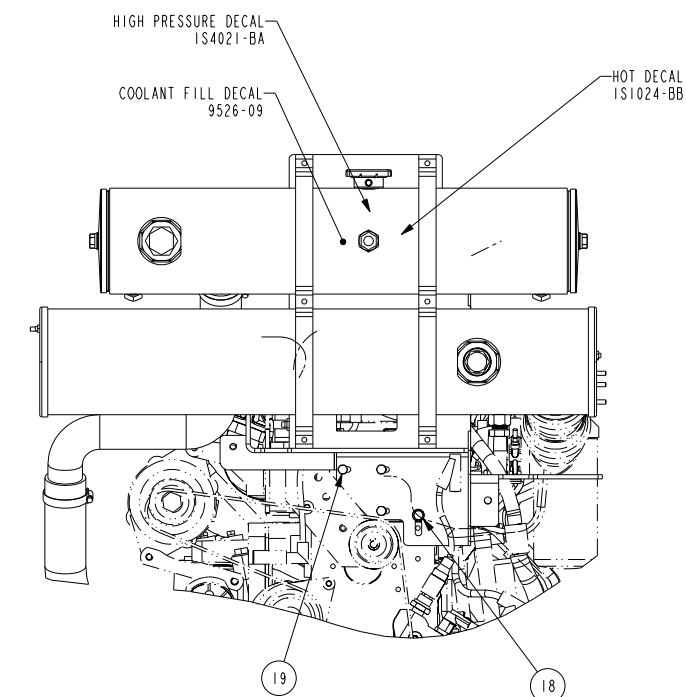
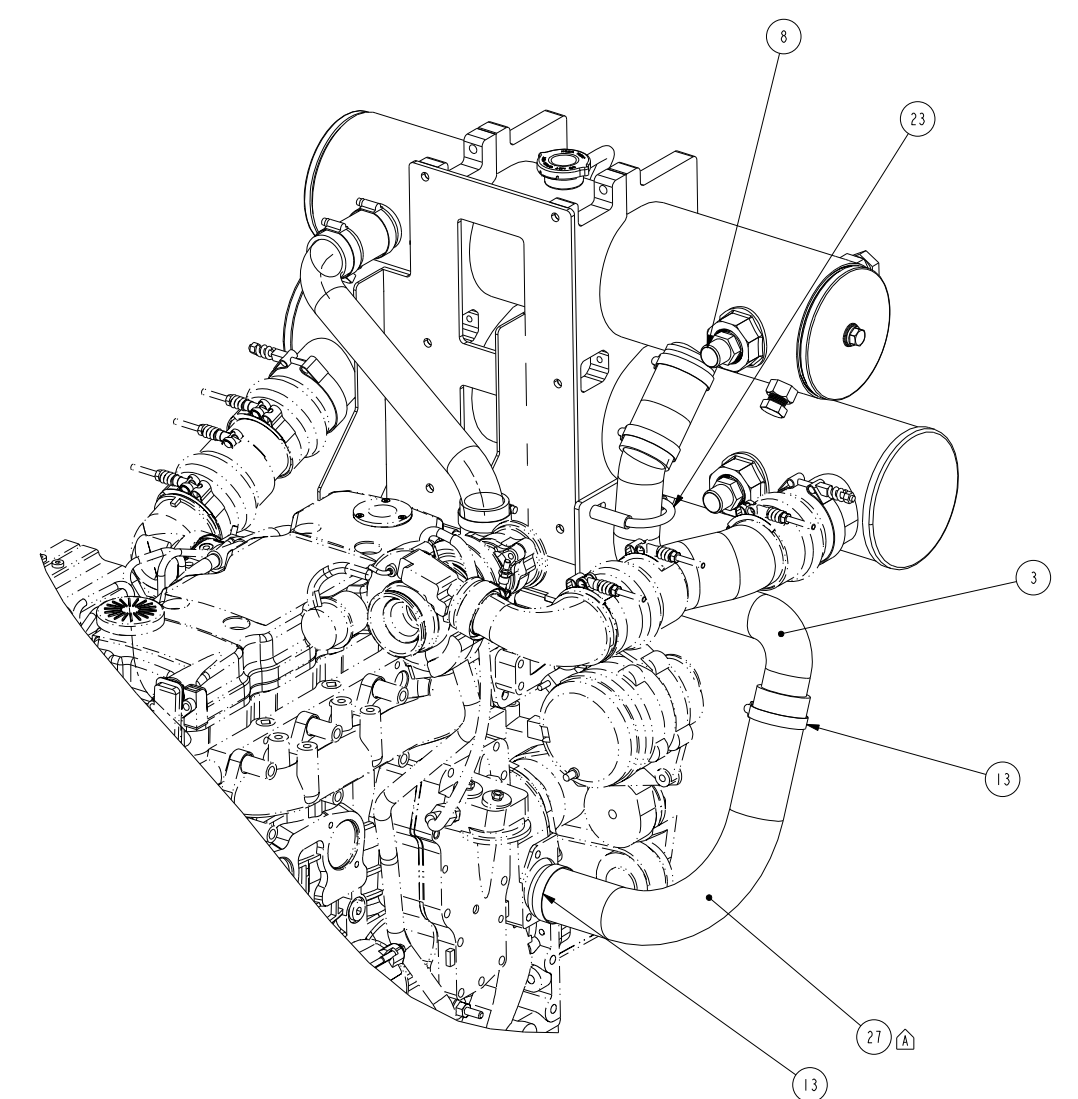
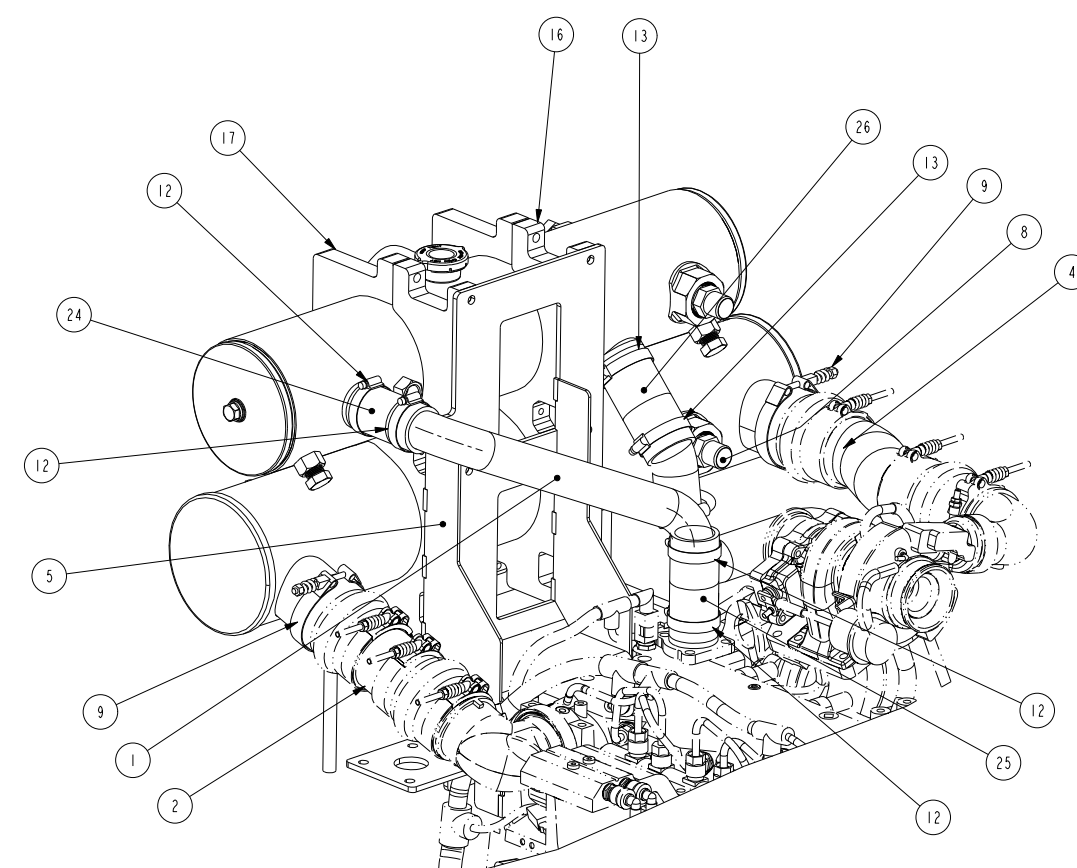

NOTES:  
 1. HUMP HOSES (4) AND CLAMPS (8) COME WITH ENGINE, ONLY 6 OF THE 8 CLAMPS WILL BE USED AND THE OTHER 2 ARE TO BE DISCARDED

DIMENSIONS ARE IN: INCHES [ ] ARE IN: -	DO NOT SCALE PRINT SCALE 0.250	CWI DATA CLASSIFICATION Cummins Confidential		Cummins Inc.	
DRAWING TOLERANCES APPLY TO PRIMARY DIMENSIONS UNLESS OTHERWISE SPECIFIED X.1: ± .1 IN OR 4 mm X.2: ± .1 IN OR 3.1 mm X.3: ± .030 IN OR 0.75 mm X.4: ± .010 IN OR 0.25 mm ANGULAR TOLERANCE: ±	DATE: 07SEP16	FOR INTERPRETATION OF DIMENSIONING AND TOLERANCING: SEE ASME Y14.5-2009		MUST CONFORM TO CES 10903	ITEM NAME ASSEMBLY, HEAT EXCHANGERS CFPSE
<small>THIS DOCUMENT AND THE INFORMATION SHOWN THEREON IS CONFIDENTIAL AND PROPRIETARY AND SHALL NOT BE DISCLOSED TO OTHERS IN HARD COPY OR ELECTRONIC FORM, REPRODUCED BY ANY MEANS, OR USED FOR ANY PURPOSE WITHOUT WRITTEN CONSENT OF CUMMINS INC.</small>				CAD SHEET 1 OF 1	REV 2

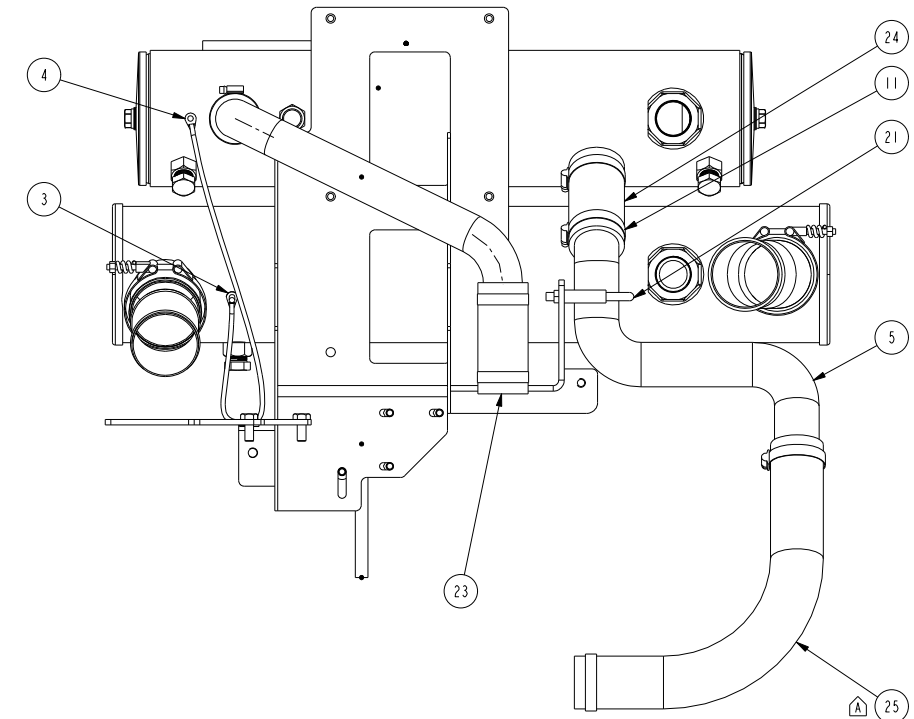
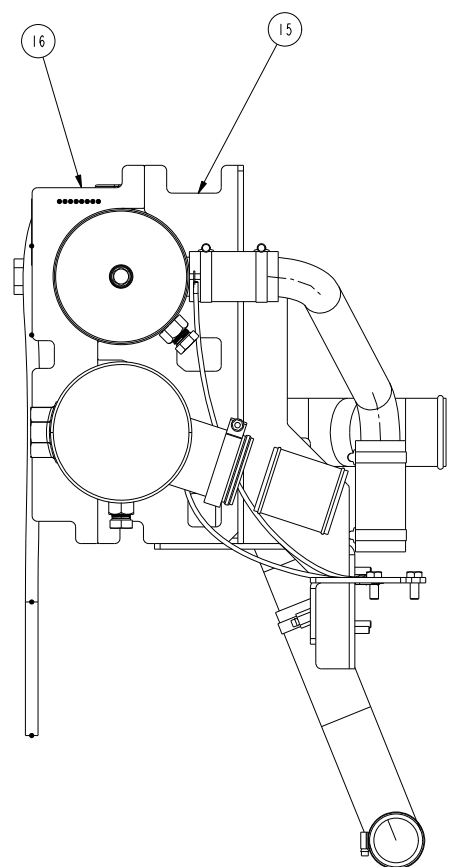
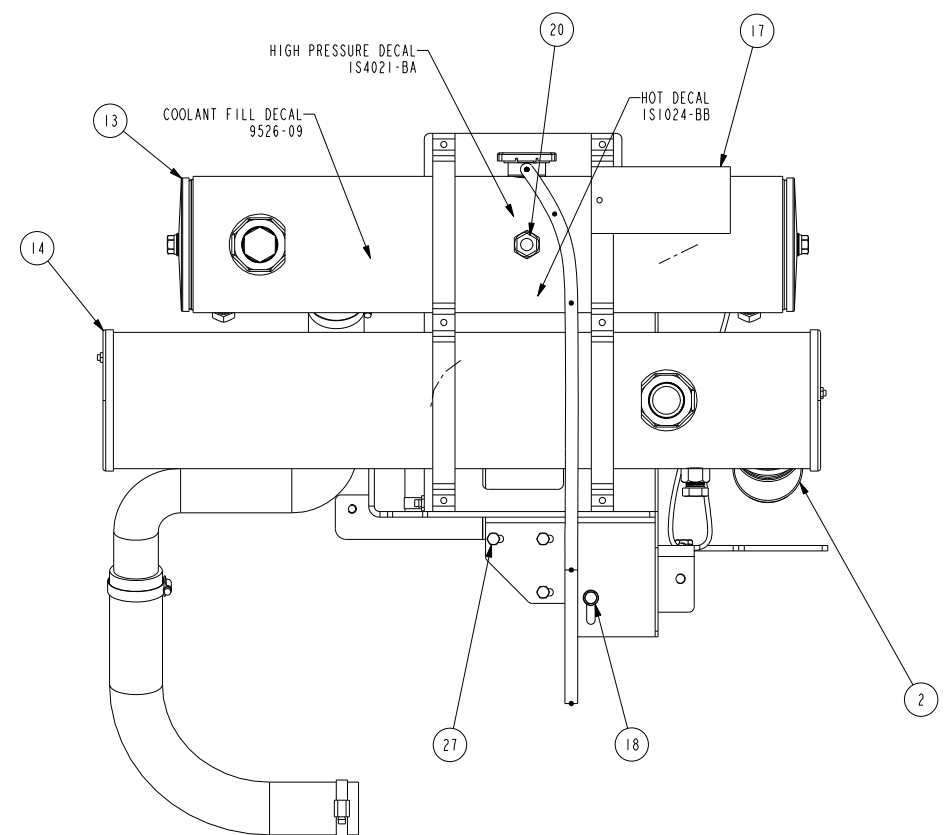
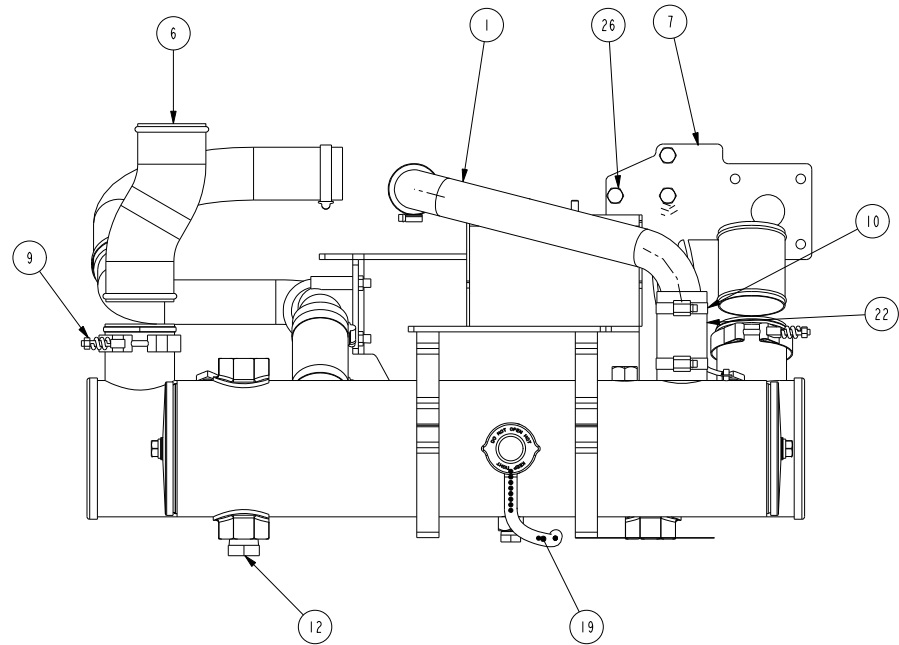

BILL OF MATERIAL			
ITEM	QTY	DESCRIPTION	PART NUMBER
1	1	PIPE, WATER OUTLET; FIRE PUMP	13305
2	1	TUBE, CAC INTAKE CONNECTION; CFPSE / 7E	13348
3	1	GROUND STRAP, 1/4" BRAID; 12" LONG, 1/4" & 1/2" TERMINALS	15813
4	1	GROUND STRAP, 1/4" BRAID; 18" LONG, 1/4" & 1/2" TERMINALS	15814
5	1	PIPE, WATER INLET; FIRE PUMP	A042A659
6	1	TUBE, CAC OUTPUT; CFPSE	A042A665
7	1	BRACKET, HEAT EXCHANGER MOUNTING; CFPSE/7E	A042H705
8	3	COOLANT, FC EG PM, 1 GALLON;	CC2743
9	2	CLAMP, SPRING LOADED T-BOLT; 3.28-3.58	12975-0350
10	4	CLAMP, WORM; 1.31 - 2.25	14990-28
11	4	CLAMP, WORM; 1.56 - 2.50	14990-32
12	1	PLUG, NPT, PLASTIC; -16 (1") NPT	15255-16
13	1	HEAT EXCHANGER, JW, COPPER NICKEL; 6" DIA, CFPSE/7E	15720
14	1	HEAT EXCHANGE, CAC, COPPER NICKEL; 6" DIA, CFPSE/7E	15721
15	2	PLATE, HEAT EXCHANGER MOUNTING; CFPSE/7E	16726
16	2	PLATE, HEAT EXCHANGER MOUNTING; CFPSE/7E	16727
17	1	TAG; ENGINE WEIGHT	16825
18	1	WASHER, FLAT, SMALL; 0.31	20020
19	1	HOSE, FUEL LINE, 5/16ID; 48"L	27003
20	1	SIGHT GLASS, 1/2" NPT;	3277K34
21	1	CLAMP, U-BOLT; 2" OD PIPE	89541K
22	1	HOSE, 1.75 IN ID X 36IN EPDM; CUT TO 4.00 INCHES LONG	A042F053
23	1	HOSE, 1.75 IN ID X 36IN EPDM; CUT TO 5 INCHES LONG	A042F053
24	1	HOSE, 2 INCH ID X 36IN EPDM; CUT TO 5.00 INCHES LONG	A042F054
25	1	HOSE, 90 DEGREE; SWEEP, 2" I.D., 2.25" O.D.	E70739
26	3	SCREW, HH; M10-1.50x25	20310-025
27	4	SCREW, HH; M8-1.25x25	20308-025

<small>This document contains confidential and trade secret information, is the property of Cummins Fire Power LLC and is loaned to the recipient in confidence. The recipient, by accepting and retaining of this document accepts the responsibility of maintaining and protecting this information and not to disclose it to any third party without the prior written consent of Cummins Fire Power LLC. If you are not the intended recipient, you should not disseminate, distribute or copy this document. If you have received this document in error, please notify the system manager. This document is intended for use by the recipient only. All other rights reserved. ©2016 Cummins Fire Power LLC. All rights reserved.</small>						CUMMINS FIRE POWER LLC CORPORATE OFFICE 1400 SUIPERLE ROAD WHITE BEAR LAKE, WI WWW.CUMMINSFIREPOWER.COM		CUSTOM DESIGN AND UPFIT CENTER 875 LAWRENCE DRIVE DEPERE, WISCONSIN	
UNLESS OTHERWISE SPECIFIED ALL DIMENSION TOLERANCES ARE: ANGULAR DIMENSIONS ± 1° THIRD ANGLE PROJECTION				METRIC SURFACES 0.125		DWG UNITS: IN/LB/S SCALE: 0.250 EST WEIGHT: 0.000		DRAWN BY: PRS <b>PRO-ENGINEER</b> SHEET 1 OF 1 DATE: 09SEP2016 INIT ECO: 2016-376 DRAWING NO: A042H722	
A	2018-229	REPLACED E70739 WAS 21379	LOG29	23APR18					
REV	ECO	DESCRIPTION OF REVISION	REV BY	DATE					

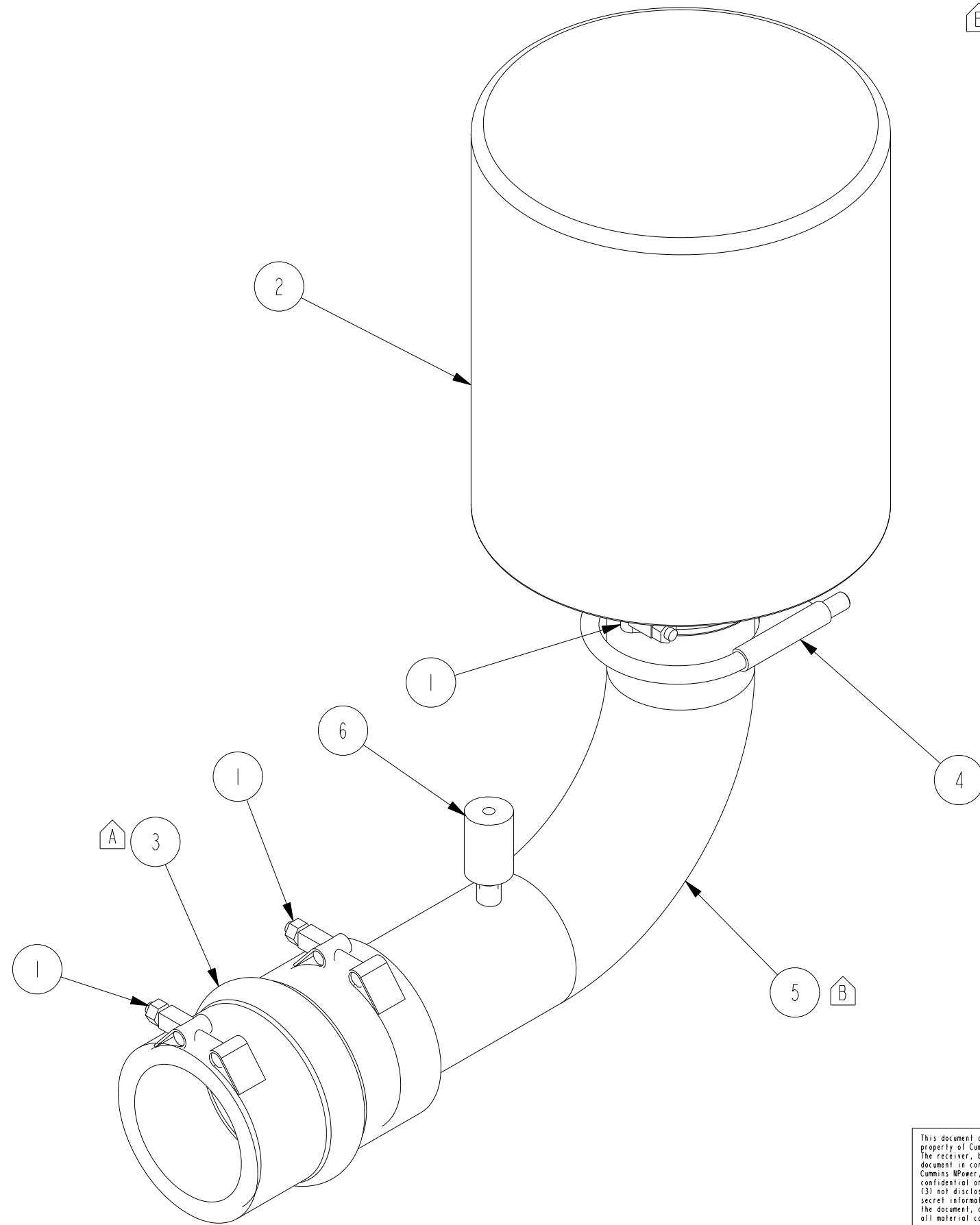

B A

BILL OF MATERIAL			
ITEM	QTY	DESCRIPTION	PART NUMBER
1	3	CLAMP, T-BOLT, 3.28-3.59	13164-0350
2	1	AIR CLEANER, 3" CONNECTION, CF# AH1107 OR EQUAL	15607
3	1	COUPLING, RUBBER, 3", CUMMINS FILTRATION, HOSE	3316606S
4	1	CLAMP, U-BOLT, GUILLOTINE, 3.00"	89545K
5	1	TUBE, AIR INTAKE	A042A663
6	1	RESTRICTION INDICATOR, 1/8" NPT	RAX00-2352

This document contains confidential and trade secret information, is the property of Cummins Fire Power LLC and is given to the receiver in confidence. The receiver, by receiving and retaining of the document accepts the document in confidence and agrees that, except as authorized in writing by Cummins NPower, it will (1) not use the document or any copy thereof or the confidential or trade secret information therein, (2) not copy the document, (3) not disclose to others either the document or the confidential or trade secret information therein, and (4) upon completion of the need to retain the document, or upon demand, return the document, all copies thereof, and all material copied therefrom. COPYRIGHT Cummins Fire Power LLC



CUMMINS FIRE POWER LLC  
CORPORATE OFFICE  
1600 BUERKLE ROAD  
WHITE BEAR LAKE, MN  
WWW.CUMMINSFIREPOWER.COM

CUSTOM DESIGN  
AND UPFIT CENTER  
875 LAWRENCE DRIVE  
DEPERE, WISCONSIN

UNLESS OTHERWISE SPECIFIED ALL DIMENSION TOLERANCES ARE

ANGULAR DIMENSIONS ± 1°	MACHINED SURFACES	IMPERIAL UNITS	METRIC UNITS
THIRD ANGLE PROJECTION	125	MACHINE TOLERANCES .XX ± 0.010 .XXX ± 0.005	MACHINE TOLERANCES .X ± 0.4 .XX ± 0.2
		FORM TOLERANCES .XX ± 0.030 .XXX ± 0.015	FORM TOLERANCES .X ± 0.8 .XX ± 0.4
		FAB TOLERANCES .XX ± 0.060 .XXX ± 0.030	FAB TOLERANCES .X ± 1.5 .XX ± 0.8

ASSEMBLY, AIR CLEANER CFP5E		
DWG UNITS: IN/LB/S	DRAWN BY: PBS <b>PRO-ENGINEER</b>	DATE: 06FEB2014 INIT ECO: 2014-076
SCALE: 0.375	SHEET 1 OF 1	DRAWING NO: A042A396
EST WEIGHT: 42238.628		

B	2014-786	UPDATED A042A663 WAS 15417	MRH	11NOV2014
A	2014-360	OMIT 89833K, ADD 3316606S	MRH	22MAY2014
REV	ECO	DESCRIPTION OF REVISION	REV BY	DATE

BILL OF MATERIAL			
ITEM	QTY	DESCRIPTION	PART NUMBER
1	1	HOSE, HEATER, 3/4" ID x 15.00"	A042F073
2	1	HOSE, HEATER, 3/4" ID x 14.00"	A042F073
3	2	SPACER, 0.5 OD X 0.38 ID X 0.50 LG	9618
4	1	ELB, 90 DEG, -12 NPT X -12 FMNPT	12195-12-12
5	1	ELB, 45 DEG, -8 NPT X -8 FMNPT	12532-8-8
6	2	FTG, STR, -12 BEAD X -12 NPT	12545-12-12
7	1	FTG, STR, -12 BEAD X -8 NPT	12545-12-8
8	1	ELB, 90 DEG, -12 BEAD X -12 NPT	12547-12-12
9	4	CLAMP, WORM, .56-1.06	14990-10
10	2	WASHER, FLAT, M8	20020-M8
11	1	BRACKET, COOLANT HEATER MOUNTING, CFP5E/7E	24233
12	1	HEATER, COOLANT, 1500W, 120/240VAC	24238
13	1	ADAPTER, M18 TO 1/2 NPT	A042J938
14	2	SCREW, HH, M8-1.25x60	20308-060

REV	REL NO	REVISION	DWN	CKD	APVD	DATE
-	2016-668	RELEASED TO PRODUCTION	HE392	NE627	NE627	16NOV16
A	2017-096	DELETE 12181-M18-8, ADD A042J938	HE392	NE627	NE627	15FEB17
B	2019-188	REPLACED 14990-12 W/ 14990-10	NO134	MS707	MS707	19APR19

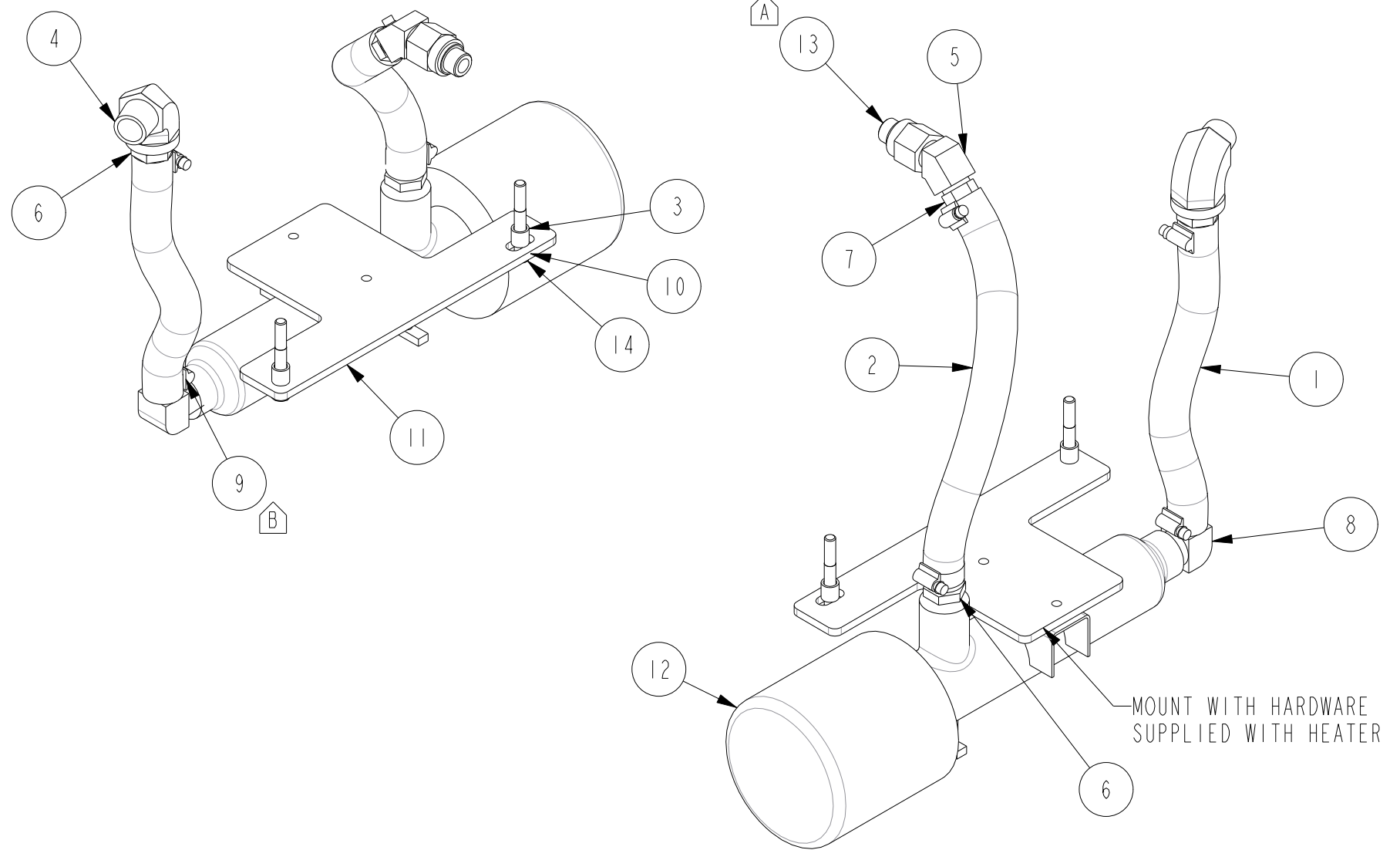

- NOTES:
- ATTACH HOSE TO HEATER WITH OUT RADIAL TWIST
  - APPLY THREAD SEALANT ON ALL NPT THREADS

DIMENSIONS ARE IN: INCHES [ ] ARE IN: .	<b>DO NOT SCALE PRINT</b>	CMI DATA CLASSIFICATION Cummins Confidential		Cummins Inc.		
DRAWING TOLERANCES UNLESS OTHERWISE SPECIFIED	SCALE 0.250	DWN HE392		ITEM NAME		
X: ± 1 IN OR 4 mm X.X: ± .1 IN OR 0.7 mm X.XX: ± .030 IN OR 0.25 mm X.XXX: ± .010 IN OR 0.075 mm ANGULAR TOLERANCE: ± 1°		CKD NE627		ASSEMBLY, COOLANT HEATER CFP5E		
THIS DOCUMENT (AND THE INFORMATION SHOWN THEREON) IS CONFIDENTIAL AND PROPRIETARY AND SHALL NOT BE DISCLOSED TO OTHERS IN HARD COPY OR ELECTRONIC FORM, REPRODUCED BY ANY MEANS, OR USED FOR ANY PURPOSE WITHOUT WRITTEN CONSENT OF CUMMINS INC.		APVD NE627		MUST CONFORM TO CES 10903	DWG SIZE <b>B</b>	CAD SHEET 1 OF 1
		DATE 16NOV2016	FOR INTERPRETATION OF DIMENSIONING AND TOLERANCING, SEE ASME Y14.5-2009			REV B

BILL OF MATERIAL

ITEM	QTY	DESCRIPTION	PART NUMBER
1	4	SCREW,HH, 0.38-16x1.00	20238-100
2	1	FILTER HEAD, CUMMINS	142784-S
3	1	FILTER, FUEL	FS1212

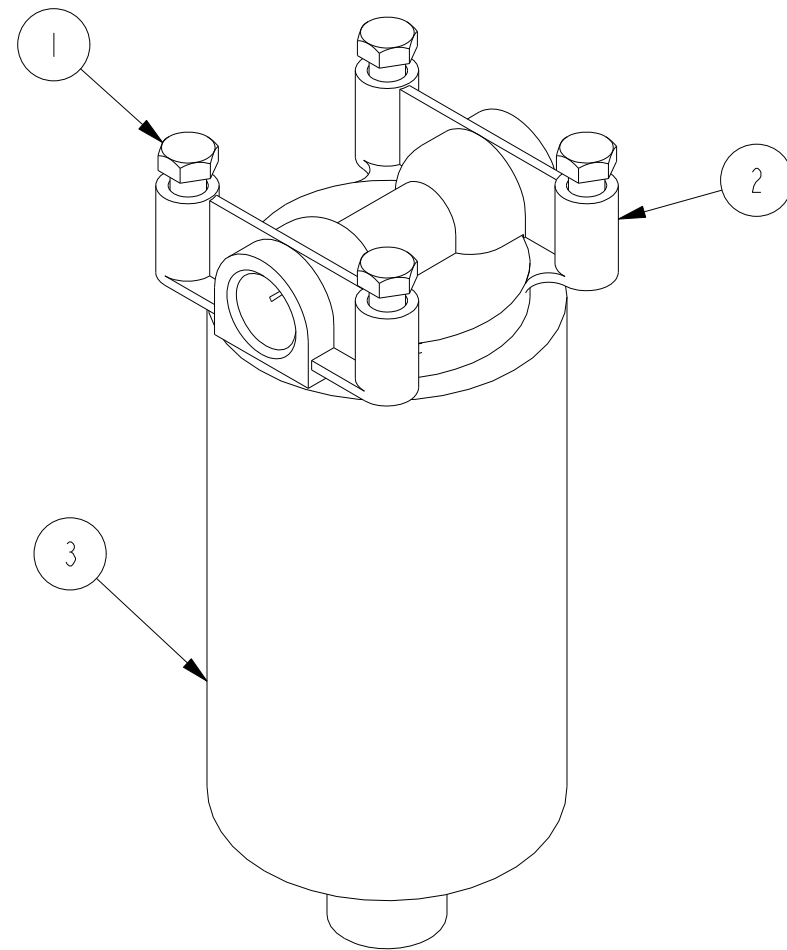

This document contains confidential and trade secret information, is the property of Cummins Fire Power LLC and is given to the receiver in confidence. The receiver, by receiving and retaining of the document accepts the document in confidence and agrees that, except as authorized in writing by Cummins NPower, it will (1) not use the document or any copy thereof or the confidential or trade secret information therein, (2) not copy the document, (3) not disclose to others either the document or the confidential or trade secret information therein, and (4) upon completion of the need to retain the document, or upon demand, return the document, all copies thereof, and all material copied therefrom. COPYRIGHT Cummins Fire Power LLC



CUMMINS FIRE POWER LLC  
CORPORATE OFFICE  
1600 BUERKLE ROAD  
WHITE BEAR LAKE, MN  
WWW.CUMMINSFIREPOWER.COM

CUSTOM DESIGN  
AND UPFIT CENTER  
875 LAWRENCE DRIVE  
DEPERE, WISCONSIN

ASSEMBLY, FUEL PREFILTER

UNLESS OTHERWISE SPECIFIED ALL DIMENSION TOLERANCES ARE

ANGULAR DIMENSIONS ± 1°	MACHINED SURFACES	IMPERIAL UNITS	METRIC UNITS
THIRD ANGLE PROJECTION	125	MACHINE TOLERANCES .XX ± 0.010 .XXX ± 0.005	MACHINE TOLERANCES .X ± 0.4 .XX ± 0.2
		FORM TOLERANCES .XX ± 0.030 .XXX ± 0.015	FORM TOLERANCES .X ± 0.8 .XX ± 0.4
		FAB TOLERANCES .XX ± 0.060 .XXX ± 0.030	FAB TOLERANCES .X ± 1.5 .XX ± 0.8

DWG UNITS: IN/LB/S	DRAWN BY: PBS <b>PRO-ENGINEER</b>	DATE: 08SEP2016 INIT ECO: 2016-376
SCALE: 0.500	SHEET 1 OF 1	DRAWING NO: A042H709
EST WEIGHT: 0.000		

REV	ECO	DESCRIPTION OF REVISION	REV BY	DATE

BILL OF MATERIAL			
ITEM	QTY	DESCRIPTION	PART NUMBER
A 1	1	PLUG, COMMON RAIL FUEL CONNECTION, M20-1.5	13998
2	1	ADAPTER, "Y"-COMMON RAIL FUEL CONNECTION, M18-1.5 X M18-1.5	14198
3	1	VALVE, PRESSURE RELIEF,	3947799
A 4	1	CAP SCREW, M12 X 1.50 X 16MM LONG	91180A743

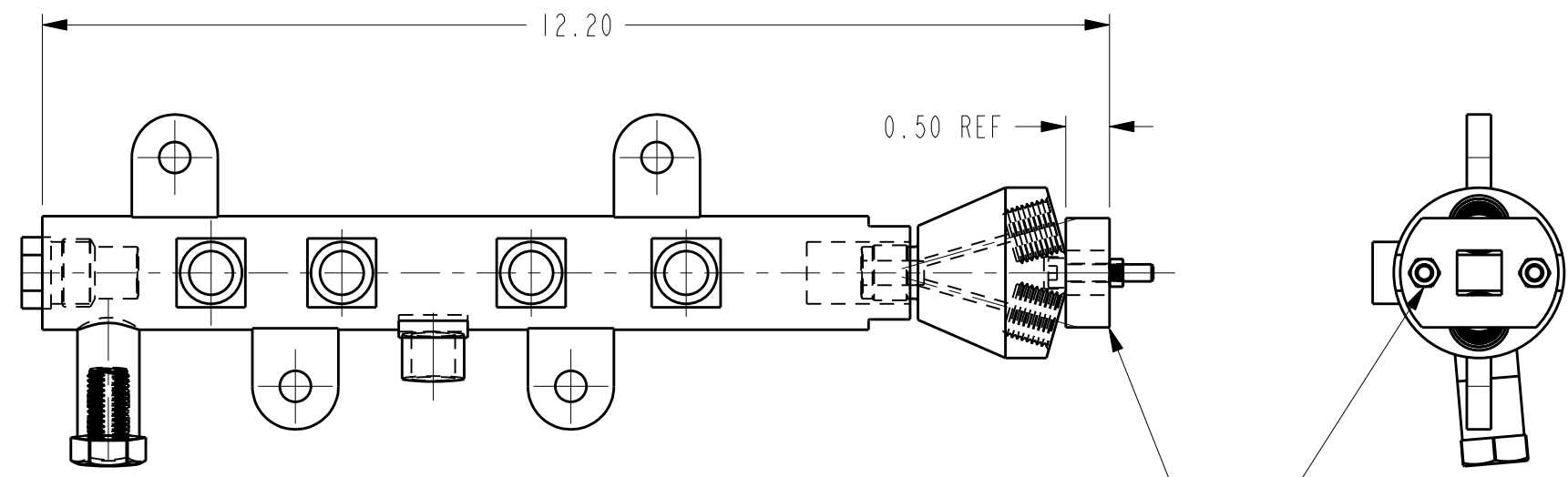

USE PN: 14201  
TORQUE ADAPTER "Y" DETAIL: 1  
TO 75 FT/LB

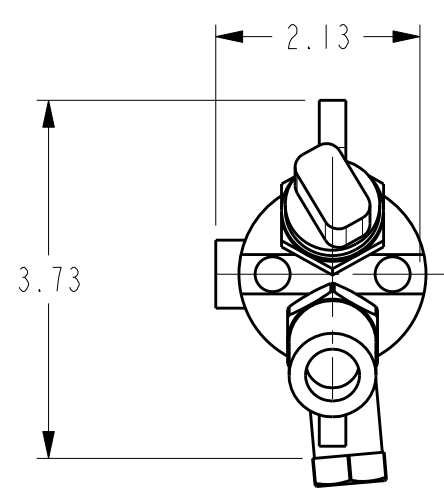
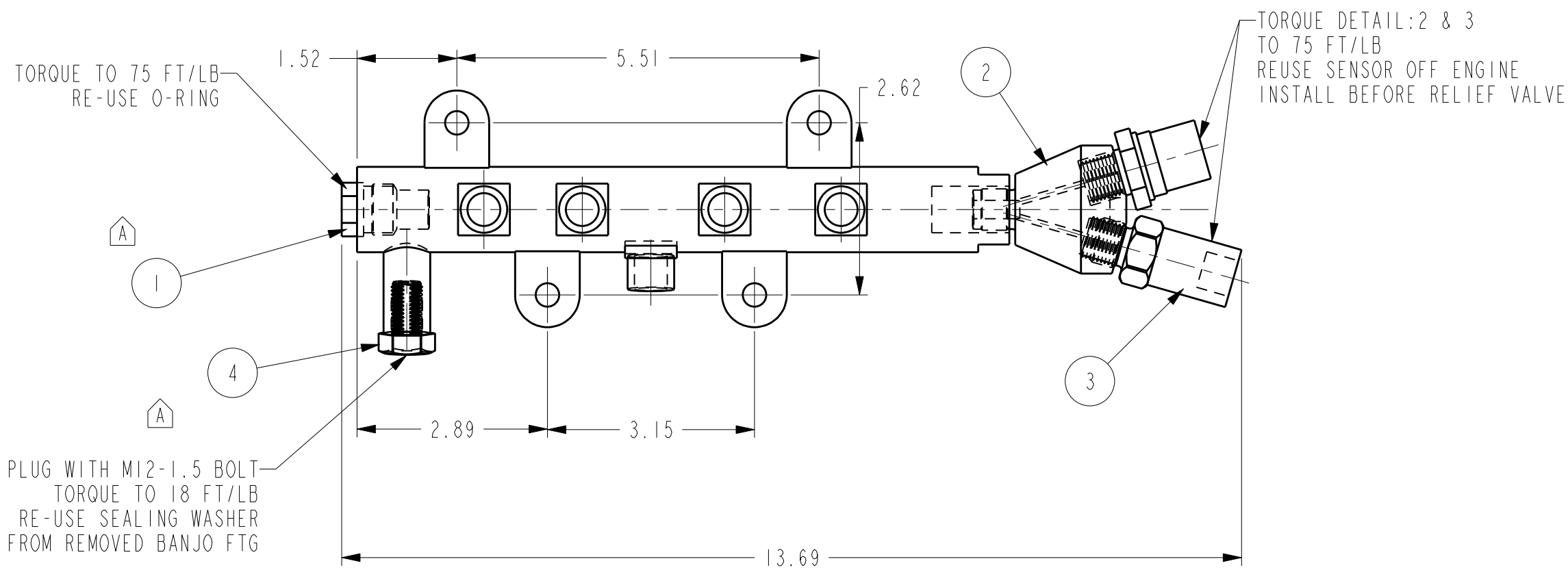
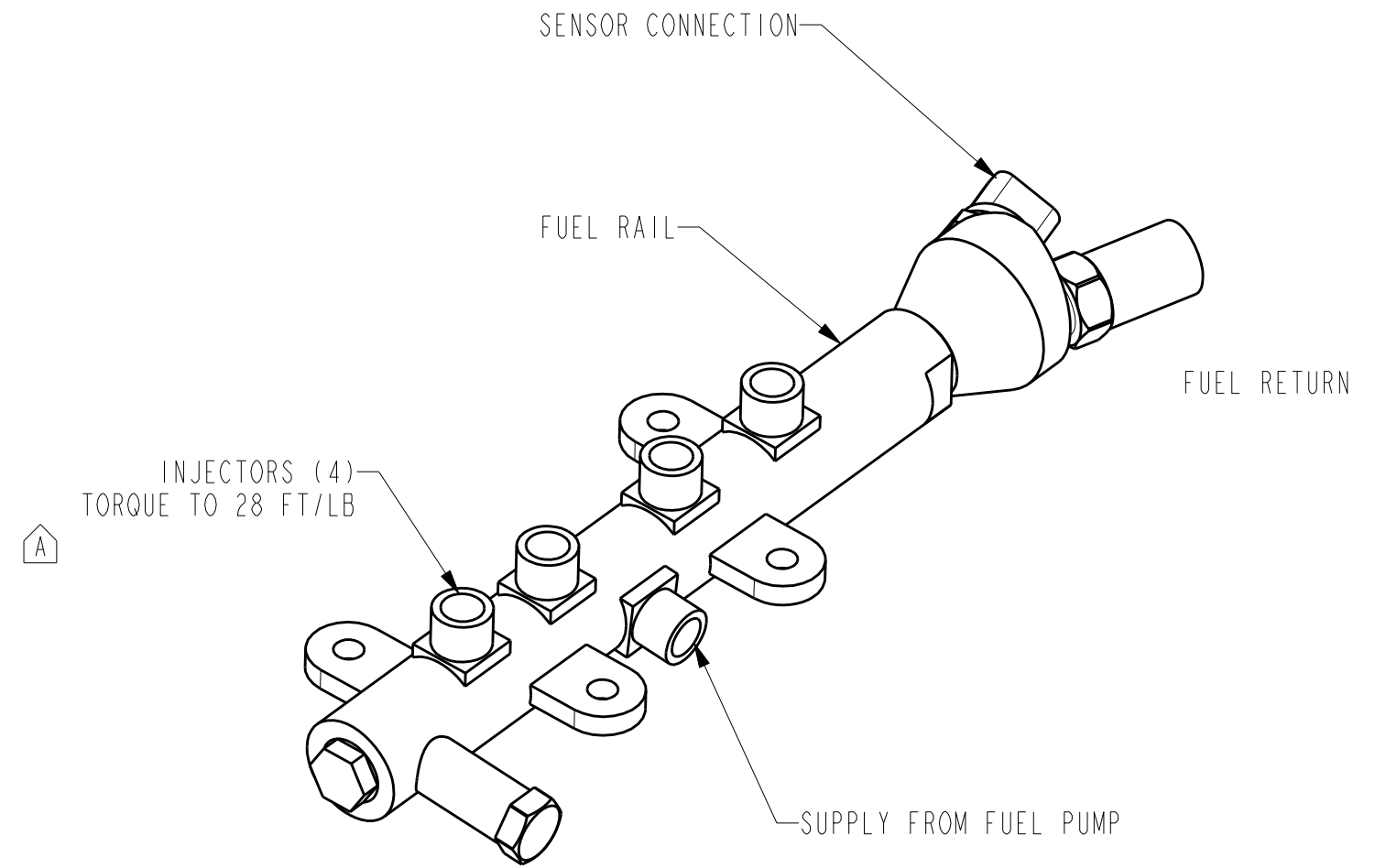

This document contains confidential and trade secret information, is the property of Cummins Fire Power LLC and is given to the receiver in confidence. The receiver, by receiving and retaining of the document accepts the document in confidence and agrees that, except as authorized in writing by Cummins Fire Power, it will not use the document or any copy thereof or the confidential or trade secret information therein. It will not copy the document, disclose to others either the document or the confidential or trade secret information therein, and it will upon completion of the need to retain the document, or upon demand, return the document, all copies thereof, and all material copied therefrom. ©COPYRIGHT Cummins Fire Power LLC

**Cummins Fire Power**  
CORPORATE OFFICE  
1600 BUERKLE ROAD  
WHITE BEAR LAKE, MN  
WWW.CUMMINSFIREPOWER.COM

CUSTOM DESIGN  
AND UFIT CENTER  
875 LAWRENCE DRIVE  
DEPERE, WISCONSIN

ASSEMBLY, FUEL RAIL MODIFICATION  
FIREPUMP, CFP5E

UNLESS OTHERWISE SPECIFIED ALL DIMENSION TOLERANCES ARE

ANGULAR DIMENSIONS	± 1°	IMPERIAL UNITS	METRIC UNITS
THIRD ANGLE PROJECTION		MACHINE TOLERANCES FRACTIONS ± 1/16 - 3/32 DECIMALS ± 0.005 - 0.015 FAB TOLERANCES ± 0.010	MACHINE TOLERANCES FRACTIONS ± 1/16 - 3/32 DECIMALS ± 0.005 - 0.015 FAB TOLERANCES ± 0.010

DWG UNITS: IN/LB/S	DRAWN BY: MAC <b>PRO-ENGINEER</b>	DATE: 01-07-2009
SCALE: 0.500	SHEET 1 OF 1	INIT ECO:
EST WEIGHT: 42238.628		DRAWING NO: 14202

REV	ECO	DESCRIPTION OF REVISION	REV BY	DATE
A	2010-127	ADDED PLUG & BOLT. ADDED TORQUE	DAN	23-MAR-10



BILL OF MATERIAL			
ITEM	QTY	DESCRIPTION	PART NUMBER
1	1	HARNESS,WIRE, ECM A/B, CFP5E, FPDP GEN 2	A042H289
2	1	HARNESS,WIRE,PWR/INTERFACE, CFP5E, FPDP GEN 2	A042H290
3	1	HARNESS,WIRE,SENSOR & ACTUATOR, CFP5E, FPDP GEN 2	A042J131
4	1	SENSOR, MAG PICK UP, #5MT2005	9569
5	1	SWITCH, PROXIMITY, 2M CABLE, 12-24V	12865
6	1	WASHER, PRESSURE SEALING WASHER, -	13769
7	1	CABLES, BATTERY, CFP5E, 7E, 9E, 11E	24234
8	1	CONNECTOR, QUICK DISCONNECT	3377244
9	2	SENSOR,PRESSURE	4921499

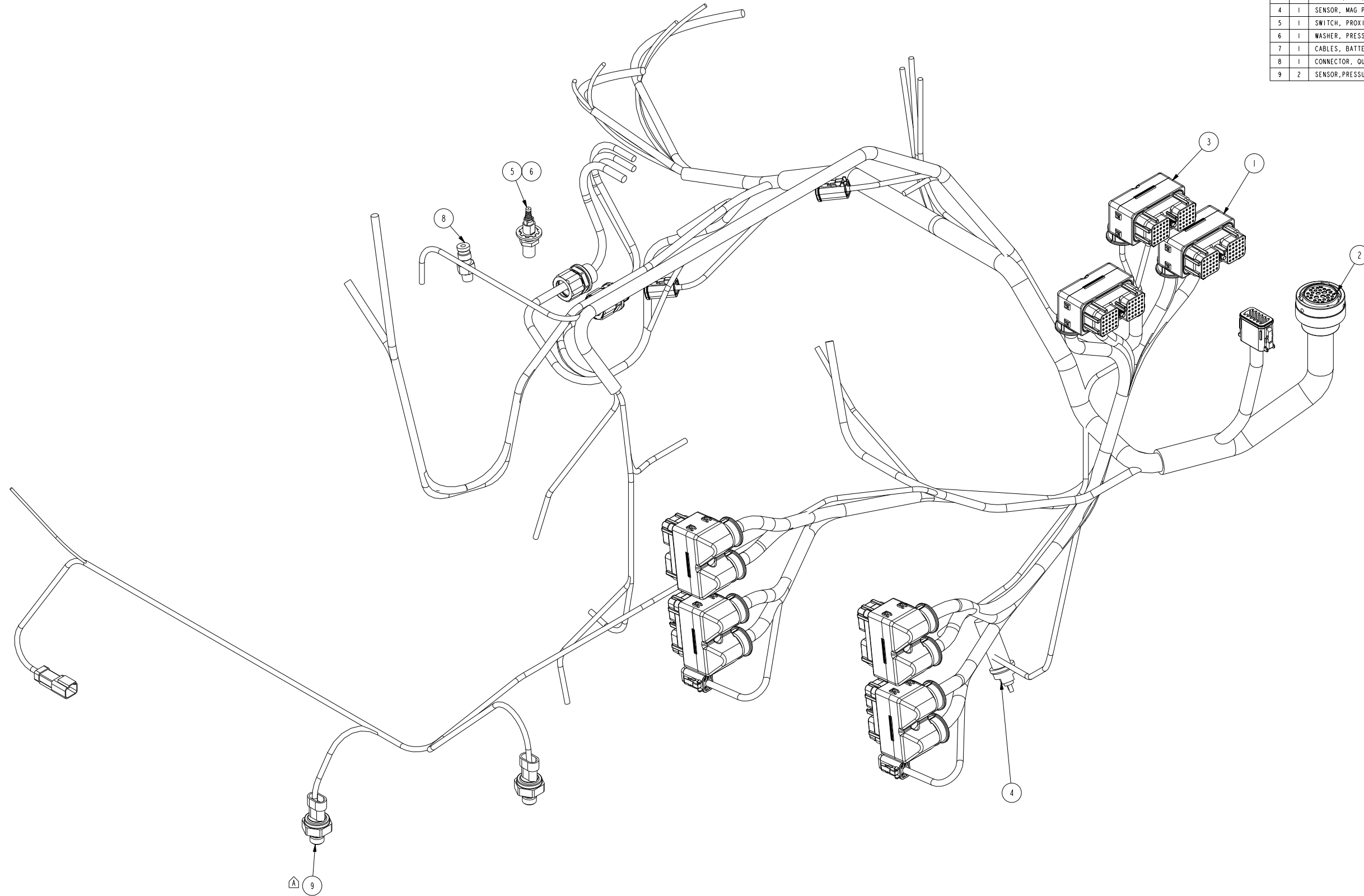

- NOTES:
1. USE TOOL 13826 TO SET PROXIMITY SENSOR (12865) HEIGHT
  2. USE SOCKET THAT IS MODIFIED TO ACCOMMODATE SENSOR WIRES
  3. RE-USE VALVE COVER GASKET AND HARDWARE

CUMMINS CONFIDENTIAL						CUMMINS NPOWER LLC CORPORATE OFFICE 1600 BIERLIE ROAD WHITE BEAR LAKE, WI WWW.CUMMINSNPOWER.COM		CUSTOM DESIGN AND UPFIT CENTER 875 LAWRENCE DRIVE DEPERE, WISCONSIN	
UNLESS OTHERWISE SPECIFIED ALL DIMENSION TOLERANCES ARE ANGULAR DIMENSIONS ± 1°				MACHINED SURFACES FINISH: 125		IMPERIAL UNITS: IN/LB/S		DWG UNITS: IN/LB/S	
THIS DOCUMENT CONTAINS CONFIDENTIAL AND TRADE SECRET INFORMATION. IT IS THE PROPERTY OF CUMMINS NPOWER LLC AND IS LOANED TO THE RECIPIENT FOR USE ONLY. THE RECIPIENT SHALL NOT REPRODUCE, DISSEMINATE, OR USE THIS INFORMATION FOR ANY OTHER PURPOSES WITHOUT THE WRITTEN PERMISSION OF CUMMINS NPOWER LLC.				ASSEMBLY, SENSORS & HARNESSING CFP5E		DRAWN BY: RMB		DATE: 20JAN2017	
REV A 2017-137 ADD 4921499				REV BY: PBS		DATE: 07MAR2017		SHEET 1 OF 2	
DESCRIPTION OF REVISION				EST WEIGHT: 3.182		SCALE: 0.500		DRAWING NO: A042H288	

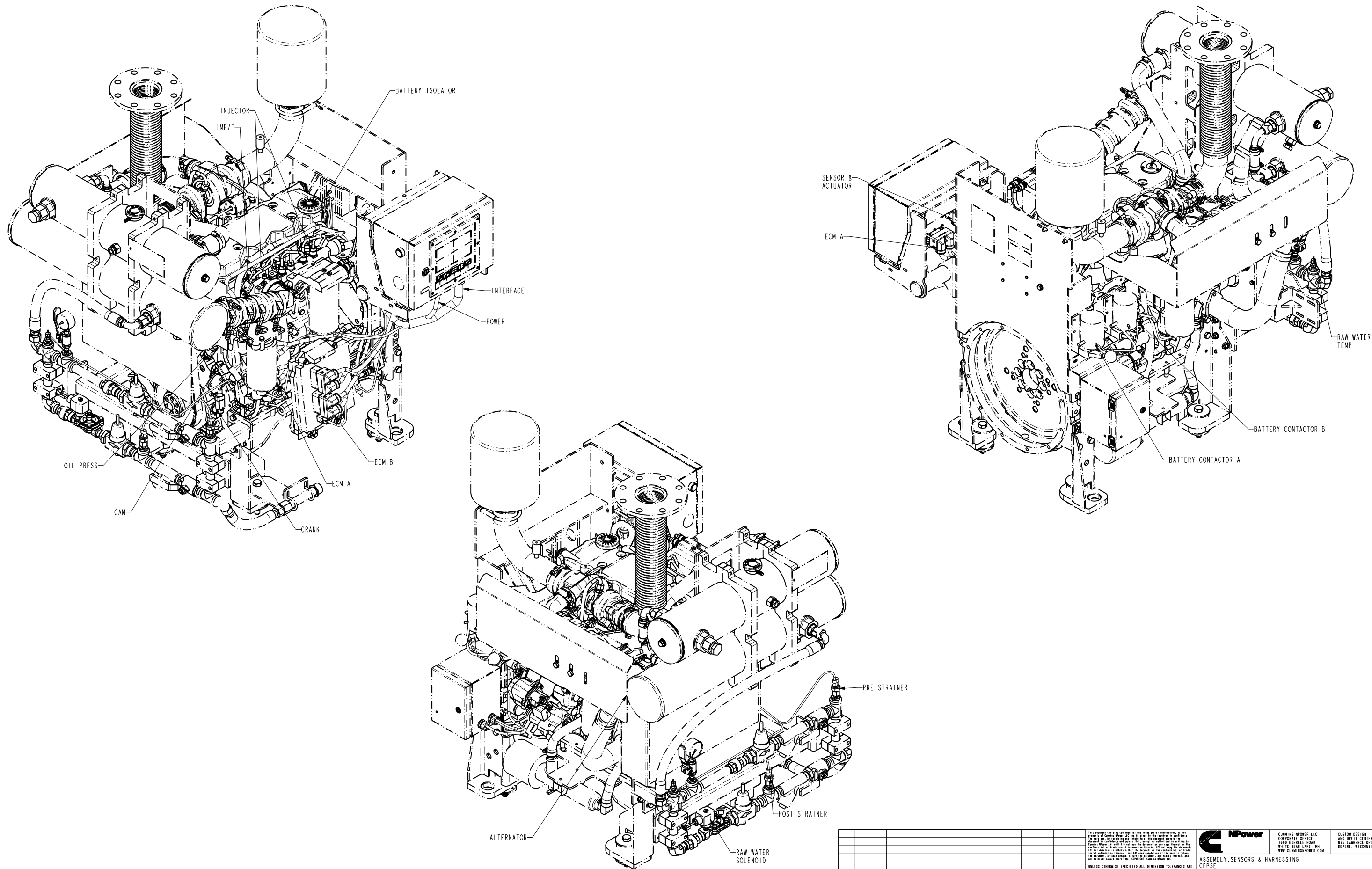

<small>This document contains confidential and trade secret information, is the property of Cummins Power LLC, and is loaned to the customer in confidence. The customer, by reviewing and accepting this document, agrees to maintain the confidentiality of trade secret information therein. If not clear, the customer will not disclose, in any way, the contents of this document or trade secret information contained herein, nor will the customer, its agents, representatives, or contractors, disclose the contents of this document, or any portion, to any third party, without the prior written consent of Cummins Power LLC. If you are not an authorized recipient, you should not use, copy, or disseminate this information. ©2017 Cummins Power LLC</small>						<small>CUMMINS NPOWER LLC CORPORATE OFFICE 1600 BIERLEY ROAD WHITE BEAR LAKE, WI WWW.CUMMINSPOWER.COM</small>		<small>CUSTOM DESIGN AND SUPPORT CENTER 875 LAWRENCE DRIVE DEPERE, WISCONSIN</small>	
<small>UNLESS OTHERWISE SPECIFIED ALL DIMENSION TOLERANCES ARE</small>									
				<small>ANGULAR DIMENSIONS ± 1°</small>		<small>MACHINED SURFACES</small>		<small>IMPERIAL METRIC</small>	
				<small>THIRD ANGLE PROJECTION</small>		<small>125</small>		<small>DWG UNITS: IN/LB/S</small>	
				<small>SCALE: 0.500</small>		<small>PRO-ENGINEER</small>		<small>DATE: 20JAN2017</small>	
<small>REV A 2017-137 SEE SHEET 1 FOR LATEST REVISION DETAILS</small>				<small>REV BY ECO</small>		<small>DATE 07MAR2017</small>		<small>SHEET 2 OF 2</small>	
<small>DESCRIPTION OF REVISION</small>				<small>REV BY</small>		<small>DATE</small>		<small>DRAWING NO: A042H288</small>	
						<small>EST WEIGHT: 3.182</small>			

BILL OF MATERIAL			
ITEM	QTY	DESCRIPTION	PART NUMBER
1	1	BRACKET, ECM MOUNTING; CFP5E & CFP7E	13310
2	1	STAND OFF, ECM, 103mm BOLT PATTERN	14392
3	1	GROUND STRAP, 1/4" WIDE; 12" HOLE CENTERS	15197
4	3	ISOLATOR,VIBRATION	3955219
5	3	ISOLATOR,VIBRATION	3955220
6	1	MODULE,ELECTRONIC CONTROL	4354531
7	1	BRACKET; ETR CNT MODULE	5309216

REV	REL NO	REVISION	DWN	CKD	APVD	DATE
E	2014-615	ADDED 15197	MS707	-	-	29AUG14
7	2019-464	REPLACED 12726 W/ 4354531; REMOVED 20020-M8,20308-035,20308-040,20312-025	NO134	MS707	MS707	24SEP19
8	2019-475	UPDATED CFP7E ORIENTATION AND NOTES	OY256	MS707	MS707	26NOV19

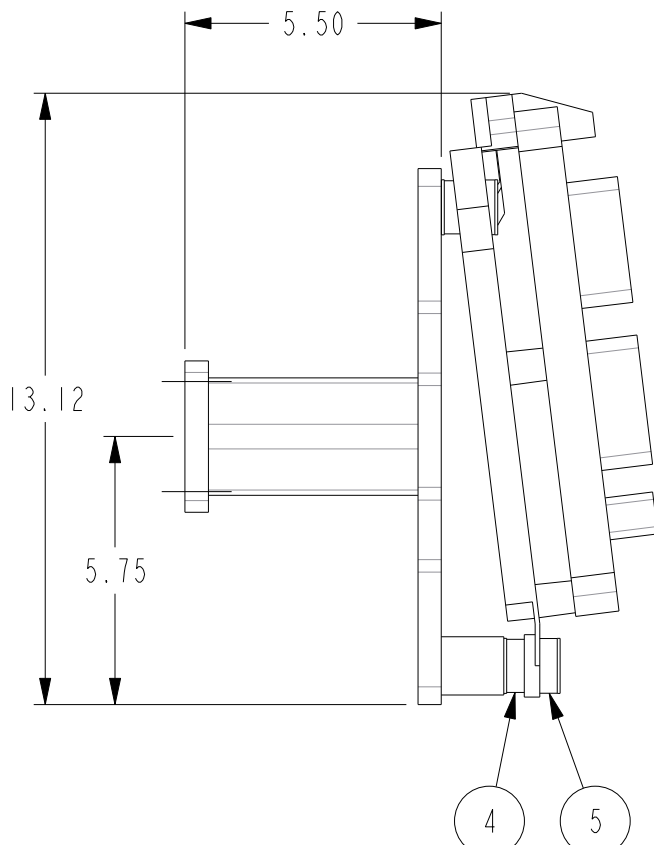

CFP5E ORIENTATION SHOWN 8

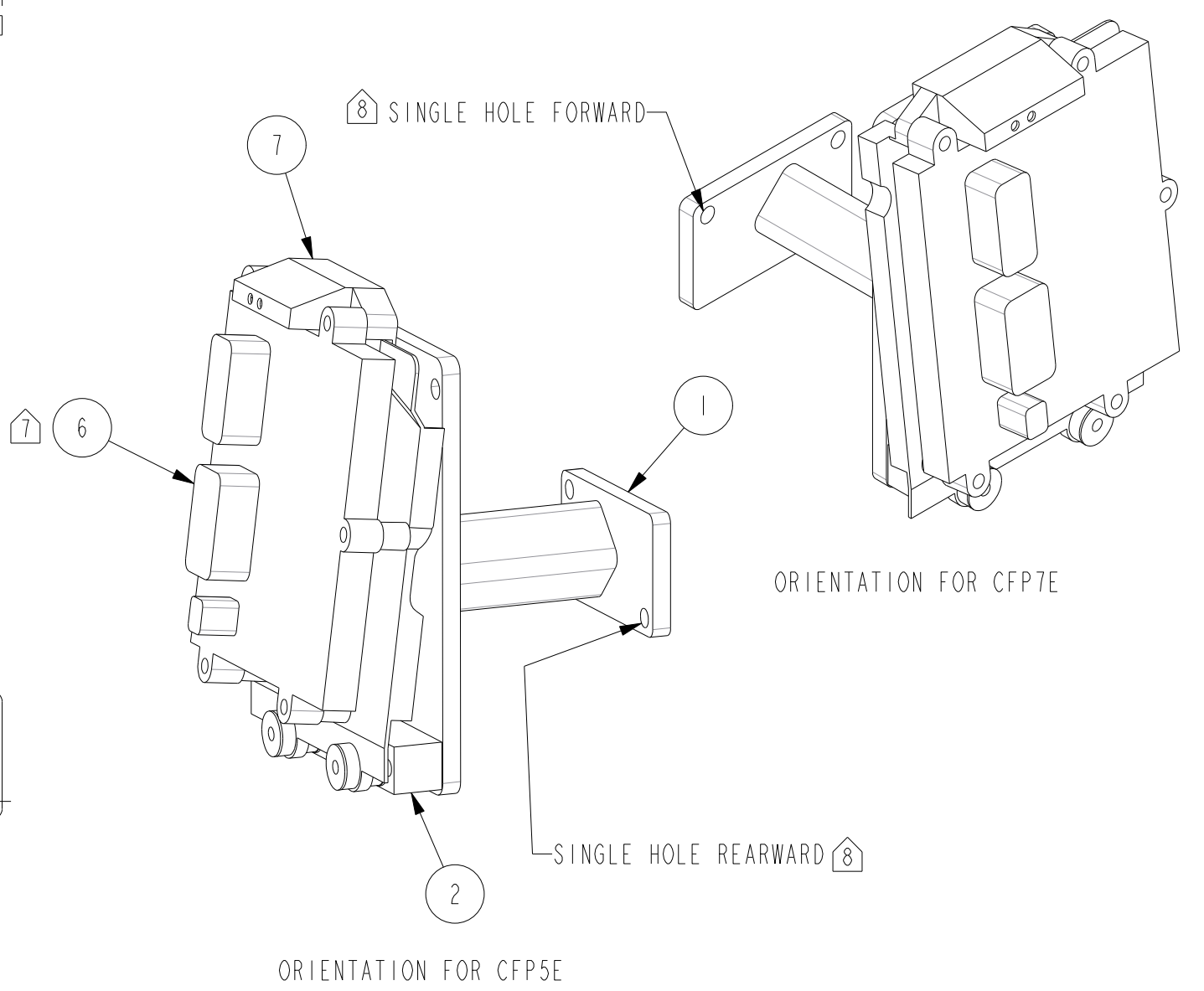
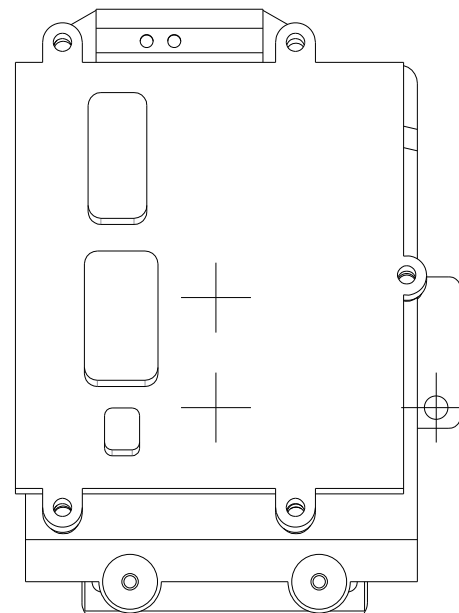
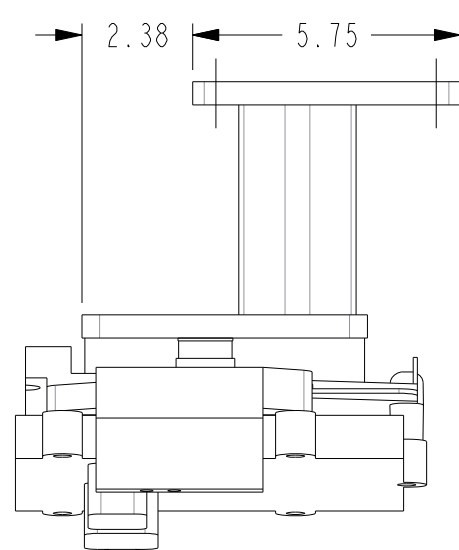

DIMENSIONS ARE IN: INCHES [ ] ARE IN: .	DO NOT SCALE PRINT	CMI DATA CLASSIFICATION Cummins Confidential		Cummins Inc.			
	SCALE 0.250	DWN MAC		ITEM NAME			
DRAWING TOLERANCES UNLESS OTHERWISE SPECIFIED X: ± .1 IN OR 4 mm X.X: ± .01 IN OR 0.7 mm X.XX: ± .030 IN OR 0.25 mm X.XXX: ± .010 IN OR 0.075 mm ANGULAR TOLERANCE: ± 1°		CKD - APVD - DATE 09DEC2008	MUST CONFORM TO CES 10903	DWG SIZE <b>B</b>	CAD SHEET 1 OF 1	ITEM NUMBER 13309	REV 8
THIS DOCUMENT (AND THE INFORMATION SHOWN THEREON) IS CONFIDENTIAL AND PROPRIETARY AND SHALL NOT BE DISCLOSED TO OTHERS IN HARD COPY OR ELECTRONIC FORM, REPRODUCED BY ANY MEANS, OR USED FOR ANY PURPOSE WITHOUT WRITTEN CONSENT OF CUMMINS INC.		FOR INTERPRETATION OF DIMENSIONING AND TOLERANCING, SEE ASME Y14.5-2009		ASSEMBLY, ECM & MOUNTING CFP5E & CFP7E			

BILL OF MATERIAL

ITEM	QTY	DESCRIPTION	PART NUMBER
1	1	MOUNT, OPERATOR STATION, CFP CONTROL PANEL	22318
2	2	ISOLATOR, PLATE MOUNT, 3 LB (YELLOW MARK)	15400
3	2	ISOLATOR, PLATE MOUNT, 6 LB (RED MARK)	15412
4	12	RIVET, ALUMINUM, STEEL SHANK, 0.156 DIA, 0.25-0.38 GRIP	15414
5	2	FENDER WASHER, 0.281 X 1.25	15421
6	4	SCREW, SELF LOCKING, 0.25-20 X 1.00, PH OR BH	15422

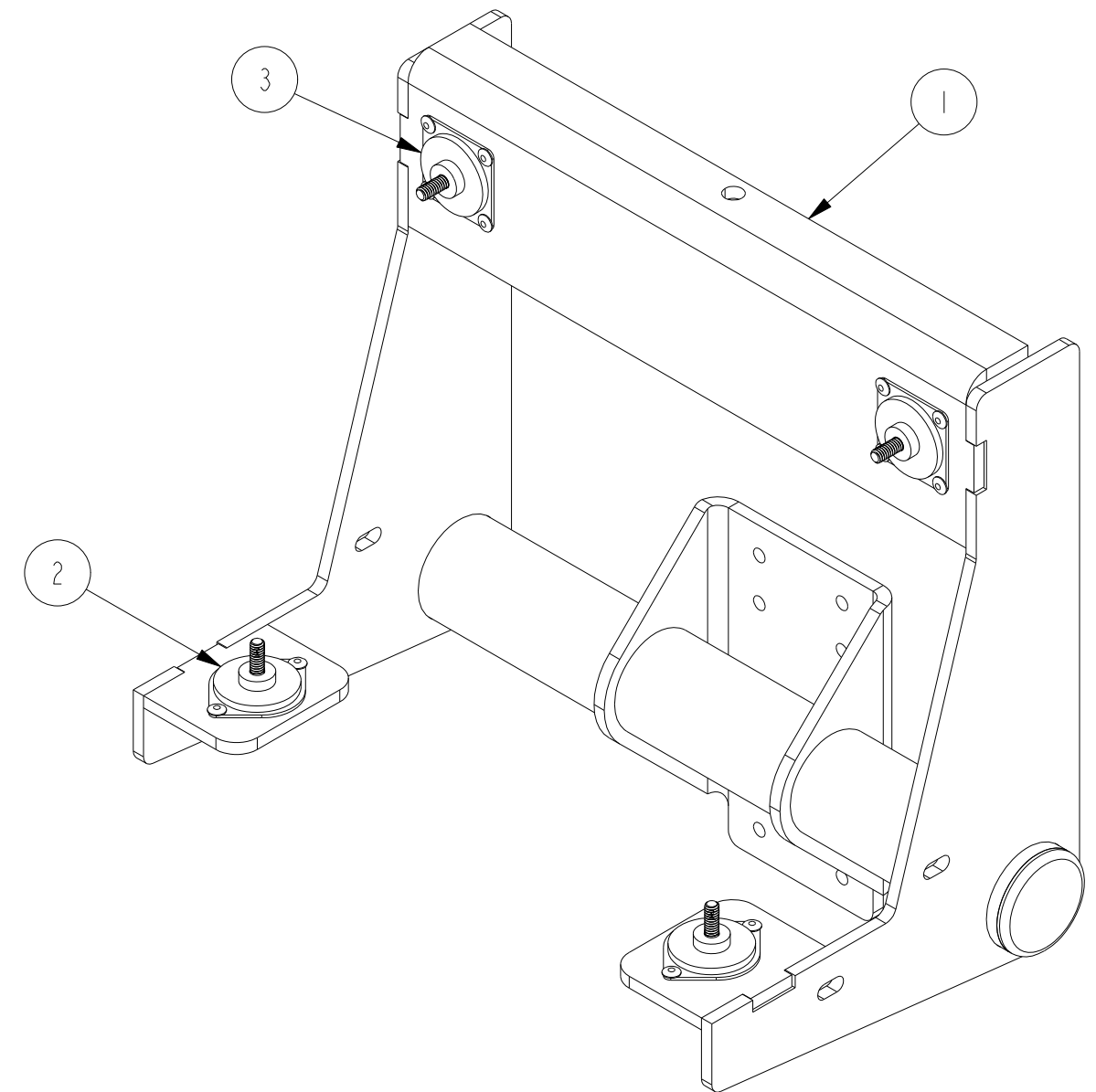
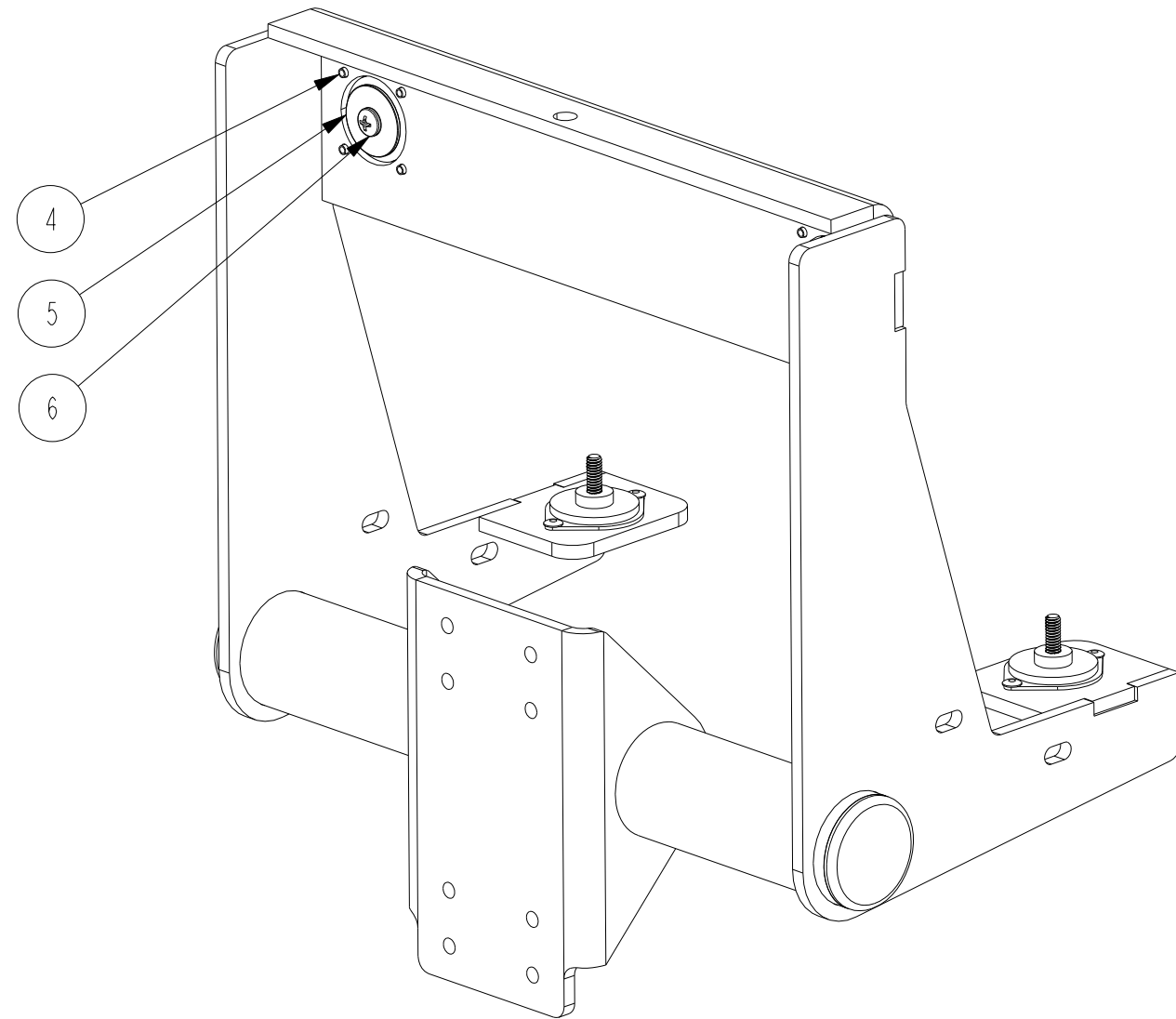

This document contains confidential and trade secret information, is the property of Cummins Fire Power LLC and is given to the receiver in confidence. The receiver, by receiving and retaining of the document accepts the document in confidence and agrees that, except as authorized in writing by Cummins NPower, it will (1) not use the document or any copy thereof or the confidential or trade secret information therein, (2) not copy the document, (3) not disclose to others either the document or the confidential or trade secret information therein, and (4) upon completion of the need to retain the document, or upon demand, return the document, all copies thereof, and all material copied therefrom. COPYRIGHT Cummins Fire Power LLC



CUMMINS FIRE POWER LLC  
CORPORATE OFFICE  
1600 BUERKLE ROAD  
WHITE BEAR LAKE, MN  
WWW.CUMMINSFIREPOWER.COM

CUSTOM DESIGN  
AND UPFIT CENTER  
875 LAWRENCE DRIVE  
DEPERE, WISCONSIN

UNLESS OTHERWISE SPECIFIED ALL DIMENSION TOLERANCES ARE

ANGULAR DIMENSIONS ± 1°	MACHINED SURFACES	IMPERIAL UNITS	METRIC UNITS
THIRD ANGLE PROJECTION	125	MACHINE TOLERANCES .XX ± 0.010 .XXX ± 0.005	MACHINE TOLERANCES .X ± 0.4 .XX ± 0.2
		FORM TOLERANCES .XX ± 0.030 .XXX ± 0.015	FORM TOLERANCES .X ± 0.8 .XX ± 0.4
		FAB TOLERANCES .XX ± 0.060 .XXX ± 0.030	FAB TOLERANCES .X ± 1.5 .XX ± 0.8

ASSEMBLY, CONTROL PANEL MOUNTING  
CFP POWER UNITS

DWG UNITS: IN/LB/S	DRAWN BY: S DUBICK <b>PRO-ENGINEER</b>	DATE: 26-SEP-12 INIT ECO: 2012-392
SCALE: 0.333	SHEET 1 OF 1	DRAWING NO: 21249
EST WEIGHT: 16.439		

REV	ECO	DESCRIPTION OF REVISION	REV BY	DATE

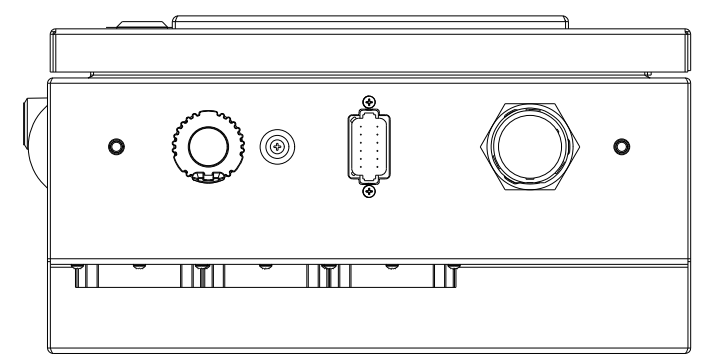
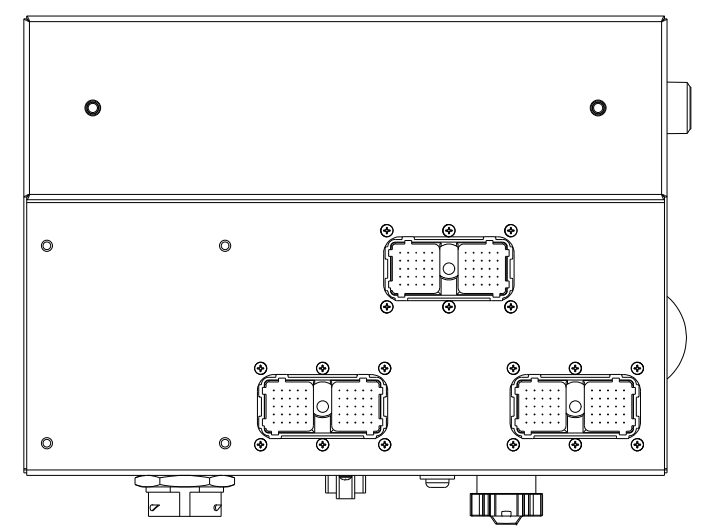
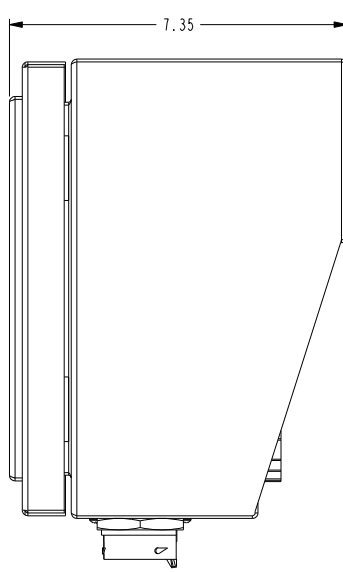
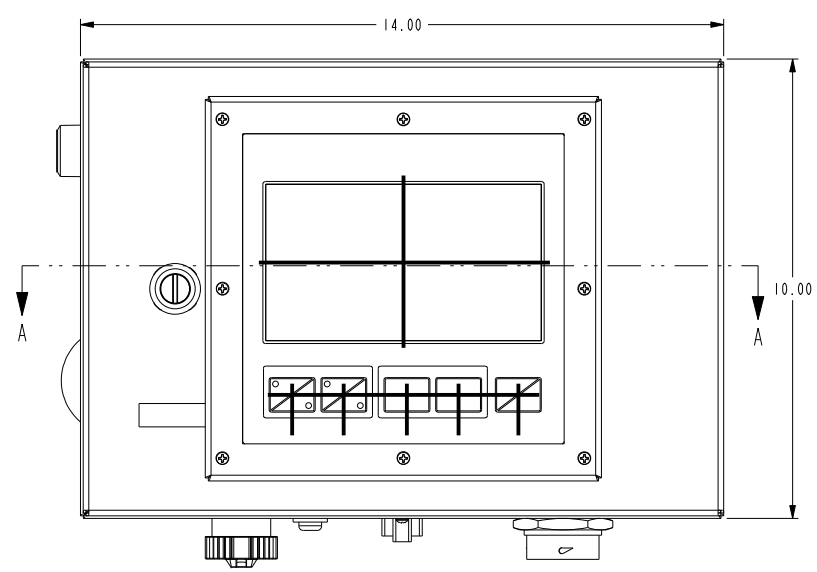
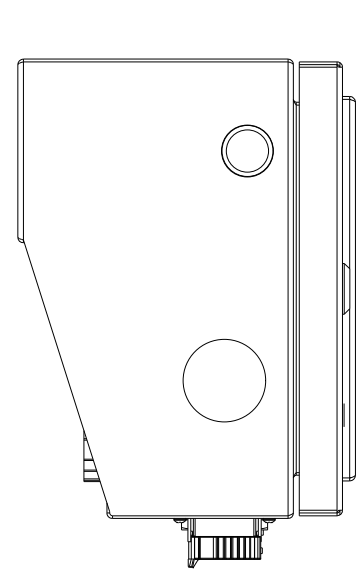
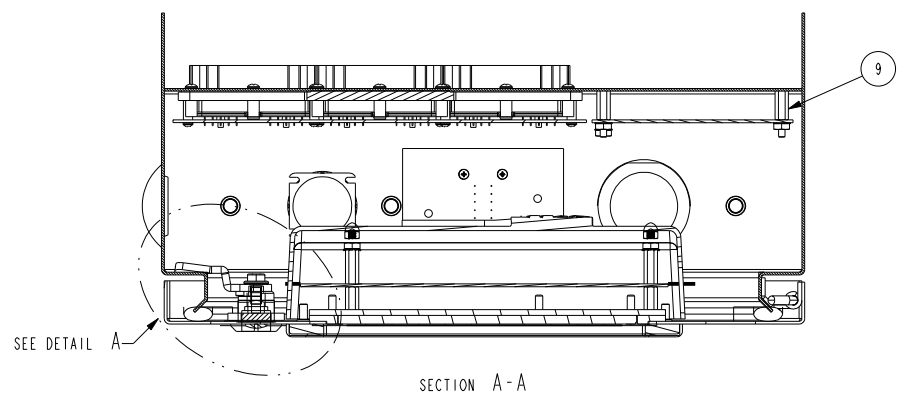
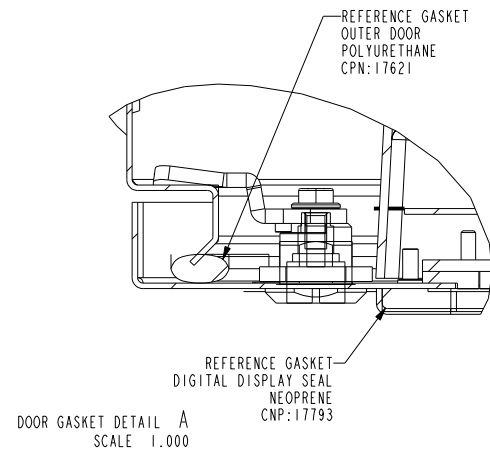

BILL OF MATERIAL			
ITEM	QTY	DESCRIPTION	PART NUMBER
1	1	POWER MODULE ECM , DIGITAL PANEL, ELECTRONIC	15155
2	1	ASSY, WIRING, DIGITAL PANEL, ENGINE STOP SWITCH	15160
3	1	DIAGNOSTICS, DIGITAL PANEL, RECEPTACLE AND CABLE	A042G193
4	1	ASSY,BULKHEAD WIRING, DIGITAL PANEL, BULKHEAD TO POWER PCB	A042G197
5	1	CABLE, DIGITAL PANEL, POWER PCB TO DISPLAY PCB	A042G198
6	1	SWITCH PCB, DIGITAL PANEL, MODULE, ECM	A042G207
7	1	CABINET, CONTROL PANEL	A042H232
8	1	BEZEL, FORMED, STEEL, CONTROL PANEL	15165
9	9	STANDOFF HEX M/F, 8-32, BRASS .63"L	15579
10	6	STANDOFF HEX M/F, 8-32, BRASS .75"L	15580
11	14	NUT, 8-32, W/TOOTH WASHER, ZNC -PLTD	15582
12	1	PLUG, LIQUID TIGHT, HEYCO, 3B37	15645
13	4	NUT, ACORN,SELF-LOCKING, 8-32, 18-8 STNL STL	17149
14	2	STANDOFF HEX M/F, 8-32, BRASS 1.25"L	17205
15	1	BEZEL, GASKET 1/4" x 3/4"	17793
16	1	TIE, WIRE, 4", NATURAL	3M101M-ND
17	1	SCREW, 1/4-20 STAINLESS STEEL	91772A537
18	1	WASHER, 1/4" STAINLESS STEEL	93852A102
19	8	SCREW, 6-32, 1/2" LONG , STAINLESS STEEL, BLACK OXIDE FINISH	96640A117
20	20	SCREW, 8-32, 1/2" LONG , STAINLESS STEEL	99461A240
21	1	MEMBRANE, KEYPAD	A042G192
22	1	COVER, DOOR PANEL	A042G194
23	1	PCB, DIGITAL PANEL, ELECTRONIC	A042G195
24	1	POWER PCB, DIGITAL PANEL, ELECTRONIC	A042G196
25	1	DISPLAY, COLOR TOUCH SCREEN	A042G199
26	1	STRAP, GROUND	A042G200
27	1	CABLE, DIGITAL PANEL, POWER PCB TO ECM SWITCH PCB	A042G202
28	1	LABEL, UL , ELECTRONIC CONTROL PANEL	A042G204
29	1	BEZEL, DISPLAY MOUNTING, FIRE PUMP DIGITAL PANEL	A042H037
30	1	COVER, DISPLAY, FIRE PUMP DIGITAL PANEL	A042H565
31	1	SWITCH, PUSHBUTTON, ABB CONTROL, CP110R-01	CP110R-01
32	1	CLIP, RIBBON CABLE, 25.6mm	FCM1-A-C14
33	1	COVER, HD10 W/LANYARD, DEUTSCH	HDC16-9-E004-L47N
34	1	HOLDER, TIE, ADHESIVE, NATURAL	RP302-ND

NOTES:  
1. TYPE 4X INDOOR USE CONSTRUCTION  
2. UPDATED SOFTWARE

This document contains confidential and trade secret information, is the property of Cummins Fire Power LLC and is to be used only for the intended purpose. The recipient, by receiving and retaining this document, agrees to maintain its confidentiality and to use it only for the intended purpose. If you are not the intended recipient, you should not disseminate, distribute or copy this document. If you have received this document in error, please notify the sender immediately by e-mail at [firepower@cumminsfirepower.com](mailto:firepower@cumminsfirepower.com). All rights reserved. ©2016 Cummins Fire Power LLC.

**Fire Power**  
CUMMINS FIRE POWER LLC  
CORPORATE OFFICE  
1600 BLUEBERRY ROAD  
WHITE BEAR LAKE, MN  
WWW.CUMMINSFIREPOWER.COM

CUSTOM DESIGN  
AND UPFIT CENTER  
875 LAWRENCE DRIVE  
DEPERE, WISCONSIN

UNLESS OTHERWISE SPECIFIED ALL DIMENSION TOLERANCES ARE		ANGULAR DIMENSIONS ± 1°		MACHINED SURFACES		IMPERIAL UNITS		METRIC UNITS		DWG UNITS:		DRAWN BY: PBS		DATE: 14SEP2016	
± .005		± .005		AS SHOWN		IN/LB/S		MM/KG		IN/LB/S		PRO-ENGINEER		INIT ECO: 2016-376	
A		2017-057		UPDATED PER A042H232		PBS		01FEB2017		SCALE: 0.500		SHEET 1 OF 2		DRAWING NO: A042G185	
REV		ECO		DESCRIPTION OF REVISION		REV BY		DATE		EST WEIGHT: 28.994					

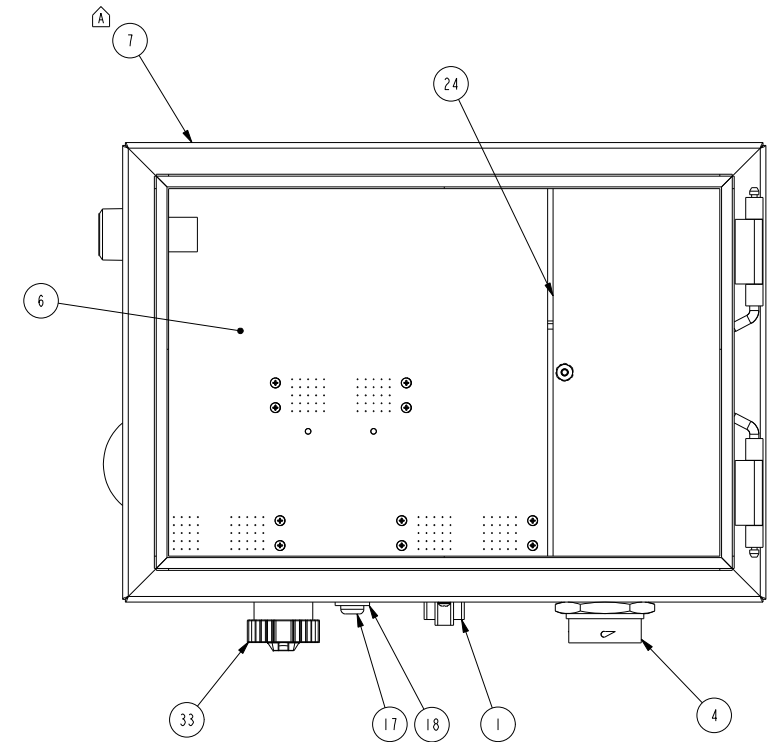
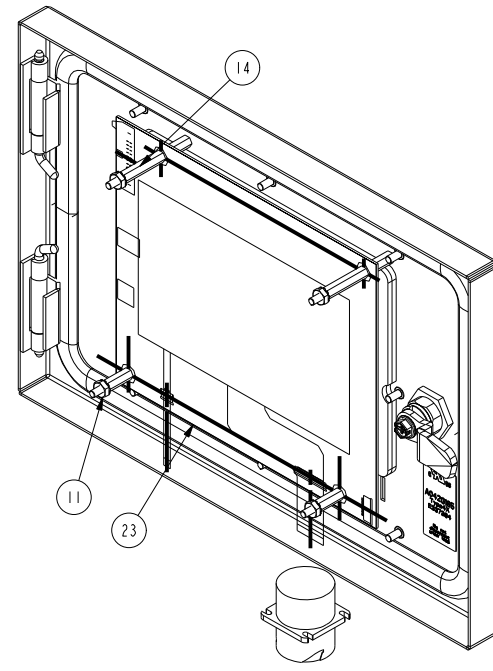
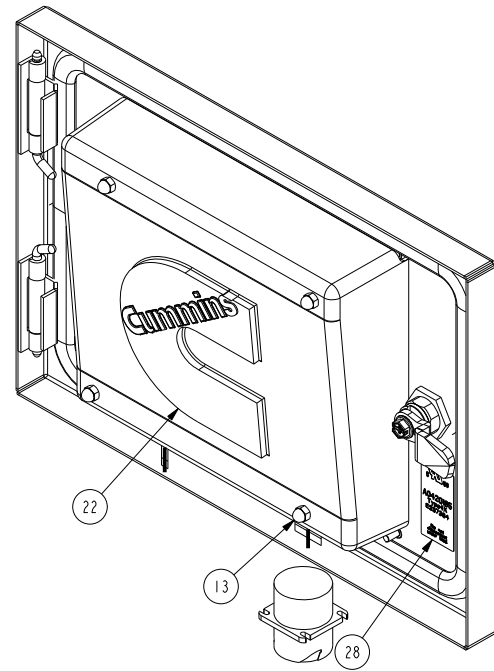
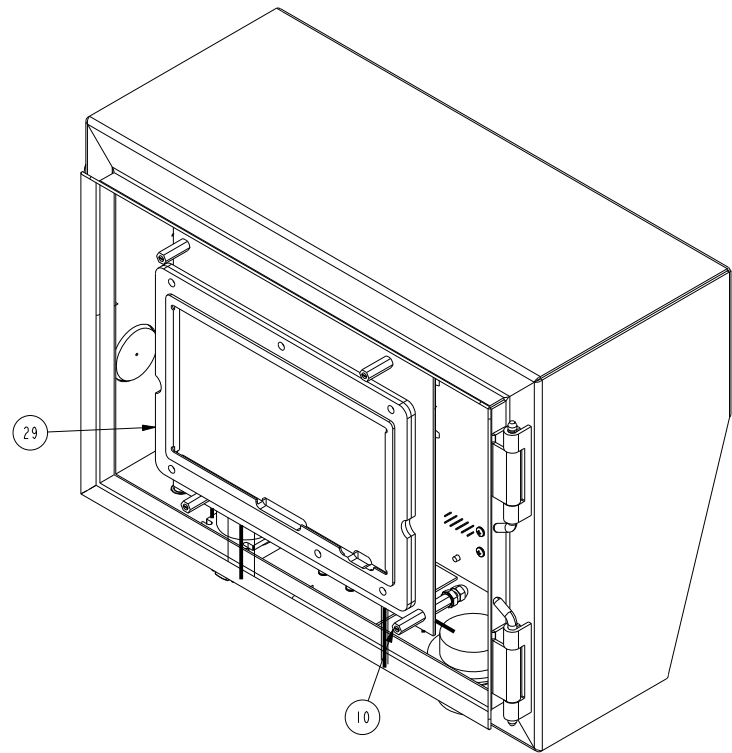
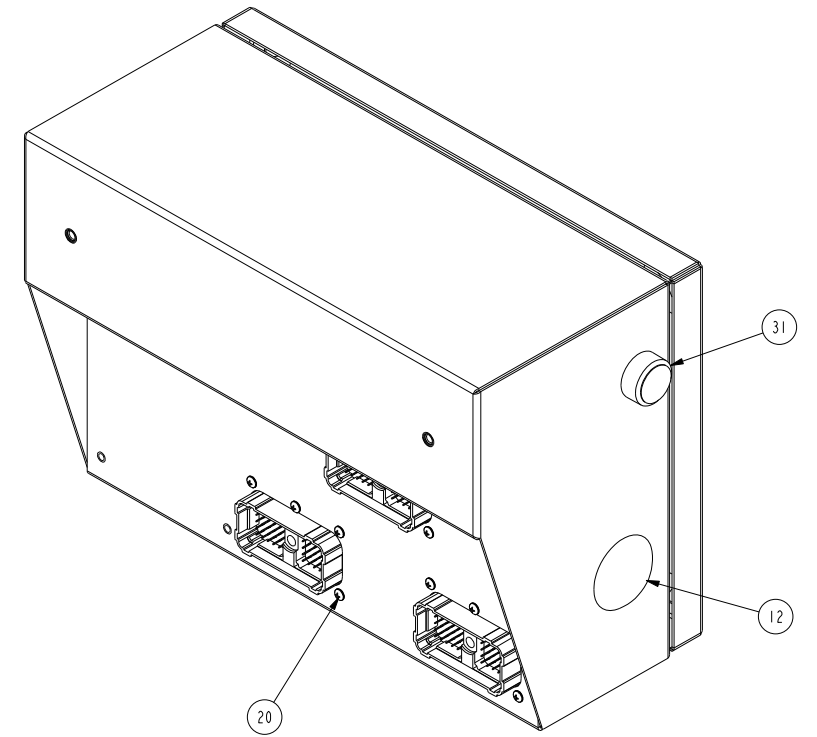
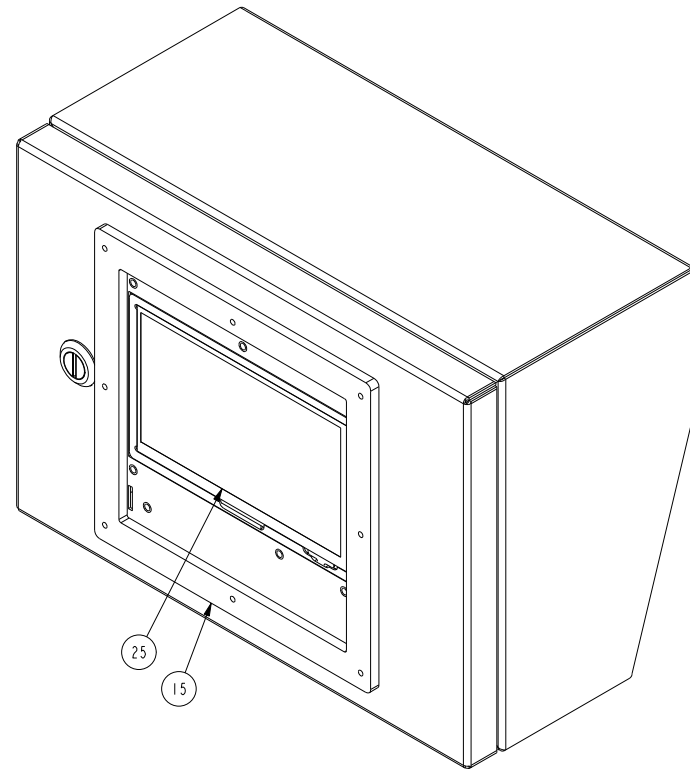
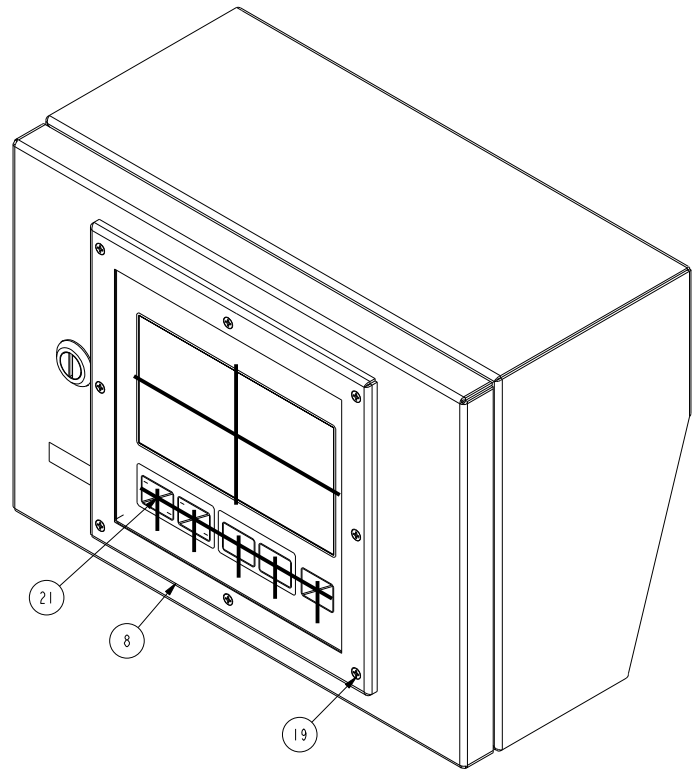

This document contains confidential and trade secret information, is the property of Cummins Fire Power, LLC and is to be used only for the purposes intended. The recipient of this document shall not disclose or disseminate the information contained herein, in whole or in part, to any third party without the prior written consent of Cummins Fire Power, LLC. If you are not an intended recipient, you should not disseminate, distribute or copy this document. If you have received this document by mistake, please notify the sender immediately by e-mail at [comms@firepower.com](mailto:comms@firepower.com). All information contained herein is confidential and proprietary to Cummins Fire Power, LLC. All rights reserved.

UNLESS OTHERWISE SPECIFIED ALL DIMENSION TOLERANCES ARE ANGULAR DIMENSIONS ± 1° MACHINED SURFACES IMPERIAL METRIC DWG UNITS: IN/LB/S PRO-ENGINEER DATE: 14SEP2016 INIT ECO: 2016-376 SHEET 2 OF 2 DRAWING NO: A042G185 EST WEIGHT: 28.994

**Fire Power** CUMMINS FIRE POWER LLC CORPORATE OFFICE 1600 BUECKLE ROAD WHITE BEAR LAKE, WI WWW.CUMMINSFIREPOWER.COM

ASSEMBLY, DIGITAL CONTROL PANEL ELECTRONIC CFP ENGINES

DRAWN BY: PBS

REV	ECO	DESCRIPTION OF REVISION	REV BY	DATE
A	2017-057	SEE SHEET 1 FOR LATEST REVISION DETAILS	PBS	01FEB2017

BILL OF MATERIAL

ITEM	QTY	DESCRIPTION	PART NUMBER
1	1	CONTACTOR, MANUAL OVERRIDE, 12V, PN:535-0127, FIREPUMP	8824-12
2	1	CONTACTOR, MANUAL OVERRIDE, 24V, PN:535-0098, FIREPUMP	8824-24

1 2 3 4 5 6 7

PRO0010

DESIGN APPROVAL DATE UNPECIFIED TOLERANCES  
 DES.ENG. JOK ±.005  
 MFG.ENG. JOK ±.010  
 Q.C. JOK Machine Finish ±.005 Max.  
 SALES JOK Angles ±1°  
 Concentricity .005 TIR  
 Squareness .001 per ft.

This Drawing is the property of the Dumore Corporation. It must not be reproduced or copied without written permission.

PART NO. 535-0127  
**DUMORE CORPORATION**  
 1030 VETERANS ST. MAUSTON, WI 53948

DO NOT SCALE DRAWING REMOVE ALL BURRS BREAK SHARP CORNERS  
 TITLE ASSEMBLY, SOLENOID

MATERIAL SPEC: Rec. per Piece Pattern No. RECEIVED AS DWG. BY CTH DATE 7/19/01 SCALE 1:2  
 Q.C. BY DATE

REVISIONS  
 RELEASED ECN # 25159 7/19/01 CTH

THE 535-0127 SOLENOID ASSEMBLY MUST BE INSTALLED IN A NEMA 2 ENVIRONMENT

ELECTRICAL SPECIFICATIONS  
 VOLTS: 12 VDC  
 CONTACT RATING: 400 AMPS (ROLLING CURRENT)  
 800 AMPS (BREAKAWAY CURRENT)  
 DUTY TYPE: INTERMITTENT  
 CONTACT POSITION: NORMALLY OPEN

WHERE USED

3.00 ± .06  
 2.34 ± .03  
 17° - 20°  
 5.74  
 2.65 ± .03  
 .275  
 .255 TYP (4)  
 .50 1.75  
 6.00 ± .03

30° 30°  
 10-32 UNF-2A THREAD TYP.(2)  
 3/8-16 UNC-2A THREAD TYP.(2)  
 U.L. & FACTORY MUTUAL DECAL.  
 1.99 ± .03 TYP.  
 1.90  
 .354  
 .334  
 1.50  
 3.00  
 3.63 ± .03  
 4.88 ± .06  
 .28

ITEM:1 - 8824-12

1 2 3 4 5 6 7

SP4847

DESIGN APPROVAL DATE UNPECIFIED TOLERANCES  
 DES.ENG. JOK ±.005  
 MFG.ENG. JOK ±.010  
 Q.C. JOK Machine Finish ±.005 Max.  
 SALES JOK Angles ±1°  
 Concentricity .005 TIR  
 Squareness .001 per ft.

This Drawing is the property of the Dumore Corporation. It must not be reproduced or copied without written permission.

PART NO. 535-0098  
**DUMORE CORPORATION**  
 1030 VETERANS ST. MAUSTON, WI 53948

DO NOT SCALE DRAWING REMOVE ALL BURRS BREAK SHARP CORNERS  
 TITLE ASSEMBLY, SOLENOID

MATERIAL SPEC: Rec. per Piece Pattern No. RECEIVED AS DWG. BY MED DATE 2/16/89 SCALE 1:2  
 Q.C. BY DATE 8/13/91

REVISIONS

THE 535-0098 SOLENOID ASSEMBLY MUST BE INSTALLED IN A NEMA 2 ENVIRONMENT

ELECTRICAL SPECIFICATIONS  
 VOLTS: 24 VDC  
 CONTACT RATING: 400 AMPS (ROLLING CURRENT)  
 800 AMPS (BREAKAWAY CURRENT)  
 DUTY TYPE: INTERMITTENT  
 CONTACT POSITION: NORMALLY OPEN

3.00 ± .06  
 2.34 ± .03  
 17° - 20°  
 5.74  
 2.65 ± .03  
 .275  
 .255 TYP (4)  
 .50 1.75  
 6.00 ± .03

30° 30°  
 10-32 UNF-2A THREAD TYP.(2)  
 3/8-16 UNC-2A THREAD TYP.(2)  
 U.L. & FACTORY MUTUAL DECAL.  
 1.99 ± .03 TYP.  
 1.90  
 .354  
 .334  
 1.50  
 3.00  
 3.63 ± .03  
 4.88 ± .06  
 .28

ITEM:2 - 8824-24

REV	ECO	DESCRIPTION OF REVISION	REV BY	DATE
A	2011-068	UPDATED DRAWING FORMAT ADDED CNP LABEL TO PDF DRAWING	MAC	18FEB2011

This document contains confidential and trade secret information, is the property of Cummins Fire Power LLC and is given to the receiver in confidence. The receiver, by receiving and retaining of the document accepts the document in confidence and agrees that, except as authorized in writing by Cummins Fire Power, it will (1) not use the document or any copy thereof or the confidential or trade secret information therein, (2) not copy the document, (3) not disclose to others either the document or the confidential or trade secret information therein, and (4) upon completion of the need to retain the document, or upon demand, return the document, all copies thereof, and all material copied therefrom. COPYRIGHT Cummins Fire Power LLC

**Cummins Fire Power**

CUMMINS FIRE POWER LLC  
 CORPORATE OFFICE  
 1600 BUERKLE ROAD  
 WHITE BEAR LAKE, MN  
 WWW.CUMMINSFIREPOWER.COM

CUSTOM DESIGN AND UPFIT CENTER  
 875 LAWRENCE DRIVE  
 DEPERE, WISCONSIN

MANUAL SOLENOID

UNLESS OTHERWISE SPECIFIED ALL DIMENSION TOLERANCES ARE

ANGULAR DIMENSIONS ± 1°	IMPERIAL UNITS	METRIC UNITS
THIRD ANGLE PROJECTION	MACHINE TOLERANCES .XX ± 0.010 .XX ± 0.005	MACHINE TOLERANCES .X ± 0.2 .X ± 0.1
	FORM TOLERANCES .XX ± 0.020 .XX ± 0.015	FORM TOLERANCES .X ± 0.8 .X ± 0.4
	FAB TOLERANCES .XX ± 0.080 .XX ± 0.030	FAB TOLERANCES .X ± 1.5 .X ± 0.8

DWG UNITS: IN/LB/S  
 DRAWN BY: CMC  
**PRO-ENGINEER**  
 DATE: 12JUNE2004  
 INIT ECO: -

SCALE: 1.000  
 EST WEIGHT: 42238.628  
 SHEET 1 OF 1  
 DRAWING NO: 8824

BILL OF MATERIAL			
ITEM	QTY	DESCRIPTION	PART NUMBER
1	1	BUSHING, REDUCING PIPE; -6 NPT X -2 FNPT, STEEL	12176-6-2
2	1	BUSHING, REDUCING PIPE; -8 NPT X -2 FNPT, STEEL	12176-8-2
3	1	CONNECTOR, FEMALE; M14 ORR X -4 FNPT, STEEL	12181-M14-4
4	1	FTG. TEE, RUN; -6 NPT	12204-6
5	1	FTG. TEE, RUN; -8 NPT	12204-8
6	2	PLUG, PIPE; EXT HEX -2 NPT, STEEL	12210-2
7	1	PLUG, PIPE; EXT HEX -6 NPT, STEEL	12210-6
8	1	PLUG, PIPE; EXT HEX -8 NPT, STEEL	12210-8
9	1	UNION, MALE; -6 JIC X -10 ORB, STEEL	12235-6-10
10	1	UNION, MALE; -8 JIC X -10 ORB, STEEL	12235-8-10
11	1	CONNECTOR, FEMALE; -6 JIC X -6 FNPT, STEEL	12240-6-6
12	1	CONNECTOR, FEMALE; -8 JIC X -8 FNPT, STEEL	12240-8-8
13	1	COUPLING, ELBOW HOSE; 90D -4 BARB X -4 NPT, BRS	12546-4-4
14	1	HOSE, FUEL LINE, 221FR-5 X 20" LG; NO ENDS	14398
15	2	CLAMP, WORM; 5/16" BAND	14992-04
16	2	CLAMP, WORM; 5/16" BAND	14992-06
17	1	ASSEMBLY, HOSE, FUEL LINE; CFPSE RETURN	15265
18	1	HOSE, FUEL; CFPSE	A042H712
19	1	HOSE, FUEL; CFPSE	A042H713

REV	REL NO	REVISION	DWN	CKD	APVD	DATE
-	2016-376	INITIAL RELEASE	PBS	-	-	15SEP16
1	2020-319	ADDED 12204-6, 12204-8, 12210-2 QTY(2) 12176-6-2, 12176-8-2, VIEWS & NOTES	KMS	JJW	JJW	02SEP20

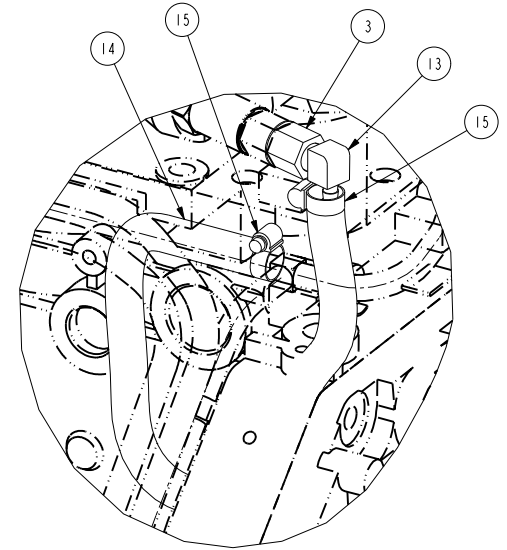
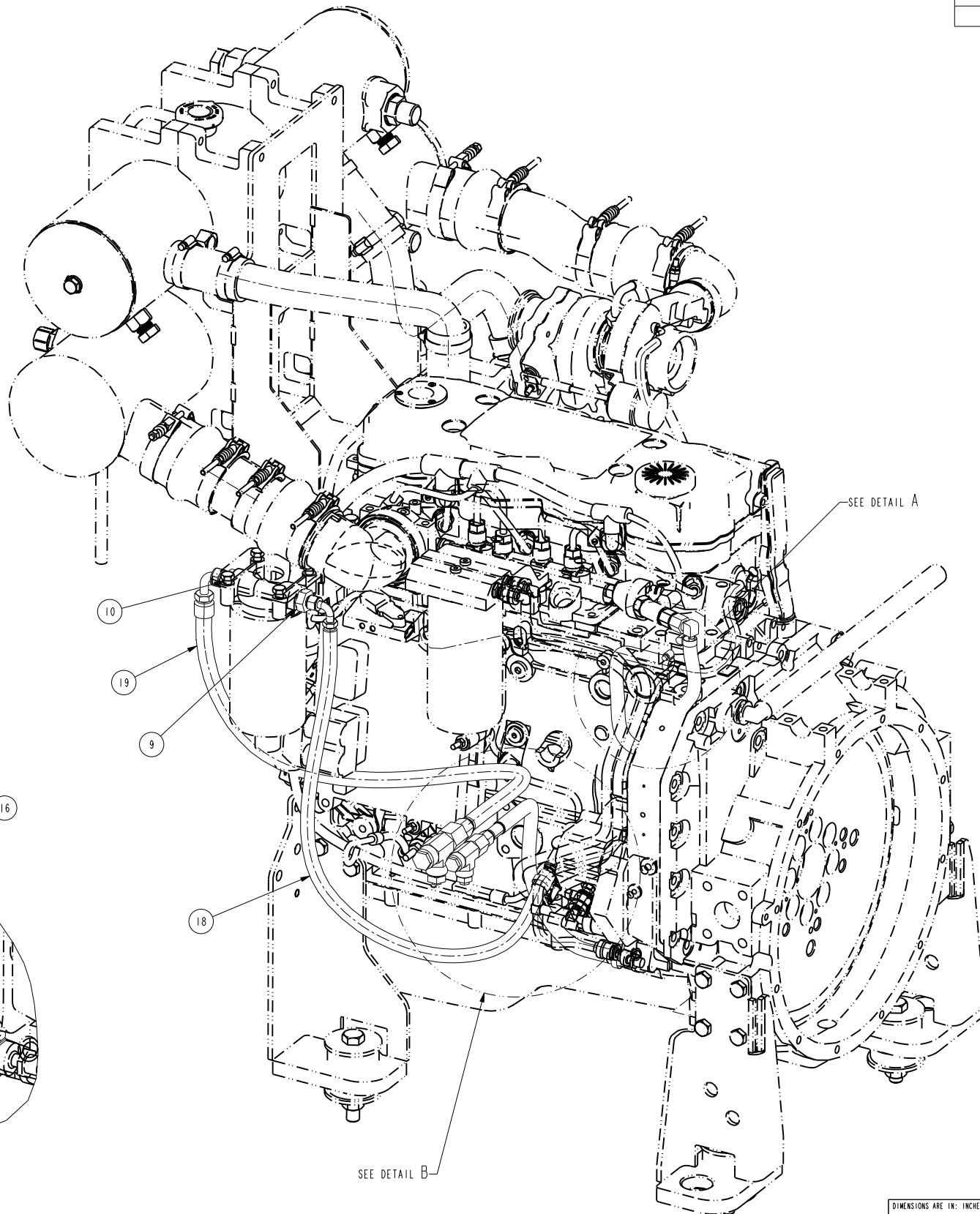

DETAIL A  
SCALE 0.625

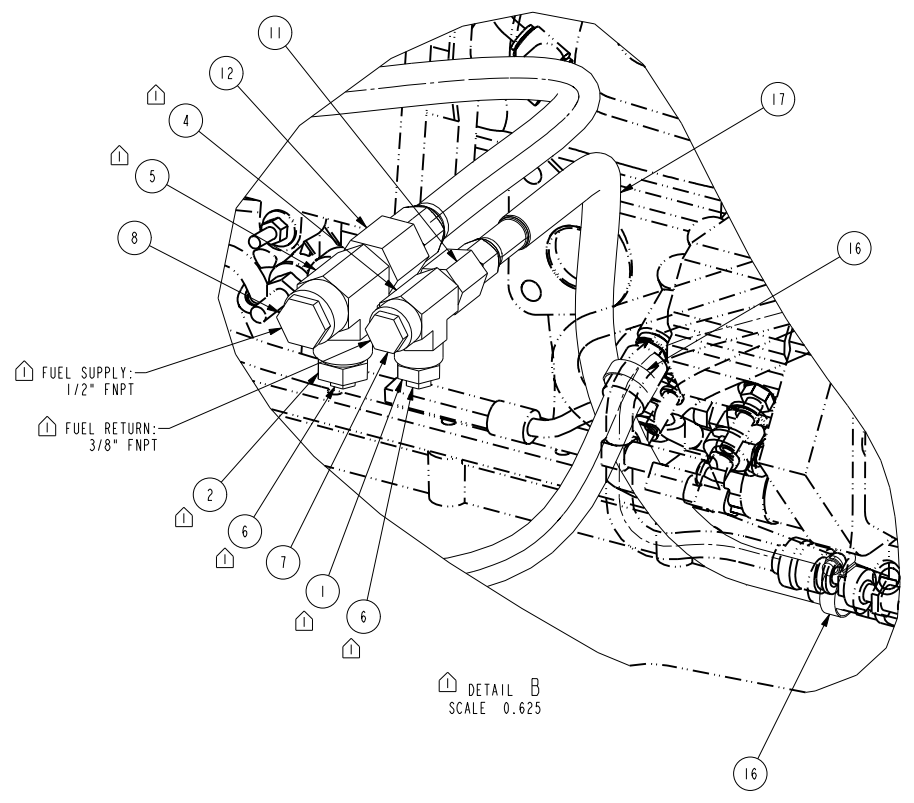

DETAIL B  
SCALE 0.625

FUEL SUPPLY:  
1/2" FNPT

FUEL RETURN:  
3/8" FNPT

NOTES:  
1. ADD THREAD SEALANT TO ALL NPT THREADS

DIMENSIONS ARE IN: INCHES ( ) ARE IN:	DO NOT SCALE PRINT	CMI DATA CLASSIFICATION Cummins Confidential		Cummins Inc.	
	SCALE 0.313	DWN: P.B. SALM		ITEM NAME ASSEMBLY, FUEL LINE CFPSE	
DRAWING TOLERANCES APPLY TO PRIMARY DIMENSIONS UNLESS OTHERWISE SPECIFIED F: ± 0.004 IN OR 0.10 mm M: ± 0.003 IN OR 0.07 mm H: ± 0.002 IN OR 0.05 mm L: ± 0.001 IN OR 0.025 mm ANGULAR TOLERANCE: ± 0.005°		DATE: 15SEP2016	FOR INTERPRETATION OF DIMENSIONING AND TOLERANCING, SEE ASME Y14.5-2009	MUST CONFORM TO CES 10903	CAD SHEET 1 OF 1
THIS DOCUMENT (AND THE INFORMATION SHOWN THEREON) IS CONFIDENTIAL AND PROPRIETARY AND SHALL NOT BE DISCLOSED TO OTHERS IN HARD COPY OR ELECTRONIC FORM, REPRODUCED BY ANY MEANS, OR USED FOR ANY PURPOSE WITHOUT WRITTEN CONSENT OF CUMMINS INC.				ITEM NUMBER A042H710	REV 1



BILL OF MATERIAL			
ITEM	QTY	DESCRIPTION	PART NUMBER
1	1	HOSE, ISOLATED COOLING LOOP	15299
2	1	HOSE, COOLING LOOP TO CAC, CFP5E	26159
3	1	FTG. STR. -12 JIC X -12 FMNPT	12240-12-12
4	2	ELB, 90 DEG, -12 JIC X -12 NPT	12270-12-12
5	2	HOSE END, 90, -12 JIC X -12 HS	14591-12-12
6	2	CLAMP, PIPE, 3/4", PLASTIC	14926
7	2	CLAMP, WORM, .56-1.06	14990-10
8	1	CAP, PVC, NPT FEMALE, 3/4" NPT	16663-12
9	4	WASHER, FLAT, SMALL, 0.25	20020
10	2	BRACKET, MOUNTING, COOLING LOOP, 10" STAND OFF	26133
11	1	BRACKET, PIPE SUPPORT, ISOLATED FIRE PUMP	26134
12	1	NIPPLE, BLK, 3/4x6	71550
13	2	U-BOLT, 1-1/8" OD PIPE, W/NUTS	3201T13
14	1	DECAL, VALVE POSITION, CFP5E	A042D485
15	1	HOSE, SILICONE, 3/4IN ID x 4.00IN LONG	A042F073

REV	REL NO	REVISION	DWN	CKD	APVD	DATE
-	2013-458	RELEASED TO PRODUCTION	HE392	-	-	08AUG13
E	2018-084	DELETE: A042B375. ADD 26133. CHG QTY 14926 WAS 4	HE392	MS707	MS707	13FEB18
F	2019-188	REPLACED 14990-12 W/ 14990-10 & 13257 W/ A042F073	NO134	MS707	MS707	19APR19

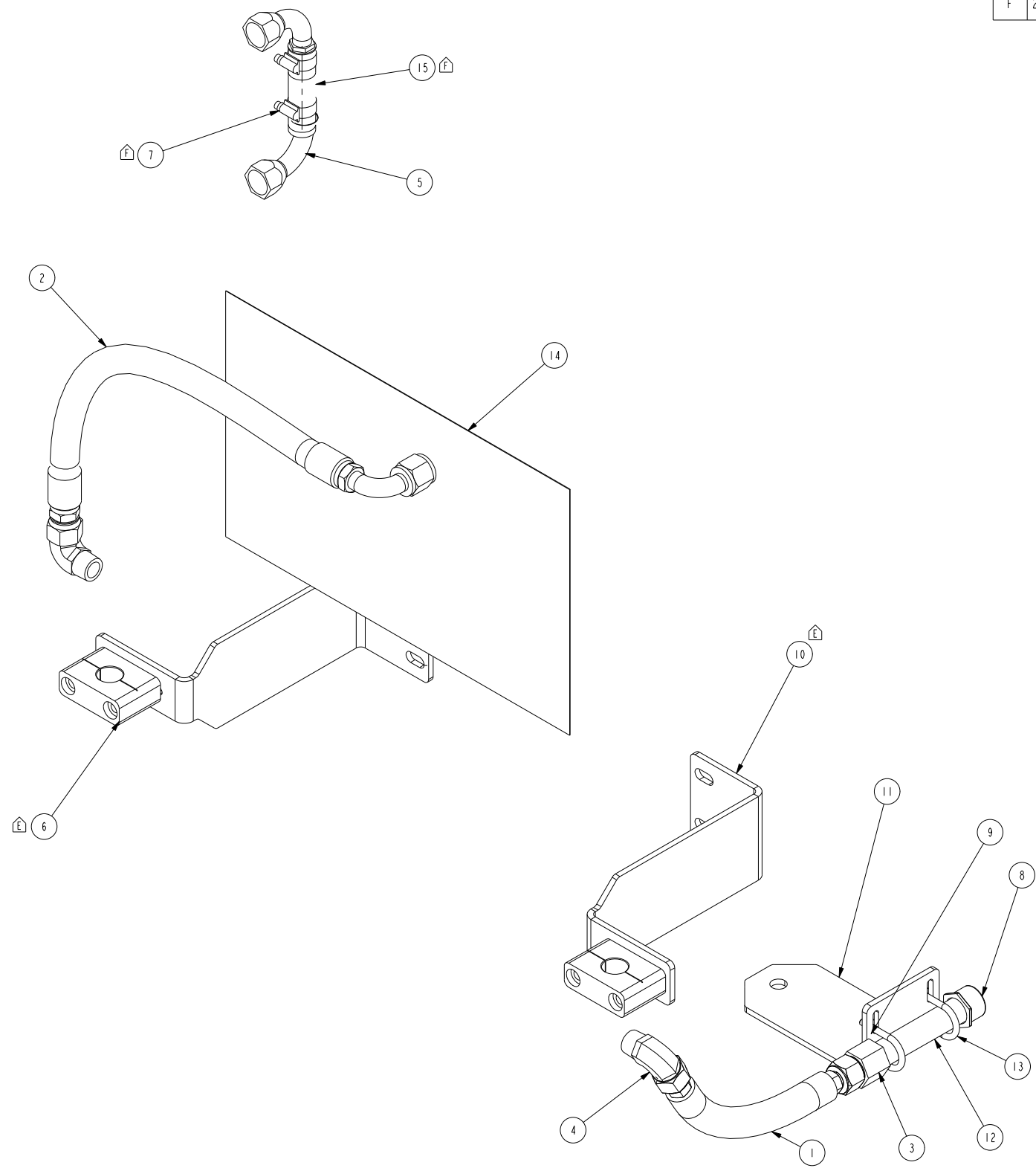

NOTE:  
1. REFERENCE DRAWING 26105 FOR INSTALLATION ON THE POWER UNIT

DIMENSIONS ARE IN: INCHES [ ] ARE IN: .	<b>DO NOT SCALE PRINT</b> SCALE 0.375	CMI DATA CLASSIFICATION Cummins Confidential		<b>Cummins Inc.</b>	
				ITEM NAME ASSEMBLY, MISC PIPING CFP5E	
DRAWING TOLERANCES UNLESS OTHERWISE SPECIFIED: X: ± 1 IN OR 4 mm Y: ± 1 IN OR 0.7 mm Z: ± .010 IN OR 0.25 mm X, Y, Z: ± .010 IN OR 0.25 mm ANGULAR TOLERANCES: ± °	FOR INTERPRETATION OF DIMENSIONING AND TOLERANCING, SEE ASME Y14.5-2009	MUST CONFORM TO CES 10903	CAD SHEET 1 OF 1	ITEM NUMBER 26132	REV F

BILL OF MATERIAL			
ITEM	QTY	DESCRIPTION	PART NUMBER
1	1	SENDER, WATER TEMPERATURE; 1/8" NPT	8862
2	2	REGULATOR, 3/4" NPT, 400 PSI MAX; 25 TO 75 PSI OUT	8890
3	2	STRAINER, 3/4" NPT W/ PLUG;	8891
4	1	GAUGE, PRESSURE, 1/4" NPT; DPG1-2 1/2, 0-100 PSI, (WATTS)	8892
5	2	FTG. STR; MALE NPT TO FEMALE METRIC ORB	12177-4-M14
6	2	VALVE,BALL,3/4NPT; BRASS, LOCKABLE	21504
7	1	CROSS,3/4NPT,STEEL; SCHEDULE 40 PIPE	21519
8	2	VALVE, 3/4" NPT CHECK; VALUE ADDED: CV075	25502
9	2	SEAL, METRIC BONDED; ADAPTALL 9500MM SERIES	26984-14
10	4	BUSHING,3/4" NPT X 1/4" NPT; -	71494
11	4	NIPPLE, BLK, 3/4x6;	71550
12	1	VALVE, BALL, 1/4" NPT FEMALE;	A042D838
13	2	PLUG, THREADED, M14x1.5; McMASTER-CARR: 5481K25	A060R226
14	1	NIPPLE, 1/4" NPT x 1 1/2"; BLK STEEL	LTL-CPN14112
15	10	NIPPLE, BLK, 3/4x1-1/2;	LTL-CPN34
16	1	ELBOW, BLK, 3/4" NPT, 90 DEG.;	LTL-E3490
17	2	PLUG, 1/2 NPT;	LTL-SCSP12
18	1	REDUCER BUSHING, HEX: 1/4 x 1/8, BLK STEEL	LTL-SRB1418
19	4	TEE, BLACK PIPE; NPT	LTL-ST34

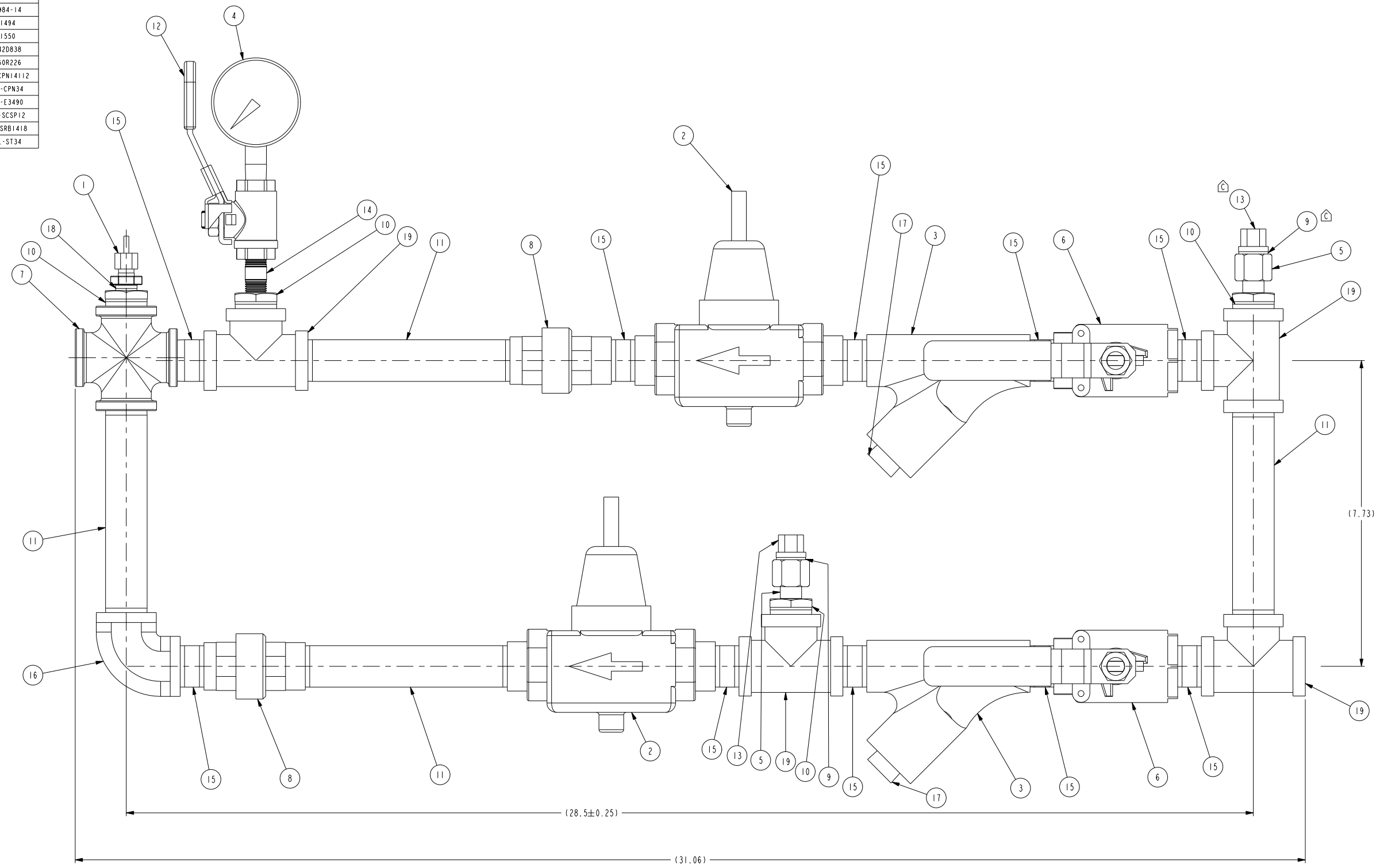

REV	REL NO	REVISION	DWN	CKD	APVD	DATE
-	2016-376	INITIAL RELEASE	PBS			12SEP16
C	2018-360	DELETE: 12210-4; ADDED: A060R226, 26984-1 & NOTE	HE392			03JUL18
4	2020-064	ADDED STRAINER SCREEN & O-RING NOTE	RE123	MS707	MS707	30JAN20



- NOTES:
- MATERIAL: SEE PARTS LIST
  - REMOVE ALL SHARP EDGES PRIOR TO COATING
  - LEAK TEST TO 60PSI AND PRESET REGULATORS TO 60PSI
  - FINISH: COAT PER CUMMINS SPEC ES044 RAL 3001
  - CAP ALL PORTS PRIOR TO SHIPPING
  - REPLACEMENT COMPONENTS FOR ITEM 8891:  
REPLACEMENT STRAINER SCREEN P/N: A0632526  
REPLACEMENT O-RING P/N: A0632527

DIMENSIONS ARE IN: INCHES 1.1 ARE IN: -	DO NOT SCALE PRINT SCALE 0.750	CWI DATA CLASSIFICATION Cummins Confidential		Cummins Inc.	
DRAWING TOLERANCES APPLY TO PRIMARY DIMENSIONS UNLESS OTHERWISE SPECIFIED X.1: ± 1 IN OR 4 mm X.2: ± 1 IN OR 3.7 mm X.3: ± .030 IN OR 0.25 mm X.4: ± .010 IN OR 0.25 mm ANGULAR TOLERANCE: ±	DWN: PBS CKD: - APVD: - DATE: 12SEP16	FOR INTERPRETATION OF DIMENSIONING AND TOLERANCING: SEE ASME Y14.5-2009		ITEM NAME COOLING LOOP, 3/4" VERT RAW WATER	CAD SHEET 1 OF 2
MUST CONFORM TO CES 10903					REV 4

Assembly	Component	Manufacture/pn	Description	Sub-Component	Material	Specification
A042H724	21504	RUB, S95E45	3/4" Vertical, Raw Water 3/4" ball valve	body	brass CW617N	EN12165
				seal	PTFE	
				ball	brass CW617N	EN12165
				end cap	brass CW617N	EN12165
				stem	brass CW617N	EN12164
				nut	CB4FF	EN10263-2
				O-ring	FPM	
				handle	DD11	EN10111
				handle coating	PVC	
				washer	PTFE	
	8862	Datcon, 02022-00	temperature sender	body	brass	
	8890	Watts, N45BU-MI-3/4"	regulator	body	bronze	
				seal	thermoplastic	
				cage	thermoplastic	
				integral strainer	stainless steel	
				diaphragm	reinforced EPDM	
				valve disc	elastomer	
	8891	Watts, 77S-MI-3/4"	strainer	body	cast iron	
				retainer cap	cast iron	ASTM A-126 Class B
				screen	304 stainless steel	
	8892	Watts, DPG1-2	pressure gauge	case	ABS polymer	
				window	Kostil polymer	
				sensing element	copper alloy Bourdon tube	
				welding	tin alloy	
				connection	brass	
A042D838	RUB, S95B45		1/4" ball valve	body	CW617N	EN12165
				seal	PTFE	
				ball	CW617N	EN12165
				end cap	CW617N	EN12165
				stem	CW617N	EN12164
				nut	CB4FF	EN10263-2
				O-ring	FPM	
				handle	DD11	EN10111
				handle coating	PVC	
				washer	PTFE	
	21519		3/4" cross		black steel	ASTM A53/A733
	25502	Euroblock, 100002	3/4" check valve	body	brass CW617N	EN12165
				end connection	brass CW617N	EN12165
				disc	polyetherimide	
				seal	NBP	
				spring	stainless steel	
	71494		3/4" x 1/4" reducing bushing		black steel	ASTM A53/A733
	71550		3/4" x 6" nipple		black steel	ASTM A53/A733
	LTL-CPN14112		1/4" x 1-1/2" nipple		black steel	ASTM A53/A733
	LTL-CPN34		3/4" x 1-1/2" nipple		black steel	ASTM A53/A733
	LTL-E3490		3/4", 90° elbow		black steel	ASTM A53/A733
	LTL-SCSP12		1/2" NPT plug		black steel	ASTM A53/A733
	LTL-SRB1418		1/4" x 1/8" reducing bushing		black steel	ASTM A53/A733
	LTL-ST34		3/4" TEE		black steel	ASTM A53/A733
	12177-4-M14		fig. str. 1/4-18 to M14x1.5		steel, zinc plated	

DIMENSIONS ARE IN: INCHES [ ] ARE IN: -	DO NOT SCALE PRINT SCALE 0.750	CWI DATA CLASSIFICATION Cummins Confidential	 <b>Cummins Inc.</b> ITEM NAME <b>COOLING LOOP, 3/4" VERT          RAW WATER</b>
DRAWING TOLERANCES APPLY TO PRIMARY DIMENSIONS UNLESS OTHERWISE SPECIFIED X.1: ± 1/16 IN OR 1.6 mm X.2: ± 1/32 IN OR 0.7 mm X.3: ± 0.01 IN OR 0.25 mm X.4: ± 0.005 IN OR 0.125 mm ANGULAR TOLERANCE: ±	 DATE 12SEP16 FOR INTERPRETATION OF DIMENSIONING AND TOLERANCING SEE ASME Y14.5-2009	DWG - PBS CKD - APVD - MUST CONFORM TO CES 10903	

BILL OF MATERIAL			
ITEM	QTY	DESCRIPTION	PART NUMBER
1	1	SENDER, WATER TEMPERATURE; 1/8" NPT	8862
2	2	REGULATOR, 3/4" NPT, 400 PSI MAX; 25 TO 75 PSI OUT	8890
3	2	STRAINER, 3/4" NPT W/ PLUG;	8891
4	1	GAUGE, PRESSURE, 1/4" NPT; DPG1-2 1/2, 0-100 PSI, (WATTS)	8892
5	2	FTG. STR; MALE NPT TO FEMALE METRIC ORB	12177-4-M14
6	2	VALVE,BALL,3/4NPT; BRASS, LOCKABLE	21504
7	1	CROSS,3/4NPT,STEEL; SCHEDULE 40 PIPE	21519
8	2	VALVE, 3/4" NPT CHECK; VALUE ADDED: CV075	25502
9	2	SEAL, METRIC BONDED; ADAPTALL 9500MM SERIES	26984-14
10	4	BUSHING,3/4" NPT X 1/4" NPT; -	71494
11	3	NIPPLE, BLK, 3/4x6;	71550
12	1	VALVE, SOLENOID, 3/4" NPT, 12VDC;	A042B123
13	1	VALVE, BALL, 1/4" NPT FEMALE;	A042D838
14	2	PLUG, THREADED, M14x1.5; McMASTER-CARR: 5481N25	A060R226
15	1	NIPPLE, 1/4" NPT x 1 1/2"; BLK STEEL	LTL-CPN14112
16	12	NIPPLE, BLK, 3/4x1-1/2;	LTL-CPN34
17	1	ELBOW, BLK, 3/4" NPT, 90 DEG.;	LTL-E3490
18	2	PLUG, 1/2 NPT;	LTL-SCSP12
19	1	REDUCER BUSHING, HEX; 1/4 x 1/8, BLK STEEL	LTL-SRB1418
20	4	TEE, BLACK PIPE; NPT	LTL-ST34

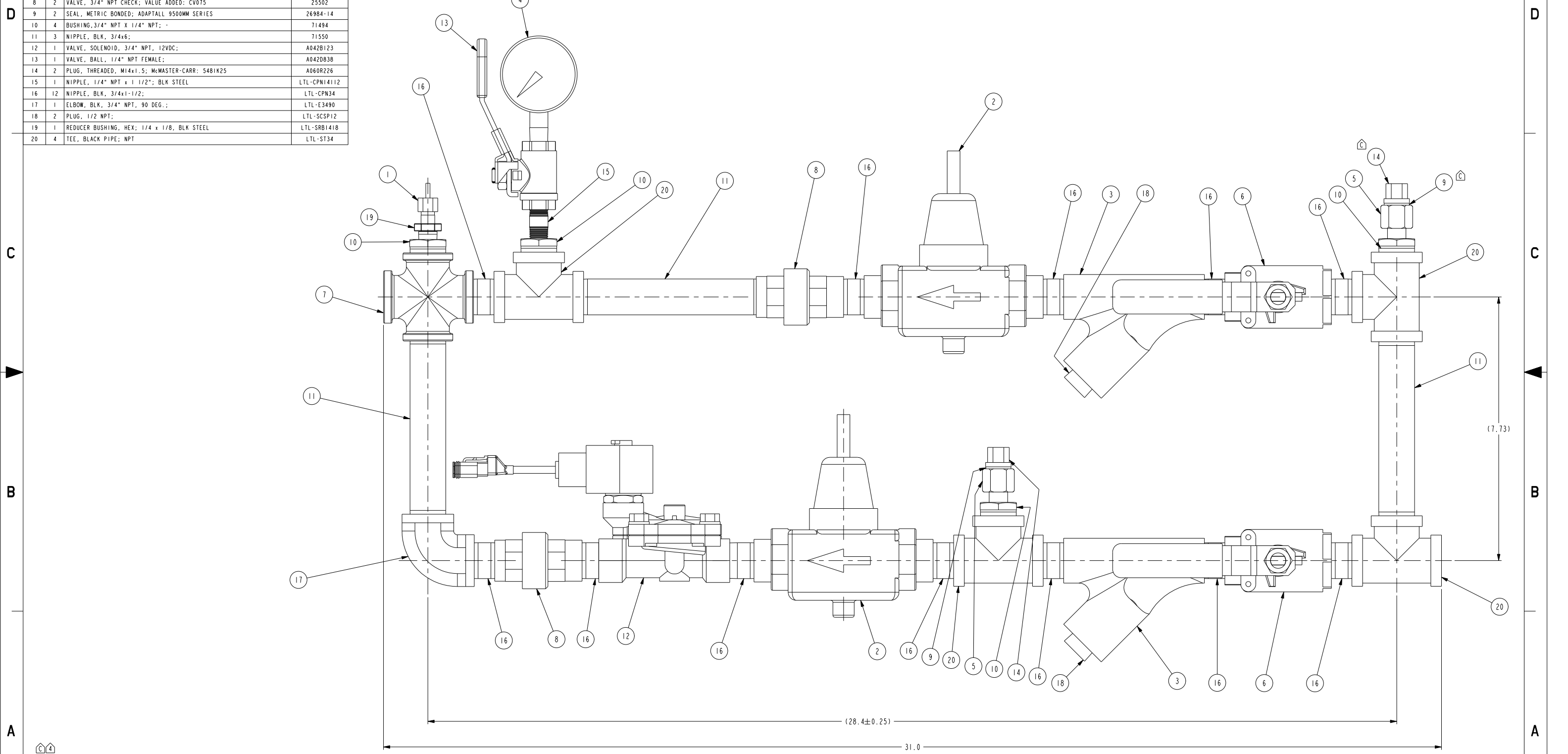

REV	REL NO	REVISION	DWN	CKD	APVD	DATE
-	2016-376	INITIAL RELEASE	PBS			12SEP16
C	2018-360	DELETE: 12210-4; ADDED: A060R226, 26984-1 AND NOTE	HE392			03JUL18
4	2020-064	ADDED STRAINER SCREEN & O-RING NOTE	RE123	MS707	MS707	30JAN20



NOTES:  
 1. MATERIAL: SEE PARTS LIST  
 2. REMOVE ALL SHARP EDGES PRIOR TO COATING  
 3. LEAK TEST TO 60PSI AND PRESET REGULATORS TO 60PSI  
 4. FINISH: COAT PER CUMMINS SPEC ES044 RAL 3001  
 5. CAP ALL PORTS PRIOR TO SHIPPING  
 6. REPLACEMENT COMPONENTS FOR ITEM 8891:  
 REPLACEMENT STRAINER SCREEN P/N: A063Z526  
 REPLACEMENT O-RING P/N: A063Z527

DIMENSIONS ARE IN: INCHES 1.1 ARE IN: -	DO NOT SCALE PRINT SCALE 0.750	CWI DATA CLASSIFICATION Cummins Confidential		Cummins Inc.			
DRAWING TOLERANCES APPLY TO PRIMARY DIMENSIONS UNLESS OTHERWISE SPECIFIED X.1: ± 1 IN OR 4 mm X.2: ± 1 IN OR 3.7 mm X.3: ± .030 IN OR 0.25 mm X.4: ± .010 IN OR 0.25 mm ANGULAR TOLERANCE: ±	DWN: PBS CKD: - APVD: - DATE: 12SEP16	FOR INTERPRETATION OF DIMENSIONING AND TOLERANCING: SEE ASME Y14.5-2009		MUST CONFORM TO CES 10903	ITEM NAME COOLING LOOP, 3/4", 12V RAW WATER	CAD SHEET 1 OF 2	ITEM NUMBER A042H725

Assembly	Component	Manufacture/pn	Description	Sub-Component	Material	Specification
A042H725	21504	RUB, S95E45	3/4" 12VDC, Raw Water 3/4" ball valve	body	CW617N	EN12165
				seat	PTFE	
				ball	CW617N	EN12165
				end cap	CW617N	EN12165
				stem	CW617N	EN12164
				nut	CB4FF	EN10263-2
				O-ring	FPM	
				handle	DD11	EN10111
				handle coating	PVC	
				washer	PTFE	
	A042B123	Asco, 8210G003-12V	3/4" NPT 12V solenoid valve	body	brass	
				seals and discs	NBR or PTFE	
				disc holder	PA	
				core tube	305 stainless steel	
				core and plugnut	430F stainless steel	
				springs	302 stainless steel	
				shading coil	copper	
	8862	Datcon, 02022-00	temperature sender	Body	brass	
	8890	Watts, N45BU-MI-3/4"	regulator	body	bronze	
				seat	thermoplastic	
				cage	thermoplastic	
				integral strainer	stainless steel	
				diaphragm	reinforced EPDM	
				valve disc	elastomer	
	8891	Watts, 77S-MI-3/4"	strainer	body	cast iron	
				retainer cap	cast iron	ASTM A-126 Class B
				screen	304 stainless steel	
	8892	Watts, DPG1-2	pressure gauge	case	ABS polymer	
				window	Kasil polymer	
				sensing element	copper alloy Bourdon tube	
				welding	tin alloy	
				connection	brass	
	A042D838	RUB, S95B45	1/4" ball valve	body	CW617N	EN12165
				seat	PTFE	
				ball	CW617N	EN12165
				end cap	CW617N	EN12165
				stem	CW617N	EN12164
				nut	CB4FF	EN10263-2
				O-ring	FPM	
				handle	DD11	EN10111
				handle coating	PVC	
				washer	PTFE	
	21519		3/4" cross		black steel	ASTM A53/A733
	25502	Euroblock, 100002	3/4" check valve	body	brass CW617N	EN12165
				end connection	brass CW617N	EN12165
				disc	polyetherimide	
				seat	NBP	
				spring	stainless steel	
	71494		3/4" x 1/4" reducing bushing		black steel	ASTM A53/A733
	71550		3/4" x 6" nipple		black steel	ASTM A53/A733
	LTL-CPN14112		1/4" x 1-1/2" nipple		black steel	ASTM A53/A733
	LTL-CPN34		3/4" x 1-1/2" nipple		black steel	ASTM A53/A733
	LTL-E3490		3/4", 90° elbow		black steel	ASTM A53/A733
	LTL-SCSP12		1/2" NPT plug		black steel	ASTM A53/A733
	LTL-SRB1418		1/4" x 1/8" reducing bushing		black steel	ASTM A53/A733
	LTL-ST34		3/4" TEE		black steel	ASTM A53/A733
	I2177-4-M14		ftg. str, 1/4-18 to M14x1.5		steel, zinc plated	

DIMENSIONS ARE IN: INCHES [ ] ARE IN: -	DO NOT SCALE PRINT SCALE 0.750	CWI DATA CLASSIFICATION Cummins Confidential	 <b>Cummins Inc.</b> ITEM NAME <b>COOLING LOOP, 3/4", 12V          RAW WATER</b>
DRAWING TOLERANCES APPLY TO PRIMARY DIMENSIONS UNLESS OTHERWISE SPECIFIED X.1: ± 1/16 IN OR 1.5 mm X.2: ± 1/32 IN OR 0.7 mm X.3: ± 0.01 IN OR 0.25 mm X.4: ± 0.005 IN OR 0.125 mm ANGULAR TOLERANCE: ±	 DWN: PBS CKD: - APVD: - DATE: 12SEP16	FOR INTERPRETATION OF DIMENSIONING AND TOLERANCING, SEE ASME Y14.5-2009 MUST CONFORM TO CES 10903	
THIS DOCUMENT AND THE INFORMATION SHOWN THEREON IS CONFIDENTIAL AND PROPRIETARY AND SHALL NOT BE DISCLOSED TO OTHERS IN HARD COPY OR ELECTRONIC FORM, REPRODUCED BY ANY MEANS, OR USED FOR ANY PURPOSE WITHOUT WRITTEN CONSENT OF CUMMINS INC.		CAD SHEET 2 OF 2	ITEM NUMBER <b>A042H725</b>
			REV 4

BILL OF MATERIAL			
ITEM	QTY	DESCRIPTION	PART NUMBER
1	1	SENDER, WATER TEMPERATURE; 1/8" NPT	8862
2	2	REGULATOR, 3/4" NPT, 400 PSI MAX; 25 TO 75 PSI OUT	8890
3	2	STRAINER, 3/4" NPT W/ PLUG;	8891
4	1	GAUGE, PRESSURE, 1/4" NPT; DPG1-2 1/2, 0-100 PSI, (WATTS)	8892
5	2	FTG. STR; MALE NPT TO FEMALE METRIC ORB	12177-4-M14
6	2	VALVE,BALL,3/4NPT; BRASS, LOCKABLE	21504
7	1	CROSS,3/4NPT,STEEL; SCHEDULE 40 PIPE	21519
8	2	VALVE, 3/4" NPT CHECK; VALUE ADDED: CV075	25502
9	2	SEAL, METRIC BONDED; ADAPTALL 9500MM SERIES	26984-14
10	4	BUSHING,3/4" NPT X 1/4" NPT; -	71494
11	3	NIPPLE, BLK, 3/4x6;	71550
12	1	VALVE, SOLENOID, 3/4" NPT, 24VDC;	A042B125
13	1	VALVE, BALL, 1/4" NPT FEMALE;	A042D838
14	2	PLUG, THREADED, M14x1.5; McMASTER-CARR: 5481N25	A060R226
15	1	NIPPLE, 1/4" NPT x 1 1/2"; BLK STEEL	LTL-CPN14112
16	12	NIPPLE, BLK, 3/4x1-1/2;	LTL-CPN34
17	1	ELBOW, BLK, 3/4" NPT, 90 DEG.;	LTL-E3490
18	2	PLUG, 1/2 NPT;	LTL-SCSP12
19	1	REDUCER BUSHING, HEX; 1/4 x 1/8, BLK STEEL	LTL-SRB1418
20	4	TEE, BLACK PIPE; NPT	LTL-ST34

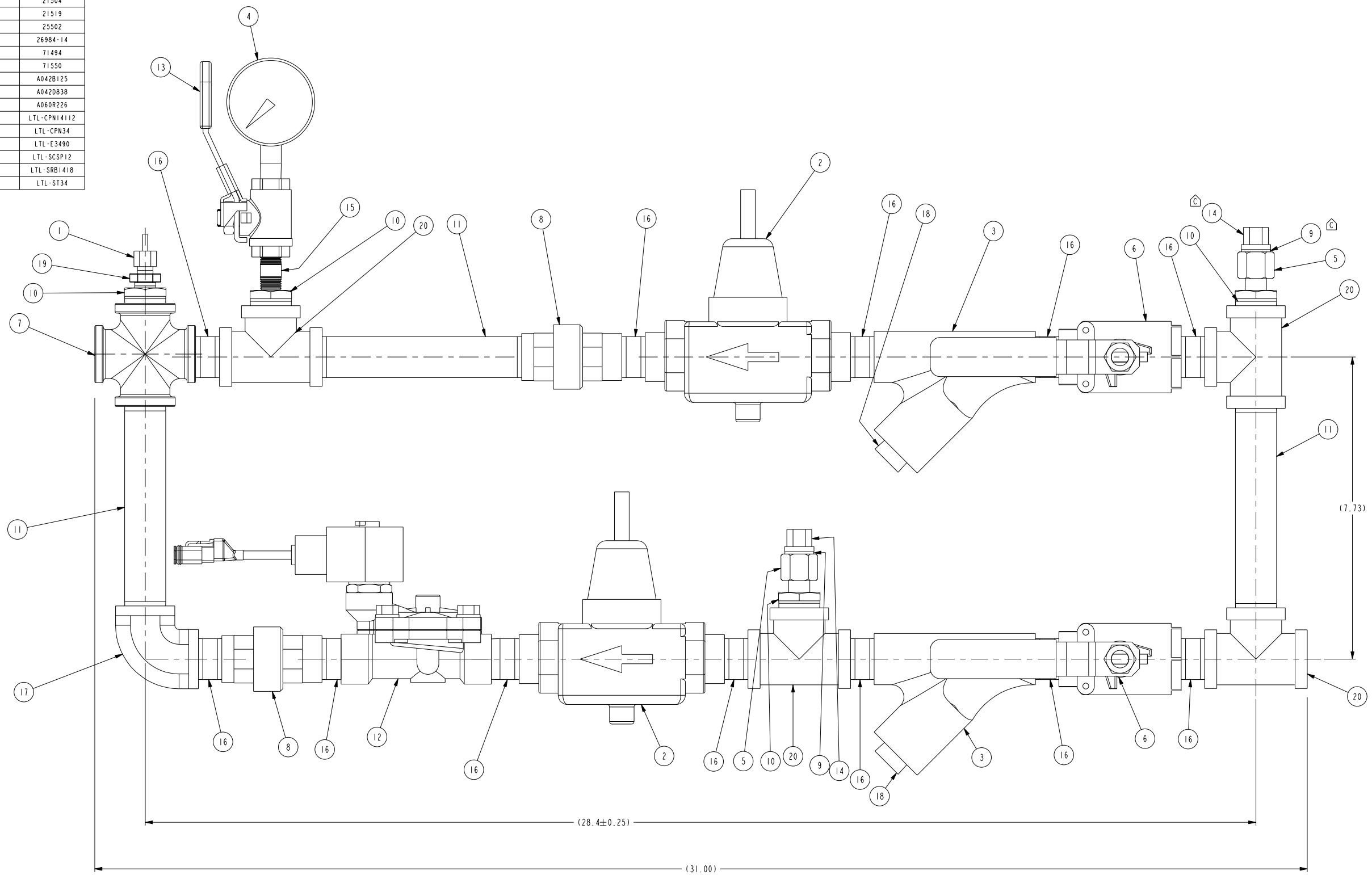

REV	REL NO	REVISION	DWN	CKD	APVD	DATE
-	2016-376	INITIAL RELEASE	PBS			12SEP16
C	2018-360	DELETE: 12210-4; ADD: A060R226, 26984-14 & NOTE	HE392			03JUL18
4	2020-064	ADDED STRAINER SCREEN & O-RING NOTE	RE123	MS707	MS707	30JAN20



- NOTES:
1. MATERIAL: SEE PARTS LIST
  2. REMOVE ALL SHARP EDGES PRIOR TO COATING
  3. LEAK TEST TO 60PSI AND PRESET REGULATORS TO 60PSI
  4. FINISH: COAT PER CUMMINS SPEC ES044 RAL 3001
  5. CAP ALL PORTS PRIOR TO SHIPPING
  6. REPLACEMENT COMPONENTS FOR ITEM 8891:  
REPLACEMENT STRAINER SCREEN P/N: A063Z526  
REPLACEMENT O-RING P/N: A063Z527

DIMENSIONS ARE IN: INCHES [ ] ARE IN: -	DO NOT SCALE PRINT SCALE 0.750	CWI DATA CLASSIFICATION Cummins Confidential		Cummins Inc.	
DRAWING TOLERANCES APPLY TO PRIMARY DIMENSIONS UNLESS OTHERWISE SPECIFIED X.1: ±.1 IN OR 4 mm X.2: ±.1 IN OR 3.7 mm X.3: ±.030 IN OR 0.25 mm X.4: ±.010 IN OR 0.25 mm ANGULAR TOLERANCE: ±	DWN: PBS CKD: - APVD: - DATE: 12SEP16	FOR INTERPRETATION OF DIMENSIONING AND TOLERANCING: SEE ASME Y14.5-2009		ITEM NAME COOLING LOOP, 3/4", 24V RAW WATER	CAD SHEET 1 OF 2
THIS DOCUMENT AND THE INFORMATION SHOWN THEREON IS CONFIDENTIAL AND PROPRIETARY AND SHALL NOT BE DISCLOSED TO OTHERS IN HARD COPY OR ELECTRONIC FORM, REPRODUCED BY ANY MEANS, OR USED FOR ANY PURPOSE WITHOUT WRITTEN CONSENT OF CUMMINS INC.			MUST CONFORM TO CES 10903	REV 4	

8	7	6	5	4	3	2	1
Assembly	Component	Manufacture/pn	Description	Sub-Component	Material	Specification	
A042H726	21504	RUB, S95E45	3/4" 24VDC, Raw Water 3/4" ball valve	body	CW617N	EN12165	
				seat	PTFE		
				ball	CW617N	EN12165	
				end cap	CW617N	EN12165	
				stem	CW617N	EN12164	
				nut	CB4FF	EN10263-2	
				O-ring	FPM		
				handle	DD11	EN10111	
				handle coating	PVC		
				washer	PTFE		
	A042B125	Asco, 8210G003-24V	3/4" NPT 24V solenoid valve	body	brass		
				seals and discs	NBR or PTFE		
				disc holder	PA		
				core tube	305 stainless steel		
				core and plugnut	430F stainless steel		
				springs	302 stainless steel		
				shading coil	copper		
	8862	Datcon, 02022-00	temperature sender	Body	brass		
	8890	Watts, N45BU-M1-3/4"	regulator	body	bronze		
				seat	thermoplastic		
				cage	thermoplastic		
				integral strainer	stainless steel		
				diaphragm	reinforced EPDM		
				valve disc	elastomer		
	8891	Watts, 77S-M1-3/4"	strainer	body	cast iron		
				retainer cap	cast iron	ASTM A-126 Class B	
				screen	304 stainless steel		
	8892	Watts, DPG1-2	pressure gauge	case	ABS polymer		
				window	Kosfil polymer		
				sensing element	copper alloy Bourdon tube		
				welding	tin alloy		
				connection	brass		
	A042D838	RUB, S95B45	1/4" ball valve	body	CW617N	EN12165	
				seat	PTFE		
				ball	CW617N	EN12165	
				end cap	CW617N	EN12165	
				stem	CW617N	EN12164	
				nut	CB4FF	EN10263-2	
				O-ring	FPM		
				handle	DD11	EN10111	
				handle coating	PVC		
				washer	PTFE		
	21519		3/4" cross		black steel	ASTM A53/A733	
	25502	Euroblock, 100002	3/4" check valve	body	brass CW617N	EN12165	
				end connection	brass CW617N	EN12165	
				disc	polyetherimide		
				seat	NBP		
				spring	stainless steel		
	71494		3/4" x 1/4" reducing bushing		black steel	ASTM A53/A733	
	71550		3/4" x 6" nipple		black steel	ASTM A53/A733	
	LTL-CPN14112		1/4" x 1-1/2" nipple		black steel	ASTM A53/A733	
	LTL-CPN34		3/4" x 1-1/2" nipple		black steel	ASTM A53/A733	
	LTL-E3490		3/4", 90° elbow		black steel	ASTM A53/A733	
	LTL-SCSP12		1/2" NPT plug		black steel	ASTM A53/A733	
	LTL-SRB1418		1/4" x 1/8" reducing bushing		black steel	ASTM A53/A733	
	LTL-ST34		3/4" TEE		black steel	ASTM A53/A733	
	12177-4-M14		fig, str, 1/4-18 to M14x1.5		steel, zink plated		

DIMENSIONS ARE IN: INCHES I J ARE IN: -	DO NOT SCALE PRINT SCALE 0.750	CWI DATA CLASSIFICATION Cummins Confidential	 <b>Cummins Inc.</b> ITEM NAME <b>COOLING LOOP, 3/4", 24V          RAW WATER</b>
DRAWING TOLERANCES APPLY TO PRIMARY DIMENSIONS UNLESS OTHERWISE SPECIFIED X.1: ±.1 IN OR 4 mm X.2: ±.1 IN OR 3.7 mm X.3: ±.030 IN OR 0.75 mm X.4: ±.010 IN OR 0.25 mm ANGULAR TOLERANCE: ±	 DATE 12SEP16	FOR INTERPRETATION OF DIMENSIONING AND TOLERANCING, SEE ASME Y14.5-2009	
THIS DOCUMENT AND THE INFORMATION SHOWN THEREON IS CONFIDENTIAL AND PROPRIETARY AND SHALL NOT BE DISCLOSED TO OTHERS IN HARD COPY OR ELECTRONIC FORM, REPRODUCED BY ANY MEANS, OR USED FOR ANY PURPOSE WITHOUT WRITTEN CONSENT OF CUMMINS INC.		MUST CONFORM TO CES 10903	CAD SHEET 2 OF 2 ITEM NUMBER <b>A042H726</b>
			REV 4

BILL OF MATERIAL			
ITEM	QTY	DESCRIPTION	PART NUMBER
1	3	ASSY, ADAPTER, 3/4" ORD x FNPT, W / O-RING	17245
2	1	ASSY, ADAPTER, 1.0" ORD x FNPT, W / O-RING	17246
3	1	DECAL, COOLANT LOOP LABEL, VERTICAL MTG, ENGLISH	A042A453
4	1	BRACKET, COOLING LOOP, CFP5E	A042B375
5	1	SPACER, FEMALE, UNTHREADED ROUND	11585
6	4	CLAMP, PIPE, 3/4", PLASTIC	14926
7	4	CLAMP, WORM, .56-1.06	14990-10
8	4	ELBOW, NAVAL BRONZE, NPT X BARB, 3/4" NPT X 3/4" BARB	15767-12-12
9	1	CLAMP, LOOM, 1.00 ID	26964-16
10	1	HOSE, SILICONE, 3/4IN ID x 6.00IN LONG	A042F073
11	1	HOSE, SILICONE, 3/4IN ID x 36.00IN LONG	A042F073

REV	REL NO	REVISION	DWN	CKD	APVD	DATE
-	2014-363	RELEASED TO PRODUCTION	HE392	-	-	27MAY14
C	2016-102	REPLACED A042F073 WAS 80242GL	LQ629	-	-	05MAY16
D	2019-188	REPLACED 14990-12 W/ 14990-10	NO134	MS707	MS707	19APR19

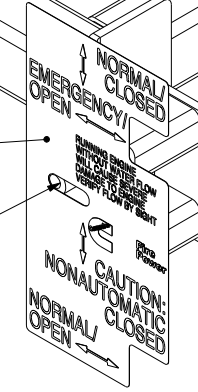
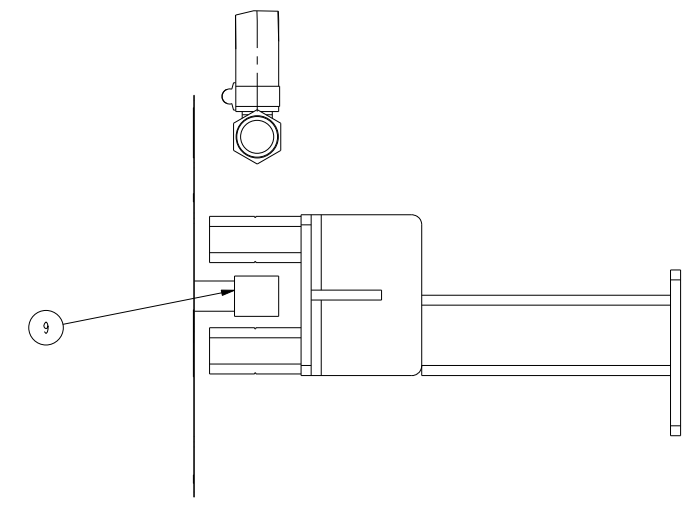
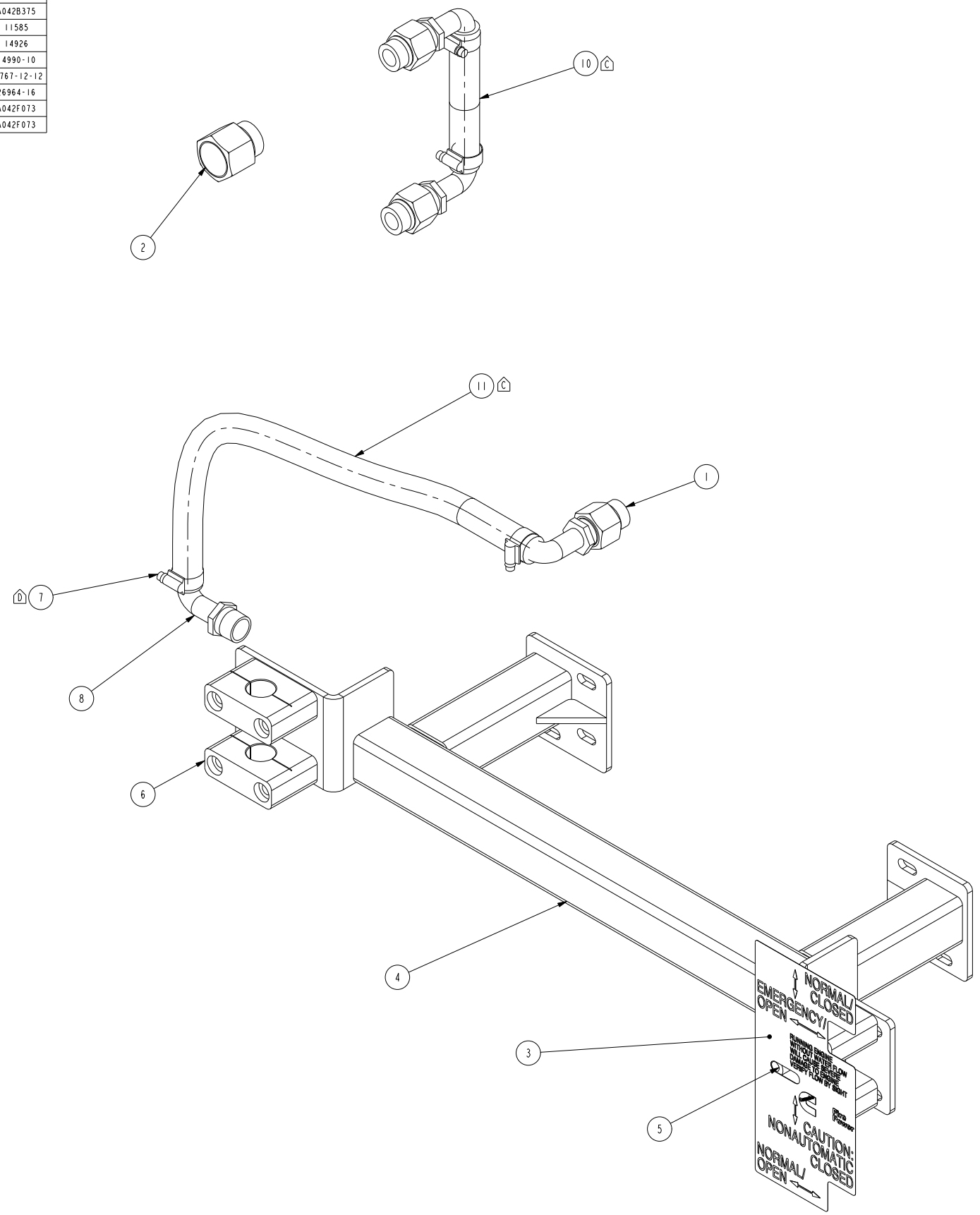

DIMENSIONS ARE IN: INCHES [ ] ARE IN: .	<b>DO NOT SCALE PRINT</b> SCALE 0.438	CMI DATA CLASSIFICATION Cummins Confidential		<b>Cummins Inc.</b>	
				ITEM NAME MISCELLANEOUS PIPING, CFP7E SW LOOP TO RW HEAT EXCHANGERS	
DRAWING TOLERANCES UNLESS OTHERWISE SPECIFIED: X: ± 1 IN OR 4 mm Y: ± 1 IN OR 0.7 mm Z: ± .010 IN OR 0.25 mm X, Y, Z: ± .010 IN OR 0.25 mm ANGULAR TOLERANCES: ± °	FOR INTERPRETATION OF DIMENSIONING AND TOLERANCING, SEE ASME Y14.5-2009	MUST CONFORM TO CES 10903	CAD SHEET 1 OF 1	ITEM NUMBER A042B480	REV D



BILL OF MATERIAL			
ITEM	QTY	DESCRIPTION	PART NUMBER
1	1	SENDER, WATER TEMPERATURE; 1/8" NPT	8862
2	1	GAUGE, 0-100 PSI; 1/4" NPT STN STL	13113
3	1	REGULATOR/STRAINER, 3/4" NPT; SEA WATER COMPATIBLE	13703
4	1	REGULATOR/STRAINER, 3/4" NPT; SEA WATER COMPATIBLE	13703
5	4	TEE, MARINE GRADE; 3/4" NPT	15755-12
6	1	ELBOW, MARINE GRADE; 3/4" NPT	15756-12
7	4	BUSHING, MARINE GRADE; 3/4" x 1/4"	15758-12-4
8	1	BUSHING, MARINE GRADE; 1/4" x 1/8"	15758-4-2
9	1	VALVE, BALL, 1/4" NPT.; APOLLO 77-100 (MARINE)	15759-04
10	1	NIPPLE, NAVAL BRONZE, 1/4" X CLOSE;	15760
11	6	NIPPLE, MARINE GRADE, 3/4" X 1-3/8";	15761
12	2	NIPPLE, MARINE GRADE, 3/4" X 2-1/2";	15762
13	4	NIPPLE, MARINE GRADE, 3/4" X 6";	15764
14	2	CHECK VALVE, MARINE GRADE, 3/4" NPT;	15768-12
15	2	VALVE, BALL, 3/4" NPT; SEA WATER COMPATIBLE, LOCKABLE	21434
16	1	CROSS, 3/4, NVL-BRNZ; SCHEDULE 40 PIPE	21436
17	2	SEAL, METRIC BONDED; ADAPTALL 9500MM SERIES	26984-14
18	2	ADAPTER, 1/4 NPT TO M14-1.5; SEA WATER COMPATIBLE	A042H751
19	2	PLUG, THREADED, M14x1.5; McMASTER-CARR: 5481X25	A060R226

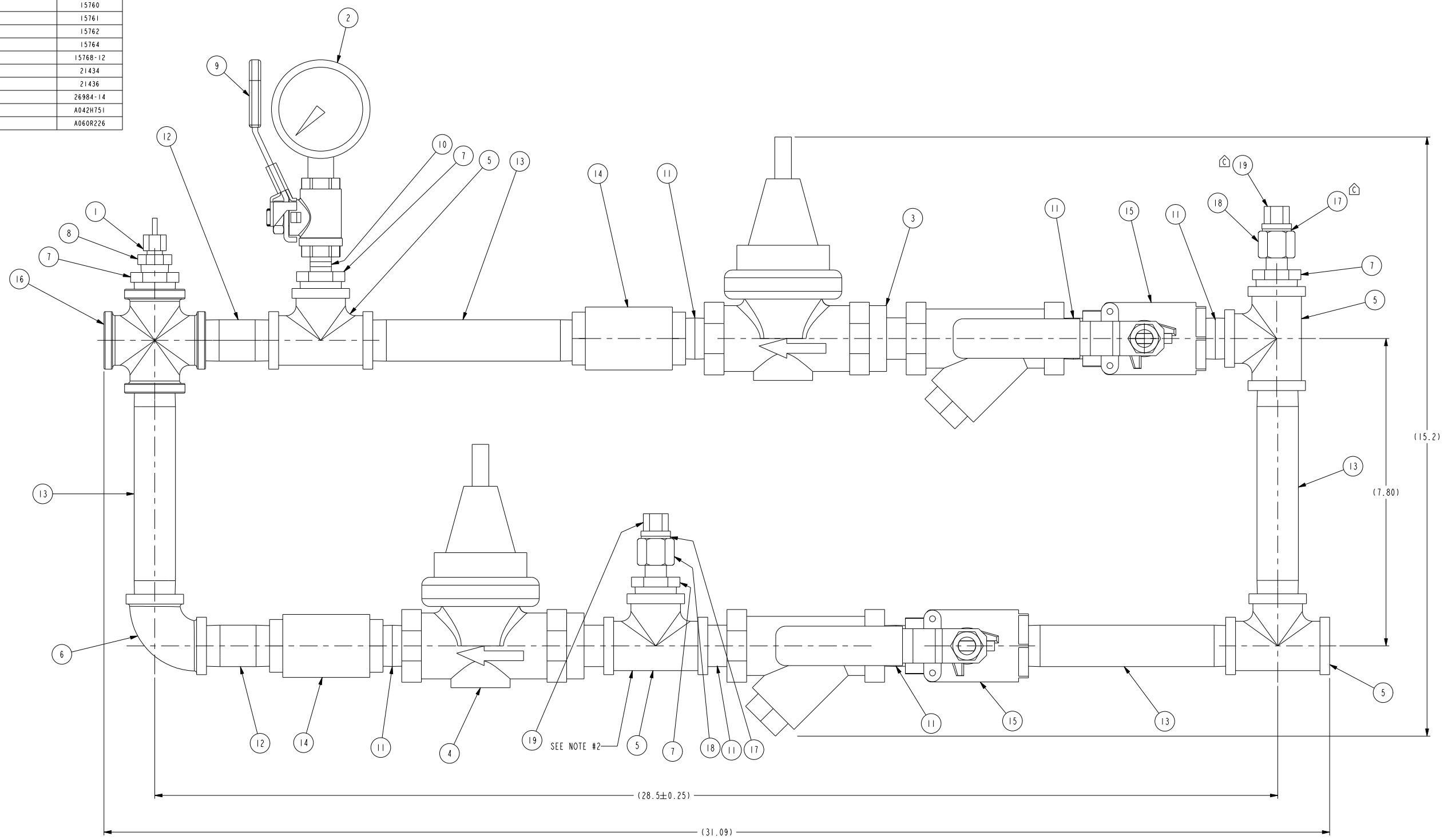

REV	REL NO	REVISION	DWN	CKD	APVD	DATE
-	2016-376	INITIAL RELEASE	PBS			12SEP16
C	2018-360	DELETE: 12210-4; ADD: A060R226, 26984-14 & NOTE	HE392			03JUL18
4	2020-064	ADDED STRAINER SCREEN & O-RING NOTE; CHANGED 13703 TO QTY (2)	RE123	MS707	MS707	30JAN20



- NOTES:
- MATERIAL: SEE PARTS LIST
  - ITEM 13703 IS RECEIVED AS UNASSEMBLED KIT. AT ASSEMBLY ADD ITEMS SHOWN
  - REMOVE ALL SHARP EDGES PRIOR TO COATING
  - LEAK TEST TO 60PSI AND PRESET REGULATORS TO 60PSI
  - FINISH: COAT PER CUMMINS SPEC ES044 RAL 3001
  - CAP ALL PORTS PRIOR TO SHIPPING
  - REPLACEMENT COMPONENTS FOR ITEM 13703:  
REPLACEMENT STRAINER SCREEN P/N: A063Z530  
REPLACEMENT O-RING P/N: A063Z531

DIMENSIONS ARE IN: INCHES I J ARE IN: - DRAWING TOLERANCES APPLY TO PRIMARY DIMENSIONS UNLESS OTHERWISE SPECIFIED X.1: ± 1 IN OR 4 mm X.2: ± 1 IN OR 3.7 mm X.3: ± .030 IN OR 0.25 mm X.4: ± .010 IN OR 0.25 mm ANGULAR TOLERANCE: ±	<b>DO NOT SCALE PRINT</b> SCALE 0.750 	CMI DATA CLASSIFICATION Cummins Confidential DWN: PBS CKD: - APVD: - DATE: 12SEP16	<b>Cummins Inc.</b> ITEM NAME <b>COOLING LOOP, 3/4", VERT          SEA WATER COMPATIBLE</b>
THIS DOCUMENT AND THE INFORMATION SHOWN THEREON IS CONFIDENTIAL AND PROPRIETARY AND SHALL NOT BE DISCLOSED TO OTHERS IN HARD COPY OR ELECTRONIC FORM. REPRODUCED BY ANY MEANS, OR USED FOR ANY PURPOSE WITHOUT WRITTEN CONSENT OF CUMMINS INC.	FOR INTERPRETATION OF DIMENSIONING AND TOLERANCING SEE ASME Y14.5-2009	MUST CONFORM TO CES 10903	CAD SHEET 1 OF 2 ITEM NUMBER <b>A042H727</b> REV <b>4</b>

8	7	6	5	4	3	2	1
Assembly	Component	Manufacture/pn	Description	Sub-Component	Material	Specification	
A042H727	21434	Apollo, 75-104-01	3/4" Vertical, Sea Water 3/4" ball valve				
				lever and grip	steel, zinc plated w/vinyl		
				stem packing	MPTFE		
				stem bearing	RPTFE		
				ball	chrome plated	ASTM B16	
				seal	RPTFE		
				retainer		ASTM B16	
				gland nut		ASTM B16	
				stem		ASTM B16	
				lever nut	steel, zinc plated		
				body seal	PTFE		
				body		ASTM B524-C84400	
	8862	Datcon 02022-00	temperature sender	body	brass		
	13113	Grainger, 4RY95	pressure gauge				
				case	stainless steel		
				socket	316 stainless steel		
				tube	316 stainless steel		
				lens	polycarbonate		
				ring	316 stainless steel		
	13703	Wilkins, 500YSBRHLRSW	3/4" regulator/strainer				
				body	cast bronze	ASTM B584	
				access covers	cast bronze	ASTM B584	
					brass	ASTM B16	
				fasteners	300 series stainless steel		
				stem & plunger	cast bronze	ASTM B584	
					brass	ASTM B16	
				elastomers	Buna Nitrile	FDA approved	
					EPDM	FDA approved	
				cap gaskets	natural vulcanized fibre		
					Acetal (Delrin 500)	NSF Listed	
				springs	oil tempered wire	ASTM A229	
				strainer screen	300 series stainless steel		
				seal	300 series stainless steel		
	15755-12		3/4" tee		Copper Alloy	ASTM B62-09	
	15756-12		3/4" elbow		Copper Alloy	ASTM B62-09	
	15758-12-4		3/4" x 1/4" reducing bushing		Copper Alloy	ASTM B62-09	
	15758-4-2		1/4" x 1/8" reducing bushing		Copper Alloy	ASTM B62-09	
	15759-04	Apollo, 77-101-01	1/4" ball valve				
				lever and grip	steel, zinc plated w/vinyl		
				stem packing	MPTFE		
				stem bearing	RPTFE		
				ball	chrome plated	ASTM B16	
				seal	RPTFE		
				retainer		ASTM B16	
				gland nut		ASTM B16	
				stem		ASTM B16	
				lever nut	steel, zinc plated		
				body seal	PTFE		
				body		ASTM B524-C84400	
	15760		1/4" close nipple		Copper Alloy	ASTM B62-09	
	15761		3/4" x 1-3/8" nipple		Copper Alloy	ASTM B62-09	
	15762		3/4" x 2-1/2" nipple		Copper Alloy	ASTM B62-09	
	15764		3/4" x 6" nipple		Copper Alloy	ASTM B62-09	
	15768-12	Watts, series 600	3/4" check valve		Copper Alloy	ASTM B62-09	
				body	bronze		
				guide bushing	stainless steel		
				spring	stainless steel		
				check	brass		
				seal	PTFE		
				O-ring	Nitrile		
				adapter	brass		
	21436		3/4" cross		Copper Alloy	ASTM B62-09	
	A042H751		adapter 1/4 NPT to M14-1.5		Copper Alloy	ASTM B62-09	

DIMENSIONS ARE IN: INCHES [ ] ARE IN: -	DO NOT SCALE PRINT SCALE 0.750	CWI DATA CLASSIFICATION Cummins Confidential	 <b>Cummins Inc.</b> ITEM NAME <b>COOLING LOOP, 3/4", VERT          SEA WATER COMPATIBLE</b>
DRAWING TOLERANCES APPLY TO PRIMARY DIMENSIONS UNLESS OTHERWISE SPECIFIED X.1: ± 1 IN OR 4 mm X.2: ± 1 IN OR 3.7 mm X.3: ± .030 IN OR 0.75 mm X.4: ± .010 IN OR 0.25 mm ANGULAR TOLERANCE: ±	 DATE 12SEP16 FOR INTERPRETATION OF DIMENSIONING AND TOLERANCING, SEE ASME Y14.5-2009	MUST CONFORM TO CES 10903 2 OF 2 CAD SHEET ITEM NUMBER <b>A042H727</b>	
<small>THIS DOCUMENT AND THE INFORMATION SHOWN THEREON IS CONFIDENTIAL AND PROPRIETARY AND SHALL NOT BE DISCLOSED TO OTHERS IN HARD COPY OR ELECTRONIC FORM, REPRODUCED BY ANY MEANS, OR USED FOR ANY PURPOSE WITHOUT WRITTEN CONSENT OF CUMMINS INC.</small>		REV 4	

BILL OF MATERIAL			
ITEM	QTY	DESCRIPTION	PART NUMBER
1	1	SENDER, WATER TEMPERATURE; 1/8" NPT	8862
2	1	GAUGE, 0-100 PSI; 1/4" NPT STN STL	13113
3	1	REGULATOR/STRAINER, 3/4" NPT; SEA WATER COMPATIBLE	13703
4	1	REGULATOR/STRAINER, 3/4" NPT; SEA WATER COMPATIBLE	13703
5	1	VALVE, SOLENOID, 3/4" NPT, 12VDC; SEA WATER COMPATIBLE	15738
6	4	TEE, MARINE GRADE; 3/4" NPT	15755-12
7	1	ELBOW, MARINE GRADE; 3/4" NPT	15756-12
8	4	BUSHING, MARINE GRADE; 3/4" x 1/4"	15758-12-4
9	1	BUSHING, MARINE GRADE; 1/4" x 1/8"	15758-4-2
10	1	VALVE, BALL, 1/4" NPT.; APOLLO 77-100 (MARINE)	15759-04
11	1	NIPPLE, NAVAL BRONZE, 1/4" X CLOSE;	15760
12	7	NIPPLE, MARINE GRADE, 3/4" X 1-3/8";	15761
13	3	NIPPLE, MARINE GRADE, 3/4" X 2-1/2";	15762
14	3	NIPPLE, MARINE GRADE, 3/4" X 6";	15764
15	2	CHECK VALVE, MARINE GRADE, 3/4" NPT;	15768-12
16	2	VALVE, BALL, 3/4" NPT; SEA WATER COMPATIBLE, LOCKABLE	21434
17	1	CROSS, 3/4, NVL-BRNZ; SCHEDULE 40 PIPE	21436
18	2	SEAL, METRIC BONDED; ADAPTALL 9500MM SERIES	26984-14
19	2	ADAPTER, 1/4 NPT TO M14-1.5; SEA WATER COMPATIBLE	A042H751
20	2	PLUG, THREADED, M14x1.5; McMASTER-CARR: 5481X25	A060R226

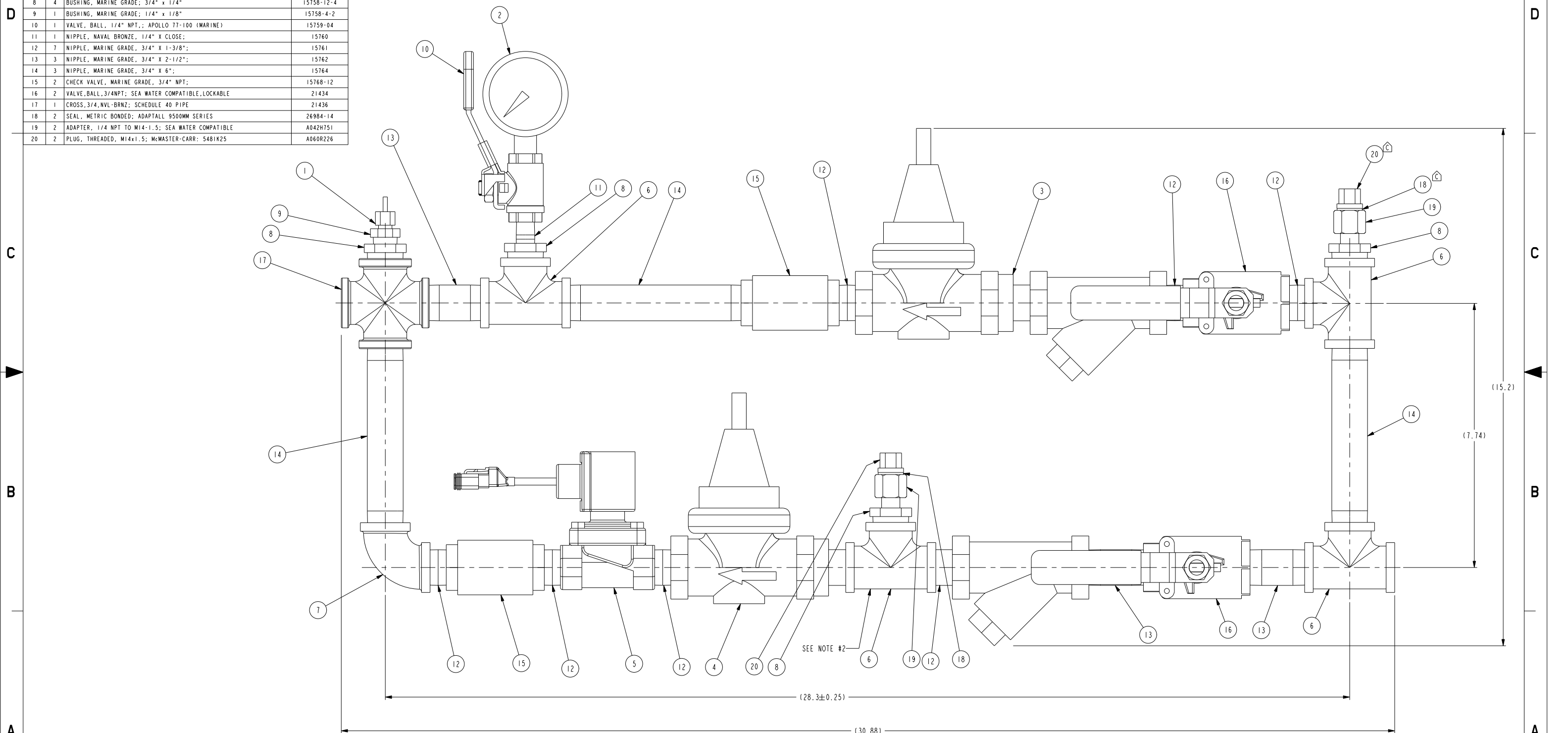

REV	REL NO	REVISION	DWN	CKD	APVD	DATE
-	2016-376	INITIAL RELEASE	PBS			12SEP16
C	2018-360	DELETE: 12210-4; ADD: A060R226, 26984-14 & NOTE	HE392			03JUL18
4	2020-064	ADDED STRAINER SCREEN & O-RING NOTE; CHANGED 13703 TO (QTY 2)	RE123	MS707	MS707	30JAN20



- NOTES:
1. MATERIAL: SEE PARTS LIST
  2. ITEM 13703 IS RECEIVED AS UNASSEMBLED KIT. AT ASSEMBLY ADD ITEMS SHOWN
  3. REMOVE ALL SHARP EDGES PRIOR TO COATING
  4. LEAK TEST TO 60PSI AND PRESET REGULATORS TO 60PSI
  5. FINISH: COAT PER CUMMINS SPEC E5044 RAL 3001
  6. CAP ALL PORTS PRIOR TO SHIPPING
  7. REPLACEMENT COMPONENTS FOR 13703:  
REPLACEMENT STRAINER SCREEN P/N: A063Z530  
REPLACEMENT O-RING P/N: A063Z531

DIMENSIONS ARE IN: INCHES 1: ARE IN: -	DO NOT SCALE PRINT SCALE 0.750	CMI DATA CLASSIFICATION Cummins Confidential		Cummins Inc.	
DRAWING TOLERANCES APPLY TO PRIMARY DIMENSIONS UNLESS OTHERWISE SPECIFIED X.1: ± 1 IN OR 4 mm X.2: ± 1 IN OR 3.7 mm X.3: ± .030 IN OR 0.75 mm X.4: ± .010 IN OR 0.25 mm ANGULAR TOLERANCE: ±		DWN: PBS CKD: - APVD: - DATE: 12SEP16		ITEM NAME COOLING LOOP, 3/4", 12V SEA WATER COMPATIBLE	CAD SHEET 1 OF 2
<small>THIS DOCUMENT AND THE INFORMATION SHOWN THEREON IS CONFIDENTIAL AND PROPRIETARY AND SHALL NOT BE DISCLOSED TO OTHERS IN HARD COPY OR ELECTRONIC FORM, REPRODUCED BY ANY MEANS, OR USED FOR ANY PURPOSE WITHOUT WRITTEN CONSENT OF CUMMINS INC.</small>			<small>FOR INTERPRETATION OF DIMENSIONING AND TOLERANCING, SEE ASME Y14.5-2009</small>		<small>MUST CONFORM TO CES 10903</small>

8	7	6	5	4	3	2	1
Assembly	Component	Manufacture/pn	Description	Sub-Component	Material	Specification	
A042H728			3/4" 12VDC, Sea Water				
	15738	GC Valves, S211GF15J7EG5	3/4" NPT 12V solenoid valve	valve body/bonnet	316 stainless steel	ASTM A351 CF8M	
				plunger tube -tub head	430FR	ASTM A838 alloy 2	
				tube head shading ring	commercial grade silver	ASTM B742-90	
				plunger tube	304 stainless steel	ASTM A269	
				valve plunger	430FR	ASTM A838 alloy 2	
				plunger spring	302 stainless steel	ASTM A313-08	
				diaphragm pilot orifice	303 stainless steel	ASTM A8582	
				diaphragm back plate/dish plate	304 stainless steel	ASTM A276-13	
	21434	Apollo, 75-104-01	3/4" ball valve	lever and grip	steel, zinc plated w/vinyl		
				stem packing	MPTFE		
				stem bearing	RPTFE		
				ball	chrome plated	ASTM B16	
				seat	RPTFE		
				retainer		ASTM B16	
				gland nut		ASTM B16	
				stem		ASTM B16	
				lever nut	steel, zinc plated		
				body seal	PTFE		
				body		ASTM B524-C84400	
	8862	Datcon 02022-00	temperature sender	Body	brass		
	13113	Grainger, 4RY95	pressure gauge	case	stainless steel		
				socket	316 stainless steel		
				tube	316 stainless steel		
				lens	polycarbonate		
				ring	316 stainless steel		
	13703	Wilkins, 500YSBRHLRSW	3/4" regulator/strainer	body	cast bronze	ASTM B584	
				access covers	cast bronze	ASTM B584	
					brass	ASTM B16	
				fasteners	300 series stainless steel		
				stem & plunger	cast bronze	ASTM B584	
					brass	ASTM B16	
				elastomers	Buna Nitrile	FDA approved	
					EPDM	FDA approved	
				cap gaskets	natural vulcanized fibre		
					Acetal (Delrin 500)	NSF Listed	
				springs	oil tempered wire	ASTM A229	
				strainer screen	300 series stainless steel		
				seat	300 series stainless steel		
	15755-12		3/4" tee		Copper Alloy	ASTM B62-09	
	15756-12		3/4" elbow		Copper Alloy	ASTM B62-09	
	15758-12-4		3/4" x 1/4" reducing bushing		Copper Alloy	ASTM B62-09	
	15758-4-2		1/4" x 1/8" reducing bushing		Copper Alloy	ASTM B62-09	
	15759-04	Apollo, 77-101-01	1/4" ball valve	lever and grip	steel, zinc plated w/vinyl		
				stem packing	MPTFE		
				stem bearing	RPTFE		
				ball	chrome plated	ASTM B16	
				seat	RPTFE		
				retainer		ASTM B16	
				gland nut		ASTM B16	
				stem		ASTM B16	
				lever nut	steel, zinc plated		
				body seal	PTFE		
				body		ASTM B524-C84400	
	15760		1/4" close nipple		Copper Alloy	ASTM B62-09	
	15761		3/4" x 1-3/8" nipple		Copper Alloy	ASTM B62-09	
	15762		3/4" x 2-1/2" nipple		Copper Alloy	ASTM B62-09	
	15764		3/4" x 6" nipple		Copper Alloy	ASTM B62-09	
	15768-12	Watts, series 600	3/4" check valve	body	bronze		
				guide bushing	stainless steel		
				spring	stainless steel		
				check	brass		
				seat	PTFE		
				O-ring	Nitrile		
				adaptor	brass		
	21436		3/4" cross		Copper Alloy	ASTM B62-09	
A042H751			adaptor 1/4 NPT to M14-1.5		Copper Alloy	ASTM B62-09	

DIMENSIONS ARE IN: INCHES [ ] ARE IN: -	DO NOT SCALE PRINT SCALE 0.750	CWI DATA CLASSIFICATION Cummins Confidential	 <b>Cummins Inc.</b> ITEM NAME COOLING LOOP, 3/4", 12V SEA WATER COMPATIBLE
DRAWING TOLERANCES APPLY TO PRIMARY DIMENSIONS UNLESS OTHERWISE SPECIFIED X.1: ±.1 IN OR 4 mm X.2: ±.1 IN OR 3.7 mm X.3: ±.030 IN OR 0.75 mm X.4: ±.010 IN OR 0.25 mm ANGULAR TOLERANCE: ±		DWN - PBS CKD - APVD - DATE 12SEP16	
THIS DOCUMENT AND THE INFORMATION SHOWN THEREON IS CONFIDENTIAL AND PROPRIETARY AND SHALL NOT BE DISCLOSED TO OTHERS IN HARD COPY OR ELECTRONIC FORM, REPRODUCED BY ANY MEANS, OR USED FOR ANY PURPOSE WITHOUT WRITTEN CONSENT OF CUMMINS INC.		FOR INTERPRETATION OF DIMENSIONS AND TOLERANCING, SEE ASME Y14.5-2009	MUST CONFORM TO CES 10903 2 OF 2 CAD SHEET ITEM NUMBER A042H728 REV 4

BILL OF MATERIAL			
ITEM	QTY	DESCRIPTION	PART NUMBER
1	1	SENDER, WATER TEMPERATURE; 1/8" NPT	8862
2	1	GAUGE, 0-100 PSI; 1/4" NPT STN STL	13113
3	1	REGULATOR/STRAINER, 3/4" NPT; SEA WATER COMPATIBLE	13703
4	1	REGULATOR/STRAINER, 3/4" NPT; SEA WATER COMPATIBLE	13703
5	1	VALVE, SOLENOID, 3/4" NPT, 24VDC; SEA WATER COMPATIBLE	15739
6	4	TEE, MARINE GRADE; 3/4" NPT	15755-12
7	1	ELBOW, MARINE GRADE; 3/4" NPT	15756-12
8	4	BUSHING, MARINE GRADE; 3/4" x 1/4"	15758-12-4
9	1	BUSHING, MARINE GRADE; 1/4" x 1/8"	15758-4-2
10	1	VALVE, BALL, 1/4" NPT.; APOLLO 77-100 (MARINE)	15759-04
11	1	NIPPLE, NAVAL BRONZE, 1/4" X CLOSE;	15760
12	6	NIPPLE, MARINE GRADE, 3/4" X 1-3/8";	15761
13	3	NIPPLE, MARINE GRADE, 3/4" X 2-1/2";	15762
14	3	NIPPLE, MARINE GRADE, 3/4" X 6";	15764
15	2	CHECK VALVE, MARINE GRADE, 3/4" NPT;	15768-12
16	2	VALVE, BALL, 3/4"NPT; SEA WATER COMPATIBLE, LOCKABLE	21434
17	1	CROSS, 3/4, NVL-BRNZ; SCHEDULE 40 PIPE	21436
18	2	SEAL, METRIC BONDED; ADAPTALL 950MM SERIES	26984-14
19	2	ADAPTER, 1/4 NPT TO M14-1.5; SEA WATER COMPATIBLE	A042H751
20	2	PLUG, THREADED, M14x1.5; McMASTER-CARR: 5481X25	A060R226

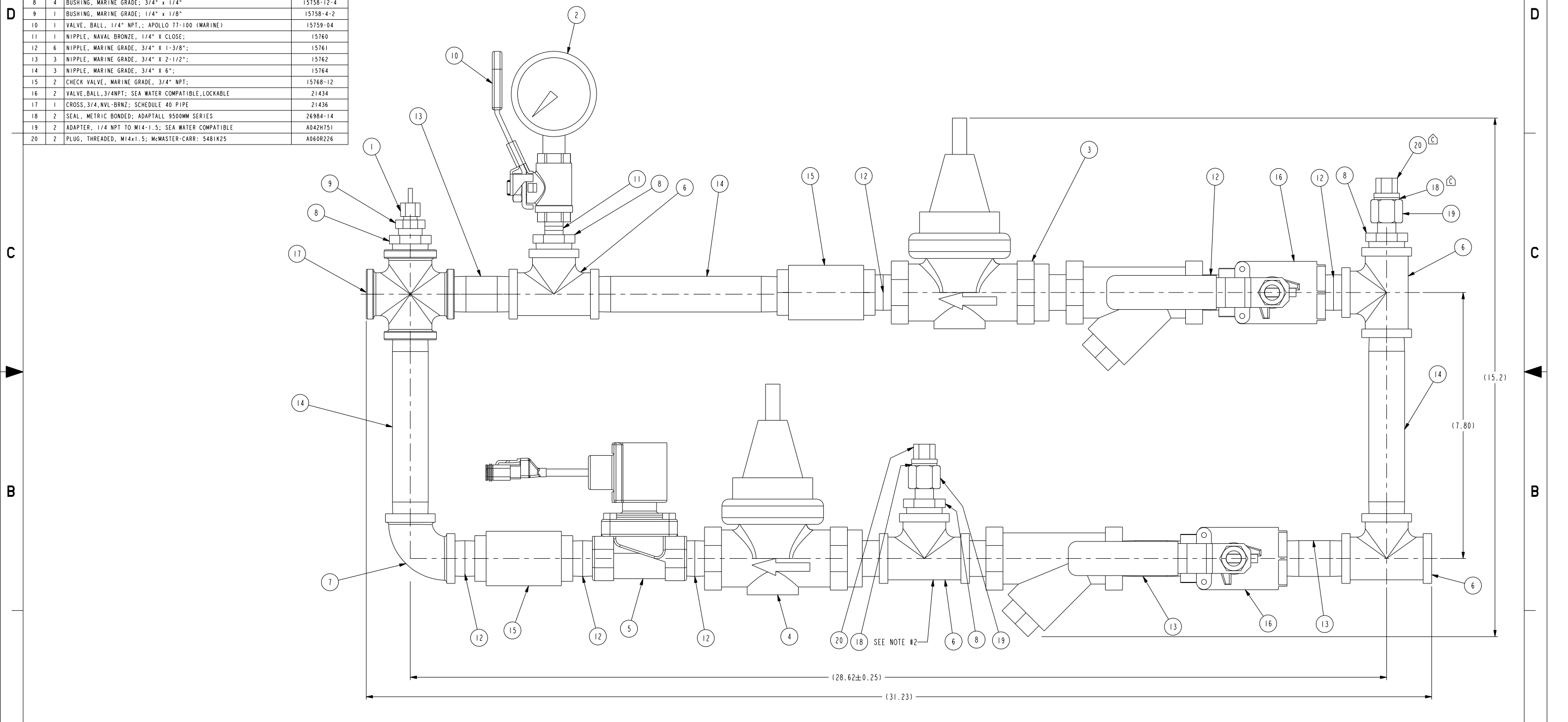

REV	REL NO	REVISION	DWN	CKD	APVD	DATE
-	2016-376	INITIAL RELEASE	PBS			12SEP16
C	2018-360	DELETE: 12210-4; ADD: A060R226, 26984-14 & NOTE	HE392			03JUL18
4	2020-064	ADD STRAINER SCREEN & O-RING NOTE; CHANGED 13703 TO QTY (2)	RE123	MS707	MS707	30JAN20



- NOTES:
1. MATERIAL: SEE PARTS LIST
  2. ITEM 13703 IS RECEIVED AS AN UNASSEMBLED KIT. AT ASSEMBLY ADD ITEMS SHOWN
  3. REMOVE ALL SHARP EDGES PRIOR TO COATING
  4. LEAK TEST TO 60PSI AND PRESET REGULATORS TO 60PSI
  5. FINISH: COAT PER CUMMINS SPEC ES044 RAL 3001
  6. CAP ALL PORTS PRIOR TO SHIPPING
  7. REPLACEMENT COMPONENTS FOR ITEM 13703:  
REPLACEMENT STRAINER SCREEN P/N: A063Z530  
REPLACEMENT O-RING P/N: A063Z531

DIMENSIONS ARE IN: INCHES [ ] ARE IN: -	DO NOT SCALE PRINT SCALE 0.750	CMI DATA CLASSIFICATION Cummins Confidential		<b>Cummins Inc.</b> ITEM NAME <b>COOLING LOOP, 3/4", 24V          SEA WATER COMPATIBLE</b>	
<small>DRAWING TOLERANCES APPLY TO PRIMARY DIMENSIONS UNLESS OTHERWISE SPECIFIED</small> X.1: ± 1/16 IN OR 1.6 mm X.2: ± 1/32 IN OR 0.8 mm X.3: ± 0.01 IN OR 0.25 mm X.4: ± 0.005 IN OR 0.125 mm ANGULAR TOLERANCE: ±	<small>FOR INTERPRETATION OF DIMENSIONING AND TOLERANCING, SEE ASME Y14.5-2009</small>	DWN: PBS CKD: - APVD: - DATE: 12SEP16		MUST CONFORM TO CES 10903	CAD SHEET 1 OF 2

8	7	6	5	4	3	2	1
Assembly	Component	Manufacture/pn	Description	Sub-Component	Material	Specification	
A042H729			3/4" 24VDC, Sea Water				
	15739	GC Valves, S211GF16J7EG5	3/4" NPT 24V solenoid valve	valve body/bonnet	316 stainless steel	ASTM A351 CF8M	
				plunger tube -lub head	430FR	ASTM A838 alloy 2	
				tube head shading ring	commercial grade silver	ASTM B742-90	
				plunger tube	304 stainless steel	ASTM A269	
				valve plunger	430FR	ASTM A838 alloy 2	
				plunger spring	302 stainless steel	ASTM 313-08	
				diaphragm pilot orifice	303 stainless steel	ASTM A8582	
				diaphragm back plate/dish plate	304 stainless steel	ASTM A276-13	
	21434	Apollo, 75-104-01	3/4" ball valve	lever and grip	steel, zinc plated w/vinyl		
				stem packing	MPTFE		
				stem bearing	RPTFE		
				ball	chrome plated	ASTM B16	
				seat	RPTFE		
				retainer		ASTM B16	
				gland nut		ASTM B16	
				stem		ASTM B16	
				lever nut	steel, zinc plated		
				body seal	PTFE		
				body		ASTM B524-C84400	
	8862	Datcon 02022-00	temperature sender	Body	brass		
	13113	Grainger, 4RY95	pressure gauge	case	stainless steel		
				socket	316 stainless steel		
				tube	316 stainless steel		
				lens	polycarbonate		
				ring	316 stainless steel		
	13703	Wilkins, 500YSBRHLRSW	3/4" regulator/strainer	body	cast bronze	ASTM B584	
				access covers	cast bronze	ASTM B584	
					brass	ASTM B16	
				fasteners	300 series stainless steel		
				stem & plunger	cast bronze	ASTM B584	
					brass	ASTM B16	
				elastomers	Buna Nitrile	FDA approved	
					EPDM	FDA approved	
				cap gaskets	natural vulcanized fibre		
					Acetal (Delrin 500)	NSF Listed	
				springs	oil tempered wire	ASTM A229	
				strainer screen	300 series stainless steel		
				seat	300 series stainless steel		
	15755-12		3/4" tee		Copper Alloy	ASTM B62-09	
	15756-12		3/4" elbow		Copper Alloy	ASTM B62-09	
	15758-12-4		3/4" x 1/4" reducing bushing		Copper Alloy	ASTM B62-09	
	15758-4-2		1/4" x 1/8" reducing bushing		Copper Alloy	ASTM B62-09	
	15759-04	Apollo, 77-101-01	1/4" ball valve		Copper Alloy	ASTM B62-09	
				lever and grip	steel, zinc plated w/vinyl		
				stem packing	MPTFE		
				stem bearing	RPTFE		
				ball	chrome plated	ASTM B16	
				seat	RPTFE		
				retainer		ASTM B16	
				gland nut		ASTM B16	
				stem		ASTM B16	
				lever nut	steel, zinc plated		
				body seal	PTFE		
				body		ASTM B524-C84400	
	15760		1/4" close nipple		Copper Alloy	ASTM B62-09	
	15761		3/4" x 1-3/8" nipple		Copper Alloy	ASTM B62-09	
	15762		3/4" x 2-1/2" nipple		Copper Alloy	ASTM B62-09	
	15764		3/4" x 6" nipple		Copper Alloy	ASTM B62-09	
	15768-12	Watts, series 600	3/4" check valve	body	bronze		
				guide bushing	stainless steel		
				spring	stainless steel		
				check	brass		
				seat	PTFE		
				O-ring	Nitrile		
				adapter	brass		
	21436		3/4" cross		Copper Alloy	ASTM B62-09	
A042H751			adapter 1/4 NPT to M14-1.5		Copper Alloy	ASTM B62-09	

DIMENSIONS ARE IN: INCHES [ ] ARE IN: -	DO NOT SCALE PRINT SCALE 0.750	CWI DATA CLASSIFICATION Cummins Confidential	 <b>Cummins Inc.</b> ITEM NAME <b>COOLING LOOP, 3/4", 24V SEA WATER COMPATIBLE</b>
DRAWING TOLERANCES APPLY TO PRIMARY DIMENSIONS UNLESS OTHERWISE SPECIFIED X.1: ± 1/16 IN OR 1.6 mm X.2: ± 1/32 IN OR 0.7 mm X.3: ± 0.01 IN OR 0.25 mm X.4: ± 0.005 IN OR 0.125 mm ANGULAR TOLERANCE: ±	 DWG: PBS CKD: - APVD: - DATE: 12SEP16	FOR INTERPRETATION OF DIMENSIONING AND TOLERANCING, SEE ASME Y14.5-2009 MUST CONFORM TO CES 10903	
THIS DOCUMENT AND THE INFORMATION SHOWN THEREON IS CONFIDENTIAL AND PROPRIETARY AND SHALL NOT BE DISCLOSED TO OTHERS IN HARD COPY OR ELECTRONIC FORM, REPRODUCED BY ANY MEANS, OR USED FOR ANY PURPOSE WITHOUT WRITTEN CONSENT OF CUMMINS INC.		CAD SHEET 2 OF 2	ITEM NUMBER <b>A042H729</b>
		REV 4	

TYPICAL GUARDING FASTENERS  
SCALE 0.500

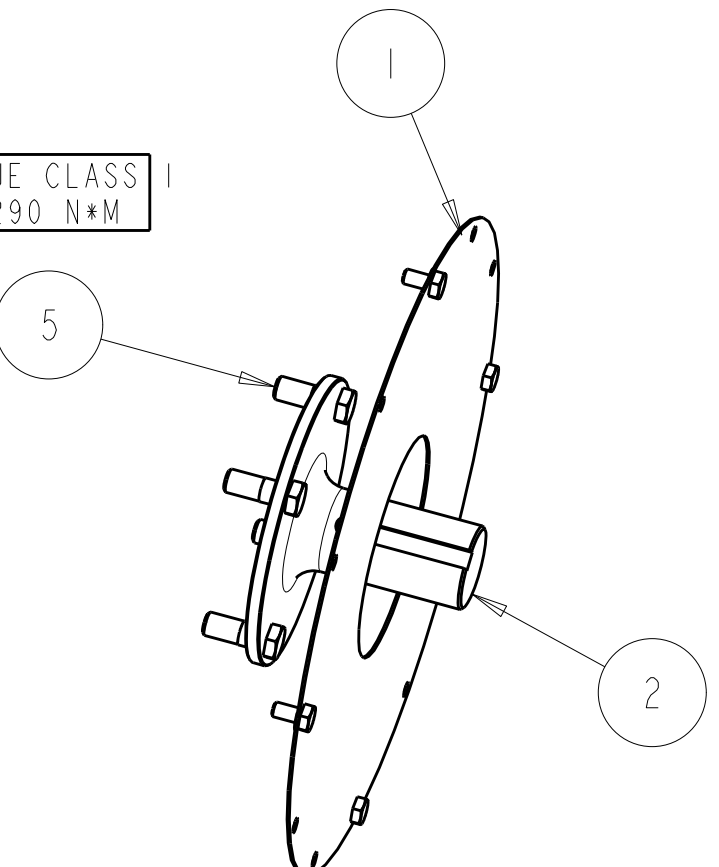
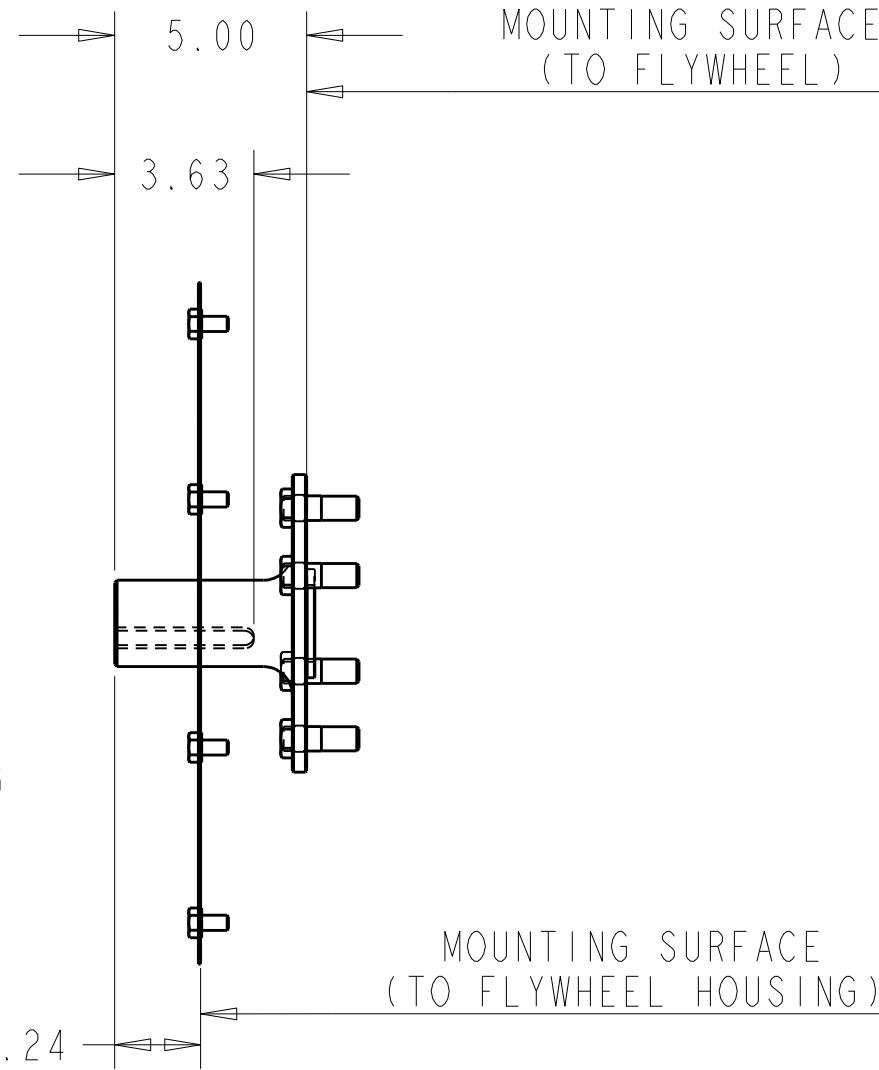
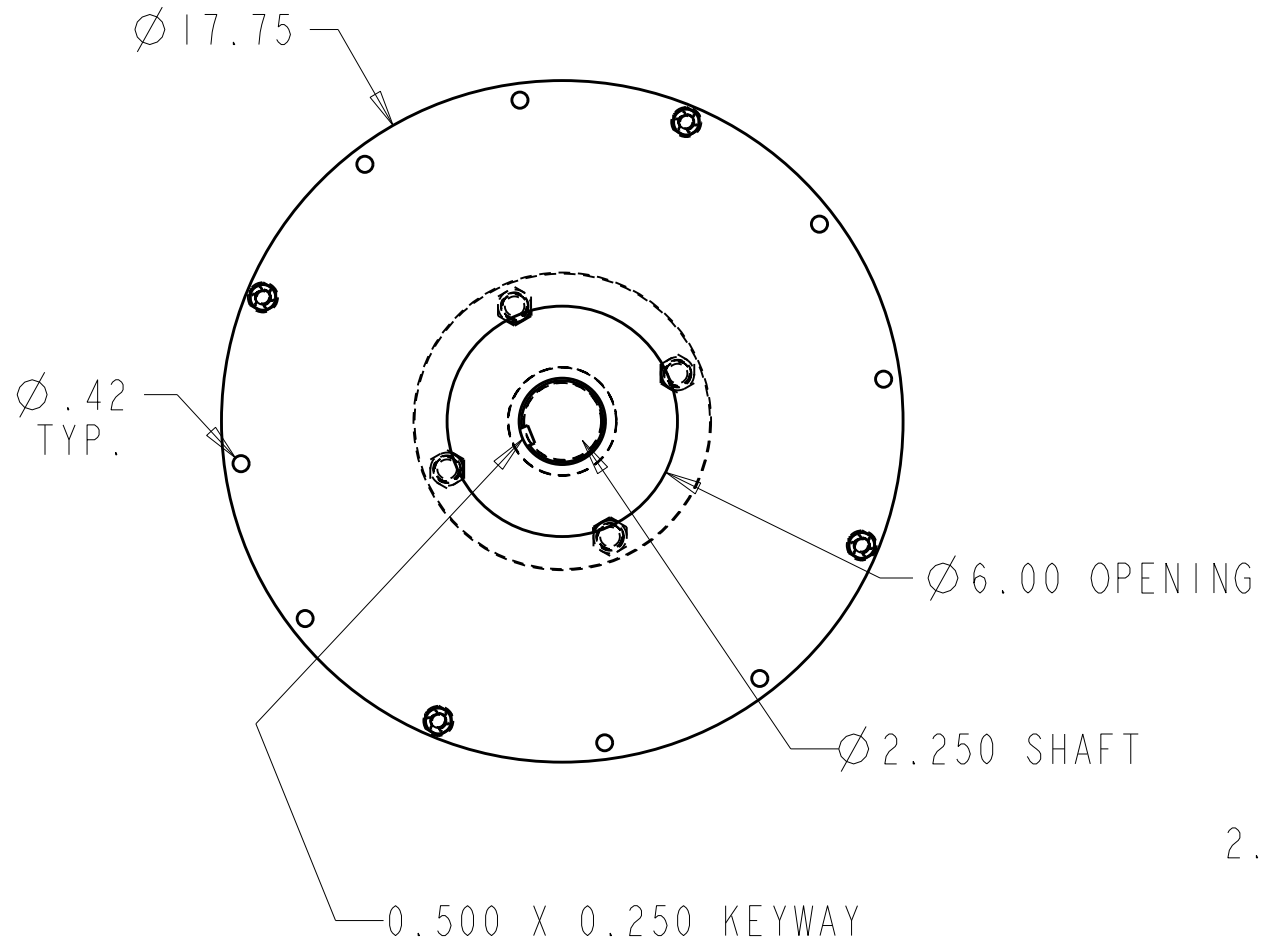
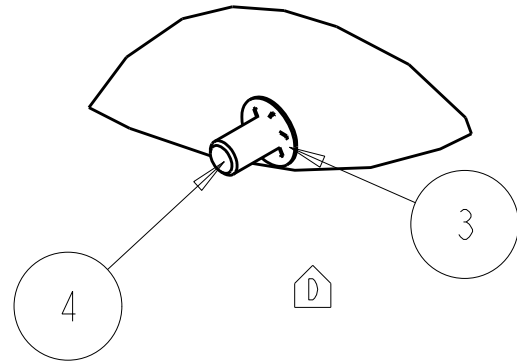

TORQUE CLASS 1  
260-290 N\*M

BILL OF MATERIAL			
ITEM	QTY	DESCRIPTION	PART NUMBER
1	1	GUARD, STUB SHAFT, SAE #3 FLYWHEEL, FIREPUMP	8611
2	1	STUB SHAFT, SAE #3 FLYWHEEL, HAYES #, FIREPUMP	9624
3	4	RETAINING WASHER, PUSHNUT, 3/8" BOLT	16662-06
4	4	SCREW, CAP, HEX HEAD, M10-1.5	HHCS_M10
5	4	SCREW, CAP, HEX HEAD, M16 x 50	HHCS_M16_50

NOTES:  
1. MASS: 13.9 LBS, INERTIA: 67.49 IB.IN^2

This document contains confidential and trade secret information, is the property of Cummins Fire Power LLC and is given to the receiver in confidence. The receiver, by receiving and retaining of the document accepts the document in confidence and agrees that, except as authorized in writing by Cummins NPower, it will (1) not use the document or any copy thereof or the confidential or trade secret information therein, (2) not copy the document, (3) not disclose to others either the document or the confidential or trade secret information therein, and (4) upon completion of the need to retain the document, or upon demand, return the document, all copies thereof, and all material copied therefrom. COPYRIGHT Cummins Fire Power LLC



CUMMINS FIRE POWER LLC  
CORPORATE OFFICE  
1600 BUERKLE ROAD  
WHITE BEAR LAKE, MN  
WWW.CUMMINSFIREPOWER.COM

CUSTOM DESIGN  
AND UPFIT CENTER  
875 LAWRENCE DRIVE  
DEPERE, WISCONSIN

UNLESS OTHERWISE SPECIFIED ALL DIMENSION TOLERANCES ARE

ANGULAR DIMENSIONS ± 1°	IMPERIAL UNITS	METRIC UNITS
THIRD ANGLE PROJECTION	MACHINE TOLERANCES .XX ± 0.010 .XX ± 0.005	MACHINE TOLERANCES .X ± 0.4 .XX ± 0.2
	FORM TOLERANCES .XX ± 0.030 .XX ± 0.015	FORM TOLERANCES .X ± 0.8 .XX ± 0.4
	FAB TOLERANCES .XX ± 0.060 .XX ± 0.030	FAB TOLERANCES .X ± 1.5 .XX ± 0.8

ASSEMBLY, STUB SHAFT, 2.25" DIA FIREPUMP		
DWG UNITS: IN/LB/S	DRAWN BY: DAVE N <b>PRO-ENGINEER</b>	DATE: 15OCT2004 INIT ECO:
SCALE: 0.200	SHEET 1 OF 1	DRAWING NO: 8619
EST WEIGHT: 33.399		

REV	ECO	DESCRIPTION OF REVISION	REV BY	DATE
D	2010-098	ADDED RETAINING FASTENERS	DAN	04-MAR-10
C	2009-620	ADDED MASS & INERTIA DATA	S DUBICK	12/23/09





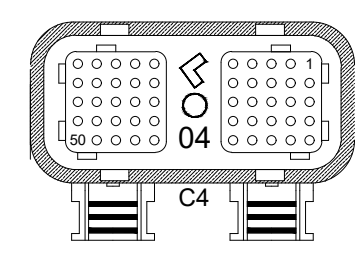
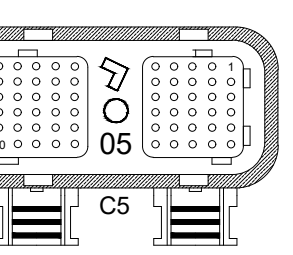
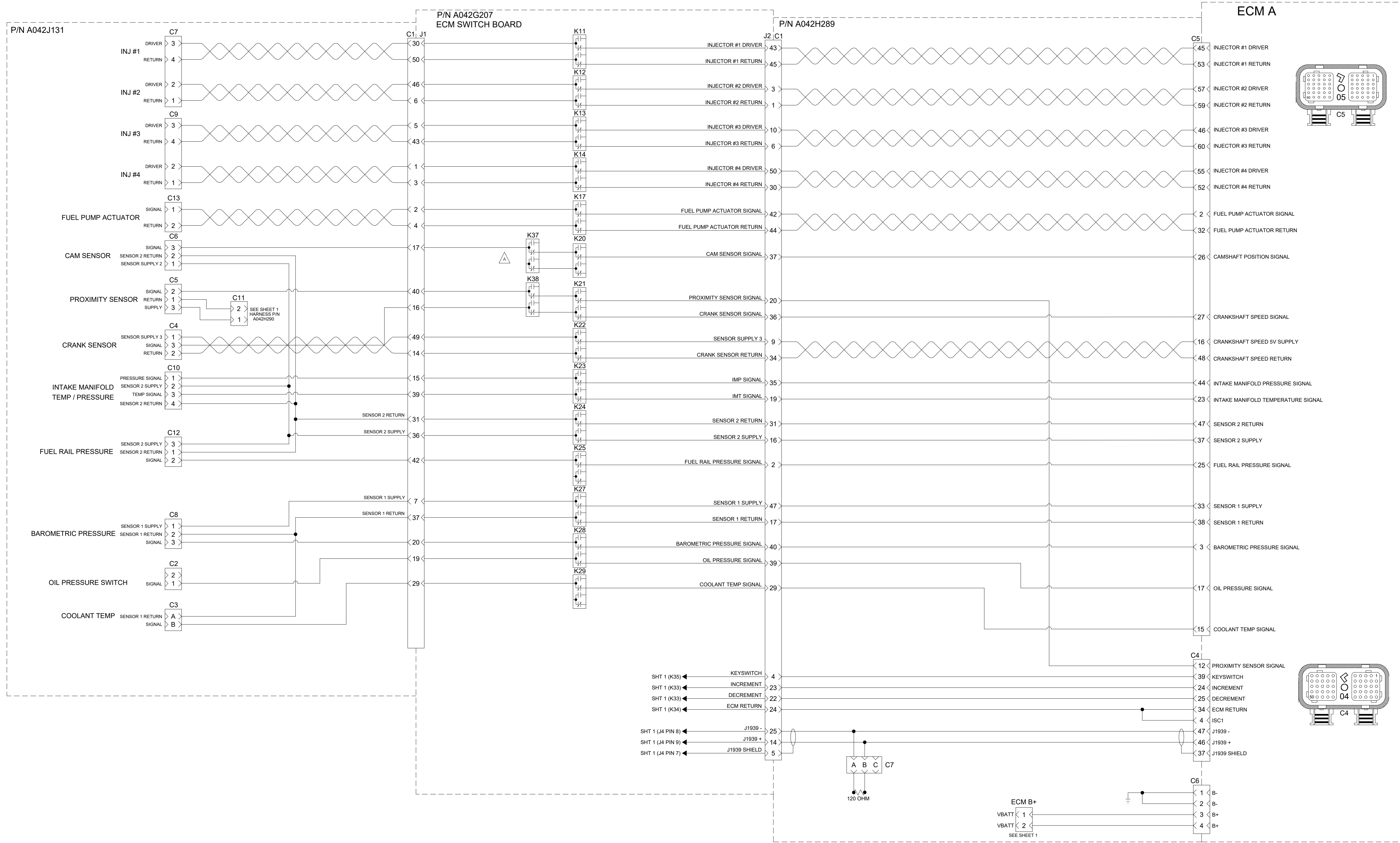

This document contains confidential and trade secret information. It is the property of Cummins NPower LLC and is loaned to the recipient in confidence. The recipient, by receiving and retaining this document, accepts the responsibility to maintain the confidentiality of the information contained herein. (1) not to disclose to others without the written consent of Cummins NPower LLC; (2) not to use, copy, reproduce, or otherwise disseminate the information contained herein; (3) not to use, copy, reproduce, or otherwise disseminate the information contained herein for any purpose other than that for which it was loaned; (4) to return this document to Cummins NPower LLC upon completion of the loan; (5) to destroy this document and all copies thereof, and all materials copied therefrom, upon termination of the loan. ©2016 Cummins NPower LLC.

UNLESS OTHERWISE SPECIFIED ALL DIMENSION TOLERANCES ARE:  
 ANGULAR DIMENSIONS ± 1°  
 THIRD ANGLE PROJECTION  
 DIMENSIONS IN INCHES AND DECIMALS THEREOF  
 DIMENSIONS IN MILLIMETERS AND DECIMALS THEREOF

**Cummins NPower**  
 CUMMINS NPOWER LLC  
 CORPORATE OFFICE  
 1600 BLUEVALE ROAD  
 WHITE BEAR LAKE, MN  
 WWW.CUMMINSNPOWER.COM

CUSTOM DESIGN AND  
 UPTI CENTER  
 875 LAWRENCE DRIVE  
 DEPERE, WISCONSIN

**SCHEMATICS, OVERALL, CFP5E**  
**FPDP GEN II**

DWG UNITS: INCH/LB/S  
 SCALE: 1:1  
 EST WEIGHT:

DRAWN BY: KAK  
**AUTO CAD**  
 SHEET 2 OF 6  
 DRAWING NO: A042J121

DATE: 22 NOV 2016  
 INIT ECO: 2016-694

REV	DATE	DESCRIPTION OF REVISION	BY
A	2019-037	SEE SHEET 1 FOR DETAILS	JF
REV	ECO	DESCRIPTION OF REVISION	DATE

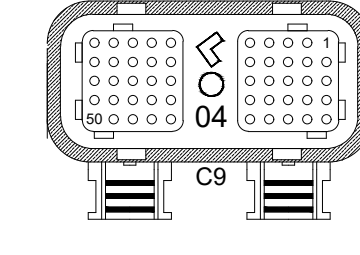
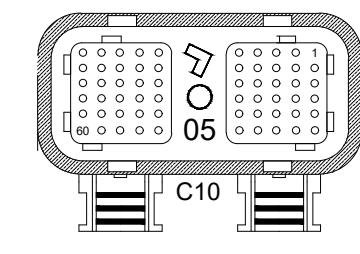
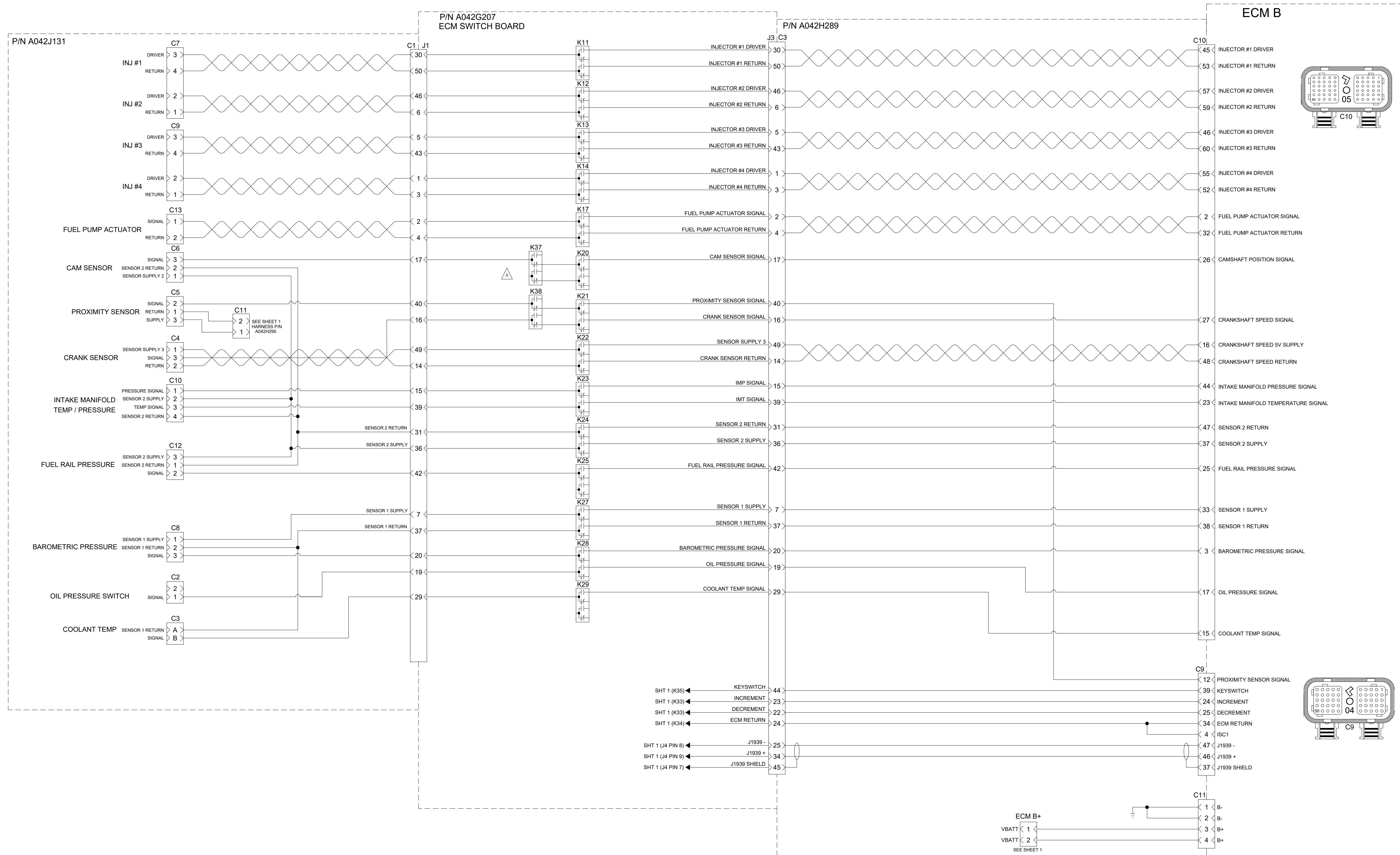

This document contains confidential and trade secret information. It is the property of Cummins NPower LLC and is loaned to the receiver in confidence. The receiver, by receiving and retaining or the document accepts the document in confidence and agrees not to disclose the document to any third party without the prior written consent of Cummins NPower LLC. (1) not to use the document or any copy thereof or the contents or trade secret information therein; (2) not to copy the document; (3) not to disclose to others either the document or the confidential or trade secret information therein; and (4) to use the document only for the purposes intended by Cummins NPower LLC. If you are not the intended recipient, you should not disseminate, distribute or copy this document. If you have received this document by mistake, please notify the sender immediately by e-mail at [www.cumminsnpower.com](mailto:www.cumminsnpower.com).

**UNLESS OTHERWISE SPECIFIED ALL DIMENSION TOLERANCES ARE:**

ANGULAR DIMENSIONS ± 1°	IMPERIAL UNITS	METRIC UNITS
THIRD ANGLE PROJECTION	INCH/LB/S	INCH/LB/S
	± 0.005	± 0.127
	± 0.010	± 0.254
	± 0.015	± 0.381
	± 0.030	± 0.762

**SCHEMATICS, OVERALL, CFP5E**  
**FPDP GEN II**  
 DWG UNITS: INCH/LB/S  
 SCALE: 1:1  
 EST WEIGHT: SHEET 3 OF 6  
 DRAWN BY: KAK  
 DATE: 24JAN2019  
 DATE: 22 NOV 2016  
 INIT ECO: 2016-694  
 DRAWING NO: A042J121

REV	DATE	DESCRIPTION OF REVISION	BY	DATE
A	2019-037	SEE SHEET 1 FOR DETAILS	JF	24JAN2019
REV	ECO	DESCRIPTION OF REVISION	BY	DATE

NO ASO OPTION WITH UP TO 3 SWITCHED INPUTS

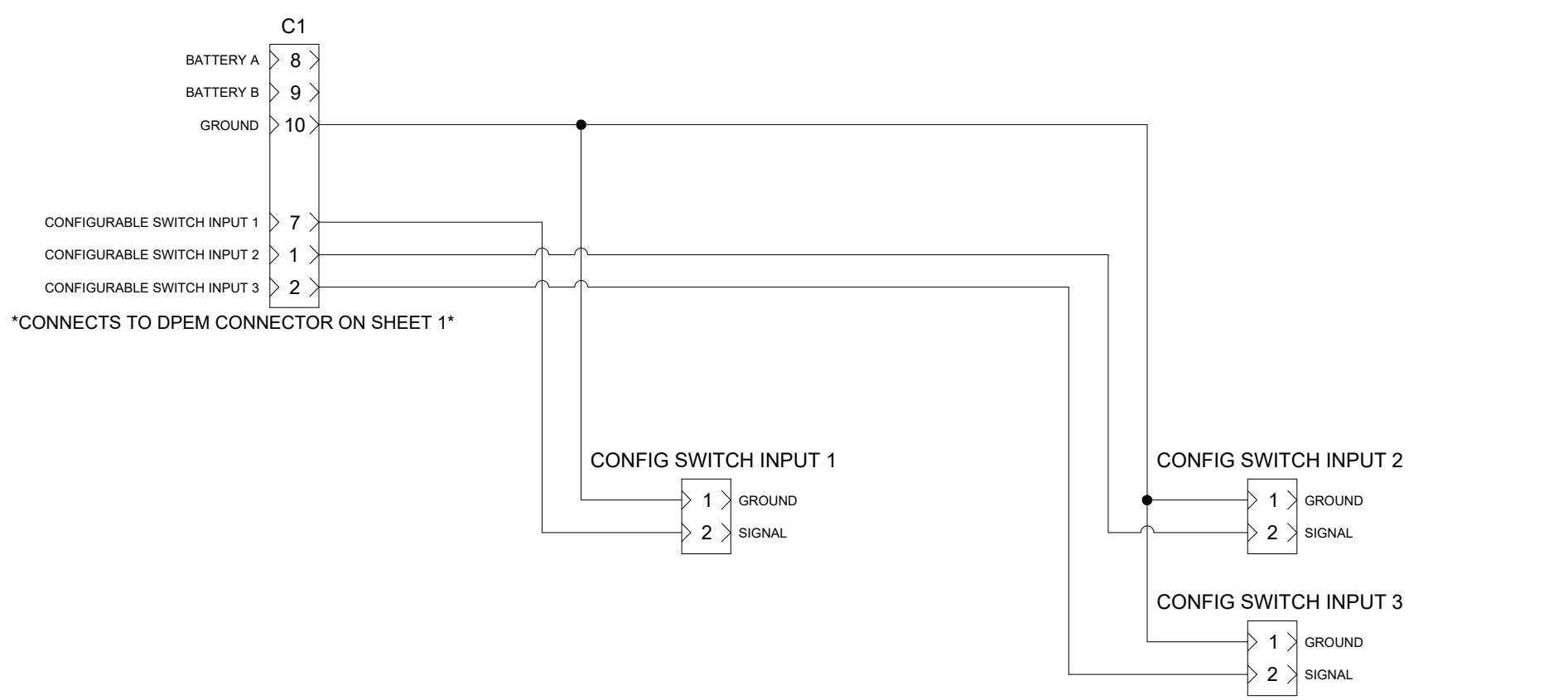

DPEM OPTION WITH NO ASO

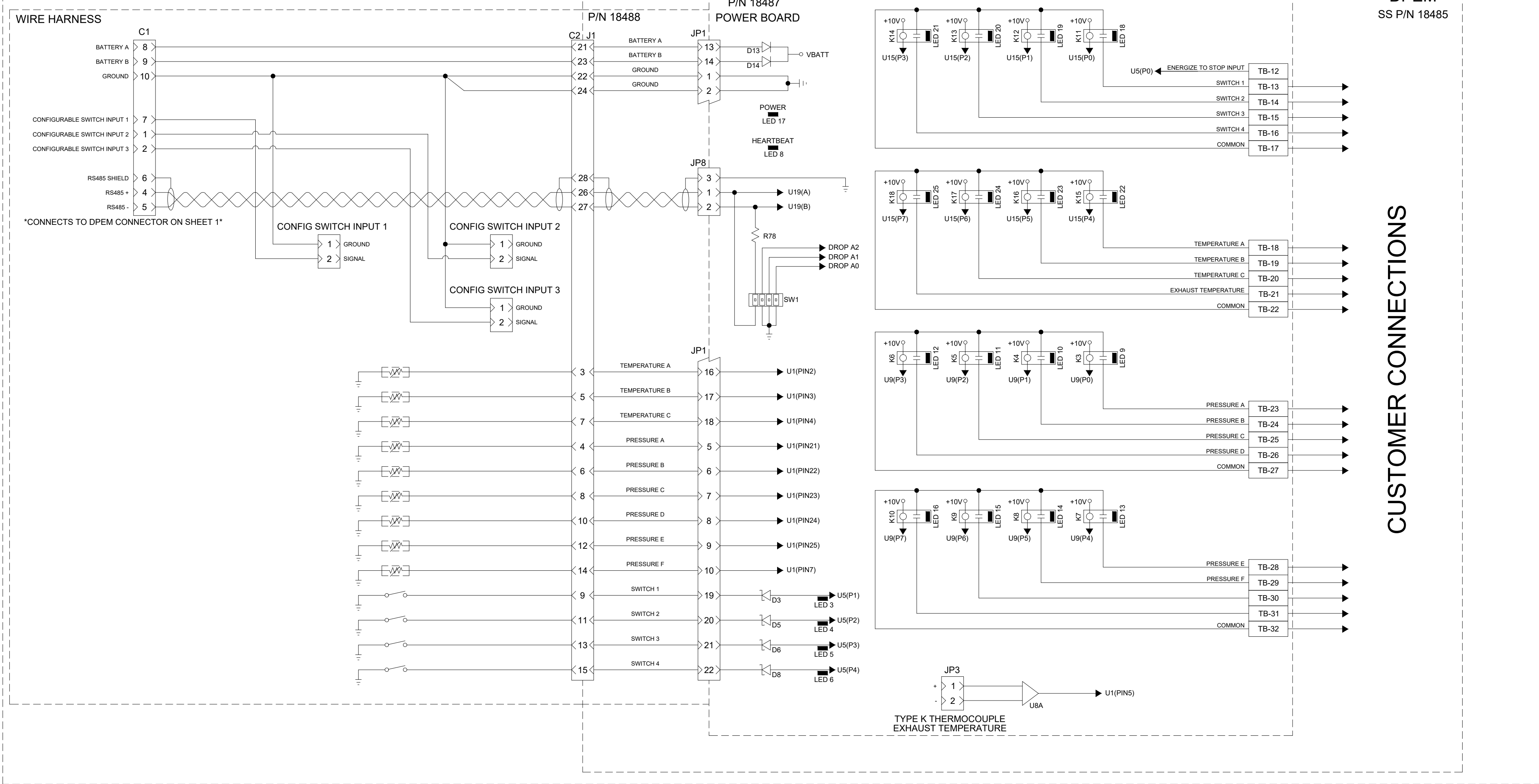

CUSTOMER CONNECTIONS

DPEM  
SS P/N 18485

<small>This document contains confidential and trade secret information. It is the property of Cummins NPower LLC and is given to the receiver in confidence. The receiver, by receiving and retaining or the document accepts the responsibility to maintain and control this information as confidential. It is not to be disclosed, copied, or otherwise made available to any third party without the prior written consent of Cummins NPower LLC. (1) not use the document or any copy thereof or the contents or trade secret information therein; (2) not copy the document; (3) not disclose to others either the document or the confidential or trade secret information therein; and (4) use the document only for the purpose for which it was provided. If you cannot comply with these terms, you must return the document to the sender. ©2016 Cummins NPower LLC.</small>			CUMMINS NPOWER LLC CORPORATE OFFICE 1600 BLUEVALE ROAD WHITE BEAR LAKE, MN WWW.CUMMINSNPOWER.COM	CUSTOM DESIGN AND UPTI CENTER 875 LAWRENCE DRIVE DEPERE, WISCONSIN
UNLESS OTHERWISE SPECIFIED ALL DIMENSION TOLERANCES ARE:				
ANGULAR DIMENSIONS ± 1°	IMPERIAL UNITS	METRIC UNITS	DWG UNITS: INCH/LB/S SCALE: EST WEIGHT:	
THIRD ANGLE PROJECTION	DIMENSIONS 1/16" TO 1/8" ± 0.005 1/8" TO 1/4" ± 0.008 1/4" TO 1/2" ± 0.010 1/2" TO 1" ± 0.012 1" TO 2" ± 0.015	DIMENSIONS 0.254 TO 3.175 ± 0.127 3.175 TO 6.350 ± 0.254 6.350 TO 12.700 ± 0.381 12.700 TO 25.400 ± 0.508 25.400 TO 50.800 ± 0.635	SCHEMATICS, OVERALL, CFP5E FPDP GEN II DRAWN BY: KAK DATE: 22 NOV 2016 INIT ECO: 2016-694	
A	2019-037	SEE SHEET 1 FOR DETAILS	JF	24JAN2019
REV	ECO	DESCRIPTION OF REVISION	BY	DATE

A	2019-037	SEE SHEET 1 FOR DETAILS	JF	24JAN2019
REV	ECO	DESCRIPTION OF REVISION	BY	DATE

IF AIR SHUT-OFF (ASO) IS SELECTED, THE UL/FM LISTING IS REMOVED AS THIS OPTION IS NOT ALLOWED PER THE STANDARDS.

ASO OPTION WITH UP TO 2 SWITCHED INPUTS

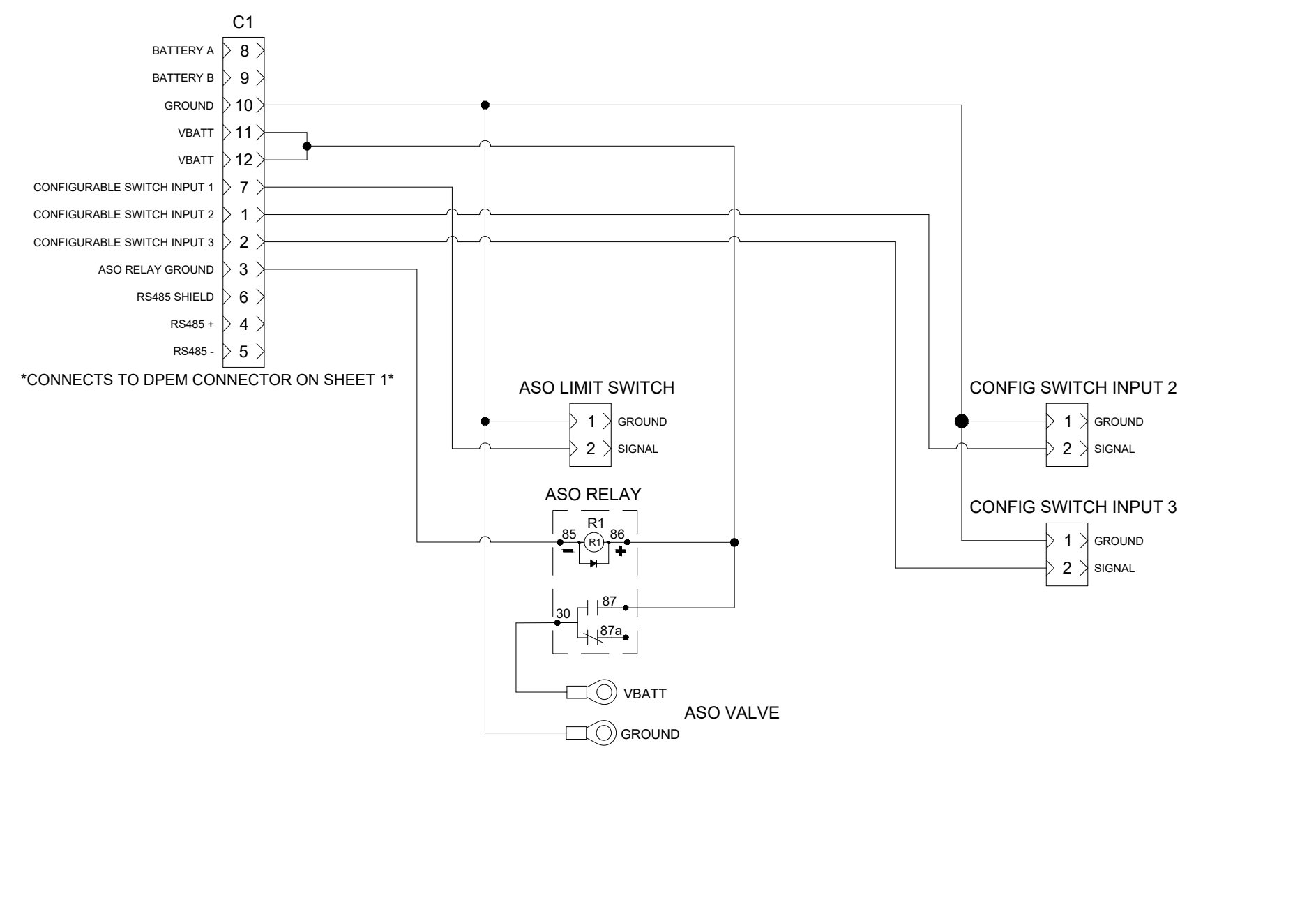

DPEM OPTION WITH ASO

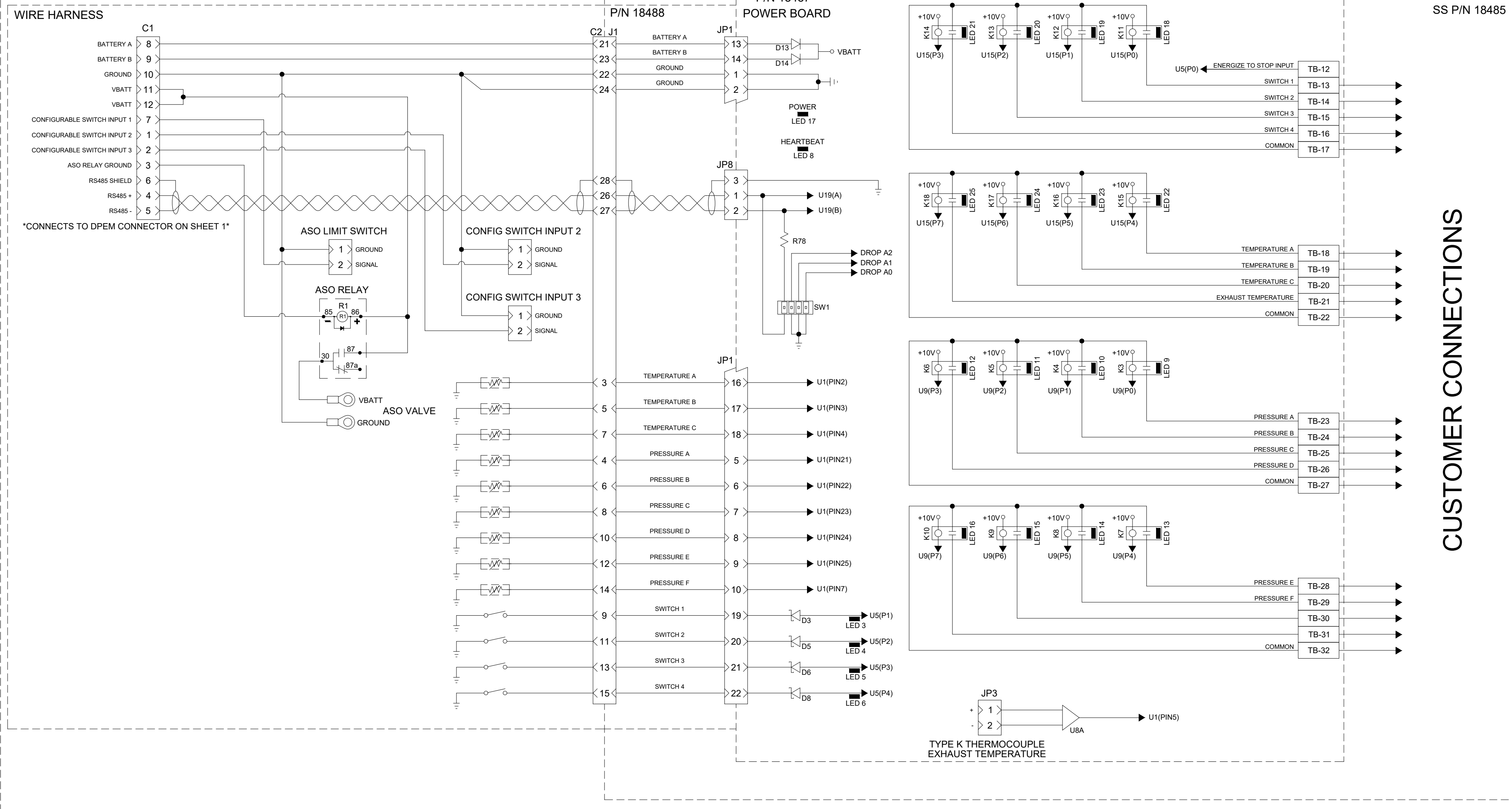

CUSTOMER CONNECTIONS

This document contains confidential and trade secret information. It is the property of Cummins NPower LLC and is loaned to the recipient in confidence. The recipient, by receiving and retaining this document, accepts the responsibility to maintain the confidentiality of the information contained herein. (1) not to disclose this information to any third party; (2) not to copy, reproduce, or disseminate this information; (3) not to use this information for any purpose other than that for which it was provided; (4) to return this information to Cummins NPower LLC upon completion of the project or as otherwise directed. © 2016 Cummins NPower LLC

**NPower**  
 CUMMINS NPOWER LLC  
 CORPORATE OFFICE  
 1600 BLUEVALE ROAD  
 WHITE BEAR LAKE, MN  
 WWW.CUMMINSNPOWER.COM

CUSTOM DESIGN AND  
 UPTI CENTER  
 875 LAWRENCE DRIVE  
 DEPERE, WISCONSIN

SCHEMATICS, OVERALL, CFP5E  
 FPDF GEN II

UNLESS OTHERWISE SPECIFIED ALL DIMENSION TOLERANCES ARE:  
 ANGULAR DIMENSIONS ± 1°  
 THIRD ANGLE PROJECTION

A	2019-037	SEE SHEET 1 FOR DETAILS	JF	24/JAN/2019
REV	ECO	DESCRIPTION OF REVISION	BY	DATE

DWG UNITS: INCH/LB/S  
 SCALE: EST WEIGHT:  
 DRAWN BY: KAK  
 AUTO CAD  
 SHEET 5 OF 6  
 DATE: 22 NOV 2016  
 INIT ECO: 2016-694  
 DRAWING NO: A042J121

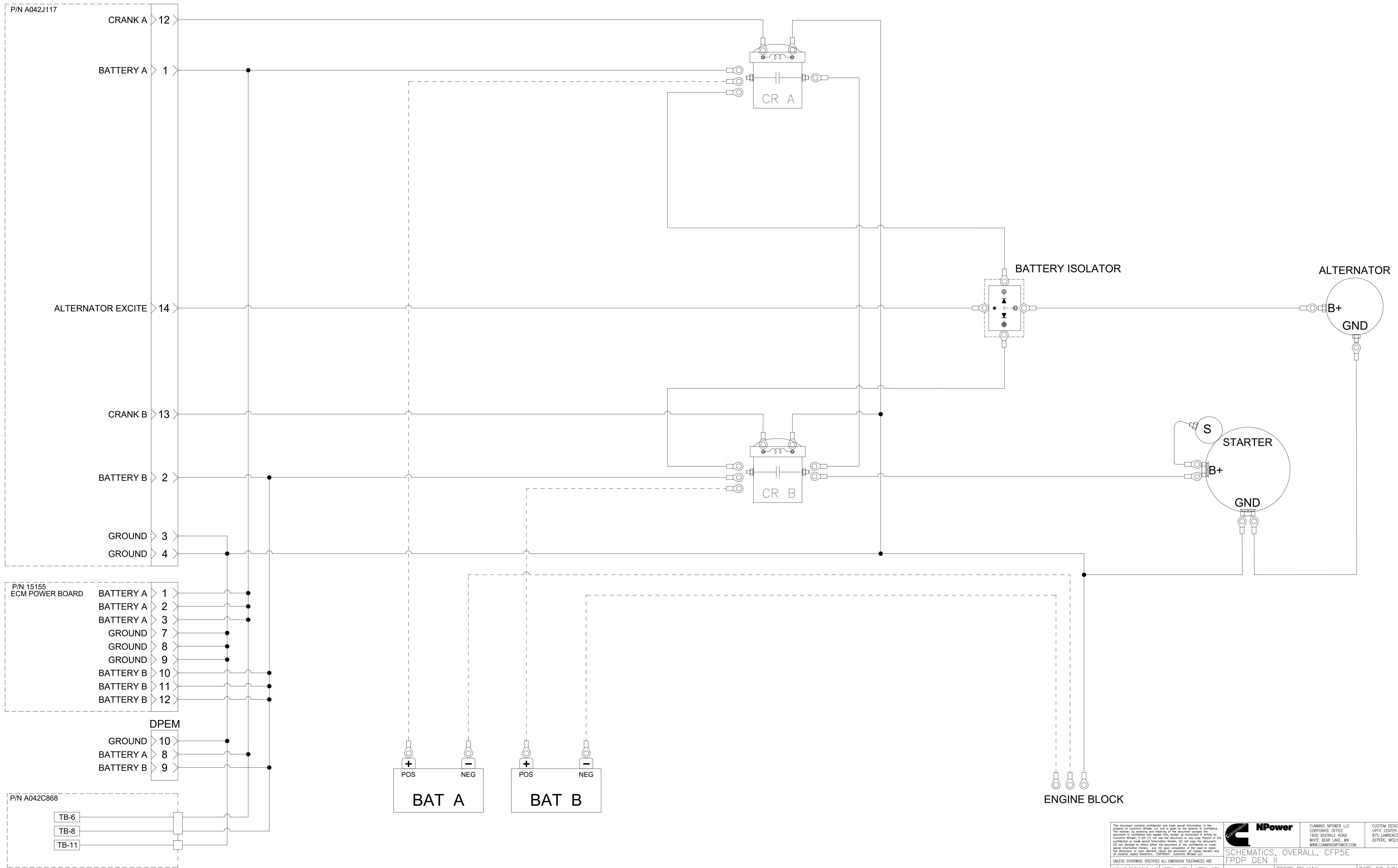

This document contains confidential and trade secret information. It is the property of Cummins NPower LLC and is loaned to the receiver in confidence. The receiver, by receiving and retaining this document, accepts the responsibility to maintain and control this document as confidential. It is not to be disclosed, copied, or otherwise used without the written permission of Cummins NPower LLC. If you are not an authorized recipient, you should not disseminate, distribute, or otherwise use this document. If you are an authorized recipient, you should not disseminate, distribute, or otherwise use this document without the prior written permission of Cummins NPower LLC. If you are not an authorized recipient, you should not disseminate, distribute, or otherwise use this document without the prior written permission of Cummins NPower LLC.

**Cummins NPower**  
 CUMMINS NPOWER LLC  
 CORPORATE OFFICE  
 1600 BLUEVALE ROAD  
 WHITE BEAR LAKE, MN  
 WWW.CUMMINSPOWER.COM

CUSTOM DESIGN AND  
 UPTIT CENTER  
 875 LAWRENCE DRIVE  
 DEPERE, WISCONSIN

**SCHMATICS, OVERALL, CFP5E**  
**FPDP GEN II**

UNLESS OTHERWISE SPECIFIED ALL DIMENSION TOLERANCES ARE:  
 ANGULAR DIMENSIONS ± 1°  
 THIRD ANGLE PROJECTION

REV	DATE	DESCRIPTION OF REVISION	BY	DATE
A	2019-037	SEE SHEET 1 FOR DETAILS	JF	24JAN2019
REV	ECO	DESCRIPTION OF REVISION		

DWG UNITS: INCH/LB/S  
 SCALE: EST WEIGHT:  
 DRAWN BY: KAK  
 DATE: 22 NOV 2016  
 INIT ECO: 2016-694  
 SHEET 6 OF 6  
 DRAWING NO: A042J121

BILL OF MATERIAL

ITEM	QTY	DESCRIPTION	PART NUMBER
1	1	BRACKET, PRESSURE TRANSMITTER	A042E427
2	1	TRANSMITTER, PRESSURE, DWYER: 626-13-GH-PI-E3-S4	A042E425

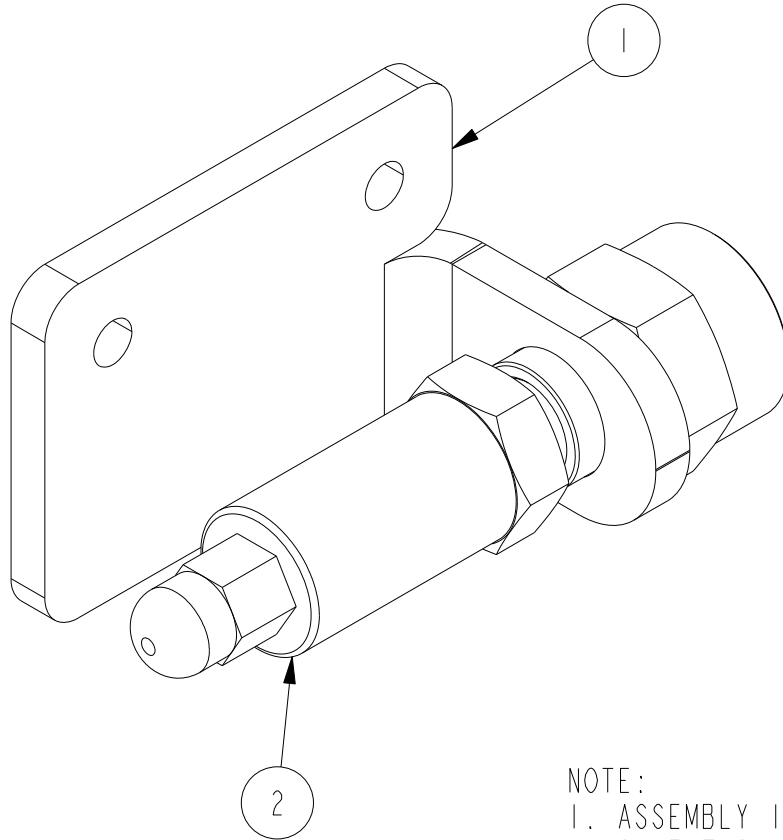

NOTE:  
 1. ASSEMBLY INSTALLS BELOW THE DIGITAL CONTROL PANEL. USING THE SAME TWO HOLES AS THE DIGITAL CONTROL PANEL MOUNTING BRACKET.

This document contains confidential and trade secret information, is the property of Cummins FirePower LLC and is given to the receiver in confidence. The receiver, by receiving and retaining the document accepts the document in confidence and agrees that, except as authorized in writing by Cummins FirePower, it will (1) not use the document or any copy thereof or the confidential or trade secret information therein, (2) not copy the document, (3) not disclose to others either the document or the confidential or trade secret information therein, and (4) upon completion of the need to retain the document, or upon demand, return the document, all copies thereof, and all material copied therefrom. COPYRIGHT Cummins FirePower LLC



CUMMINS FIRE POWER LLC  
 CORPORATE OFFICE  
 1600 BUERKLE ROAD  
 WHITE BEAR LAKE, MN  
 WWW.CUMMINSFIREPOWER.COM

CUSTOM DESIGN  
 AND UPFIT CENTER  
 875 LAWRENCE DRIVE  
 DEPERE, WISCONSIN

UNLESS OTHERWISE SPECIFIED  
 ALL DIMENSION TOLERANCES ARE

ANGULAR DIMENSIONS ± 1°

MACHINED SURFACES	IMPERIAL UNITS	METRIC UNITS
125	MACHINE TOLERANCES	MACHINE TOLERANCES
	.X : ± 0.06	X : ± 1.5
	.XX : ± 0.010	XX : ± 0.5
	.XXX : ± 0.001	XXX : ± 0.05
	WELD TOLERANCES	WELDED TOLERANCES
	.X : ± 0.25	X : ± 5
	.XX : ± 0.12	XX : ± 3
	.XXX : ± 0.06	XXX : ± 1.50

ASSEMBLY, VSPLD  
 PRESSURE TRANSMITTER

DWG UNITS:  
 IN/LB/S

DRAWN BY: PBS

DATE: 09APR2015

**PRO-ENGINEER**

INIT ECO: 2015-227

EST WEIGHT: 1.404

SHEET  
 1 OF 1

DRAWING NO:  
 A042E428

REV	ECO	DESCRIPTION OF REVISION	REV BY	DATE