

Publication TP-03167

DriveTrain Plus™ by ArvinMeritor Product Identification Guide

Issued 03-04

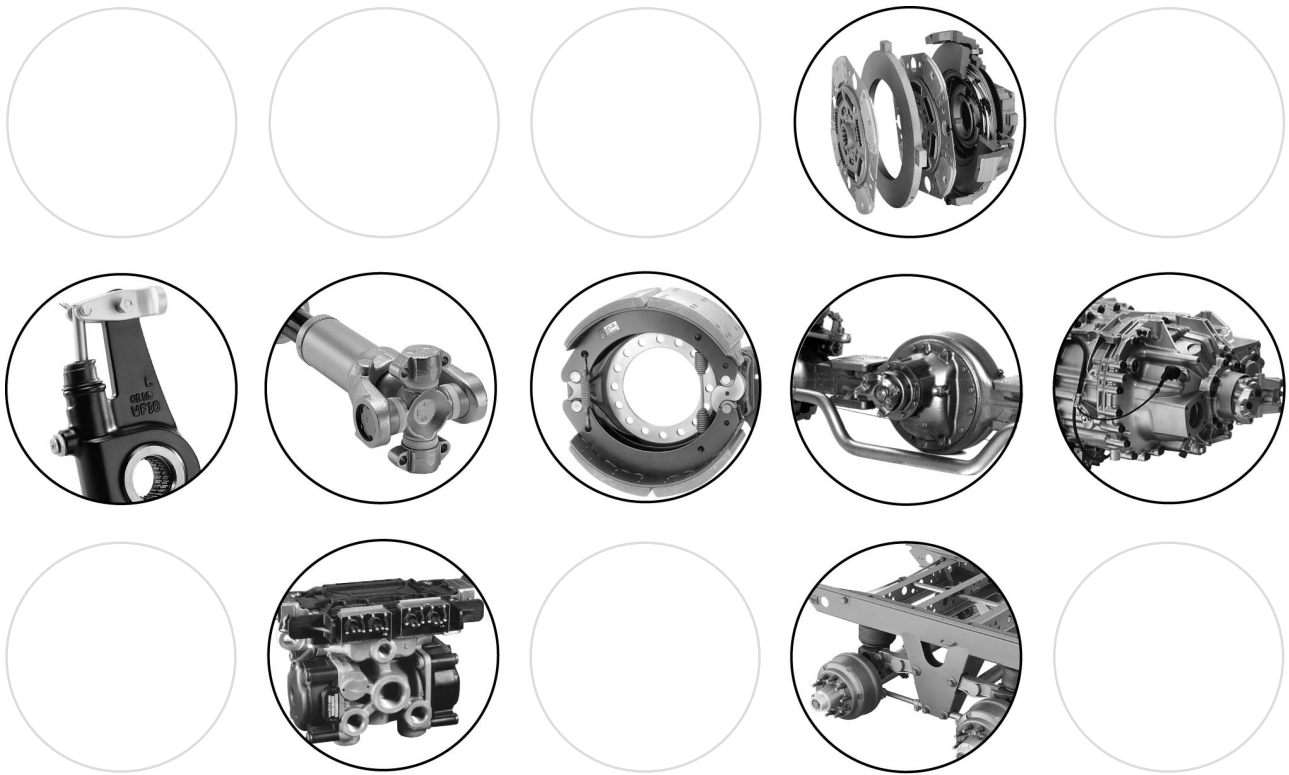

Overview

This publication provides identification information for Meritor, Meritor WABCO and Gabriel products. Product pictures and drawings, identification tag locations and model nomenclatures are provided.

How to Obtain Maintenance and Service Information

On the Web

Visit the DriveTrain Plus™ by ArvinMeritor Tech Library at drivetrainplus.com to easily access product and service information. The Library also offers an interactive and printable Literature Order Form.

ArvinMeritor's Customer Service Center

Call ArvinMeritor's Customer Service Center at 800-535-5560.

Technical Electronic Library on CD

The DriveTrain Plus™ by ArvinMeritor Technical Electronic Library on CD contains product and service information for most Meritor and Meritor WABCO products. The cost is \$20. Specify TP-9853.

Information contained in this publication was in effect at the time the publication was approved for printing and is subject to change without notice or liability. Meritor Heavy Vehicle Systems, LLC, reserves the right to revise the information presented or to discontinue the production of parts described at any time.

pg. 1	Section 1: Brakes	pg. 26	Section 8: Trailer Axles
	Automatic Slack Adjusters		Identification
	Identification	27	Model Nomenclature
2	Four-Piston Quadraulic™ Disc Brake Caliper	28	Section 9: Transmissions
3	Cam Brakes		FreedomLine®
	Identification		Identification
4	Cam Brakes		Model Nomenclature
5	Model Nomenclature	29	Platform “G”
6	Air Disc Brakes		Identification
	Model Nomenclature		Model Nomenclature
7	Wedge Brakes	30	Section 10: Transfer Cases
	Identification		Identification
	Model Nomenclature	31	Model Nomenclature
8	Section 2: Clutches	32	Section 11: Meritor WABCO Components
	Identification		Enhanced Easy-Stop™ Trailer ABS
9	Model Nomenclature		Identification
10	Section 3: Drivelines		External Modulator Valve
	Identification	33	Sensor with Molded Socket
	Yoke Identification		In-Line Filter Valve
12	Section 4: Front Axles		PLC DataMaster™ Trailer Data Extraction Module
	Front Non-Drive Steer Axles		Reverse Detection Module
	Identification		Hydraulic Anti-Lock Braking Systems (ABS)
13	Model Nomenclature	34	Identification
14	Front Drive Steer Axles		Modulator Assembly
	Identification		Sensor with Molded Socket
	Model Nomenclature		Pneumatic ABS for Trucks, Tractors and Buses
15	Model Nomenclature		Identification
16	Model Nomenclature	35	ABS Valve Package — Rear Axle
17	Section 5: Rear Axles		ABS/ATC Valve Package — Rear Axle
	Single, Tandem and Tridem Rear Drive Axles		ABS Valve Package — Front Axle
	Identification		ABS Modulator Valve
18	Model Nomenclature	36	Automatic Traction Control Valve
19	Model Nomenclature		Straight Sensor
20	Section 6: Bus and Coach Axles		Right Angle (90°) Sensor
	Bus and Coach Non-Drive Axles		Air Dryers
	Identification		Identification
21	Bus and Coach Drive Axles	37	Air Compressors
	Identification	38	Air Brake System Valves
	Model Nomenclature	39	Single or Dual Circuit Foot Valve and Pedal
22	Model Nomenclature		Hand-Operated Valves
23	Section 7: Trailer Air Suspension Systems	40	Leveling Valves
	RideStar™ RHP	41	Section 12: Gabriel Shocks
	Identification		Identification
	Model Nomenclature		
24	RideStar™ RFS Series		
	Identification		
25	RideStar™ RFS Series		
	Model Nomenclature		

Automatic Slack Adjusters



Identification

The part number is located on the side of the slack adjuster.

Meritor uses either black, red, yellow, green or blue to color-code an automatic slack adjuster's internal piston actuator piston according to brake type and air chamber size.

Meritor uses a mylar tag on the body of the current-design slack adjuster to identify the color of the internal actuator piston. A color-coded tie wrap was used on previous-design slack adjusters.

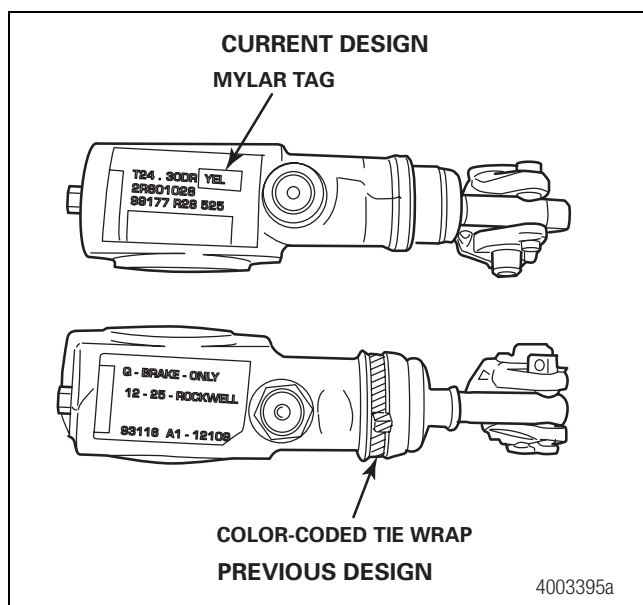

1 Brakes

Four-Piston Quadraulic™ Disc Brake Caliper

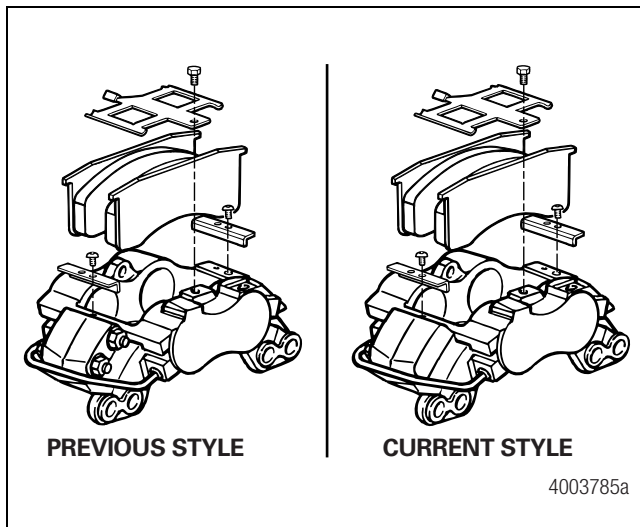

Current Style

Metric caliper bolts

Caliper housing halves held together by bolts in blind holes in the bridge area.

Integral piston/heat shield

Phenolic piston

Previous Style

SAE caliper bolts

Caliper housing halves held together by bolts and nuts in the bridge area.

Separate piston and heat shield

Metal piston

An assembly number is located on the side of the four-piston Quadraulic™ disc brake caliper.

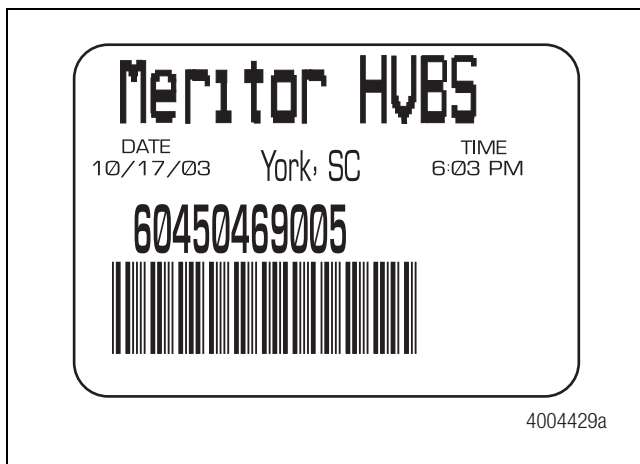

Cam Brakes

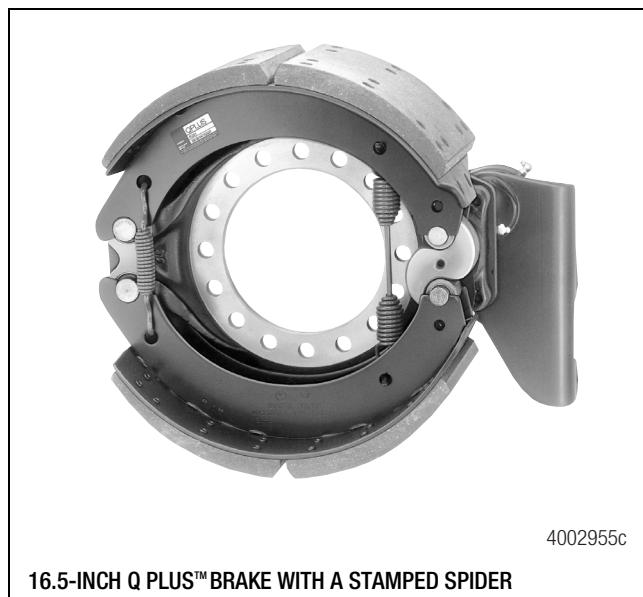

Identification

A model number tag for the brake assembly is located on the camshaft tube. An example of a part number for a 16.5 Q Plus™ brake is QP1 1657 1234X.

For bus and coach, the brakes are identified by a three-letter code on the axle identification plate.

In addition to the model number tag on the cam tube, a brake shoe label is attached to the brake shoe web. This label provides information on brake type, lining material and service parts replacement number.

The brake shoe lining also contains identification. The information that exists on the edge code of the lining is listed in the following order.

- Meritor stamped logo
- Lining mix designation
- Friction code
- Friction Material Standards Institute (FMSI) number, four to eight spaces
- Block type
- Meritor part number, last four digits
- Word drawing engineering change letter
- Julian date, four or five characters

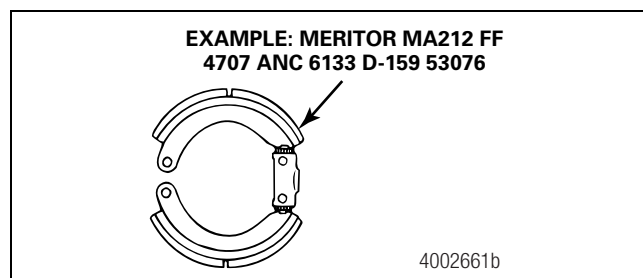
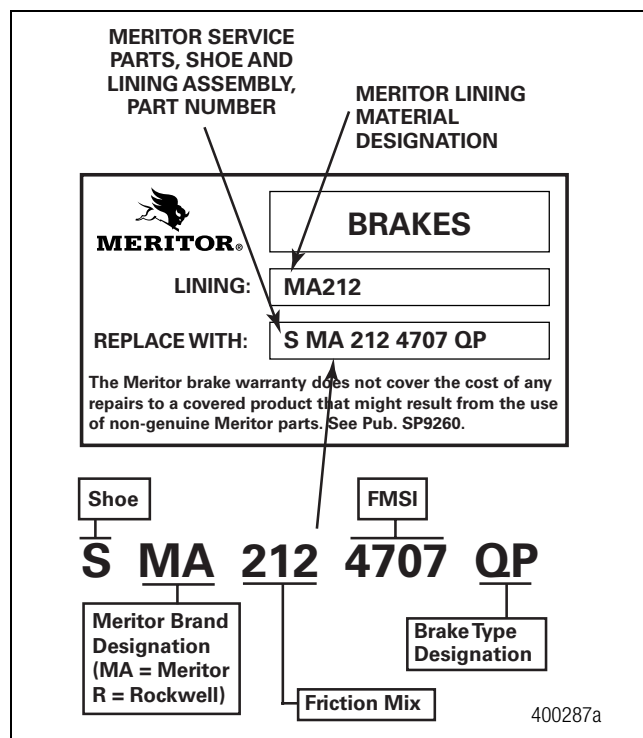

Identifying Q Plus™ LX500 and MX500 Brakes

NOTE: Do not remove the identification tag from the camshaft bracket during the extended maintenance period.

You can identify Q Plus™ LX500 and MX500 cam brakes by checking the identification tags affixed to the brake.

1. A brake shoe tag identifies the brake as Q Plus™.
2. An additional identification tag imprinted with “**SEE MERITOR MAINTENANCE MANUAL MM-96173 FOR LUBE INFO,**” which is affixed to the brake chamber bracket over the top of the plugged grease hole, identifies the brake as a Q Plus™ LX500 or MX500 brake.
3. Q Plus™ LX500 and MX500 brakes and Meritor automatic slack adjusters do not have grease fittings.

1 Brakes

Cam Brakes

Q Plus™ Components

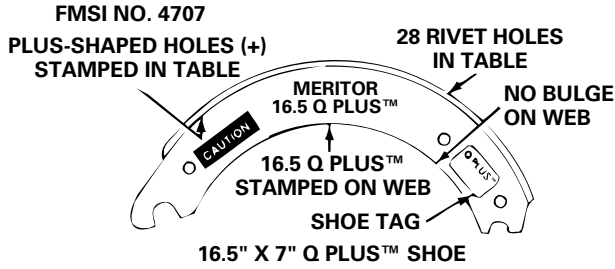

4000323a

Q Series Components

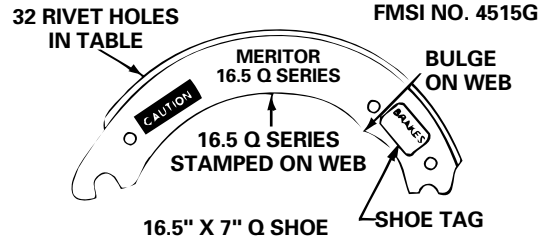

4000324a

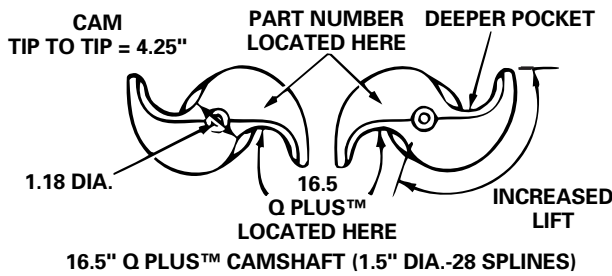

4000325a

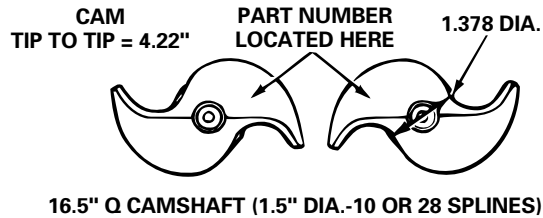

4000326a

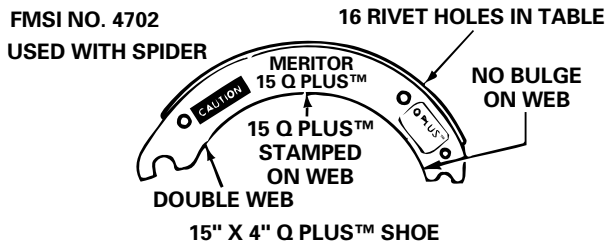

4000327a

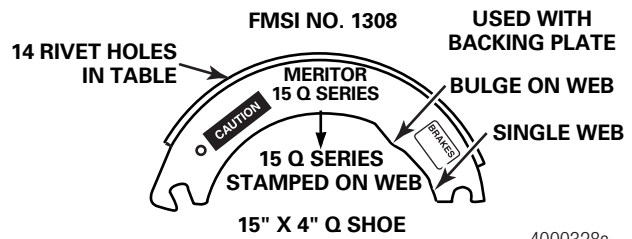

4000328a

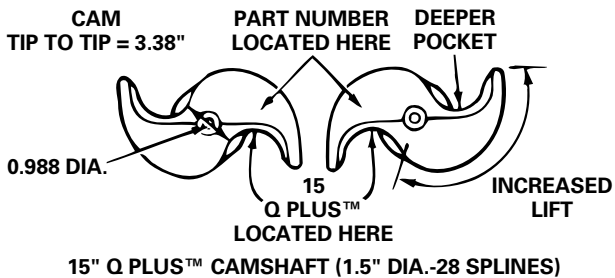

4000329a

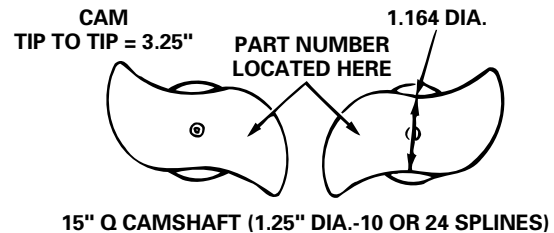

4000330a

Camshafts	Shoes	Return Springs
Q Plus™	Q Plus™	Heavy-duty (blue)
Q Plus™	Q Series	Standard
Q Series	Q Series	Standard

Cam Brakes

Model Nomenclature

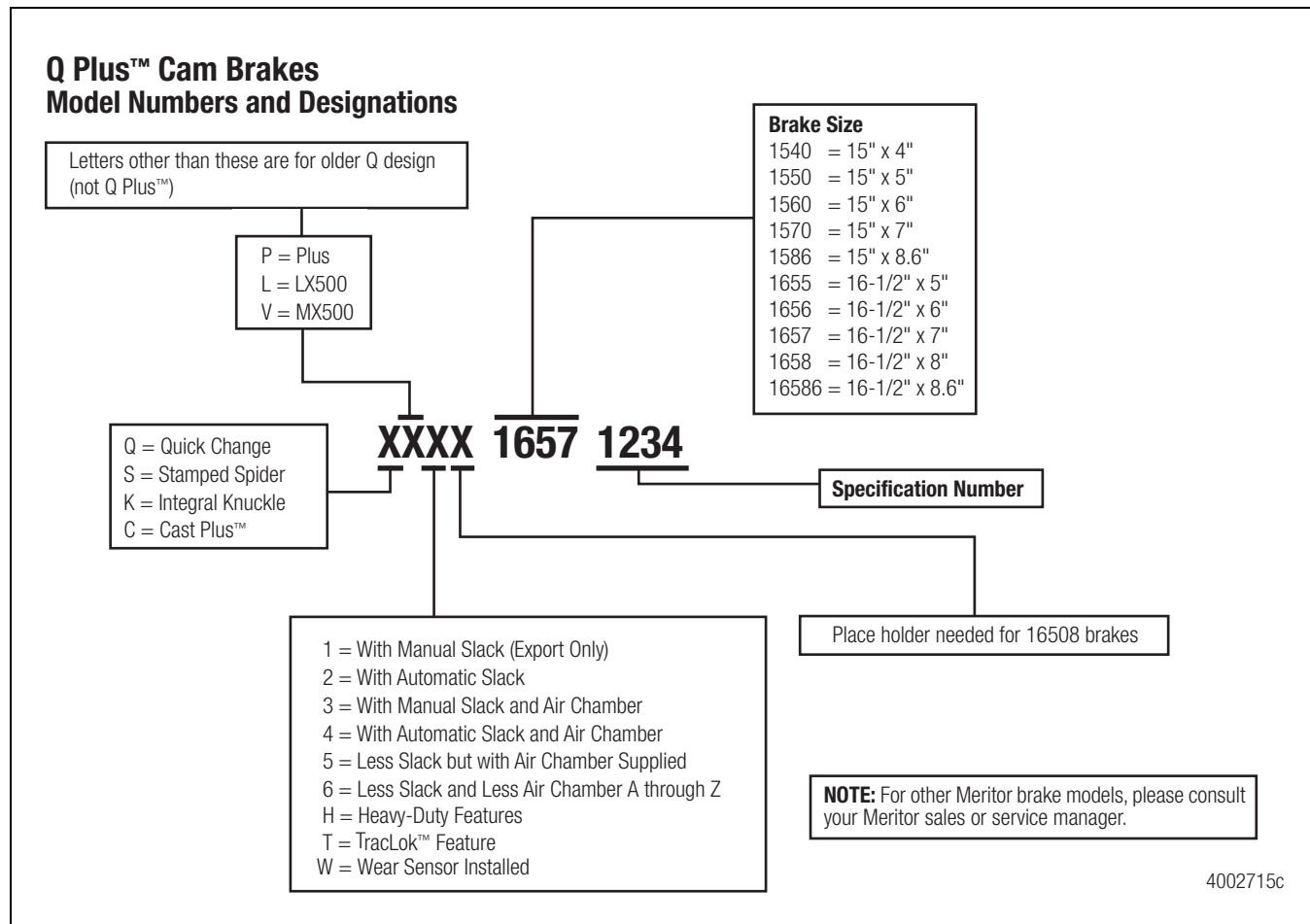

Wedge Brakes

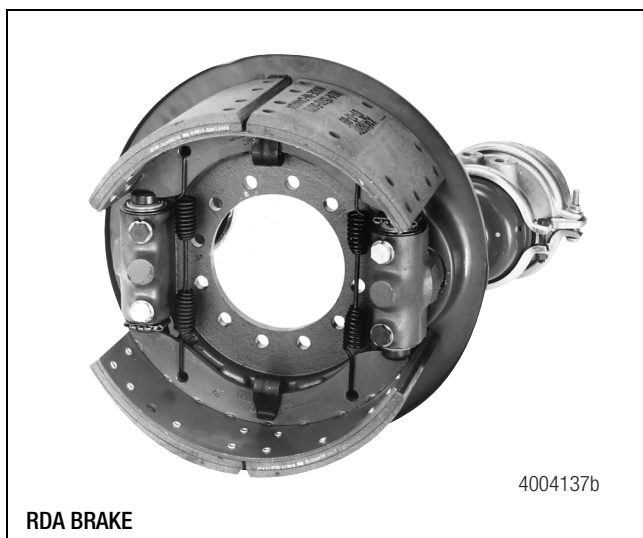

Identification

Wedge brakes are identified by a model number tag that is typically attached to the camshaft tube or dust shield of the brake assembly. An example of a part number for a wedge brake is RSA 1540 1234.

In addition to the model number tag on the cam tube, a brake shoe label is attached to the brake shoe web. This label provides information on the brake type, lining material and service parts replacement number.

For bus and coach, the brakes can be identified by a code on the axle identification plate.

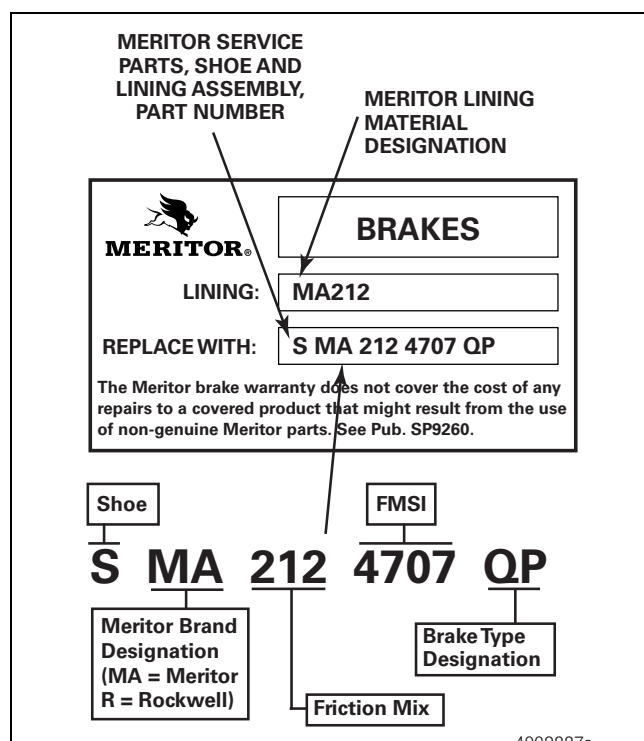
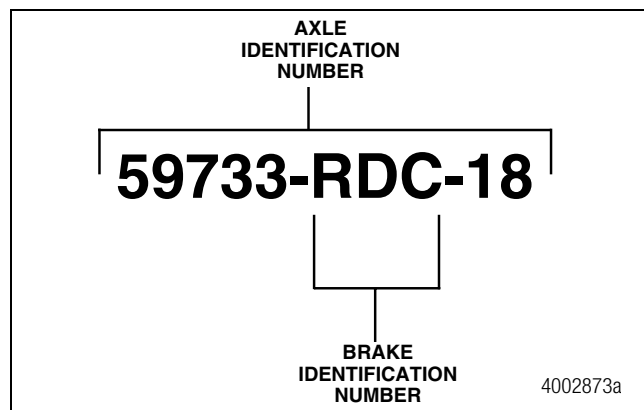
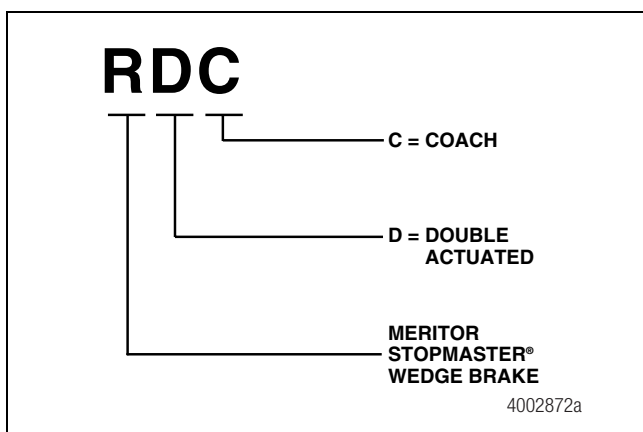

Model Nomenclature

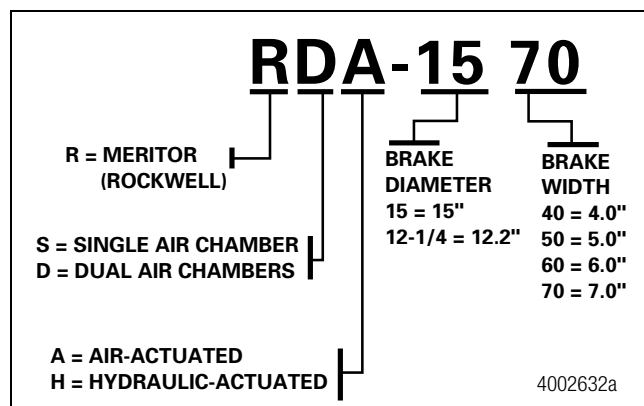

2 Clutches

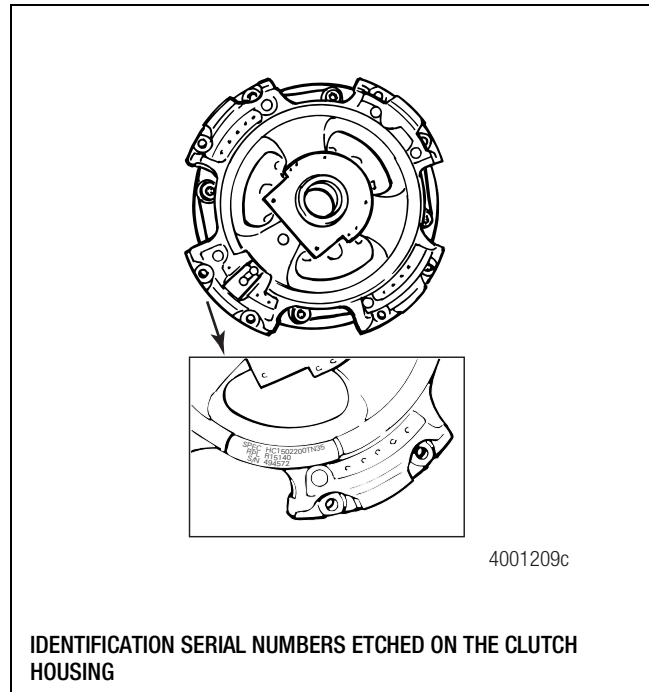
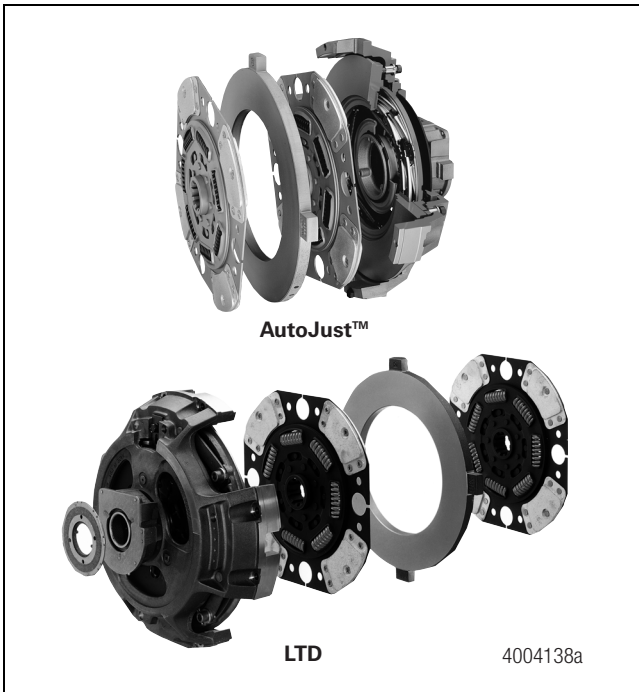

Identification

To identify a clutch, refer to the identification and serial numbers located on the front of the clutch cover. Refer to these numbers when you replace parts.

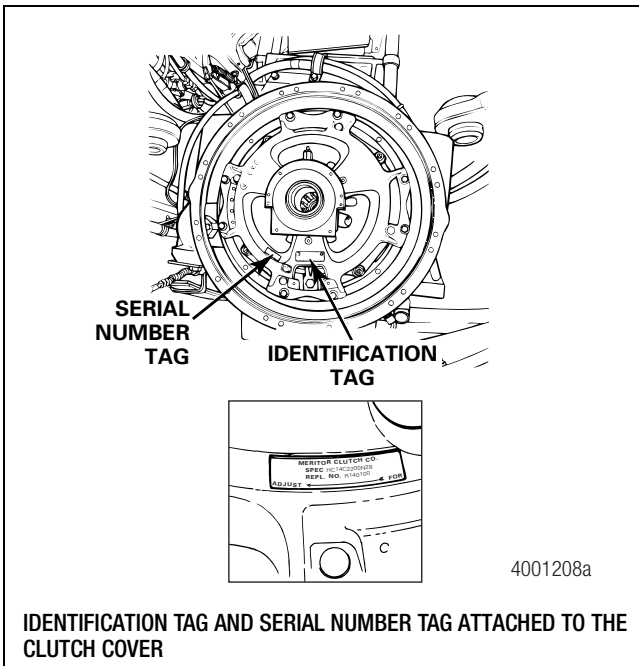

Model Nomenclature

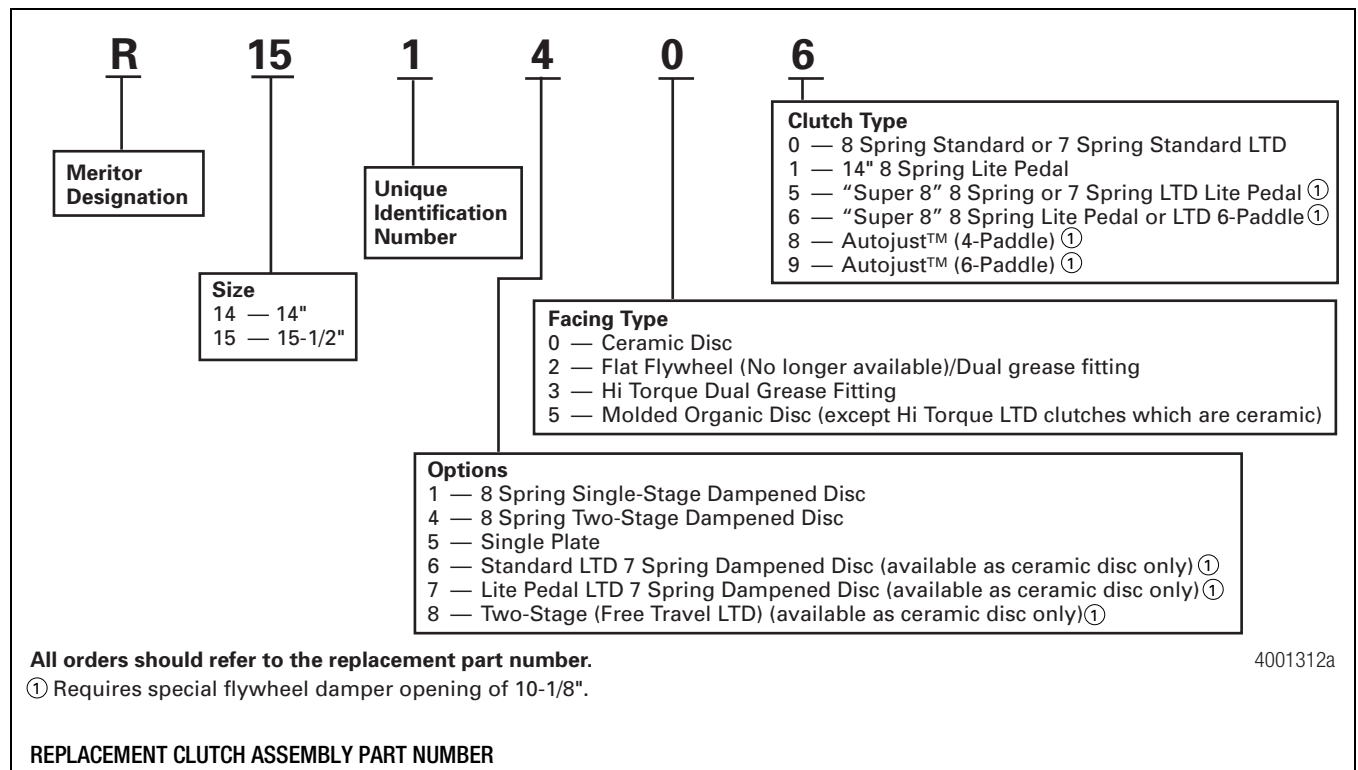
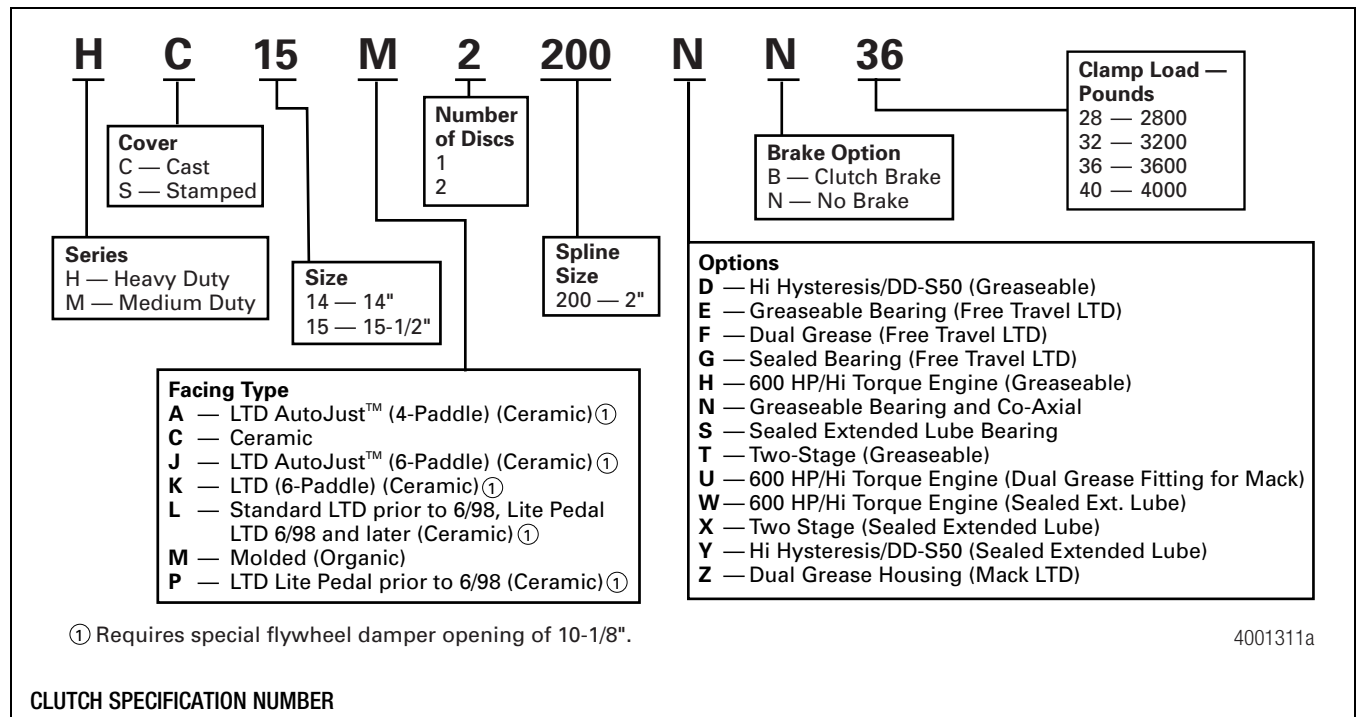

3 Drivelines

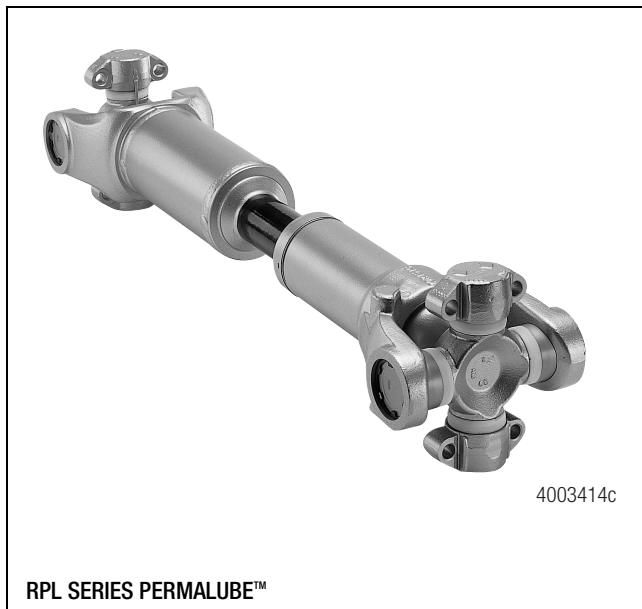

Identification

Meritor driveline components are identified by the following markings on the component.

- Logo stamped on the part
- Balance bosses
- Forging part number which identifies the driveline series

Meritor Driveline Series

16N	58WB
17N	62N
176N	72N
18N	82N
25W*	85WB
20W*	92N

* RPL25 and RPL20 do not follow the above convention and utilize their own unique numbering system.

Yoke Identification

Round Bearing

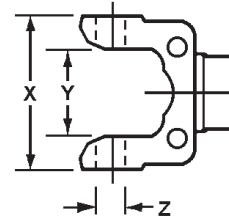

X	Y	Z	Series	Type
Across Earwork	Between Earwork	Bearing Diameter		
	1.44"	.97"	L6N	Inside Snap Ring
2.19"		.94"	10N	Outside Snap Ring
	2.38"	1.06"	131N	Inside Snap Ring
3.47"		1.06"	131N	Outside Snap Ring
	2.56"	1.19"	135N	Inside Snap Ring
3.88"		1.19"	135N	Outside Snap Ring
	3.13"	1.19"	141N	Inside Snap Ring
4.44"		1.19"	141N	Outside Snap Ring
	3.13"	1.38"	148N	Thrust Plate
4.44"		1.38"	148N	Thrust Plate
4.19"		1.38"	148N	Thrust Plate
5.25"		1.38"	155N	Thrust Plate
4.97"		1.38"	155N	Thrust Plate
5.31"		1.88"	16N	Cover Plate
6.09"		1.94"	17N	Cover Plate
7.00"		1.94"	176N	Cover Plate
7.55"		1.94"	18N	Cover Plate
5.19"		1.63"	750N	Outside Snap Ring
6.06"		1.94"	850N	Outside Snap Ring
7.89"		2.50"	950N	Outside Snap Ring
7.00"		2.06"	20RPL	Wing/Outside Snap Ring
8.33"		2.06"	25RPL	Wing/Outside Snap Ring

Identification

U-Bolt and Strap and Bolt

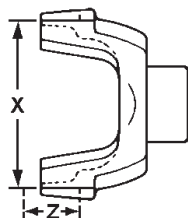

X	Z	
Between Lugs	Bearing Diameter	Series
3.22"	1.06"	131N
3.63"	1.06"	133N
3.63"	1.19"	135N
4.19"	1.19"	141N
4.19"	1.38"	148N
4.97"	1.38"	155N
5.31"	1.88"	16N
6.19"	1.94"	17N
7.09"	1.94"	176N
7.63"	1.94"	18N

RPL Driveline

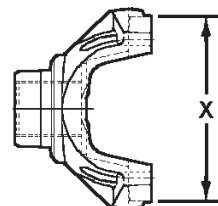

X	
Between Lugs	Series
7.06"	20WYS
8.38"	25WYS

Wing Bearing

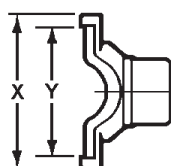

X	Y	
Swing Diameter	Pilot Diameter	Series
5.63"	5.31"	58WB
5.84"	5.53"	62N
6.22"	5.84"	72N
6.88"	6.50"	85WB
8.50"	8.13"	82N
8.63"	8.25"	92N

Drivelines

4 Front Axles

Front Non-Drive Steer Axles

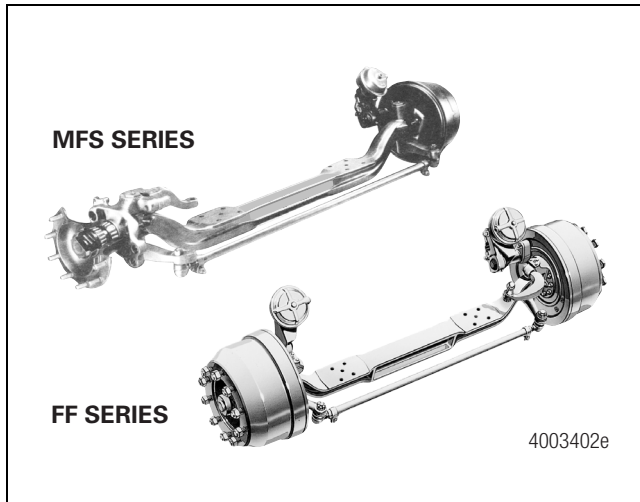

Identification

The axle build information and assembly date for Meritor front non-drive steer axles is on the axle identification tag.

The identification tag is fastened to the center of the beam at the front surface. The axle assembly date is located in either the lower right-hand or left-hand corner of the tag.

The Julian method is used to indicate the axle assembly date. The first two digits indicate the year, and the last three digits indicate the day of the year.

In the following example, 01 is the year 2001 and 327 refers to November 22.

To identify the model number, refer to the identification plate on the front of the beam. Use the complete model number to obtain parts.

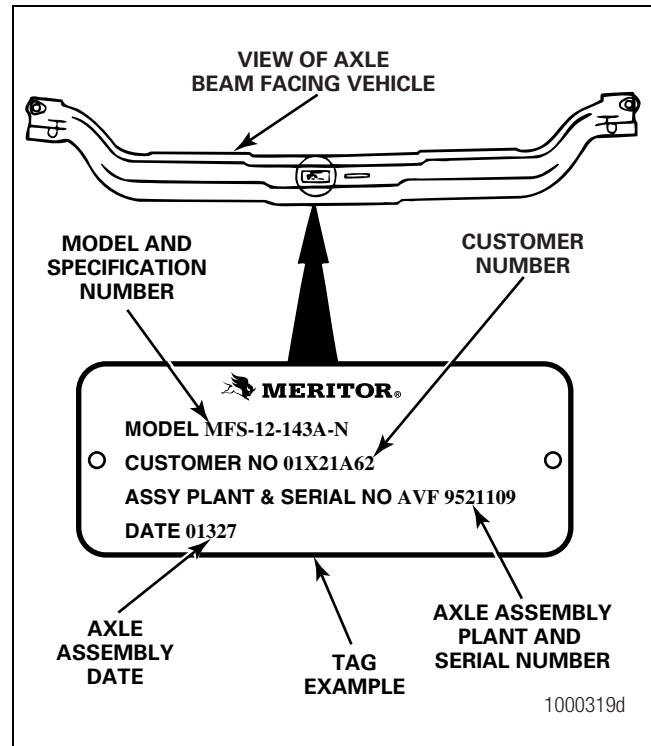

Front Non-Drive Steer Axles

Model Nomenclature

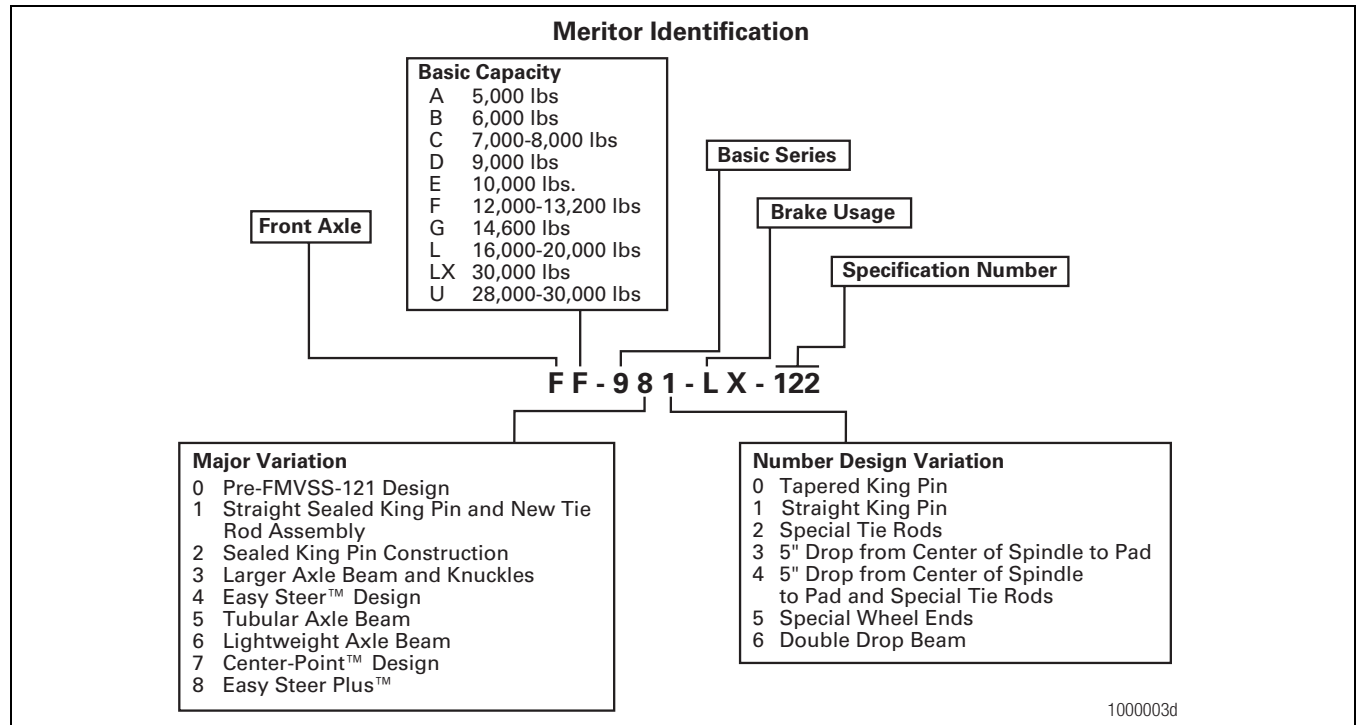

Front Axles

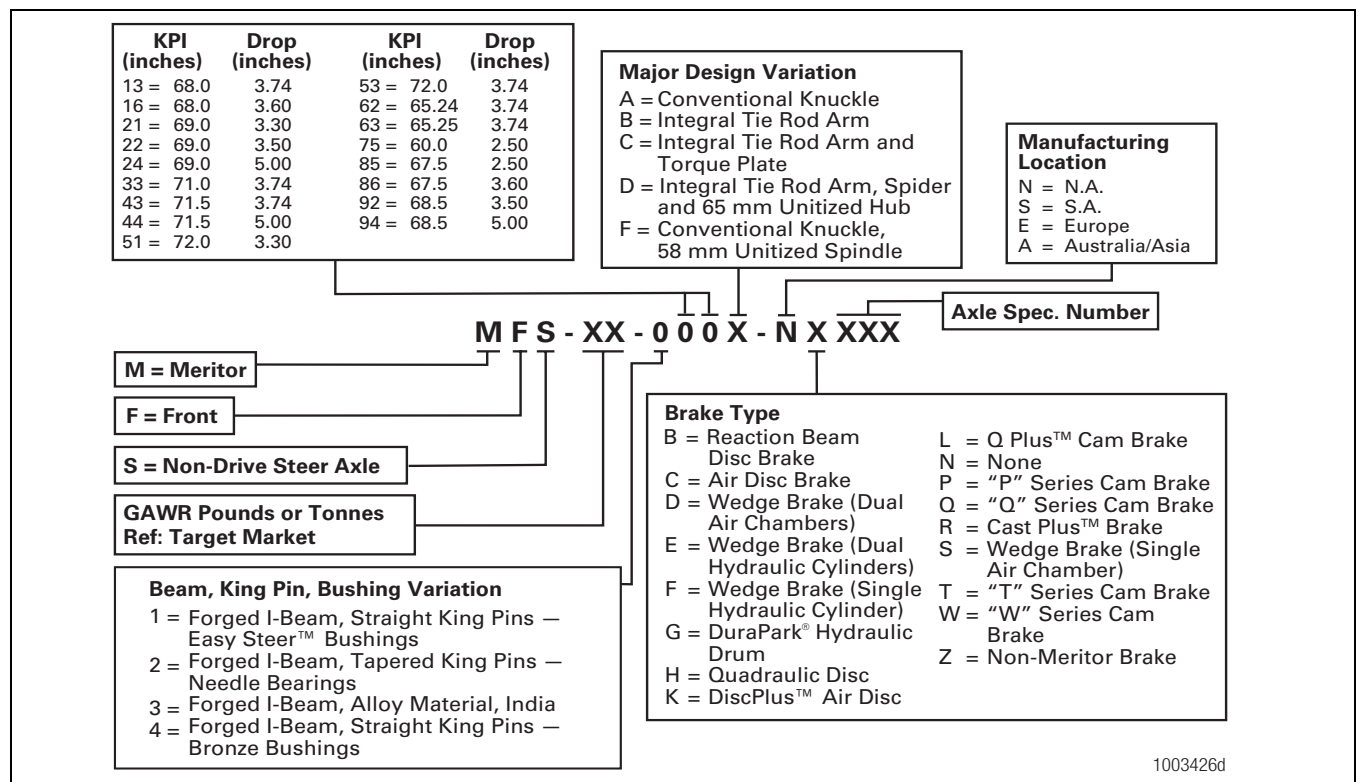

4 Front Axles

Front Drive Steer Axles

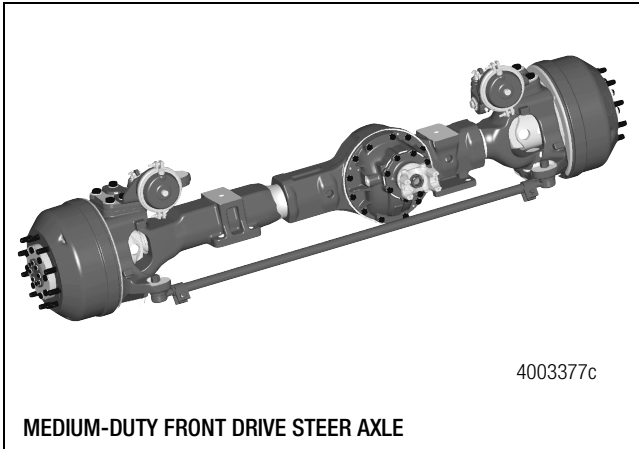

Identification

The axle build information and assembly date for Meritor front drive steer axles are on the axle identification tag. The identification tag is fastened to the front side of the axle housing.

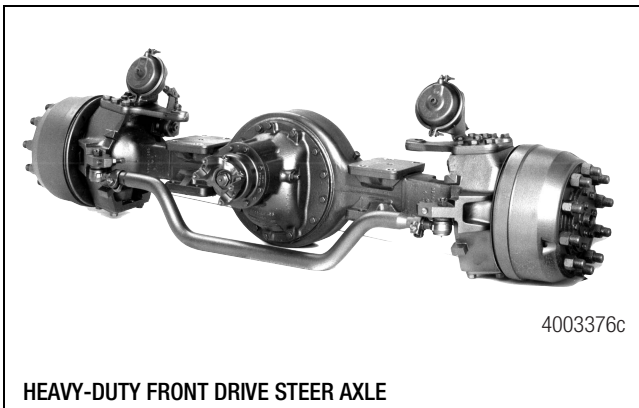
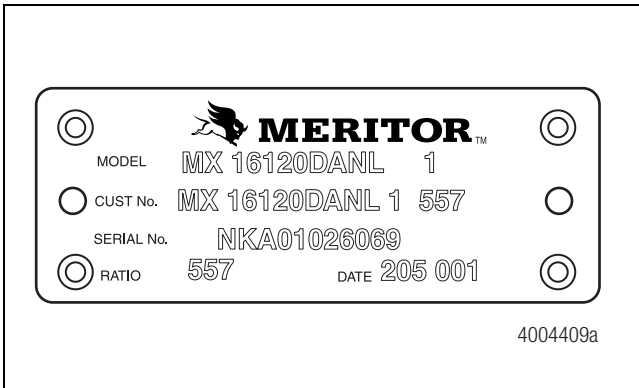

Model Nomenclature

Meritor heavy-duty front drive steer axle models manufactured before 1989 were identified as shown in the figure below.

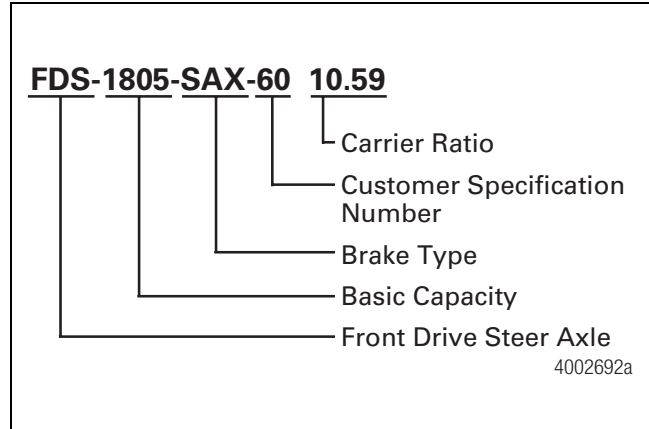

Front Drive Steer Axles

Medium-duty front drive steer axle models are identified by a letter and number system. The letters and numbers give important information about the specific axle model.

The first seven positions of the designations identify a basic axle model. The second group of letters and numbers identify particular specifications.

Model Nomenclature

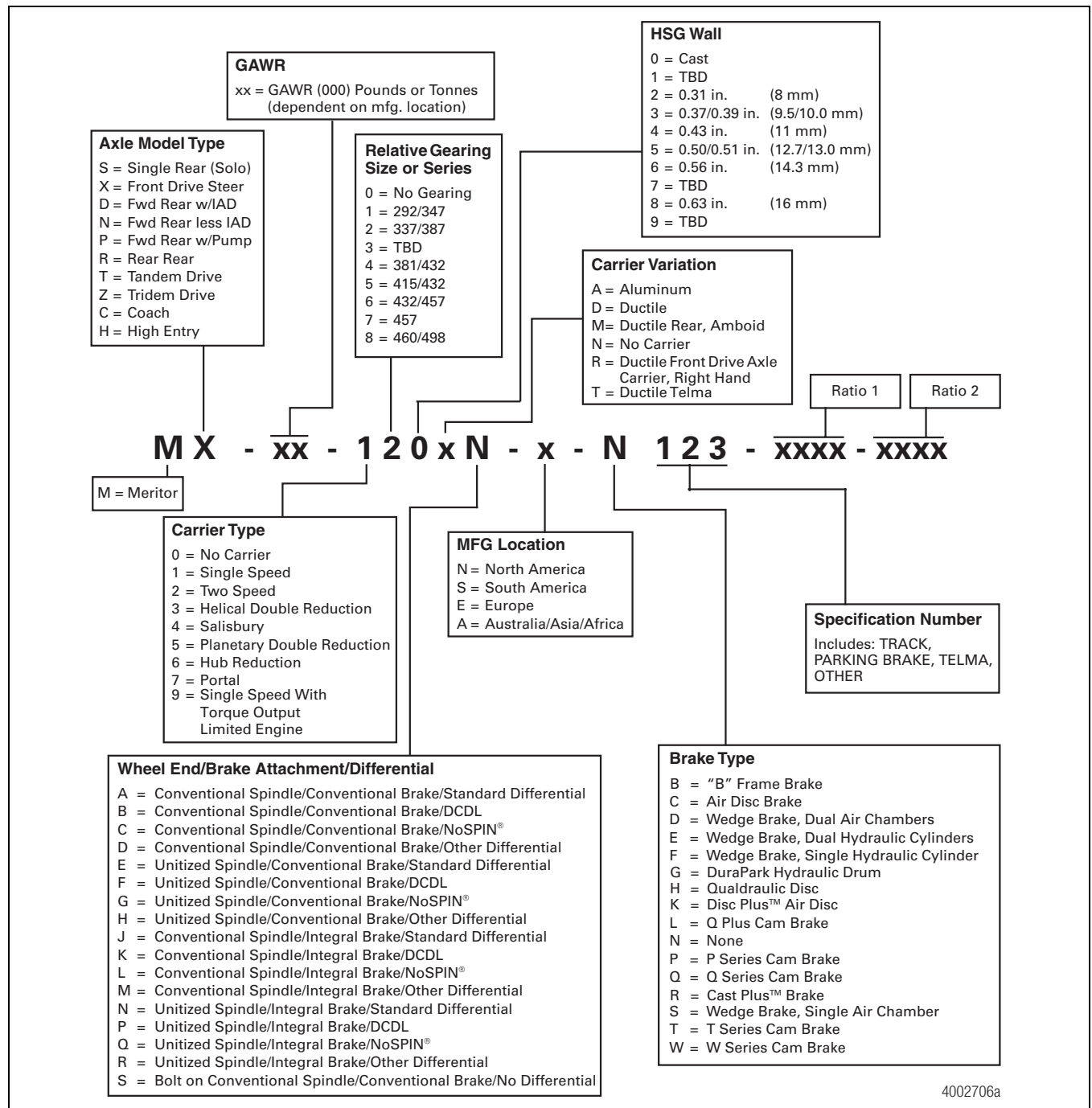

Front Axles

4 Front Axles

Front Drive Steer Axles

Current heavy-duty front drive steer axle models are identified by a letter and number system. The letters and numbers give important information about the specific axle model.

The first seven positions of the designations identify a basic axle model. The second group of letters and numbers identify particular specifications.

Model Nomenclature

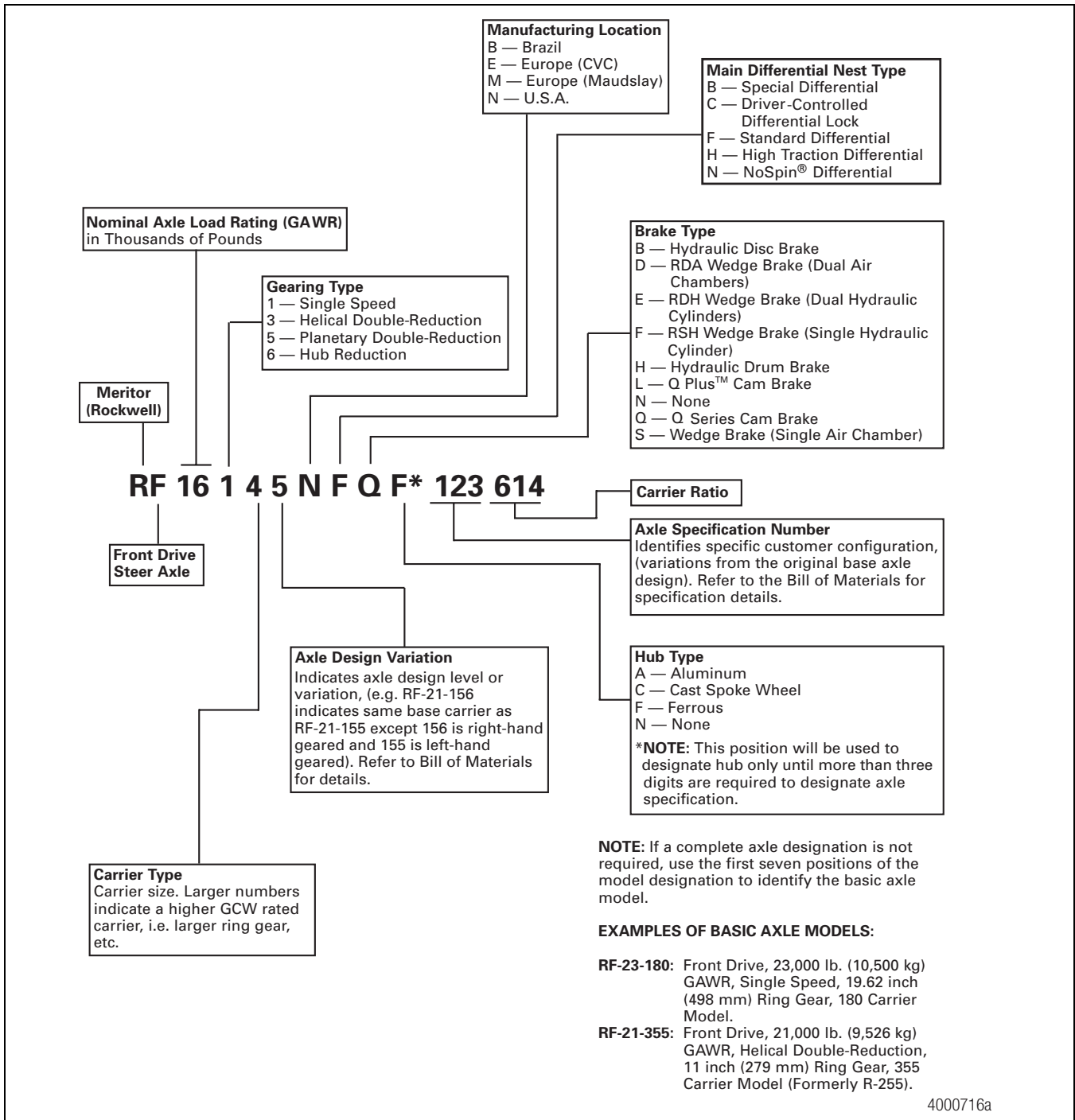

4000716a

Single, Tandem and Tridem Rear Drive Axles

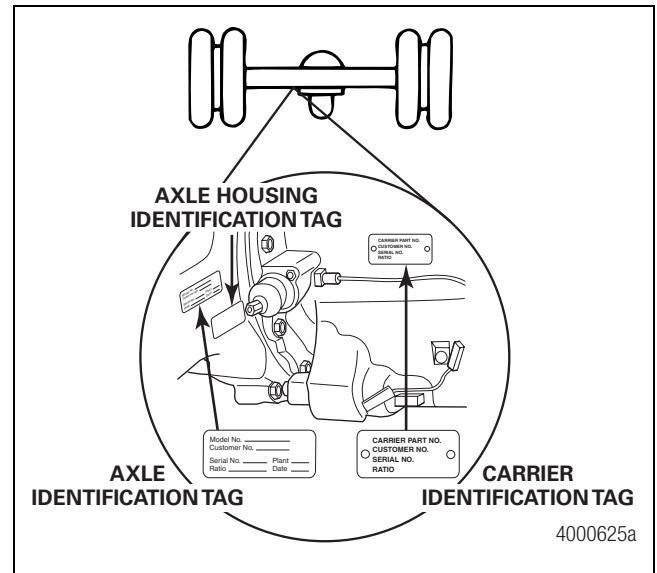
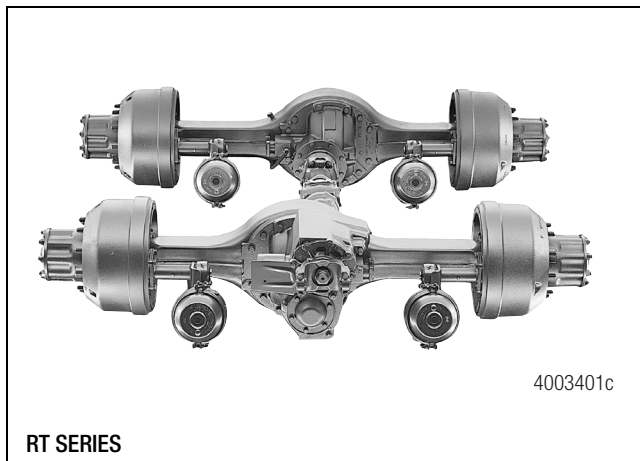

Rear Axles

Identification

An identification tag is riveted on the axle housing or on the differential carrier. Use the model number and the ratio number marked on the identification tag and the number on the carrier to order replacement parts

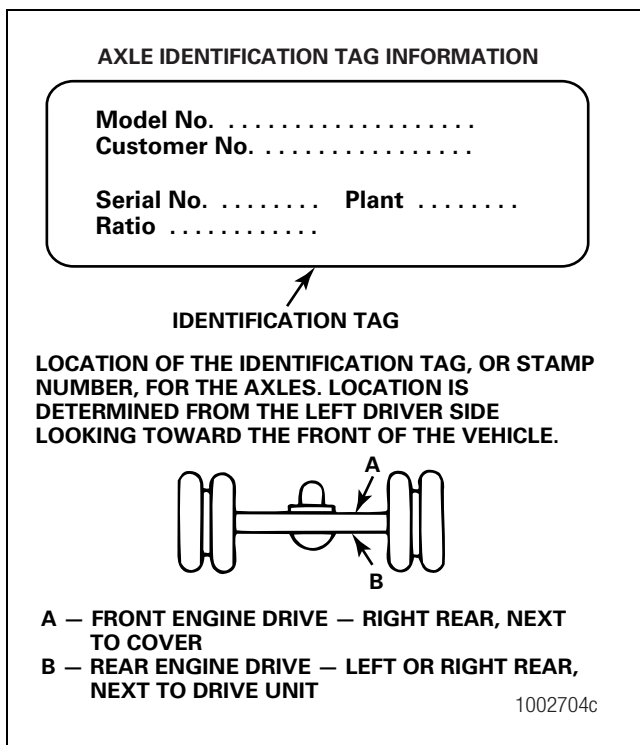

5 Rear Axles

Single, Tandem and Tridem Rear Drive Axles

Model Nomenclature

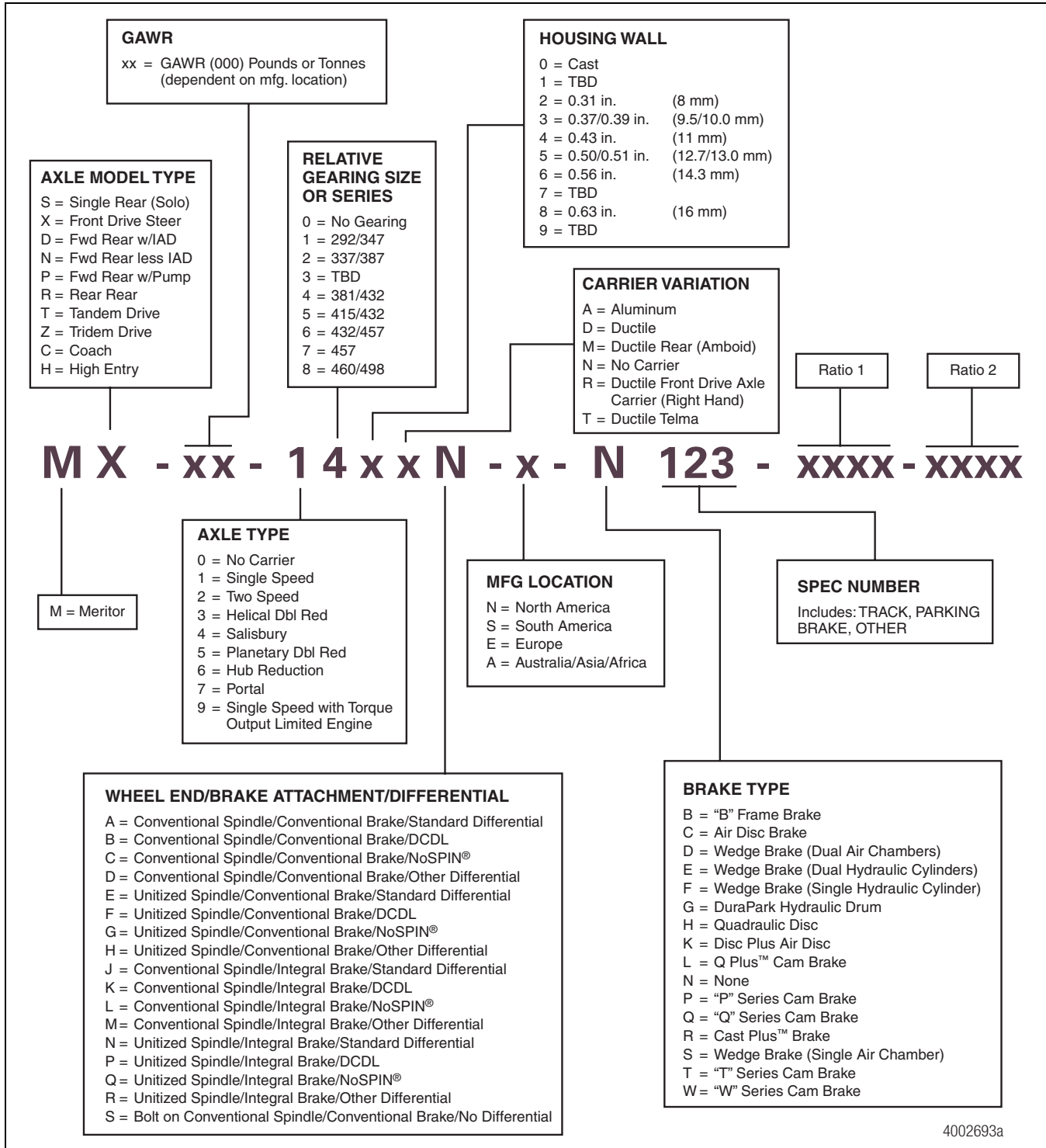

Single, Tandem and Tridem Rear Drive Axles

Model Nomenclature

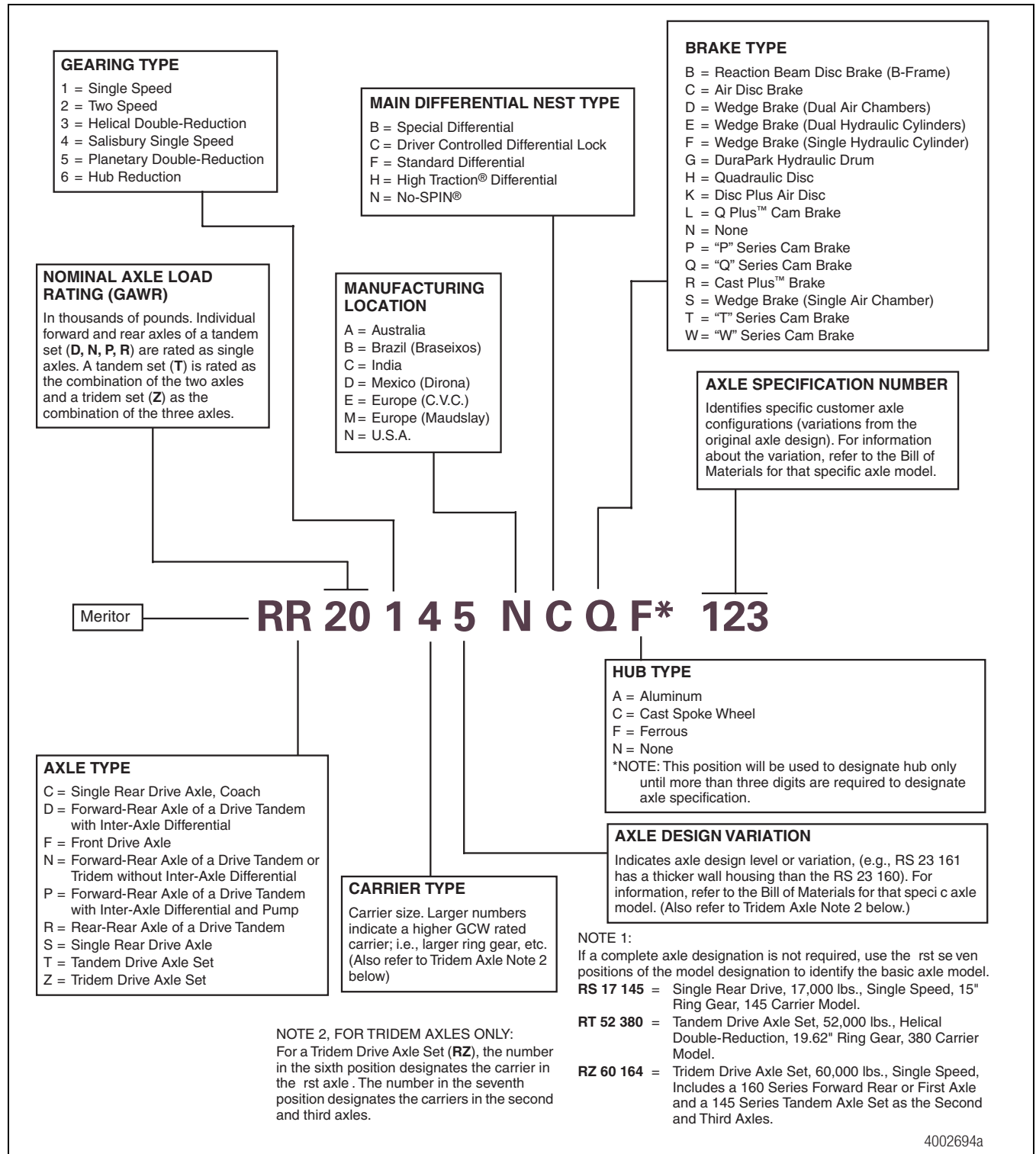

Rear Axles

6 Bus and Coach Axles

Bus and Coach Non-Drive Axles

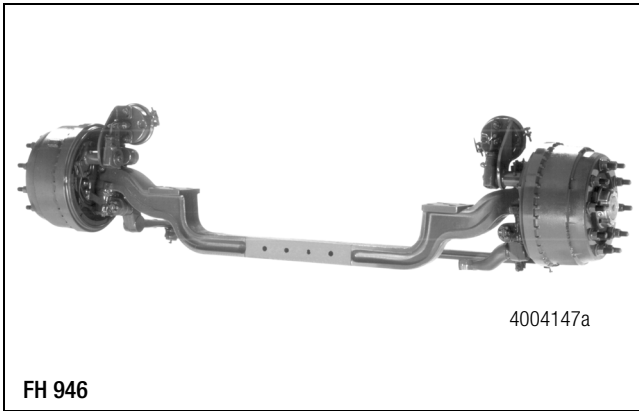

Identification

The front axle identification plate is located on the axle center.

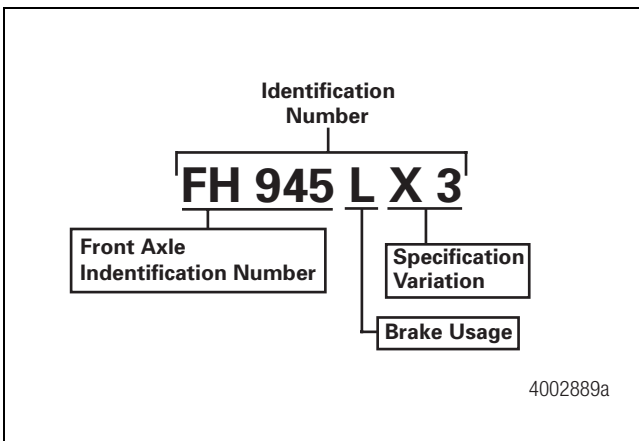
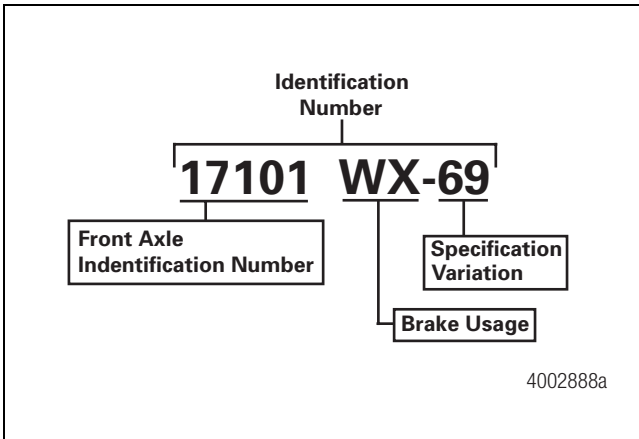

Bus and Coach Drive Axles

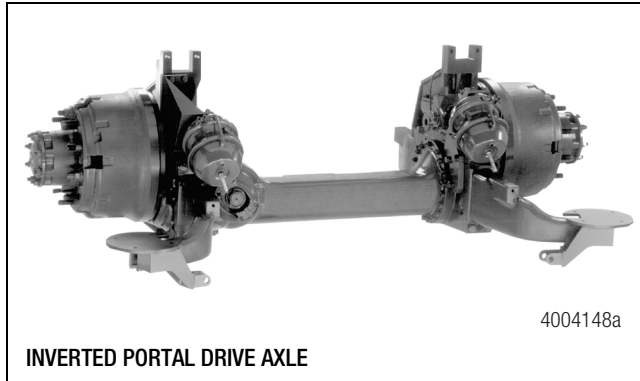

INVERTED PORTAL DRIVE AXLE

Identification

An identification tag is located on the axle housing or differential carrier.

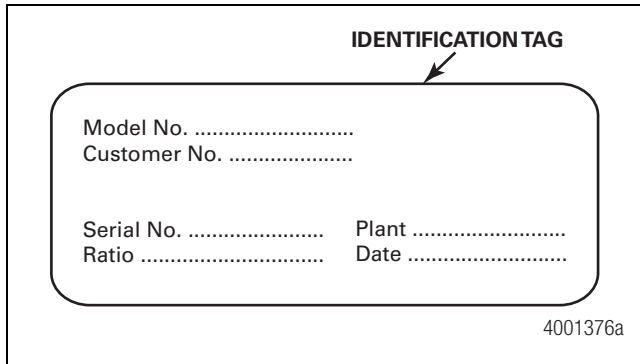

Model Nomenclature

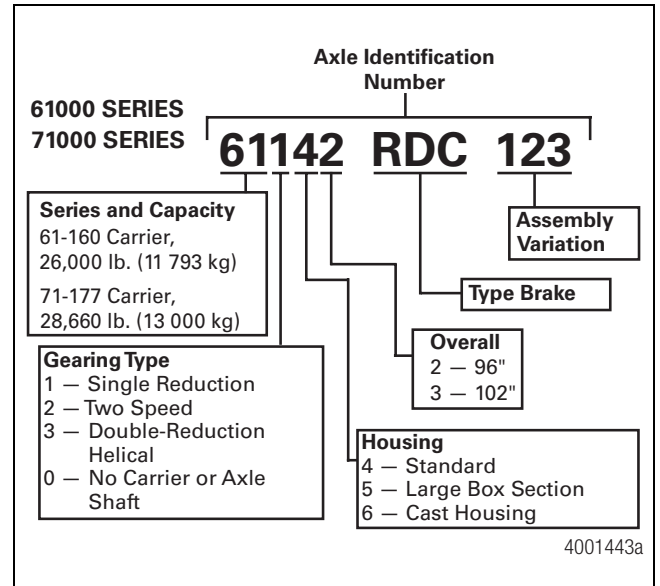
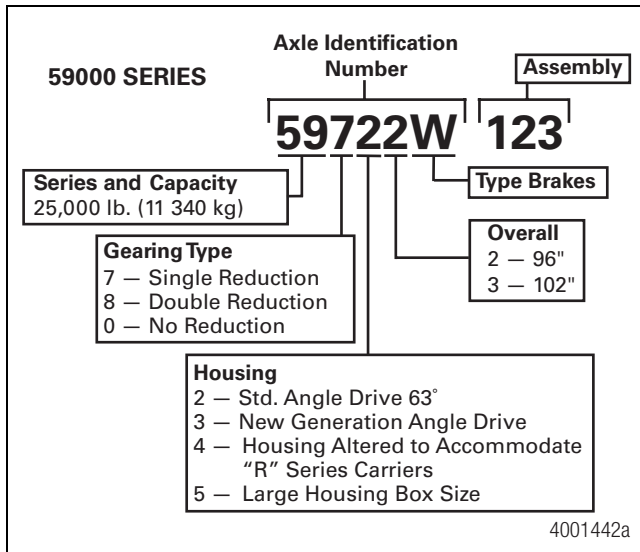

Bus and Coach Axles

6 Bus and Coach Axles

Bus and Coach Drive Axles

Model Nomenclature

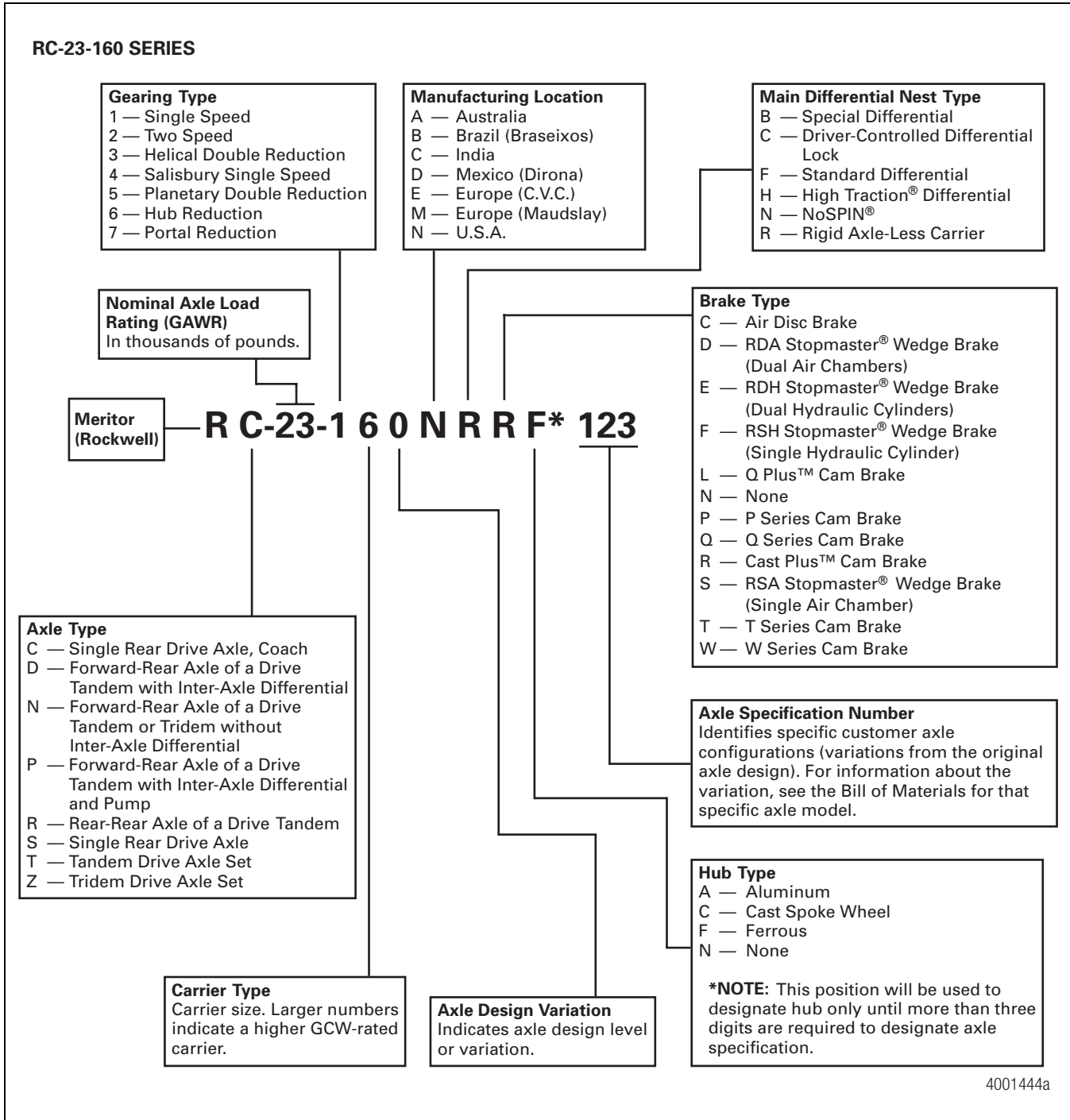

7 Trailer Air Suspension Systems

RideStar™ RHP

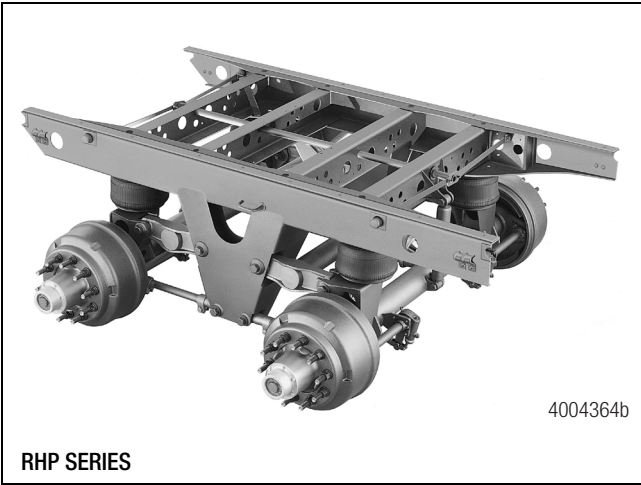

Model Nomenclature

The model number on the identification tag provides suspension and axle information.

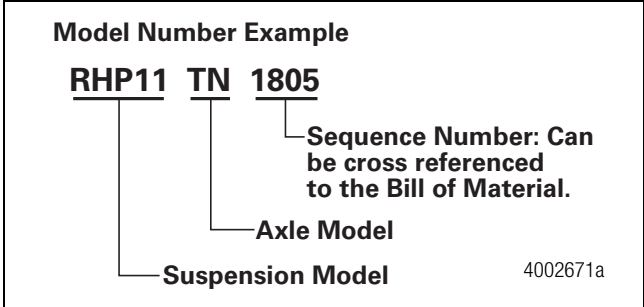

Identification

The identification tag is located on the roadside of the suspension near the pin release handle.

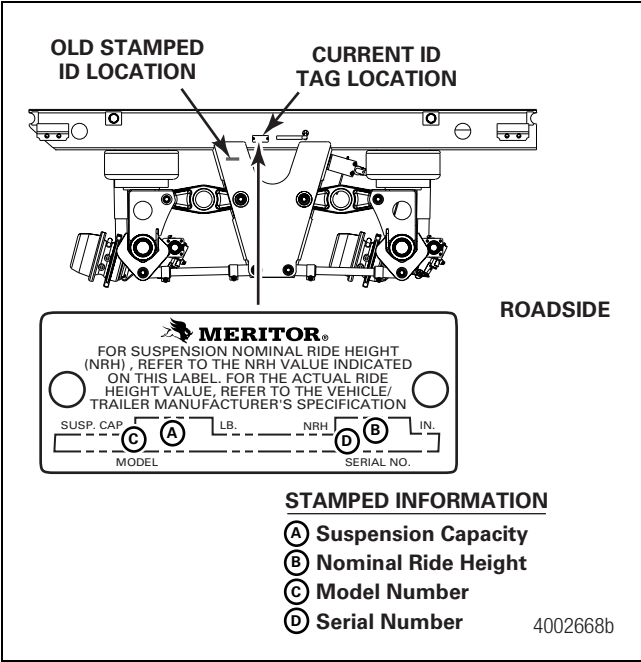

7 Trailer Air Suspension Systems

RideStar™ RFS Series

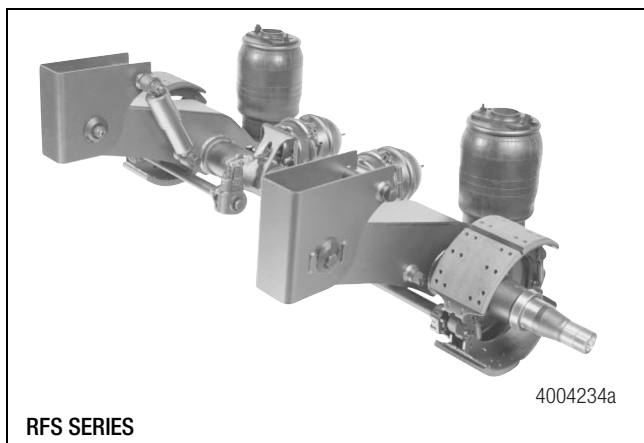

Identification

An identification tag is located on the rear of the roadside trailing arm.

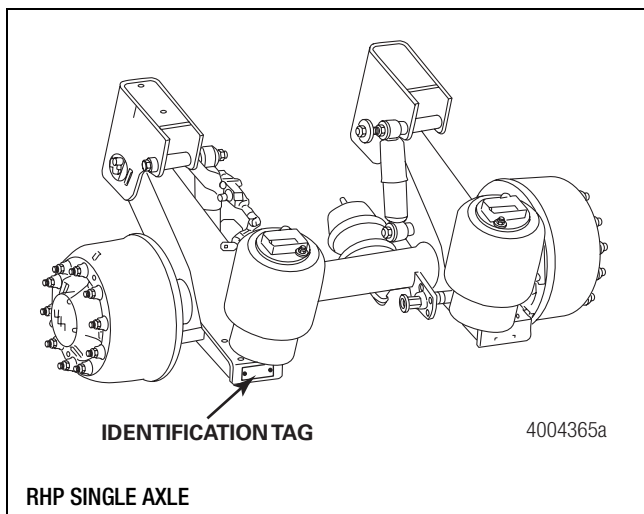

RideStar™ RFS Series

Model Nomenclature

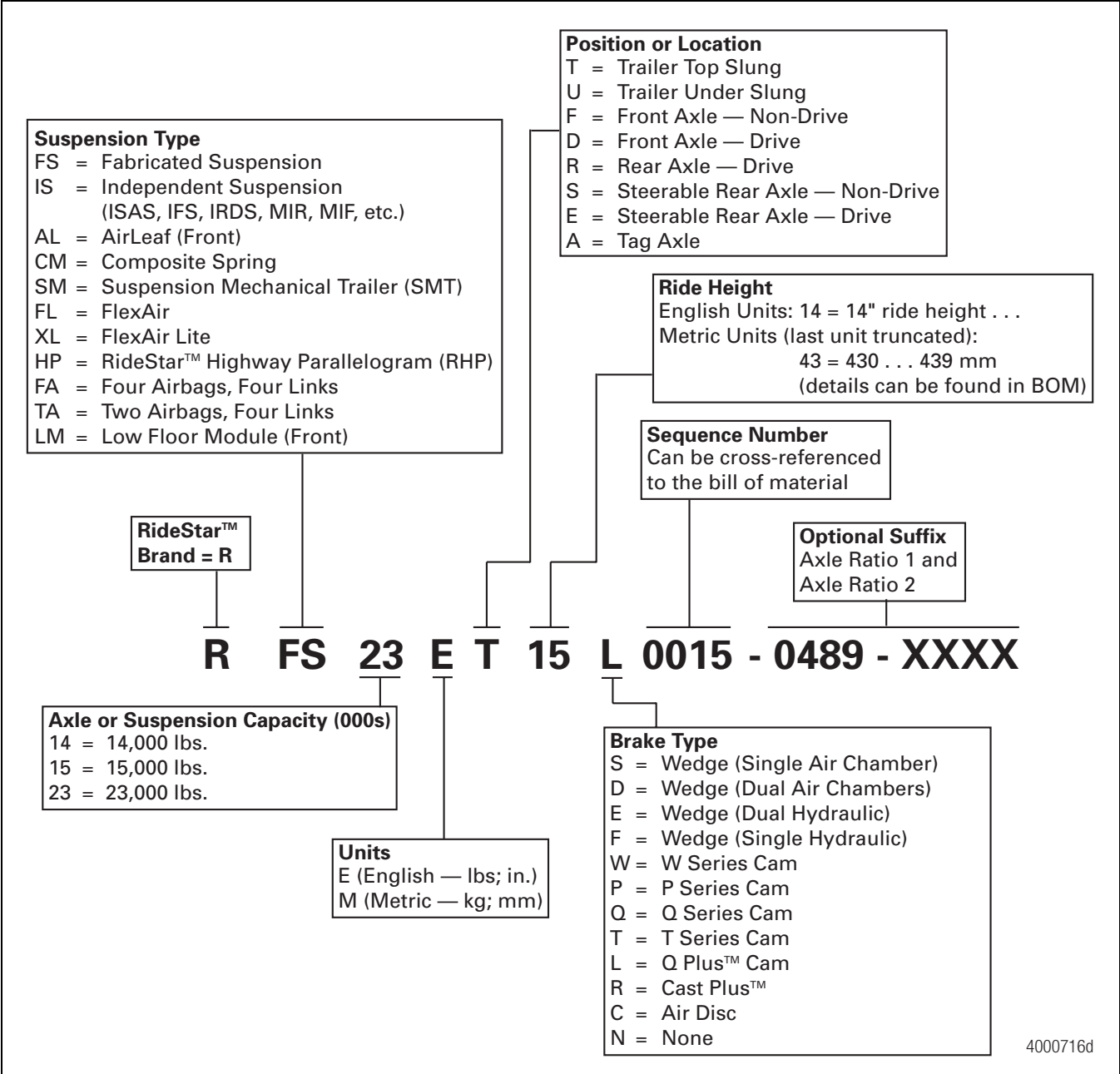

Trailer Air Suspension

8 Trailer Axles

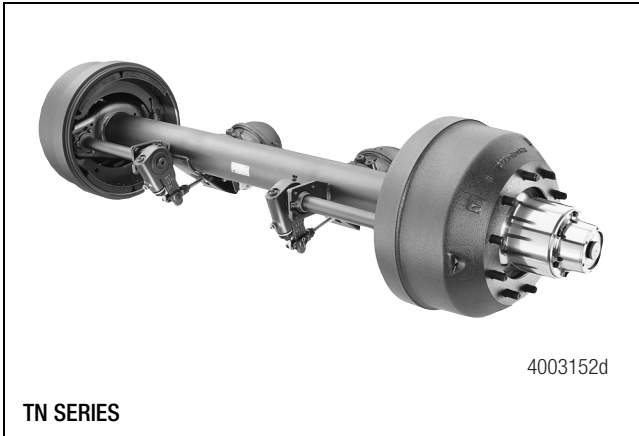

Identification

All of the information necessary to identify a particular trailer axle is indicated on the trailer axle identification tag. Located at the center of the axle beam, this ID tag is stamped with the axle model number, serial number and date of manufacture.

The model number is composed of letters and digits, for example, TN-4670-Q-2020. This number is used to identify the axle assembly when ordering replacement parts.

The serial number is composed of letters and digits, for example, KNA-38050685. This number can be used to identify a particular trailer axle, and the material and components used to build the axle.

The date of manufacture is indicated by a Julian date, for example, 27693. The first three digits (276) indicate the 276th day of the year, or October 3. The last two digits (93) indicate the year, or 1993.

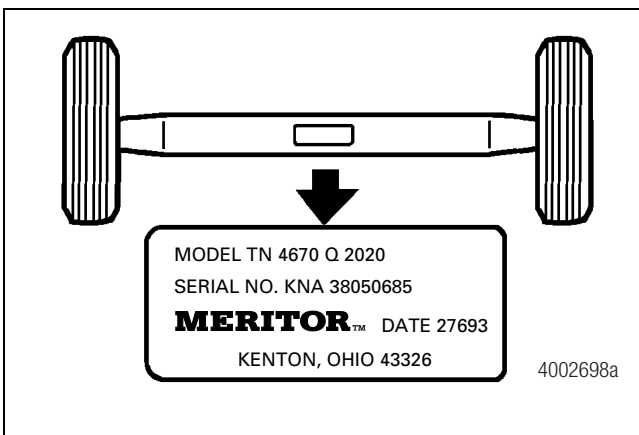

Model Nomenclature

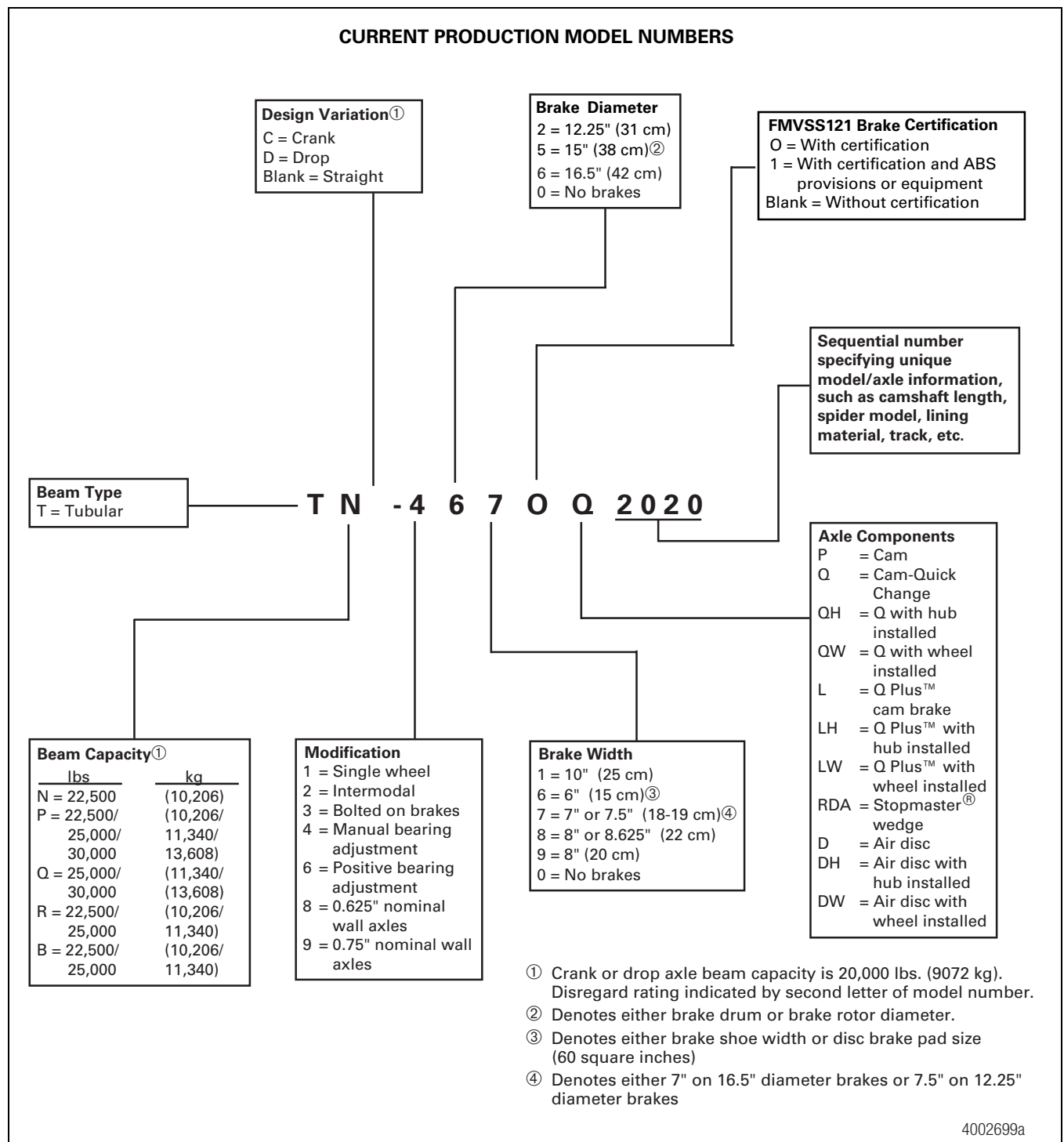

9 Transmissions

FreedomLine®

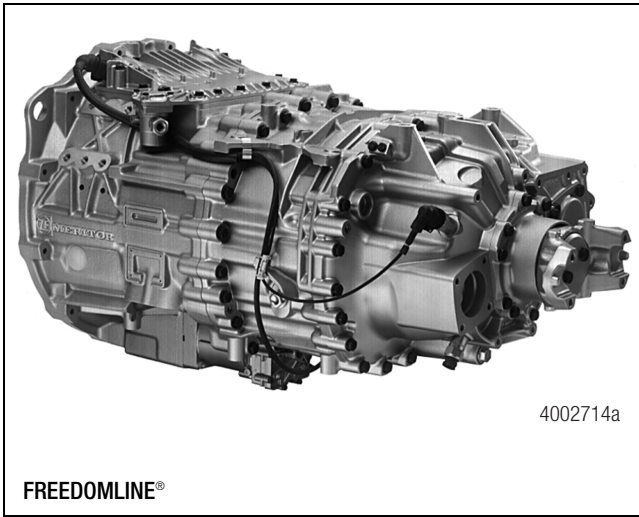

Identification

An identification plate is installed on the left side of the FreedomLine® transmissions.

Model Nomenclature

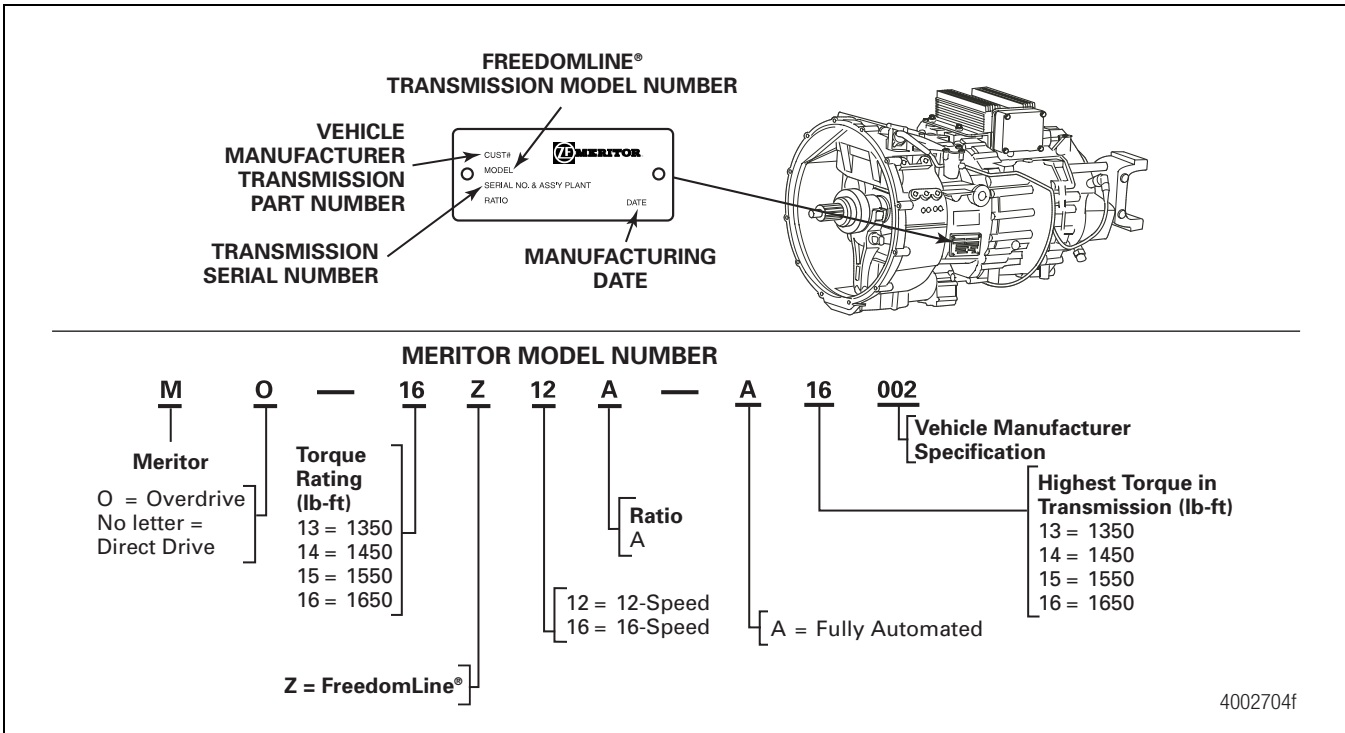

Platform "G"

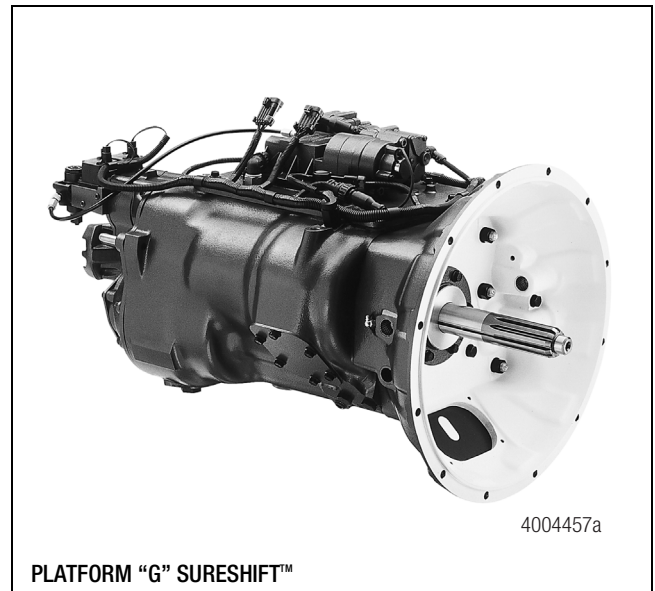
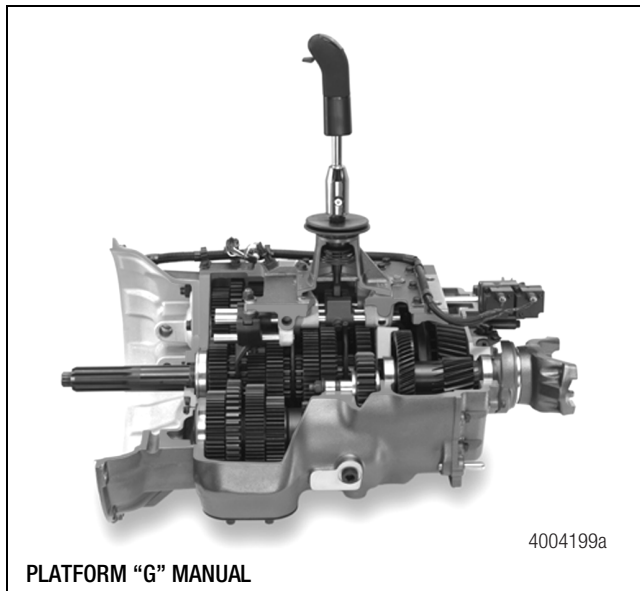

Identification

An identification plate is installed on the right side of the platform "G" transmissions.

Model Nomenclature

MERITOR TRANSMISSION MODEL NUMBER

These plugs indicate oil pump.

M

Meritor

O = Overdrive
No letter = Direct Drive

O

Torque Rating (lb-ft)

11 = 1150
12 = 1250
13 = 1350
14 = 1450
15 = 1550
16 = 1650

Design Platform

16

G

10

9 = 9-Speed
10 = 10-Speed

C

Ratio
A
B
C

M

M = Manual
S = SureShift™

18^①

002

Vehicle Manufacturer Specification

Highest Torque in Transmission (lb-ft)

11 = 1150	15 = 1550
12 = 1250	16 = 1650
13 = 1350	18 = 1850
14 = 1450	

① Progressive torque is an engine feature that requires a Torq-2 transmission. In models not featuring progressive torque, this number will be the same as the torque rating.

② Detroit Diesel Corporation

4002704g

Transmissions

10 Transfer Cases

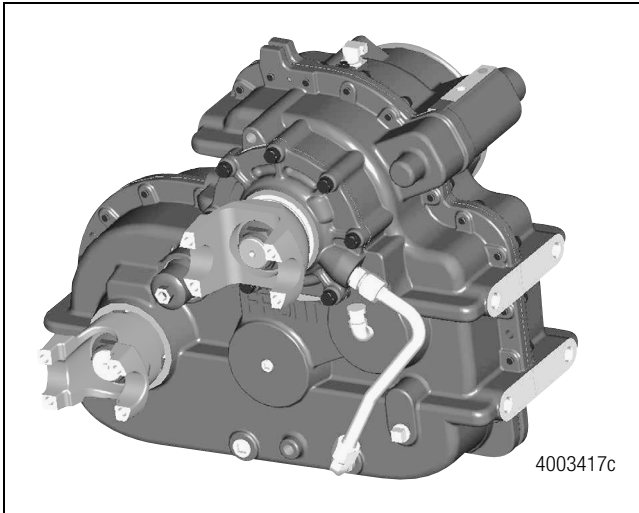

Identification

An identification tag is located on the front cover.

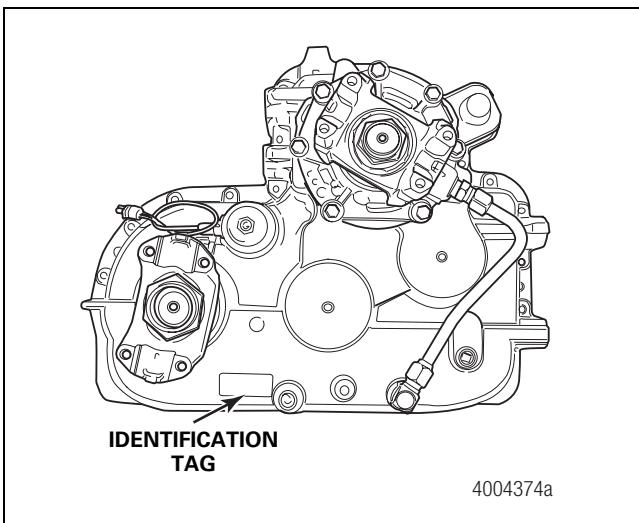

Model Nomenclature

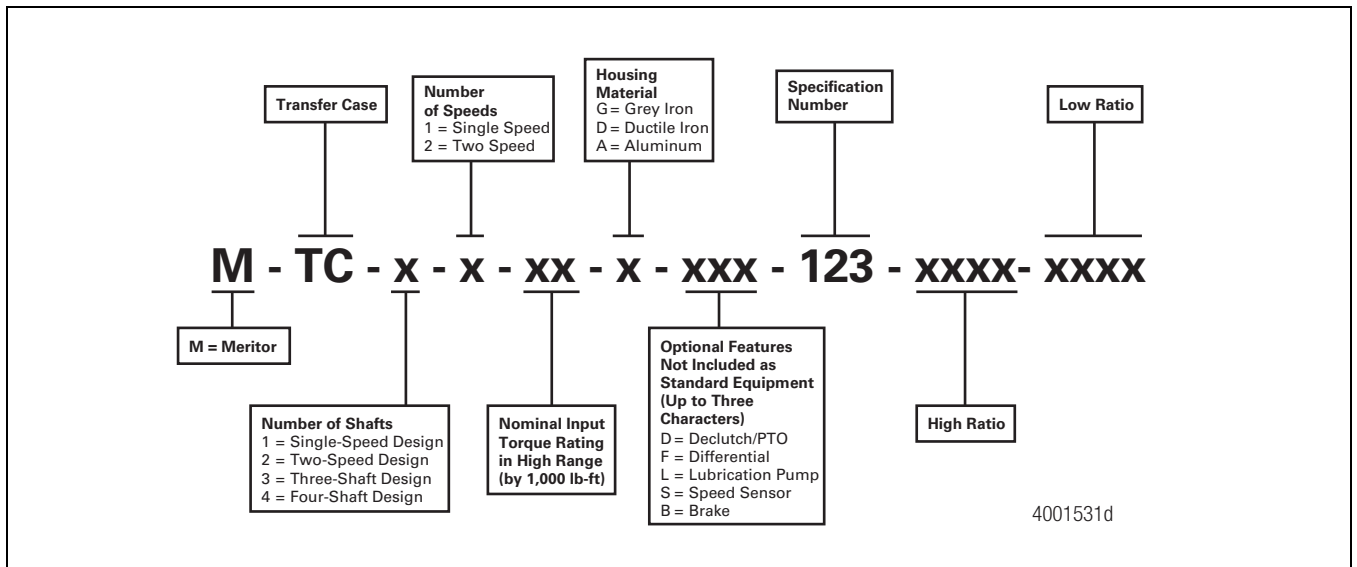
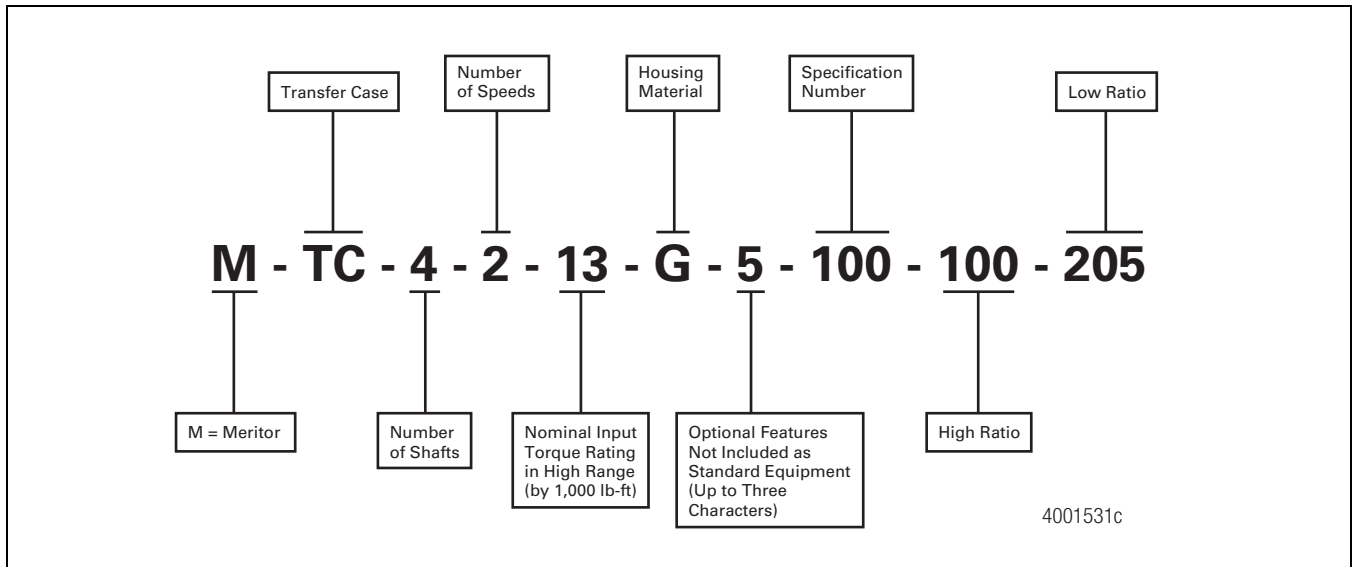

11 Meritor WABCO Components

NOTE: For a complete listing of all Meritor WABCO systems and components, including Roll Stability Control (RSC) for trucks and tractors and Roll Stability Support (RSS) for trailers, please visit the website at www.meritorwabco.com

Enhanced Easy-Stop™ Trailer ABS

The Meritor WABCO Easy-Stop™ Trailer ABS is an electronic, self-monitoring system that works with standard air brakes.

NOTE: S = Sensors
M = Modulator Valves

There is a specific ECU/valve assembly for each Easy-Stop™ Trailer ABS configuration.

- For 2S/1M Basic, the assembly consists of an ECU and a single modulator valve assembly.
- For 2S/2M Standard and 2S/2M, 4S/2M and 4S/3M Premium, the assembly consists of an ECU and a dual modulator valve assembly. The valve portion of the ECU/dual modulator valve assembly contains two separate modulator valves that share common control and exhaust ports. The 2S/2M Standard valve has only two sensor outlets and cannot be upgraded.

For Standard and Premium assemblies, the ECU and modulator valve may be individually replaced.

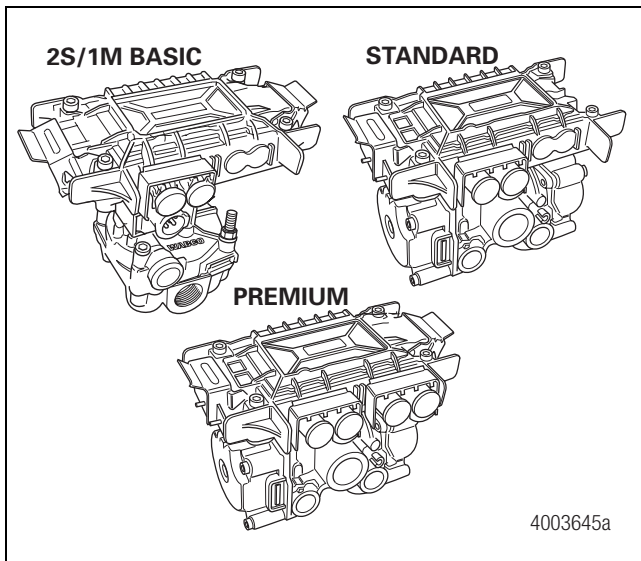

A 4S/3M configuration consists of an ECU/dual modulator valve assembly and one external ABS modulator valve.

Identification

To identify Enhanced Easy-Stop™, check the identification tag on the Electronic Control Unit (ECU). The part numbers for Enhanced Easy-Stop™ systems are shown below.

- 400 500 101 0 (2S/1M Basic for standard trailers)
- 400 500 104 0 (2S/1M Basic for dollies and steerables)
- 400 500 102 0 (2S/2M Standard)
- 400 500 103 0 (2S/2M, 4S/2M and 4S/3M Premium)

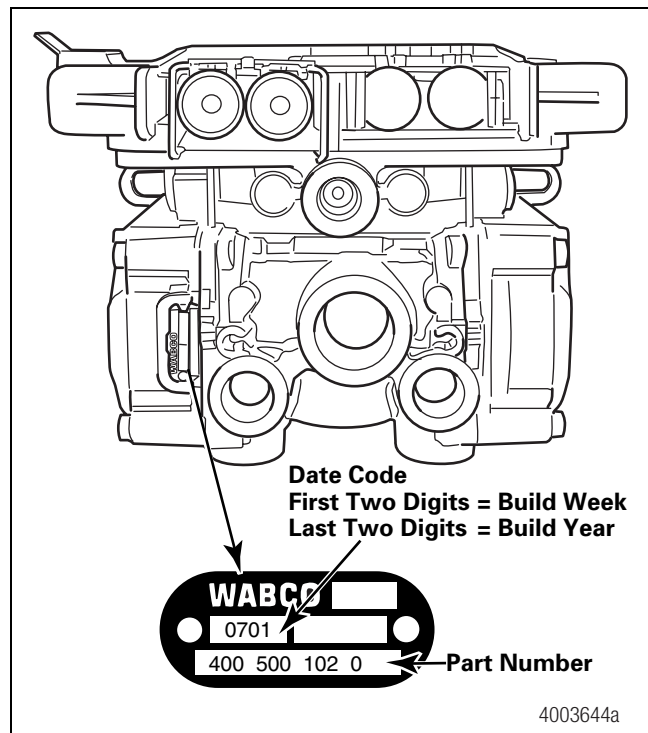

External Modulator Valve

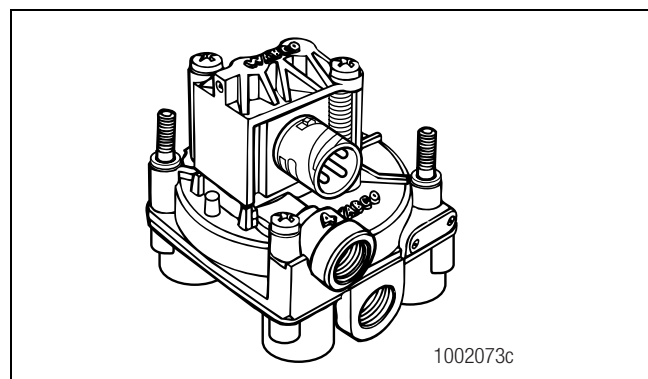

Sensor with Molded Socket

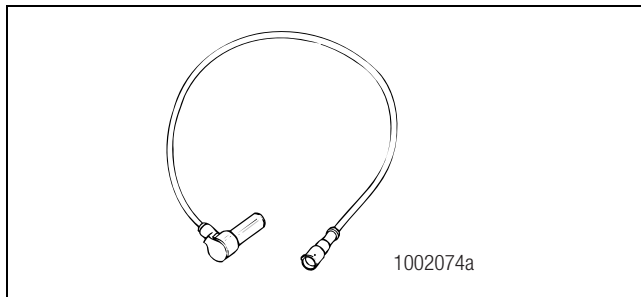

In-Line Filter Valve

Removes most contaminate particles from the trailer air brake system. Approved for use on all trailer applications for both control and supply lines.

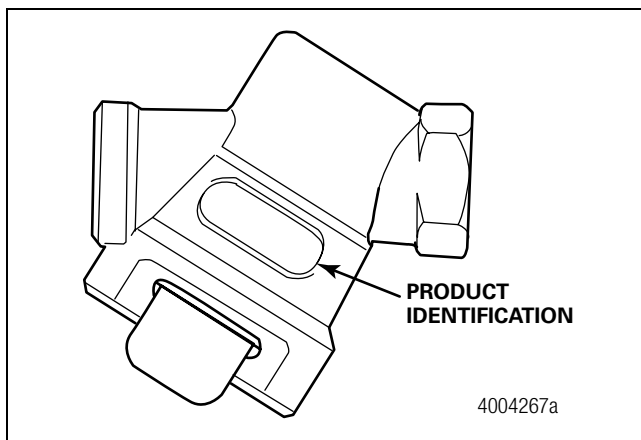

PLC DataMaster™ Trailer Data Extraction Module

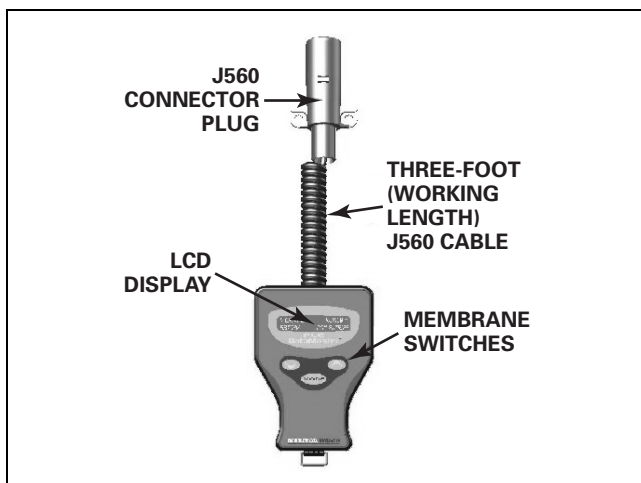

Reverse Detection Module

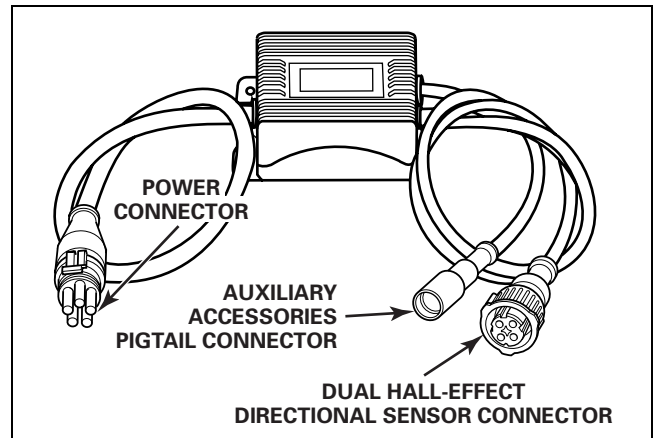

Hydraulic Anti-Lock Braking Systems (ABS)

Meritor WABCO Hydraulic ABS is an electronic wheel-speed monitoring and control system used on medium-duty trucks, buses and motor home chassis equipped with a hydraulic brake system.

There are two systems available, C and D version hydraulic ABS. D version ECUs are available in both cab- and frame-mounted versions.

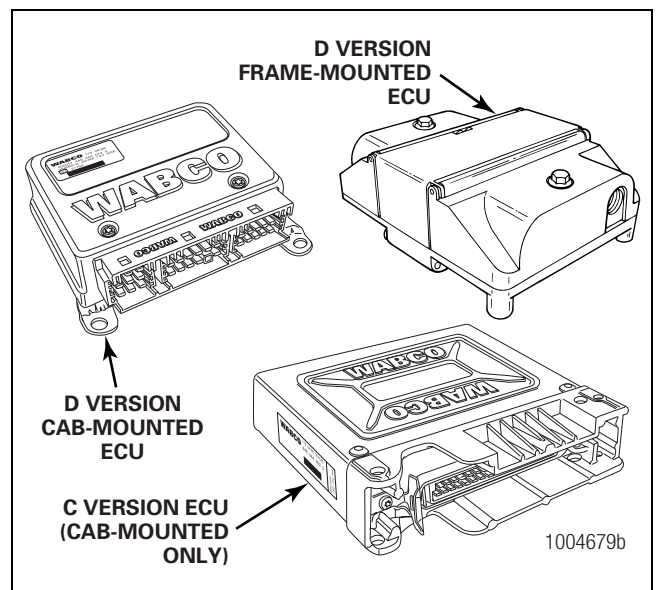

11 Meritor WABCO Components

Identification

The hydraulic ABS version installed on the vehicle may be determined by looking at the ECU. The C version system ECUs are larger than the D version ECUs. If the ECU is easily visible, look at the part number identification tag. The D version ECUs will have a D designation printed on the tag. There is no letter designation on C version ECUs.

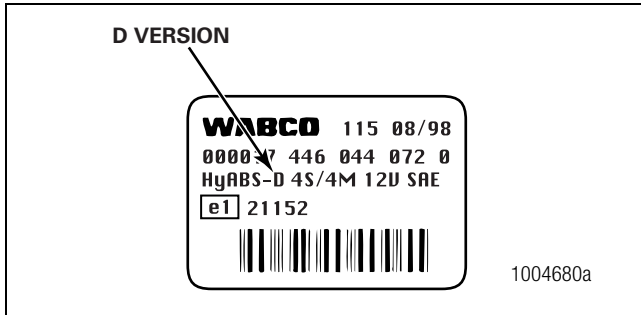

Modulator Assembly

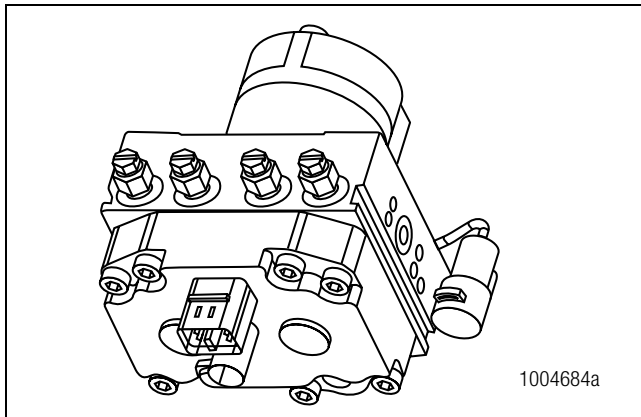

Sensor with Molded Socket

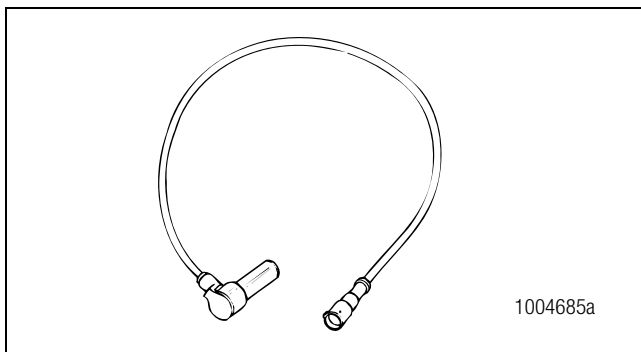

Pneumatic ABS for Trucks, Tractors and Buses

Meritor WABCO pneumatic ABS is an electronic system that monitors and controls wheel speed during braking for trucks, tractors and buses. The system works with standard air brake systems. Pneumatic ABS ECUs are available for cab- or frame-mounted applications. Basic and universal ECUs are cab-mounted.

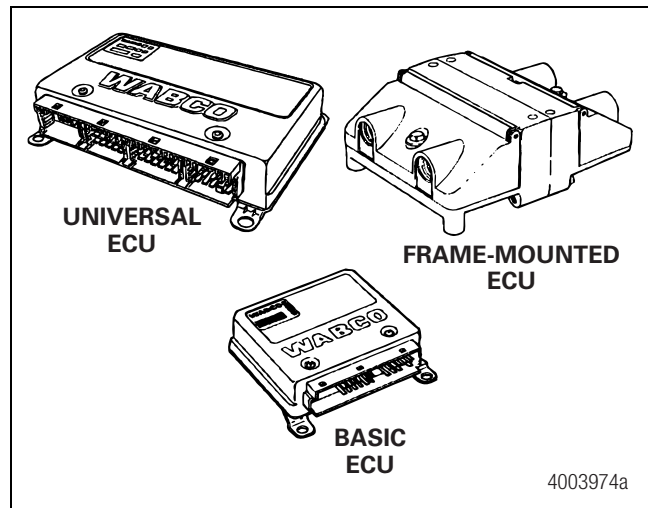

Identification

The ABS version is marked on the ECU.

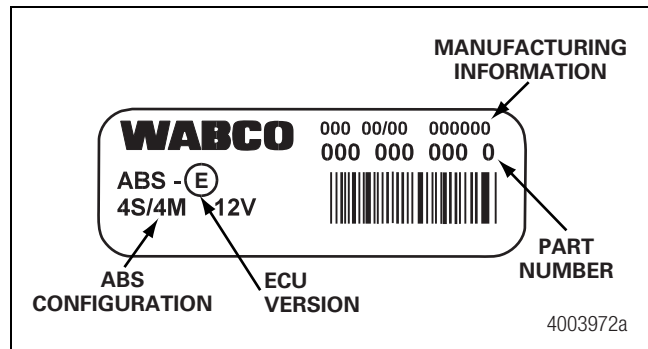

ABS Valve Package — Rear Axle

The valve package provides an alternative to separate valve installation by combining a service brake relay valve with two ABS modulator valves.

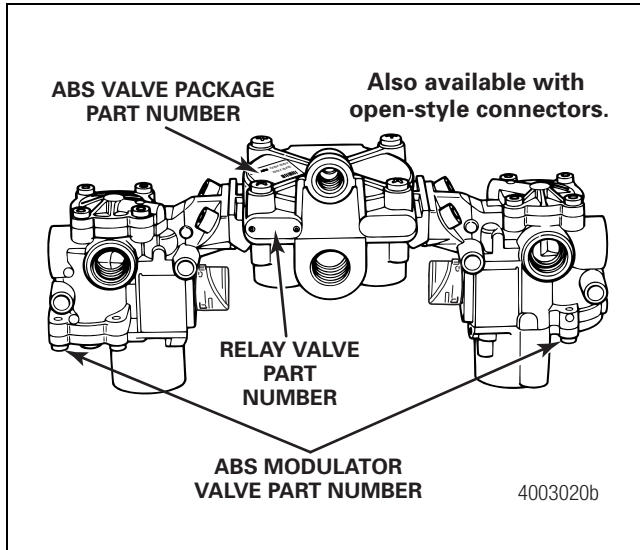

ABS Valve Package — Front Axle

The valve package provides an alternative to separate valve installation by combining a quick release valve with two ABS modulator valves.

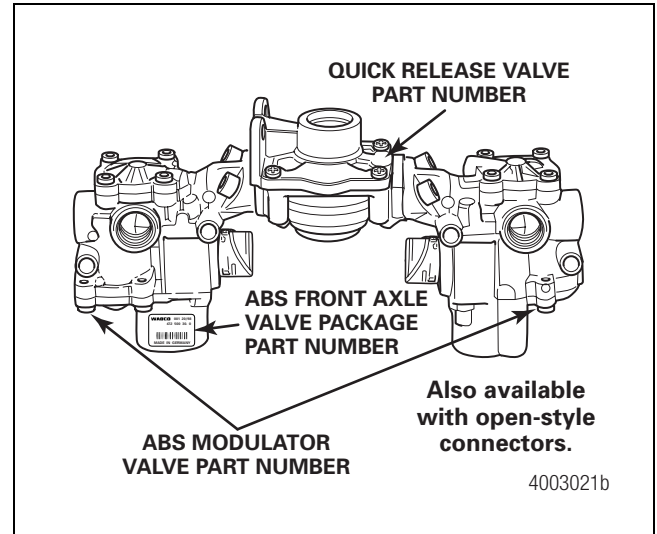

ABS/ATC Valve Package — Rear Axle

The valve package provides an alternative to separate valve installation by combining a service brake relay valve with two ABS modulator valves and one ATC valve.

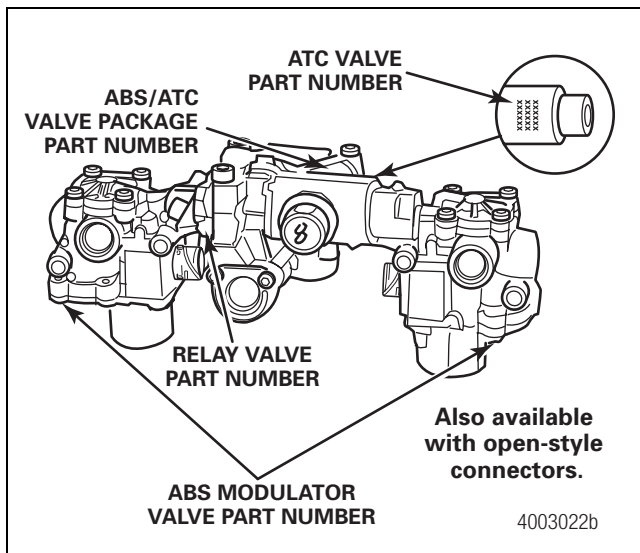

ABS Modulator Valve

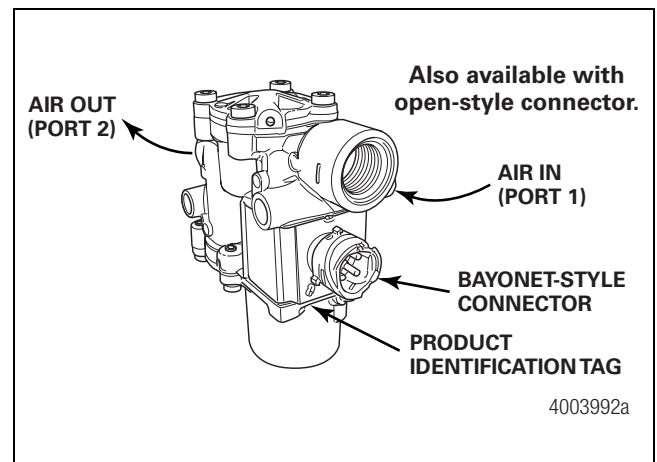

11 Meritor WABCO Components

Automatic Traction Control Valve

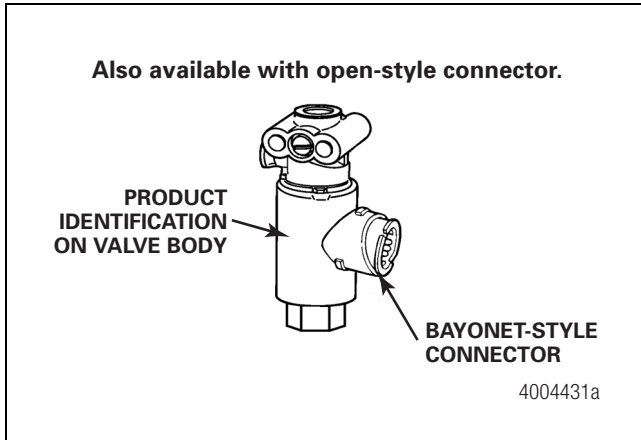

Straight Sensor

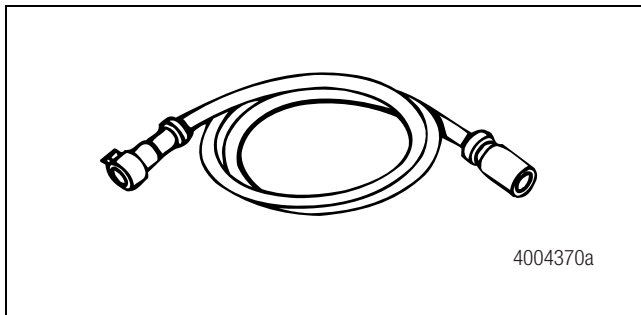

Right Angle (90°) Sensor

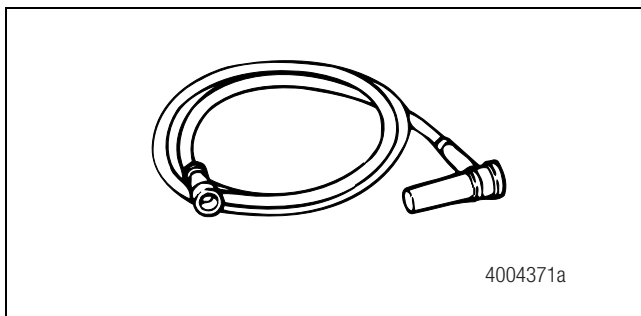

Air Dryers

Identification

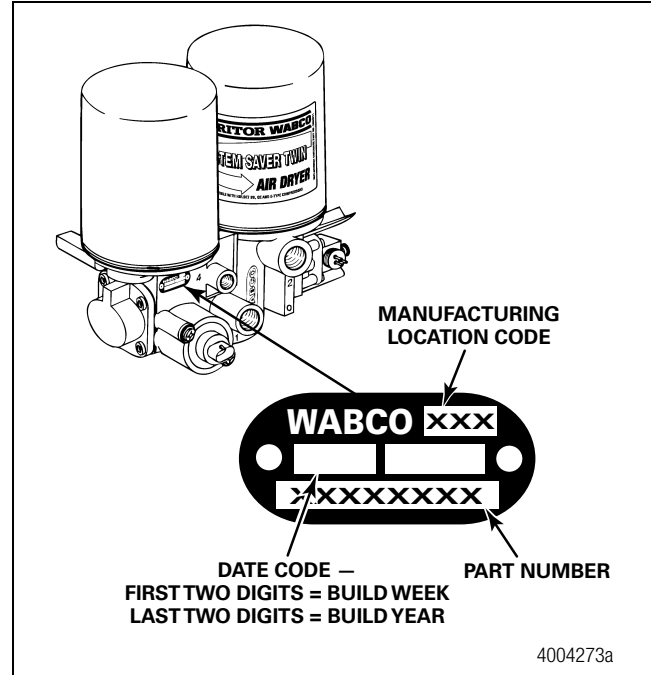

Alphabetical designations of the System Saver Series family of air dryers have specific meanings.

- P indicates an external purge tank is used for desiccant regeneration
- U indicates discharge line — unloaded compressor
- E indicates a Holset-style compressor function
- G indicates integral governor for air compressor control
- UP indicates discharge line — unloaded compressor (with external purge tank)

System Saver 1200/1800: System regeneration valve assembly on side of dryer

System Saver 1200E: Tubing and banjo fitting at front of dryer

System Saver 1200P/1800P: Uses dedicated purge tank. Port 22 drilled and tapped

System Saver 1200U/1800U: Small regeneration hole visible in back of Port 1 when fitting is removed. No spring in turbo cut-off valve assembly

System Saver 1200UP/1800UP: Port 22 drilled and tapped. Small regeneration hole is visible at back of Port 1 when fitting is removed. No spring in turbo cut-off valve assembly. Dedicated purge tank

The air dryer base is the same for both the 1200 and 1800 Series air dryers; however, the 1800 Series canister is 3.2-inches taller than the 1200. This larger canister contains 50% more desiccant, which makes the 1800 ideal for applications calling for frequent starts, stops and long compressor cycles.

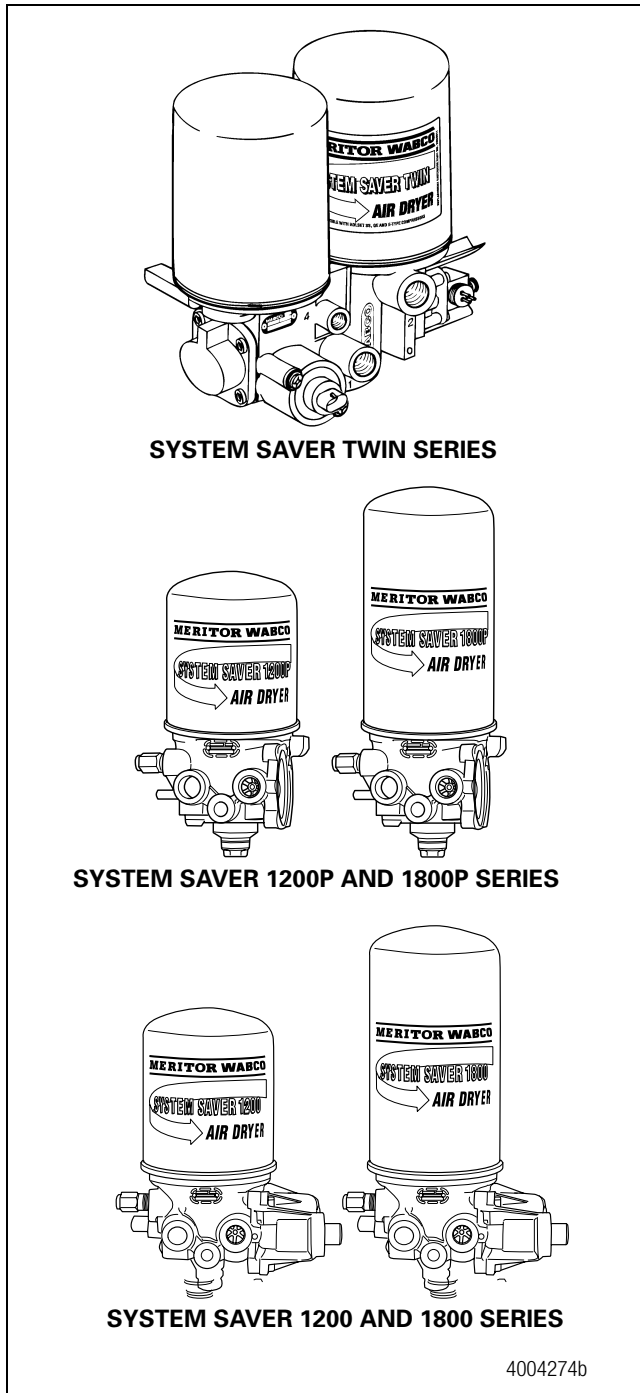

Air Compressors

The Meritor WABCO System Saver 318 air compressor provides and maintains air under pressure to operate devices in the air brake and auxiliary air systems of a vehicle. It consists of two major subassemblies: Cylinder head and crankcase/cylinder block. The System Saver 318 air compressor is used on Mack engines and is available in non-through drive and through drive versions. The through drive version is required to run hydraulic power steering pumps.

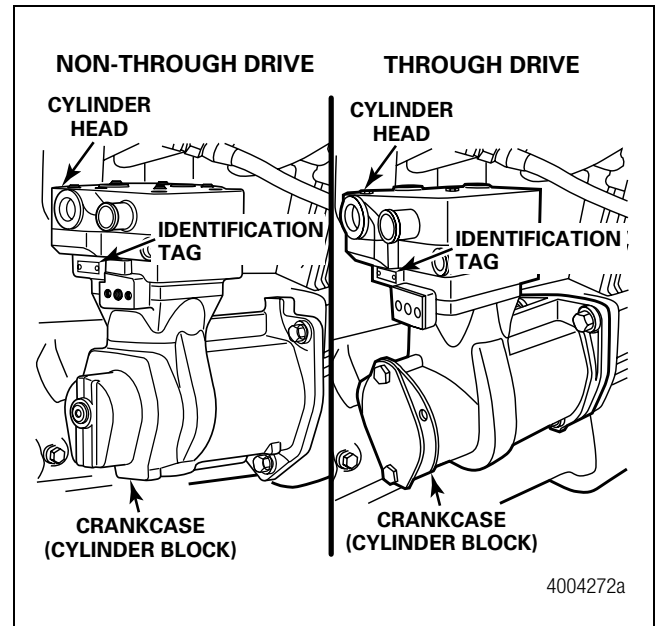

11 Meritor WABCO Components

Air Brake System Valves

Meritor WABCO provides a complete line of air brake valves. Please visit the website at www.meritorwabco.com for complete information.

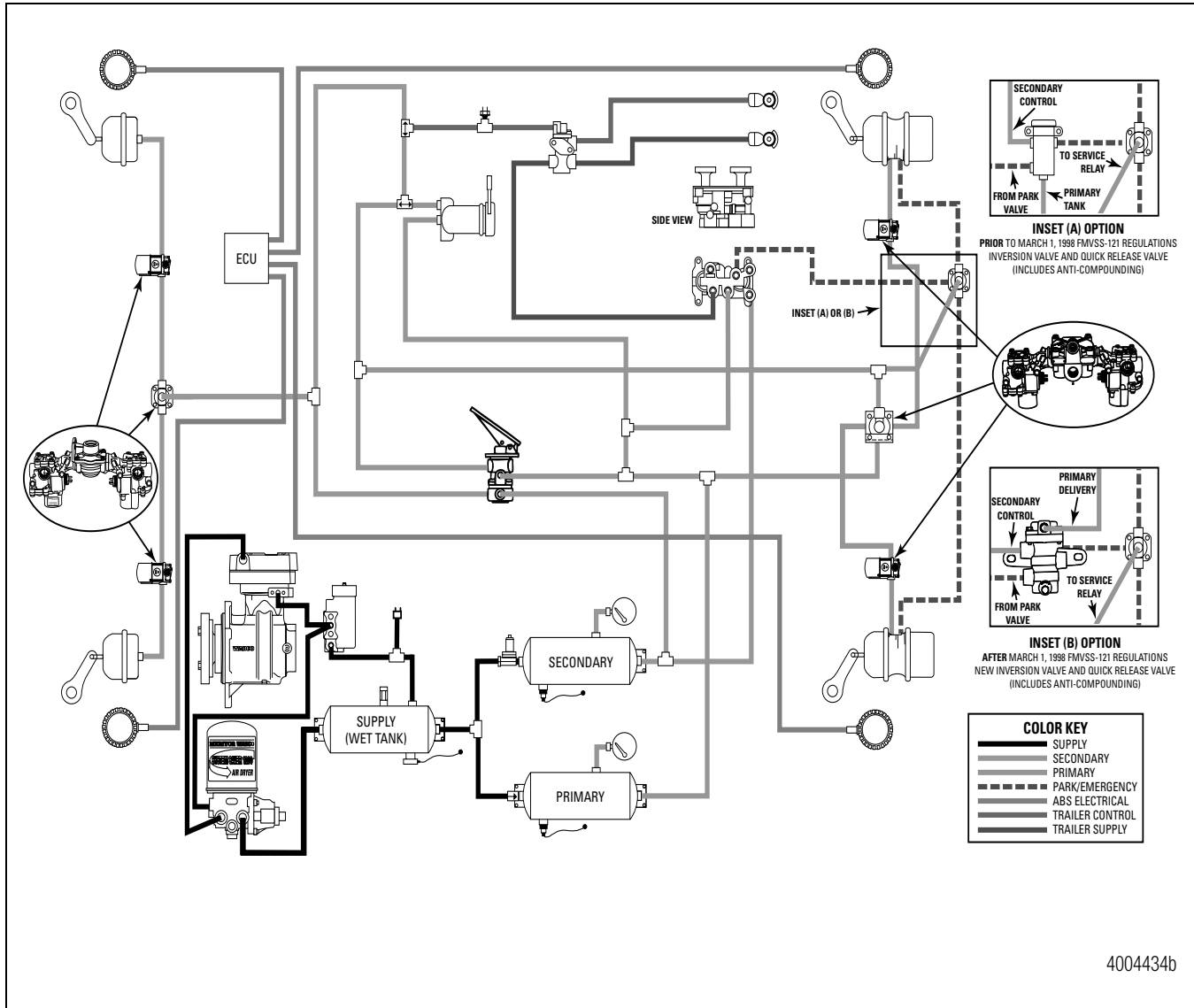

4004434b

Single or Dual Circuit Foot Valve and Pedal

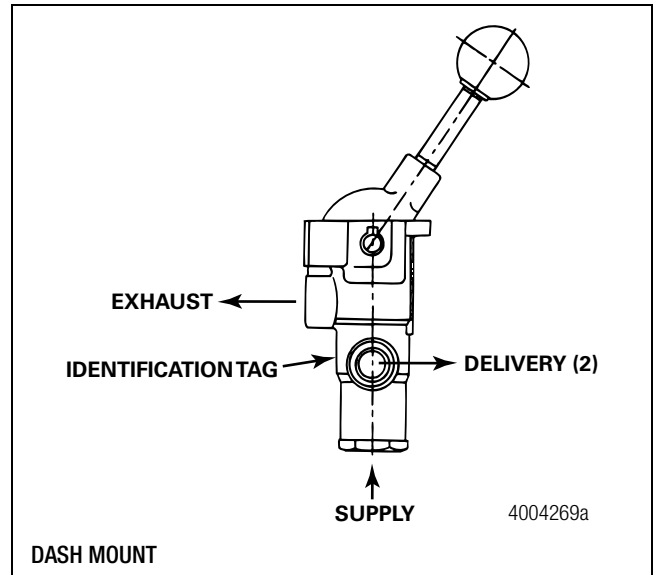
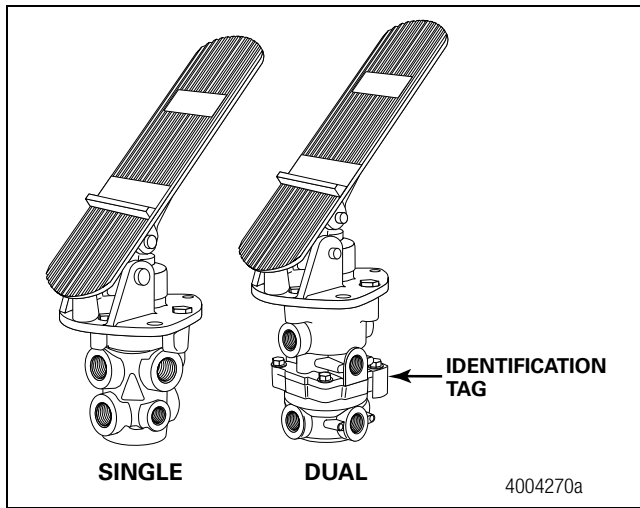

Hand-Operated Valves

Trailer Brake Control Valves

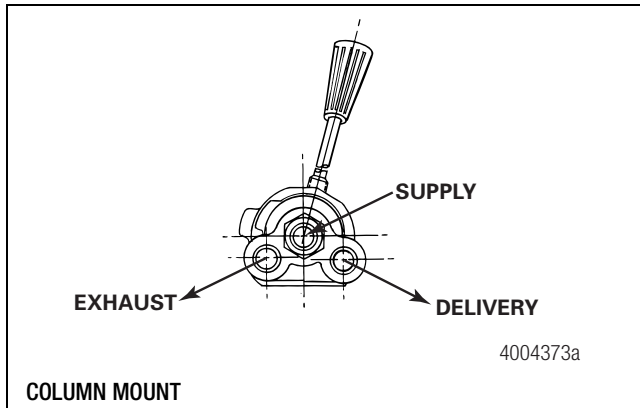

Park Brake Valve

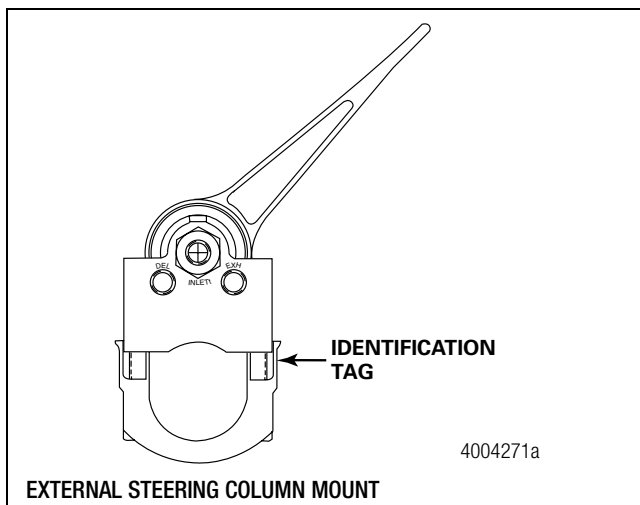
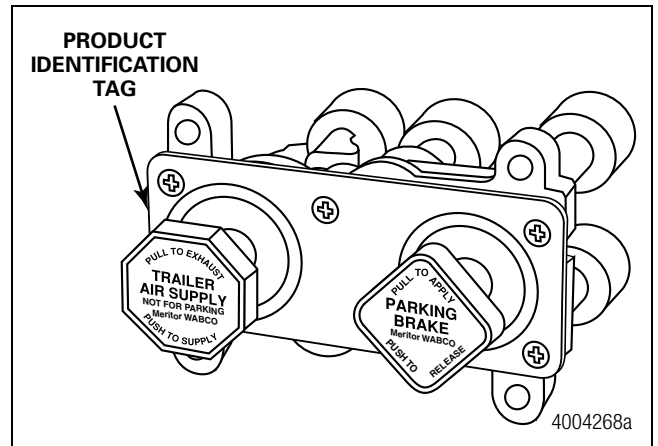

IR2 Valve

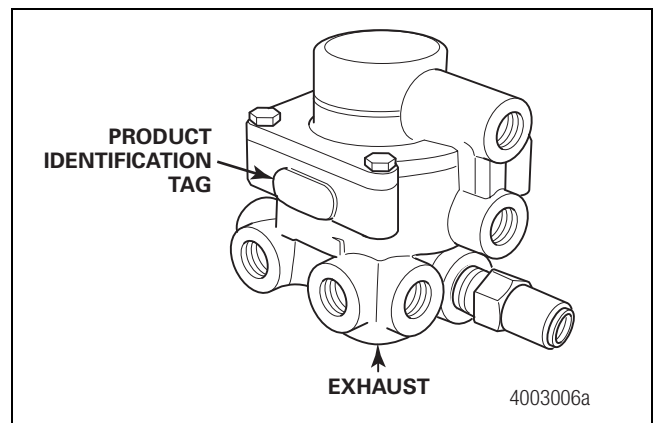

Meritor
WABCO

11 Meritor WABCO Components

Leveling Valves

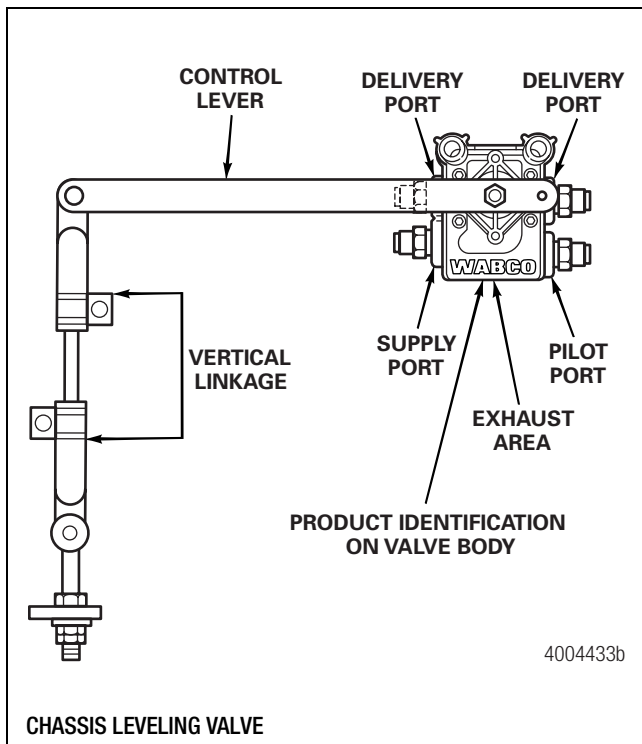
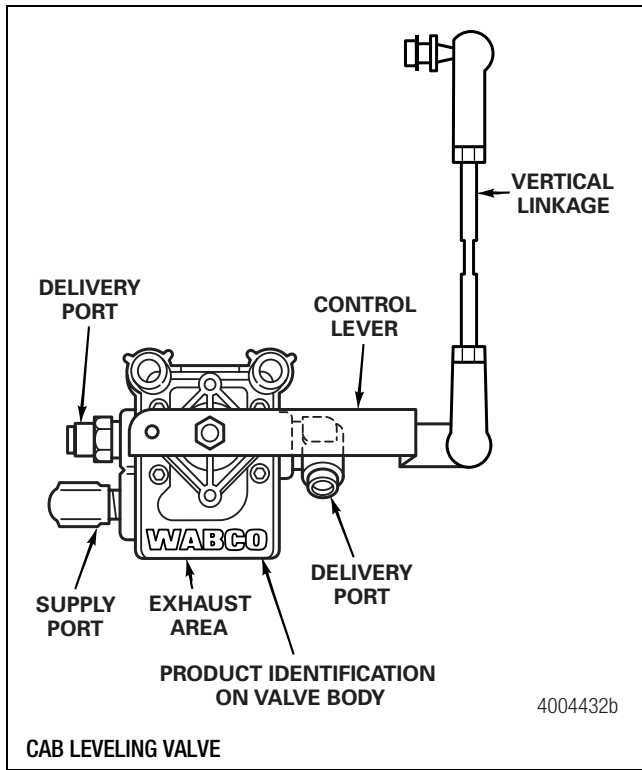

Identification

Shock absorbers are identified by the following.

- The Gabriel logo, older products do not have the Gabriel stamp
- The country of origin, either Canada or South Africa
- A date code

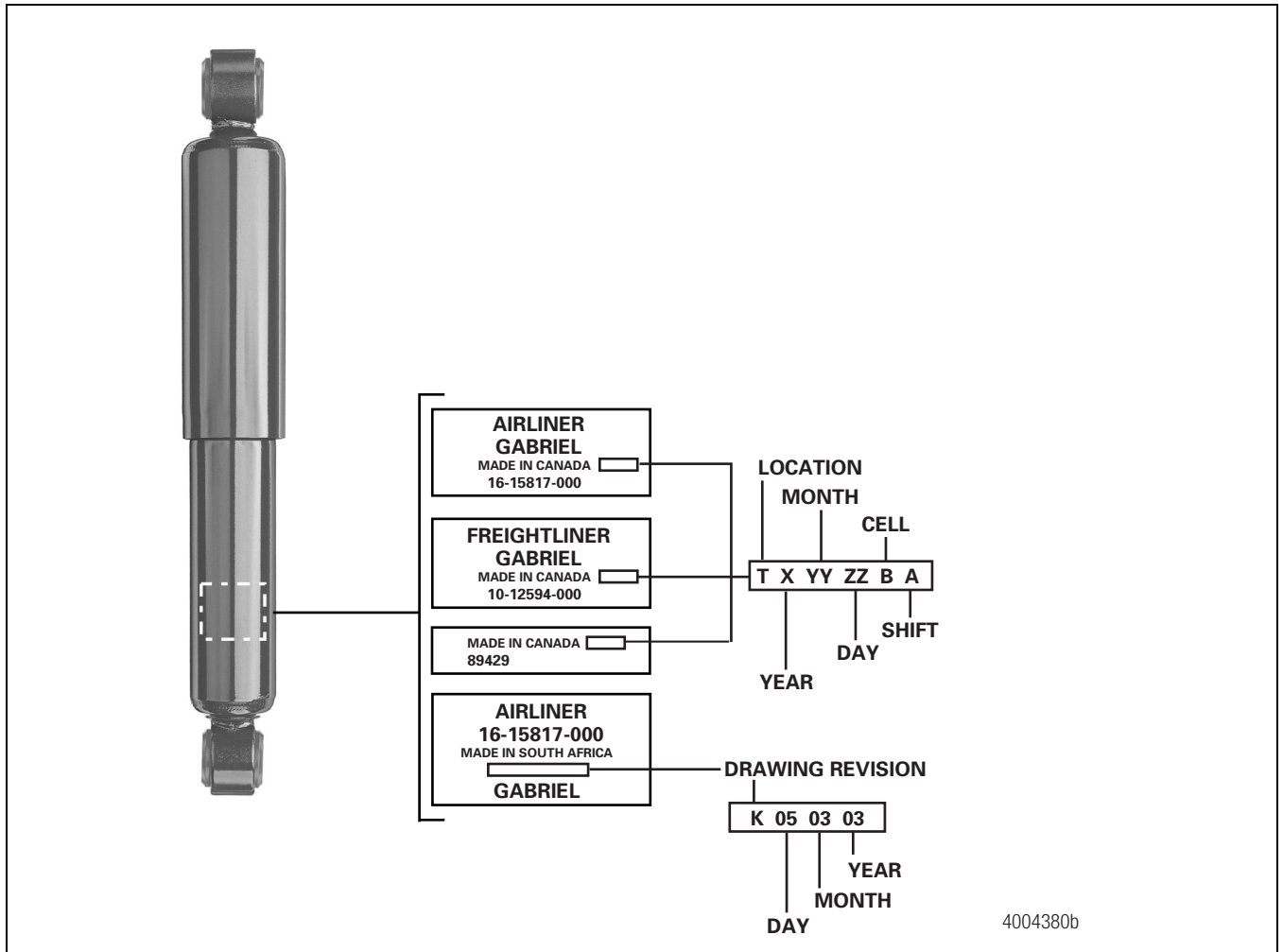



Meritor Heavy Vehicle Systems, LLC
2135 West Maple Road
Troy, MI 48084 USA
800-535-5560
www.drivetrainplus.com

Copyright 2004
ArvinMeritor, Inc.

Printed in USA

Issued 03-04
TP-03167 (16579/24240)

ArvinMeritor™